

Coolant Valve

Series SGC

For 0.5 MPa/1.0 MPa/1.6 MPa

● **Flow rate**
Av factor (in case of 0.5 MPa specification)

SGC2:	155
SGC3:	284
SGC4:	440

- **Service life: 5 million cycles or more**
(based on SMC's test condition)
- With auto switches for verifying whether the valve is open/closed
- Reduction of environmentally harmful chemical substances, Compliant with **RoHS** Directive
- **Power consumption: 0.35 W**
(in case of 24 VDC)



VNA

VNB

SGC

VNC

VNH

VND

VCC

(In case of an air operated valve)

Dry bearings

Prevents the shaft, which is a sliding part, from vibrating and helps to extend the service life of the rubber components and improves the seal performance of the main valve.

Squeeze seal

Completely shuts off the leakage of liquid coolant and increases the scraper effects. These two safety designs result in a dual advantage.

Scraper

Prevents foreign materials from entering, while the main valve is activated.

- Choice of seal materials
NBR, FKM

Auto switch

Able to confirm whether the valve is open/closed.
Mountable on the 2 sides.

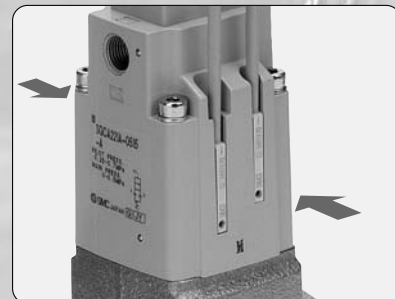

• Magnet

Grease channel

Prevents the loss of grease and helps to extend the service life.

IN →

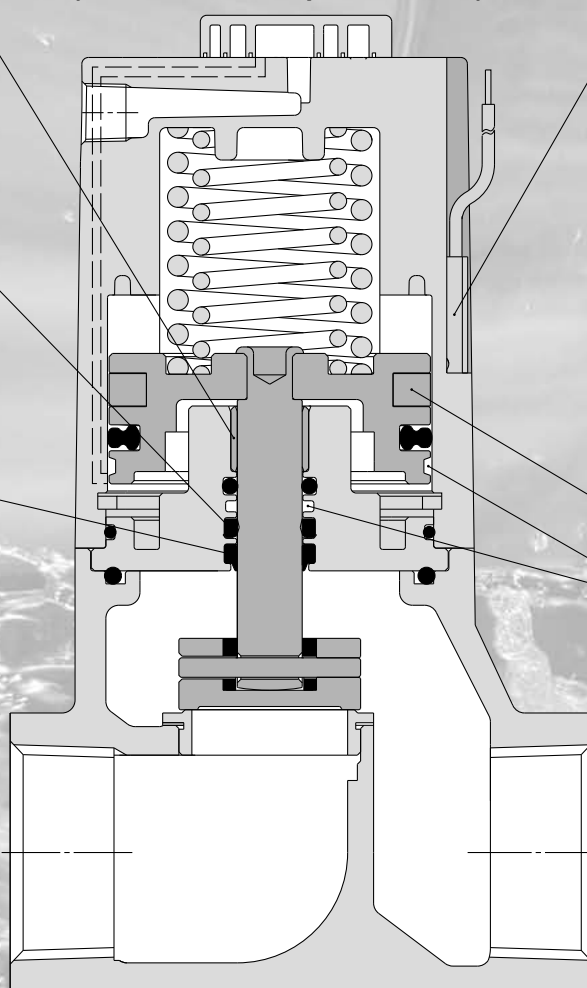

→ **OUT**

Variation (Common specifications for solenoid valve and air operated valve)

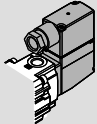
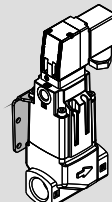
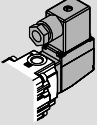
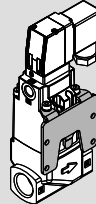
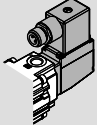
Series	Port size	Thread type	Type of actuation	Operating pressure range (MPa)	Av factor x 10 ⁻⁶ m ²	Electrical entry (in case of a solenoid valve)	Bracket
SGC2	3 / 8 (10A)	Rc G (ISO1179-1) NPT NPTF	N.C / N.O	0.5	110	• Conduit terminal 	• Bracket on the left side 
				1	85		
	1 / 2 (15A)			1.6	30	• DIN terminal 	• Bracket on the right side 
				0.5	155		
SGC3	3 / 4 (20A)			1	116	• M12 connector 	
				1.6	64		
				0.5	284		
SGC4	1 (25A)			1	170		
		1.6	109				
		0.5	440				
		1	265				
		1.6	174				

Coolant Blow Energy Saving

Coolant pump

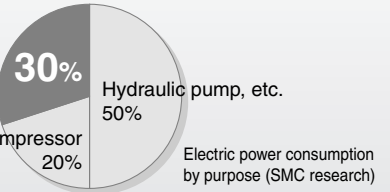

Research has revealed that coolant pumps account for 30% of the electric power consumption in a production facility. By reducing the energy consumed by the coolant pump it will substantially contribute to the electric reduction in the whole factory.

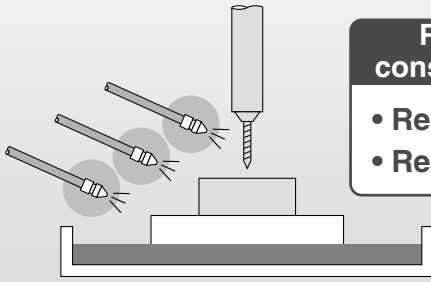

Reduction of electric power consumption of the coolant pump

- Reducing the number of pumps
- Reducing the size of pumps

Improvement Example case 1 Improvement of Pressure Loss

Before improvement

After improvement

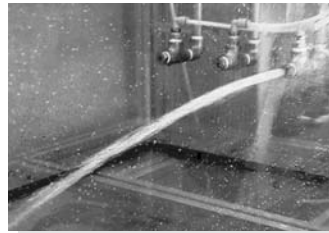

Pressure loss is improved by making the effective area ratio 2 : 1 between the upstream side and the nozzle.

- Making the effective area in the upstream side larger. (Changing to the equipment with larger effective area)
- Attaching a nozzle.

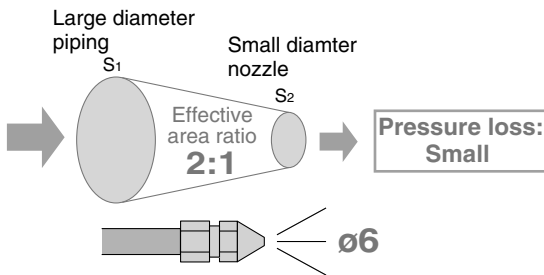
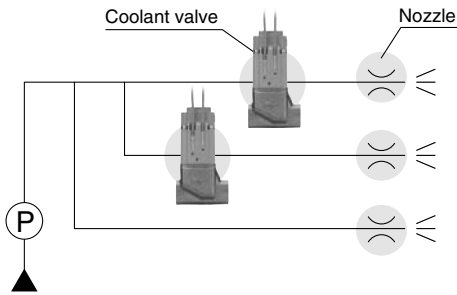

Effect of Energy Saving Improvement

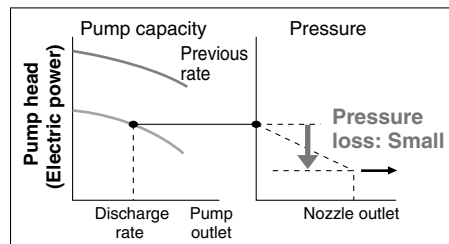

Electric power consumption

75% reduction

Improvement Example case 2 Intermittent Blow

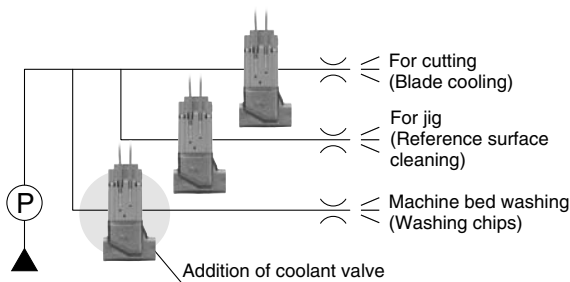

Stops machine bed-washing all the time. Machine bed washing is stopped when blowing for cutting or jig by means of a valve.

Effect of Energy Saving Improvement

Electric power consumption

20 to 50% reduction

Coolant flow per cycle

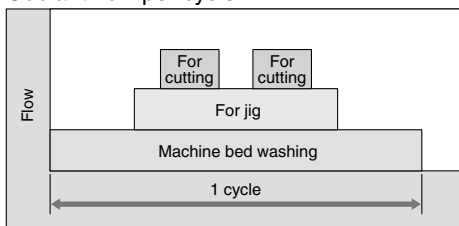

Coolant flow per cycle

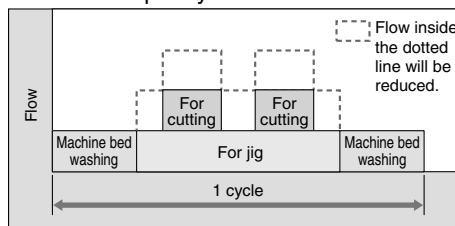

VNA

VNB

SGC

VNC

VNH

VND

VCC

Coolant Blow System / Related Equipment

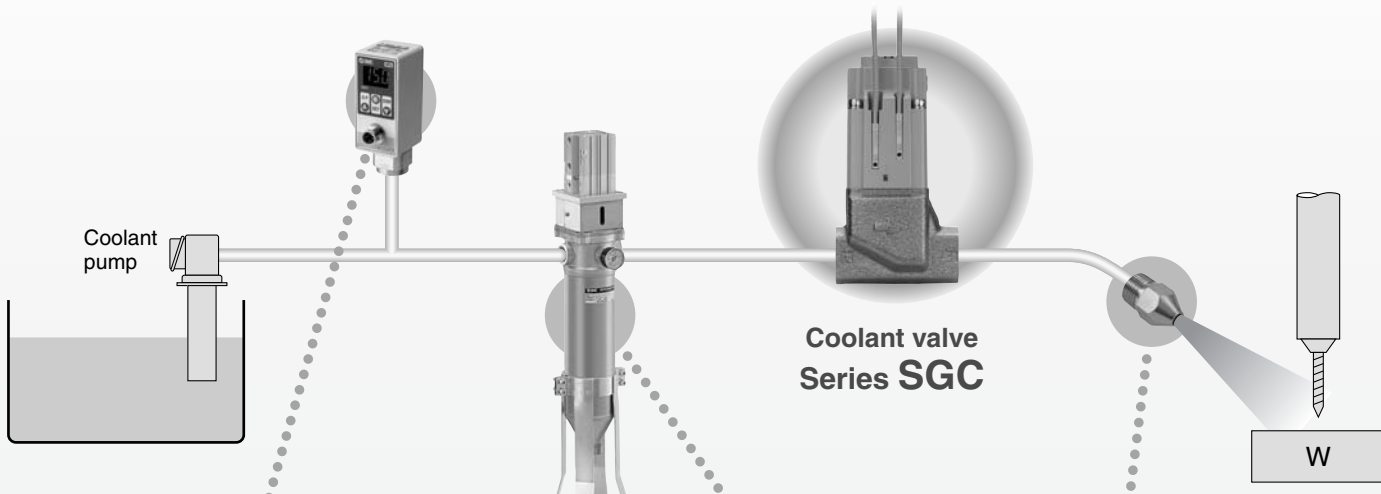

Pressure Switches P.393

Coolant line pressure control

- 2-color display high precision digital pressure switch **ISE80**
- 2-color display digital pressure switch **ISE75/75H**
- General purpose pressure switch **ISG**

Industrial Filters P.391

Coolant liquid filtration

- Industrial filter **FG**
- Bag filter **FGF**
- Low maintenance filter **FN**

Nozzles for Blow P.390

- Nozzle for blow **KN**

Energy Saving Related Material



Pneumatic model selection program Pneumatic cylinder drive system (Ver 3.00)

Automatically selects the most appropriate smallest products to match your energy saving needs.

* This program is also available from the SMC Web site.

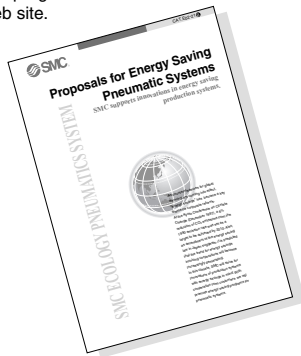

Proposals for Energy Saving Pneumatic Systems (CAT. E02-21)

Introducing our energy saving themes including case studies as well as our energy saving related equipment.



Energy Saving Program (Ver.3.1)

Energy saving planning, improvements, and calculation of coolant circuits is possible.

* This program is also available from the SMC Web site.

Splash Proof Air Cylinders



Splash Proof Air Cylinders (E244)

Coolant Valve

Series SGC



How to Order



Made to order specifications
(For details, refer to page 389)

External pilot solenoid

SGC 2 2 1 A - 05 10 Y - 1 T Z - - A - -

Air operated

SGCA 2 2 1 A - 05 10 - - A - -

① ② ③ ④ ⑤ ⑥ ⑦ ⑧ ⑨ ⑩ ⑪ ⑫ ⑬ ⑭ ⑮

① Series

2	SGC200
3	SGC300
4	SGC400

② Valve type

1	Normally closed
2	Normally open

③ Seal material

A	NBR
B	FKM

④ Pressure range

05	Pressure range 0 to 0.5 MPa
10	Pressure range 0 to 1 MPa
16	Pressure range 0 to 1.6 MPa

⑤ Thread type

Nil	Rc
G	G (ISO1179-1)
N	NPT
T	NPTF

⑥ Port size

10	3/8	SGC200
15	1/2	
20	3/4	SGC300
25	1	SGC400

⑦ Pilot valve

Y	V116
---	------

⑧ Rated voltage

1	100 VAC 50/60 Hz
2	200 VAC 50/60 Hz
3	110 VAC [115 VAC] 50/60 Hz
4	220 VAC [230 VAC] 50/60 Hz
5	24 VDC
6	12 VDC

Note) Refer to the back of page 394 when using with energization for long periods of time.

⑨ Electrical entry

T: Conduit terminal 	D: DIN terminal (Pitch between the terminals: 11 mm) 	DO: DIN terminal without connector 	W: M12 connector Note)
--------------------------------	---	---	-----------------------------------

Note 1) Cable is not included. Order it separately after referring to the options on page 379.
Note 2) Refer to the table (1) below for combinations with light/surge voltage suppressors.

⑩ Light / surge voltage suppressor

Nil	None
S	With surge voltage suppressor
Z	With light / surge voltage suppressor

Note) Refer to Table (1) below for combinations with electrical entry.

* DOS, DOZ are not available.
* For AC specifications, NIL is only set for Electrical entry DO.

⑪ Manual override

Nil: Non-locking push type 	D: Push-turn locking lever type
---------------------------------------	--

⑫ Bracket mounting position

Nil: Without bracket 	B1: Bracket on the left side 	B2: Bracket on the right side
---------------------------------	---	--

Note) Bracket cannot be attached later.

Table (1) Electrical entry/Light/Surge Voltage Suppressor

Voltage	Electrical entry	Without light/surge voltage suppressor	With surge voltage suppressor	With light/surge voltage suppressor
		Nil	S	Z
AC	T	—	●	●
	D	—	●	●
	W	—	—	—
	DO	● Note)	—	—
DC	T	●	●	●
	D	●	●	●
	W	—	—	—
	DO	●	—	—

Note) If a AC specification without DIN Terminal (DO) is selected, always use a DIN connector with surge voltage suppressor as the connector.

⑬ Auto switches (for verifying whether the valve is open/closed)

Nil	Without auto switch (without magnet)
M	Without auto switch (with built-in magnet)
A	With auto switch Select a model, referring to the table "Applicable Auto Switches" below.
B	
C	
E	
F	
G	

* The auto switches are included when shipped (unmounted).

⑭ Lead wire length

Nil	0.5 m
M	1 m
L	3 m
Z	5 m

* 0.5m (Nil), 1m (M), and 5m (Z) for D-M9□A will be produced on receipt of order.

⑮ Number of auto switches

Nil	2 pcs.
S	1 pc.

Applicable auto switches / Refer to page 385 to 388 for detailed auto switch specifications.

Solid state auto switch

Symbol	Part no. In-line	Special function	Electrical entry	Indicator light	Wiring (Output)	Load voltage		Applicable load	
						DC			
A	D-M9N	—	Grommet	Yes	3-wire (NPN)	24 V	5 V, 12 V	IC circuit	Relay, PLC
B	D-M9P				3-wire (PNP)		12 V		
C	D-M9B				2-wire				
E	D-M9NA	Water resistance (2-color display)	Grommet	Yes	3-wire (NPN)	24 V	5 V, 12 V	IC circuit	Relay, PLC
F	D-M9PA				3-wire (PNP)		12 V		
G	D-M9BA				2-wire				

Option

(For detail, refer to page 384)

Cable for M12 connector

V100-200-1-4

Specification

1	For DC
2	For AC

Cable length (L)

4	1000 [mm]
8	3000 [mm]
9	5000 [mm]

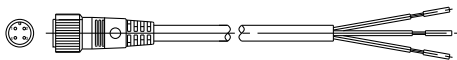

VNA

VNB

SGC

VNC

VNH

VND

VCC

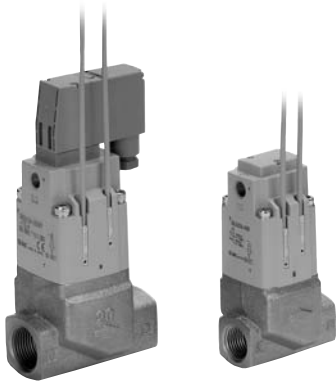

Characteristics

Pressure specification	Model	Port size	Orifice dia. ϕ (mm)	Flow characteristics $Av \times 10^{-6} m^2$	Cv factor converted	Mass (kg)	
						Air operated type	External pilot solenoid type
0.5 MPa	SGC(A)22□□-05□10	3/8	$\phi 15$	110	4.6	0.69 (0.74)	0.73 (0.78)
	SGC(A)22□□-05□15	1/2	$\phi 15$	155	6.5	0.69 (0.74)	0.73 (0.78)
	SGC(A)32□□-05□20	3/4	$\phi 20$	284	11.8	1.04 (1.11)	1.08 (1.15)
	SGC(A)42□□-05□25	1	$\phi 25$	440	18.3	1.70 (1.77)	1.74 (1.81)
1.0 MPa	SGC(A)22□□-10□10	3/8	$\phi 12$	85	3.5	0.69 (0.74)	0.73 (0.78)
	SGC(A)22□□-10□15	1/2	$\phi 12$	116	4.8	0.69 (0.74)	0.73 (0.78)
	SGC(A)32□□-10□20	3/4	$\phi 14$	170	7.1	1.04 (1.11)	1.08 (1.15)
	SGC(A)42□□-10□25	1	$\phi 17$	265	11.0	1.70 (1.77)	1.74 (1.81)
1.6 MPa	SGC(A)22□□-16□10	3/8	$\phi 9$	30	1.25	0.69 (0.74)	0.73 (0.78)
	SGC(A)22□□-16□15	1/2	$\phi 9$	64	2.7	0.69 (0.74)	0.73 (0.78)
	SGC(A)32□□-16□20	3/4	$\phi 12$	109	4.5	1.04 (1.11)	1.08 (1.15)
	SGC(A)42□□-16□25	1	$\phi 15$	174	7.3	1.70 (1.77)	1.74 (1.81)

* (): Mass including the bracket
 * Add the mass of an auto switch additionally.

JIS Symbol

Type of actuation	Normally closed	Normally open
Air operated type	SGCA□□21□ 	SGCA□□22□
	SGC□□21□ 	SGC□□22□

Valve Specification

Operating fluid		Coolant	
Fluid temperature	SGC□□□□A, B	-5 to 60°C*	
Ambient temperature		-5 to 50°C*	
Proof pressure		2.4 MPa	
Leakage from the valve seat		20 cm ³ /min or less (water pressure)	
Operating pressure range	SGC□□□□□-05	0 to 0.5 MPa	
	SGC□□□□□-10	0 to 1 MPa	
	SGC□□□□□-16	0 to 1.6 MPa	
External air operated	Pres- sure	SGC□□□1	0.25 to 0.7 MPa
		SGC□□□2	0.5 MPa specification: 0.25 MPa to 0.7 MPa 1.0, 1.6 MPa specification: 0.3 MPa to 0.7 MPa
	Lubrication	Not required (Use turbine oil Class 1 (ISO VG32), if lubricated.)	
Temperature		-5 to 50°C*	

* No freezing

Pilot Solenoid Valve Specification

Pilot solenoid valve specification		V116-□□□-1
Electrical entry		Conduit terminal, DIN terminal, M12 connector
Coil rated voltage V	DC	12 V, 24 V
	AC (50/60 Hz)	100 V, 110 V, 200 V, 220 V
Allowable voltage fluctuation		±10% of rated voltage*
Power consumption W	DC	0.35 W (With indicator light: 0.58 W)
	AC	0.78 (With indicator light: 0.87) 0.86 (With indicator light: 0.97) [0.94 (With indicator light: 1.07)] 1.15 (With indicator light: 1.30) 1.27 (With indicator light: 1.46) [1.39 (With indicator light: 1.60)]
Surge voltage suppressor		Varistor
Indicator light		LED (Neon bulb when AC with DIN terminal and M12 connector)
Enclosure		IEC60529 standard IP65, JISC0920

* In common between 110 VAC and 115 VAC, and between 220 VAC and 230 VAC.
 * For 115 VAC and 230 VAC, the allowable voltage is -15% to +5% of rated voltage.

How to Order Pilot Valve

V116-**5****T****Z**-1
 ① ② ③

① Rated voltage

1	100 VAC 50/60 Hz
2	200 VAC 50/60 Hz
3	110 VAC [115 VAC] 50/60 Hz
4	220 VAC [230 VAC] 50/60 Hz
5	24 VDC
6	12 VDC

② Electrical entry

T	Conduit terminal
D	DIN terminal (with connector)
DO	DIN terminal (without connector)
W	M12 connector

③ Light / surge voltage suppressor

Nil	None
S	With surge voltage suppressor
Z	With light / surge voltage suppressor

Note 1) Refer to Table (1) on page 378 for combinations with electrical entry.
 * DOS, DOZ are not available.
 * For AC specifications, NIL is only set for electrical entry DO.

Construction

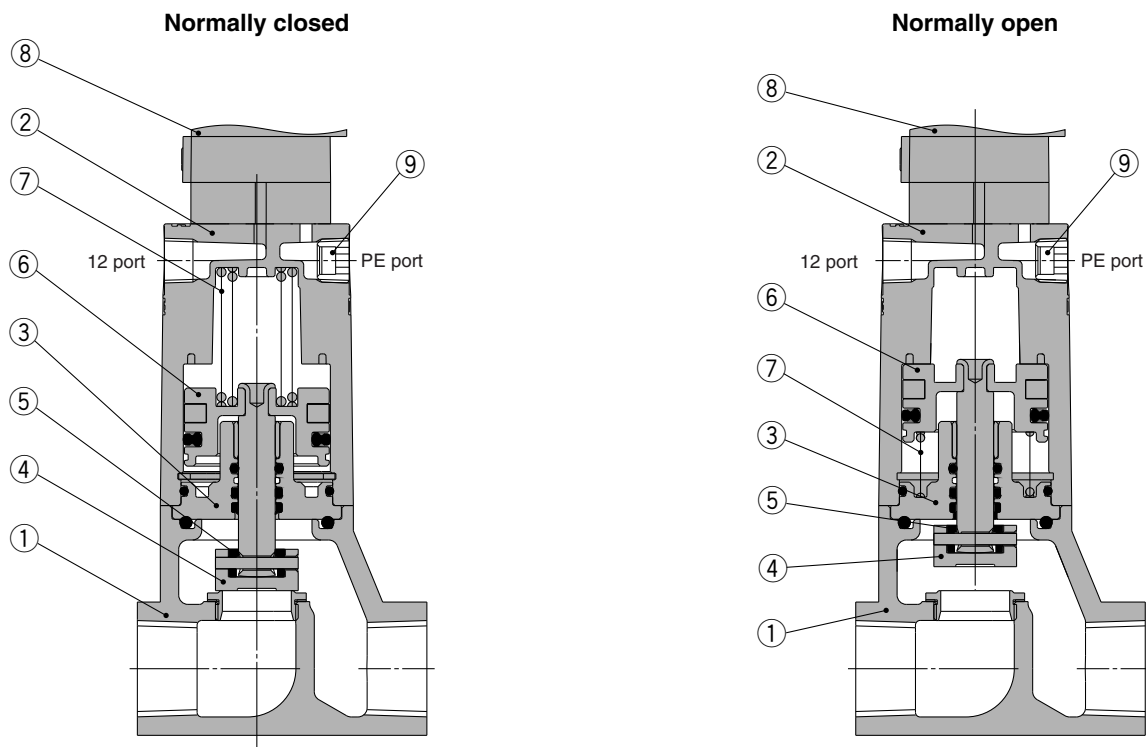

Component Parts

No.	Description	Material	Note
1	Body assembly	Cast iron	Plated
2	Cover assembly	Aluminum die-casted	White
3	Plate assembly	Iron	Valve component, NBR, FKM
4	Valve body	Stainless steel	
5	Valve cover	NBR, FKM	
6	Piston assembly	Stainless steel, Aluminum	
7	Return spring	Stainless steel, Piano wire	
8	Pilot solenoid valve	—	
9	Filter	Copper	

VNA

VNB

SGC

VNC

VNH

VND

VCC

Series SGC

Dimensions

Air operated type

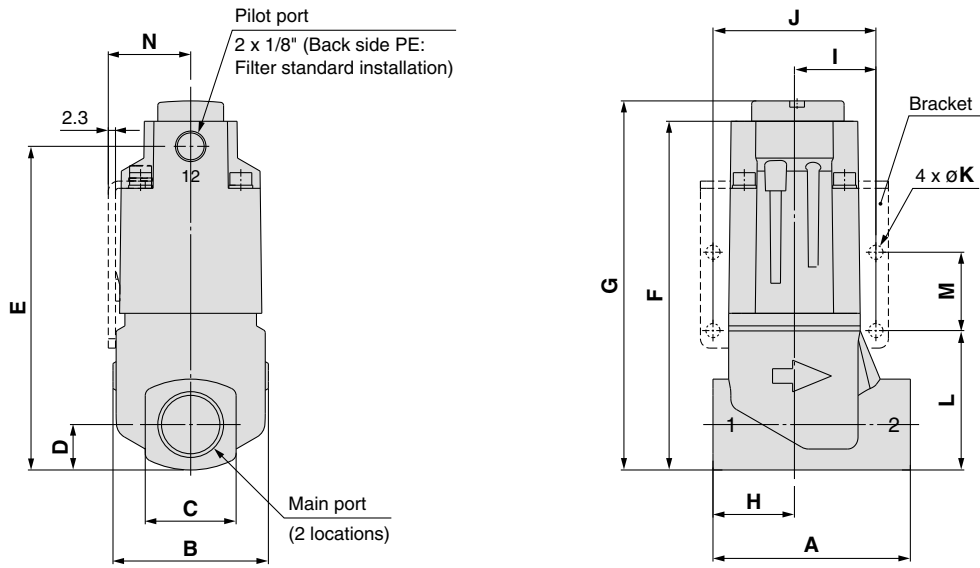

Model	Main port	A	B	C	D	E	F	G	H	I	J	K	L	M	N
SGCA2□□□-□□10	3/8	63	49.6	29	14.5	103.3	111.3	117.8	26	26	52	4.5	44.5	25	26.3
SGCA2□□□-□□15	1/2	63	49.6	29	14.5	103.3	111.3	117.8	26	26	52	4.5	44.5	25	26.3
SGCA3□□□-□□20	3/4	80	59	35	17.5	112	120.5	127	35	31	62	5.5	48	30	31
SGCA4□□□-□□25	1	90	74	44	22	135.9	144.5	151	40	36	72	6.5	60	35	39.5

External pilot solenoid type (Conduit terminal)

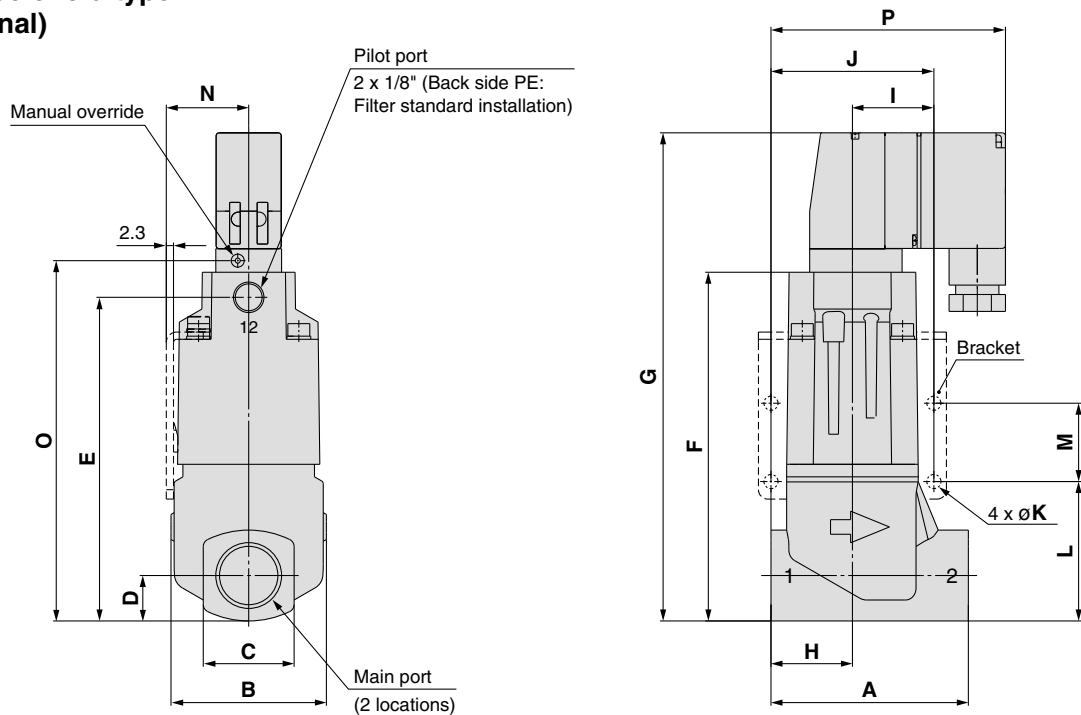

Model	Main port	A	B	C	D	E	F	G	H	I	J	K	L	M	N	O	P
SGC2□□□-□□10	3/8	63	49.6	29	14.5	103.3	111.3	155.8	26	26	52	4.5	44.5	25	26.3	115	74.2
SGC2□□□-□□15	1/2	63	49.6	29	14.5	103.3	111.3	155.8	26	26	52	4.5	44.5	25	26.3	115	74.2
SGC3□□□-□□20	3/4	80	59	35	17.5	112	120.5	165	35	31	62	5.5	48	30	31	124.2	80.1
SGC4□□□-□□25	1	90	74	44	22	135.9	144.5	189	40	36	72	6.5	60	35	39.5	148.2	91.1

Dimensions

External pilot solenoid type (DIN terminal)

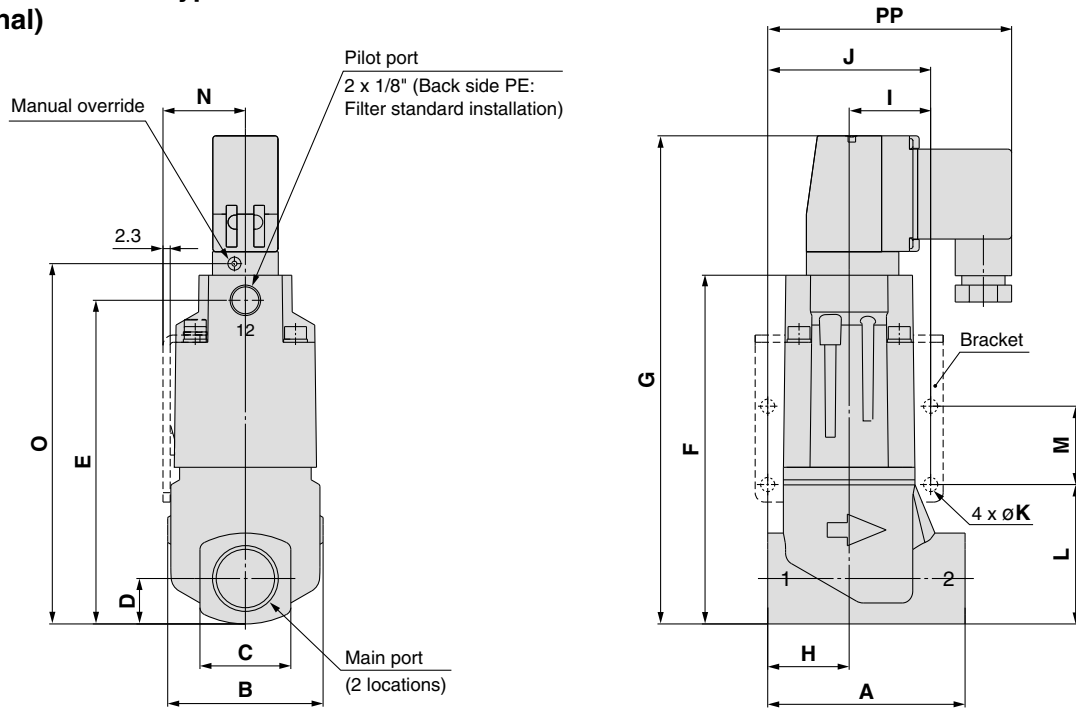

External pilot solenoid type (M12 connector)

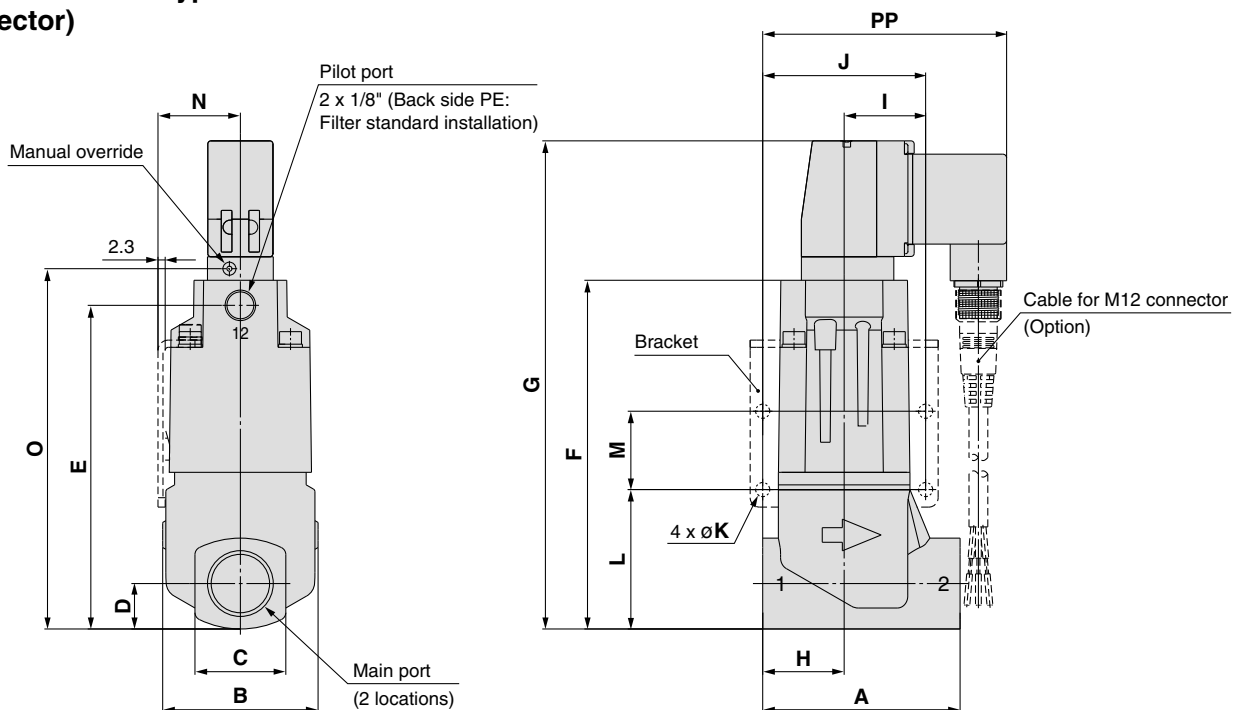

Model	Main port	A	B	C	D	E	F	G	H	I	J	K	L	M	N	O	PP
SGC2□□□-□□10	3/8	63	49.6	29	14.5	103.3	111.3	155.8	26	26	52	4.5	44.5	25	26.3	115	79.9
SGC2□□□-□□15	1/2	63	49.6	29	14.5	103.3	111.3	155.8	26	26	52	4.5	44.5	25	26.3	115	79.9
SGC3□□□-□□20	3/4	80	59	35	17.5	112	120.5	165	35	31	62	5.5	48	30	31	124.2	85.8
SGC4□□□-□□25	1	90	74	44	22	135.9	144.5	189	40	36	72	6.5	60	35	39.5	148.2	96.8

VNA

VNB

SGC

VNC

VNH

VND

VCC

Series SGC

How to Fix an Auto Switch

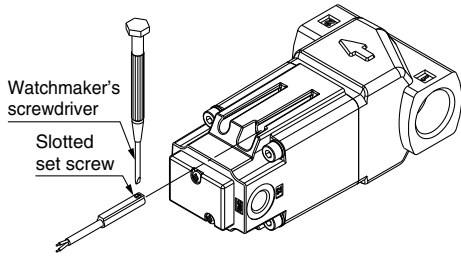

When tightening an auto switch mounting screw, use a watchmaker's screwdriver with a handle of approximately 5 to 6 mm in diameter. Furthermore, use a tightening torque of approximately 0.05 to 0.15 N•m.

Auto Switch Proper Mounting Position

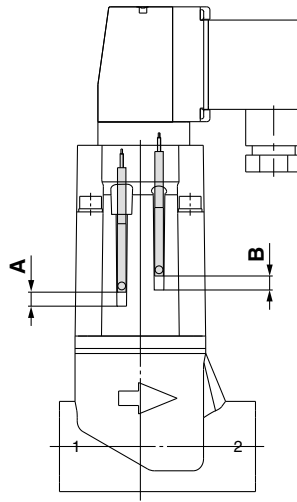

(mm)

Model	D-M9□	
SGC(A)2□□□-05□10, 15	A	5
	B	5
SGC(A)2□□□-10□10, 15	A	6
	B	5
SGC(A)2□□□-16□10, 15	A	7
	B	5
SGC(A)3□□□-05□20	A	4
	B	4
SGC(A)3□□□-10□20	A	6
	B	4
SGC(A)3□□□-16□20	A	7
	B	4
SGC(A)4□□□-05□25	A	3
	B	3
SGC(A)4□□□-10□25	A	6
	B	3
SGC(A)4□□□-16□25	A	7
	B	3

* The above dimensions including a mounted auto switch are for reference only. Please be sure that the auto switch works appropriately.

Option

Cable for M12 connector (Female connector with cable)

V100-200-**1**-**4**

Specification

1	For DC
2	For AC

Cable length (L)

4	1000 [mm]
8	3000 [mm]
9	5000 [mm]

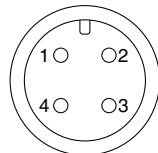
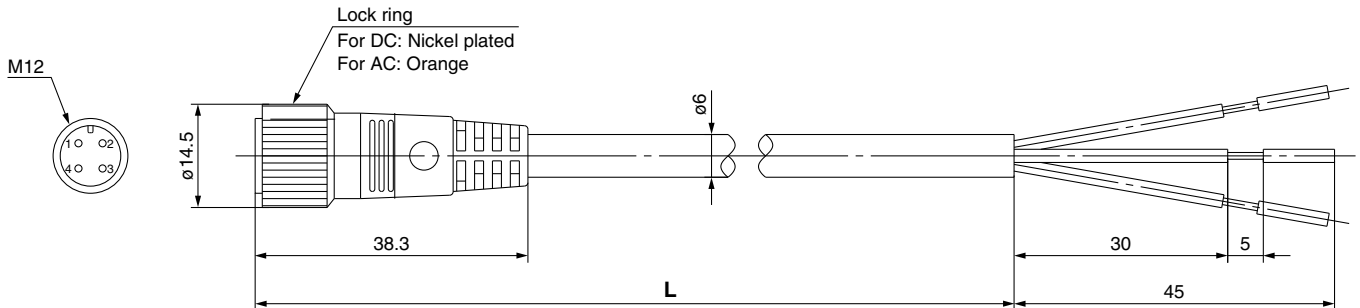

Socket pin connector pin assignment

Terminal no.

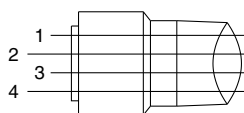

Cable colors
Cable cover colors for core wire

BROWN: Grounding
WHITE: Not used
BLUE: Power supply for valve
BLACK: Power supply for valve

Connections

How to Order

Include the part number of the female connector with cable together with the part number for the solenoid valve.

Example) In case of lead wire length, 1,000 mm

For DC
SGC221A-0510Y-5WZ
V100-200-1-4

For AC
SGC221A-0510Y-1WZ
V100-200-2-4

Series SGC

Auto Switch Specifications

Auto Switch Common Specifications

Type	Solid state auto switch
Leakage current	3-wire: 100 μ A or less 2-wire: 0.8 mA or less
Operating time	1 ms or less
Impact resistance	1000 m/s ²
Insulation resistance	50 M Ω or more at 500 VDC Mega (between lead wire and case)
Withstand voltage	1000 VAC for 1 minute (between lead wire and case)
Ambient temperature	-10 to 60°C
Enclosure	IEC60529 standard IP67
Standard	CE marking

Lead Wire Length

Lead wire length indication

(Example) **D-M9P**L

Lead wire length

Nil	0.5 m
M	1 m
L	3 m
Z	5 m

Note 1) Applicable auto switch with 5 m lead wire "Z" Manufactured upon receipt of order as standard.

Note 2) Lead wire length of 1 m(M) is only available for DM9□. For DM9□, it will be made upon request.

VNA

VNB

SGC

VNC

VNH

VND

VCC

Series SGC Auto Switch Connections and Examples

Basic Wiring

Solid state 3-wire, NPN

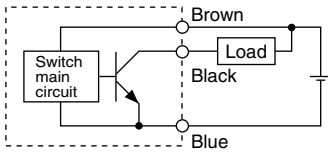

Solid state 3-wire, PNP

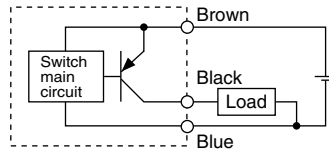

Solid state 2-wire

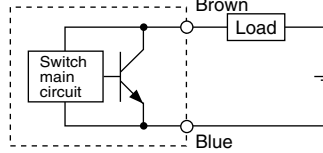

(Power supplies for switch and load are separate.)

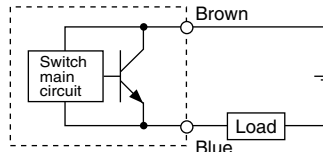
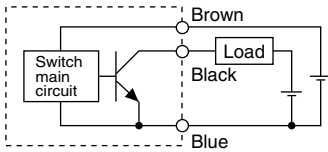

Example of Connection to PLC (Programmable Logic Controller)

• Sink input specifications 3-wire, NPN

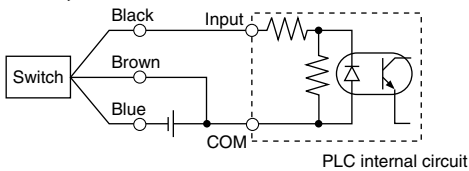

• Source input specifications 3-wire, PNP

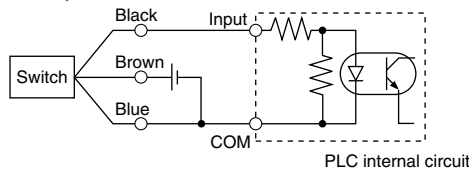

Connect according to the applicable PLC input specifications, since the connection method will vary depending on the PLC input specifications.

2-wire

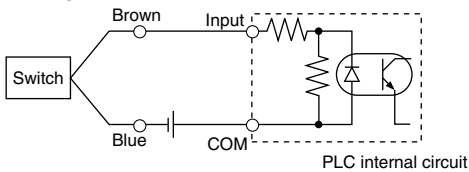

2-wire

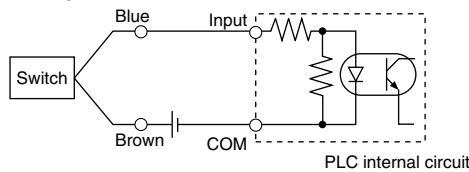

Example of AND (Serial) and OR (Parallel) Connection

• 3-wire

AND connection for NPN output (using relays)

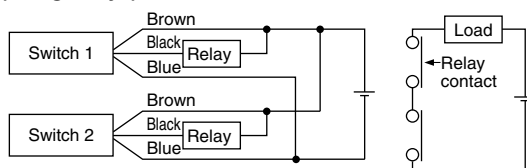

AND connection for NPN output (performed with switches only)

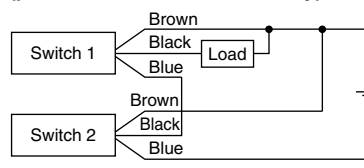

OR connection for NPN output

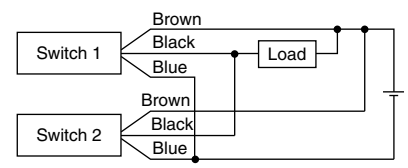

The indicator lights will illuminate when both auto switches are turned ON.

2-wire with 2-switch AND connection

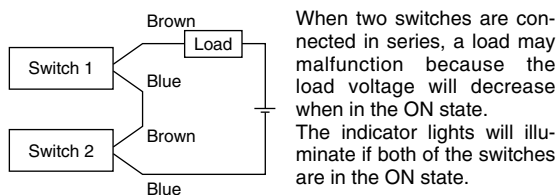

When two switches are connected in series, a load may malfunction because the load voltage will decrease when in the ON state. The indicator lights will illuminate if both of the switches are in the ON state.

$$\begin{aligned} \text{Load voltage at ON} &= \text{Power supply} - \text{Residual voltage} \times 2 \text{ pcs.} \\ &= 24 \text{ V} - 4 \text{ V} \times 2 \text{ pcs.} \\ &= 16 \text{ V} \end{aligned}$$

Example: Power supply is 24 VDC.
Internal voltage drop in switch is 4 V.

2-wire with 2-switch OR connection

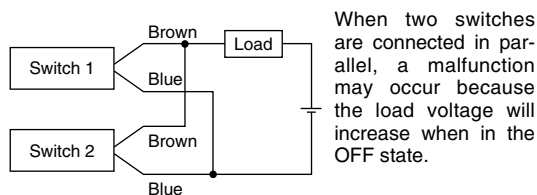

When two switches are connected in parallel, a malfunction may occur because the load voltage will increase when in the OFF state.

$$\begin{aligned} \text{Load voltage at OFF} &= \text{Leakage current} \times 2 \text{ pcs.} \\ &\quad \times \text{Load impedance} \\ &= 1 \text{ mA} \times 2 \text{ pcs.} \times 3 \text{ k}\Omega \\ &= 6 \text{ V} \end{aligned}$$

Example: Load impedance is 3 kΩ.
Leakage current from switch is 1 mA.

Solid State Auto Switch Direct Mounting Style D-M9N/D-M9P/D-M9B



Refer to SMC website for the details of the products conforming to the international standards.

Auto Switch Specifications

PLC: Programmable Logic Controller

D-M9□ (With indicator light)			
Auto switch model	D-M9N	D-M9P	D-M9B
Electrical entry direction	In-line	In-line	In-line
Wiring type	3-wire		2-wire
Output type	NPN	PNP	—
Applicable load	IC circuit, Relay, PLC		24 VDC relay, PLC
Power supply voltage	5, 12, 24 VDC (4.5 to 28 V)		
Current consumption	10 mA or less		
Load voltage	28 VDC or less	—	24 VDC (10 to 28 VDC)
Load current	40 mA or less		2.5 to 40 mA
Internal voltage drop	0.8 V or less at 10 mA (2 V or less at 40 mA)		4 V or less
Leakage current	100 μA or less at 24 VDC		0.8 mA or less
Indicator light	Red LED illuminates when turned ON.		
Standard	CE marking		

Grommet

- 2-wire load current is reduced (2.5 to 40 mA).
- Flexibility is 1.5 times greater than the conventional model (SMC comparison).
- Using flexible cable as standard spec.



Caution

Precautions

Do not fix the auto switch with the existing screw installed on the auto switch body. The auto switch may be damaged if a screw other than the one supplied is used.

- Lead wires — Oilproof flexible heavy-duty vinyl cord: $\phi 2.7 \times 3.2$ ellipse, 0.15 mm², 2 cores (D-M9B), 3 cores (D-M9N, D-M9P)

Note 1) Refer to page 385 for solid state switch common specifications.

Note 2) Refer to page 385 for lead wire lengths.

Mass

(g)

Auto switch model	D-M9N	D-M9P	D-M9B
Lead wire length (m)	0.5	8	8
	1	14	14
	3	41	41
	5	68	68

Auto Switch Internal Circuit

D-M9N

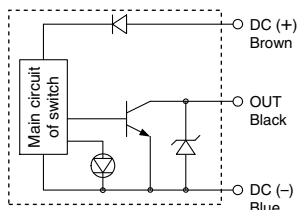

D-M9P

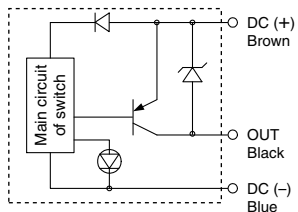

D-M9B

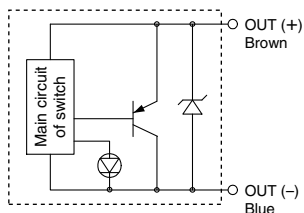

Dimensions

(mm)

D-M9□

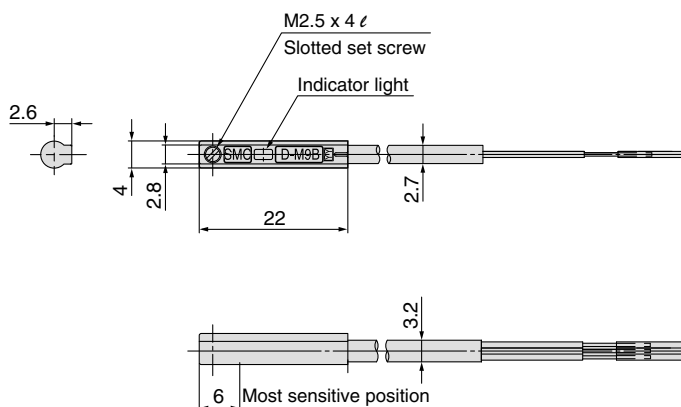

VNA

VNB

SGC

VNC

VNH

VND

VCC

Water Resistant 2-color Indication Type Solid State Auto Switch: Direct Mounting Style D-M9NA/D-M9PA/D-M9BA



Grommet

- Water (coolant) resistant type
- 2-wire load current is reduced (2.5 to 40 mA)
- The optimum operating position can be determined by the color of the light. (Red → Green ← Red)
- Using flexible cable as standard spec.



Caution

Precautions

Do not fix the auto switch with the existing screw installed on the auto switch body. The auto switch may be damaged if a screw other than the one supplied is used.

Auto Switch Internal Circuit

D-M9NA

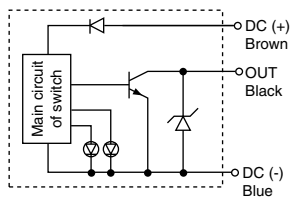

D-M9PA

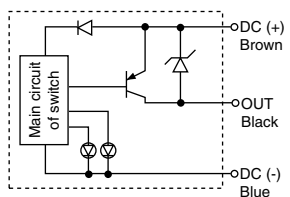

D-M9BA

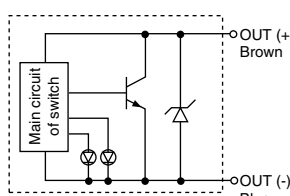

Indicator light/Display method

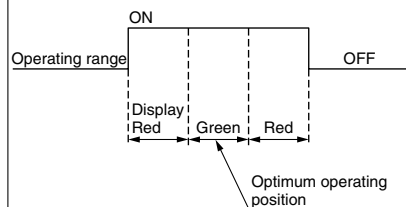

Auto Switch Specifications

PLC: Programmable Logic Controller

D-M9□A (With indicator light)			
Auto switch model	D-M9NA	D-M9PA	D-M9BA
Electrical entry direction	In-line	In-line	In-line
Wiring type	3-wire		2-wire
Output type	NPN	PNP	—
Applicable load	IC circuit, Relay, PLC		24 VDC relay, PLC
Power supply voltage	5, 12, 24 VDC (4.5 to 28 V)		—
Current consumption	10 mA or less		—
Load voltage	28 VDC or less	—	24 VDC (10 to 28 VDC)
Load current	40 mA or less		2.5 to 40 mA
Internal voltage drop	0.8 V or less at 10 mA (2 V or less at 40 mA)		4 V or less
Leakage current	100 μA or less at 24 VDC		0.8 mA or less
Indicator light	Operating positionRed LED illuminates Optimum operating positionGreen LED illuminates		
Standard	CE marking		

- Lead wires — Oilproof flexible heavy-duty vinyl cord: $\phi 2.7 \times 3.2$ ellipse, 0.15 mm², 2 cores (D-M9BA), 3 cores (D-M9NA, D-M9PA)

Note 1) Refer to page 385 for solid state switch common specifications.

Note 2) Refer to page 385 for lead wire lengths.

Mass

(g)

Auto switch model	D-M9NA	D-M9PA	D-M9BA	
Lead wire length (m)	0.5	8	8	7
	1	14	14	13
	3	41	41	38
	5	68	68	63

Dimensions

(mm)

D-M9□A

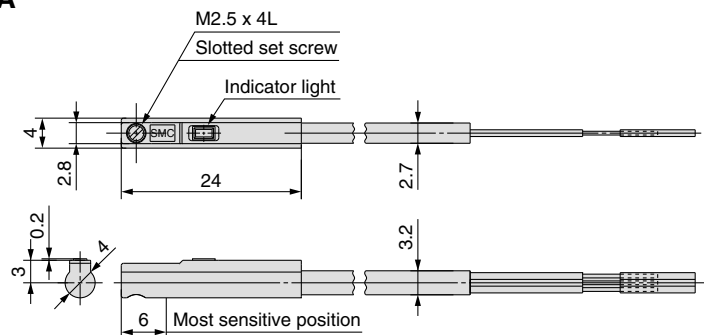

Made to Order Pilot Valve: SF4

SGC **2** **2** **1** **A** - **05** **G** **10** - **1** **T** **Z** - **B1** - **A** **L** **S** - **X1**

① ② ③ ④ ⑤ ⑥ ⑦ ⑧ ⑨ ⑩ ⑪ ⑫ ⑬ ⑭ ⑮

Pilot valve: SF4 ●

⑦ Pilot valve

Nil	SF4
-----	-----

⑧ Rated voltage

1	100 VAC 50/60 Hz
2	200 VAC 50/60 Hz
3	110 VAC 50/60 Hz
4	220 VAC 50/60 Hz
5	24 VDC
6	12 VDC
7	240 VAC 50/60 Hz
9	Others

⑪ Manual override

Nil	Push type
B	Slotted locking type

Equivalent to the standard models except for ⑦, ⑧, ⑪. Refer to page 378.

Pilot Solenoid Valve Specification

Pilot solenoid valve specification		SF4-□□□-50-X240	
Electrical entry		Conduit terminal, DIN terminal, M12 connector	
Coil rated voltage V	DC	24 V, Other (Option)	
	AC (50/60 Hz)	100 V, 200, Other (Option)	
Allowable voltage fluctuation		-15 to 10% of rated voltage	
Power consumption W	DC	1.8 W (With indicator light: 2 W)	
Apparent voltage VA	AC	Inrush	5.6 VA (50 Hz) 5.0 VA (60 Hz)
		Holding	3.4 VA (50 Hz) 2.3 VA (60 Hz)
Light / surge voltage suppressor	DC	ZNR (Varistor), LED (Neon bulb for 100 V or more)	
	AC	ZNR (Varistor), Neon bulb (LED for less than 100 V)	

How to Order Pilot Valve

SF4 - **5** **T** **Z** - **50** - **X240**

① ② ③ ④

① Rated voltage

1	100 VAC 50/60 Hz
2	200 VAC 50/60 Hz
3	110 VAC 50/60 Hz
4	220 VAC 50/60 Hz
5	24 VDC
6	12 VDC
7	240 VAC 50/60 Hz
9	Others

② Electrical entry

T	Conduit terminal
D	DIN terminal (with connector)
DO	DIN terminal (without connector)
W	M12 connector

④ Manual override

Nil	Push type
B	Slotted locking type

③ Light / surge voltage suppressor

Nil	None
S	With surge voltage suppressor
Z	With light / surge voltage suppressor

* TS, DOS, DOZ are not available.

Dimensions

Equivalent to the standard models except the dimensions given in the diagram.

Conduit terminal

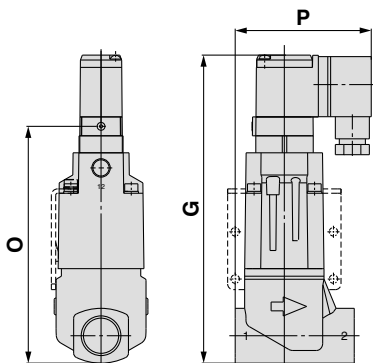

DIN terminal

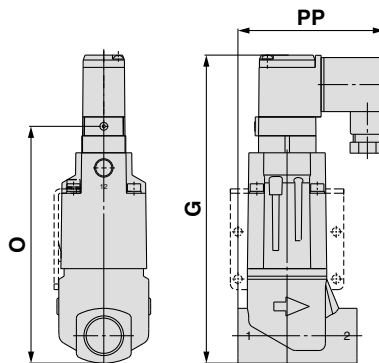

M12 connector

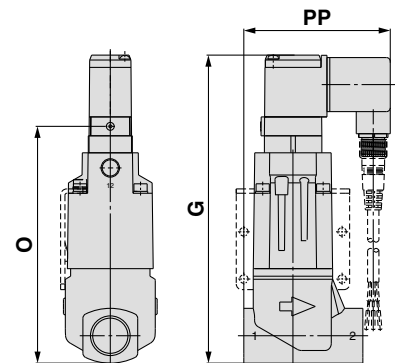

Model	Main port	G	O	P
SGC2□□□-□□10	3/8	163	125.3	72.8
SGC2□□□-□□15	1/2	163	125.3	72.8
SGC3□□□-□□20	3/4	172.2	134.5	78.7
SGC4□□□-□□25	1	196.2	158.5	89.7

Model	Main port	G	O	PP
SGC2□□□-□□10	3/8	163	125.3	79.1
SGC2□□□-□□15	1/2	163	125.3	79.1
SGC3□□□-□□20	3/4	172.2	134.5	85
SGC4□□□-□□25	1	196.2	158.5	96

Model	Main port	G	O	PP
SGC2□□□-□□10	3/8	163	125.3	79.1
SGC2□□□-□□15	1/2	163	125.3	79.1
SGC3□□□-□□20	3/4	172.2	134.5	85
SGC4□□□-□□25	1	196.2	158.5	96

VNA

VNB

SGC

VNC

VNH

VND

VCC

Related Products

Nozzles for Blow

Nozzle with Self-Align Fitting / KN

(mm)



Model	Nozzle diameter D	Connection size	With across flats		L1	L2
			H1	H2		
KN-10-400	ø4	ø10	14	17	29.5	17
KN-10-600	ø6	ø10	14	17	27.7	17
KN-12-400	ø4	ø12	17	19	41.3	17
KN-12-600	ø6	ø12	17	19	31.2	17
KN-16-400	ø4	ø16	22	24	40.1	17
KN-16-600	ø6	ø16	22	24	38.4	17
KN-20-400	ø4	ø20	26	27	45.6	17
KN-20-600	ø6	ø20	26	27	43.9	17

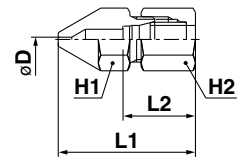

Nozzle with Male Thread / KN

(mm)



Model	Nozzle diameter D	Connection size	With across flats	L1	A*
			H1		
KN-R02-600	ø6	R1/4	14	27	21.1
KN-R03-400	ø4	R3/8	17	32	25.4
KN-R03-600	ø6	R3/8	17	30	23.7
KN-R04-400	ø4	R1/2	22	42	33.6
KN-R04-600	ø6	R1/2	22	40	31.8
KN-R06-600	ø6	R3/4	27	50	40.1
KN-R06-800	ø8	R3/4	27	48	38
KN-R10-800	ø8	R1	36	63	52.3

* Reference dimension of "R" thread after installation.

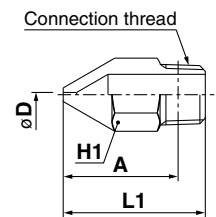

Pivoting Nozzle with Self-Align Fitting / KNK

(mm)



Model	Nozzle diameter D	Connection size	With across flats			L1	L2
			H1	H2	H3		
KNK-10-600	ø6	ø10	17	17	17	41.7	17
KNK-12-600	ø6	ø12	17	17	19	41.2	17
KNK-16-600	ø6	ø16	17	24	24	41.8	17
KNK-20-600	ø6	ø20	17	27	27	43.8	17

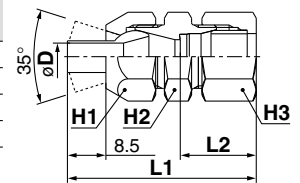

Pivoting Nozzle with Male Thread / KNK

(mm)



Model	Nozzle diameter D	Connection size	With across flats		L1	A*
			H1	H2		
KNK-R02-600	ø6	R1/4	17	17	38	31.9
KNK-R03-400	ø4	R3/8	17	17	39	32.4
KNK-R04-400	ø4	R1/2	17	22	42.2	34.1

* Reference dimension of "R" thread after installation.

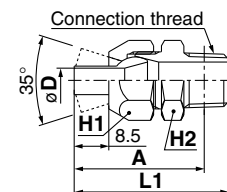

Related Products

Industrial Filters

Low Maintenance Filter

FN



FN1

FN4

Series	Port size	Temperature (°C)
FN1	Rc1	MAX.80
FN4	Rc2	
Features	<ul style="list-style-type: none"> · Element replacement not required. · Structure that enables automatic back-flushing of element. 	

Automatic back-flushing

System circuit allows the automatic back-flushing when the element is clogged.

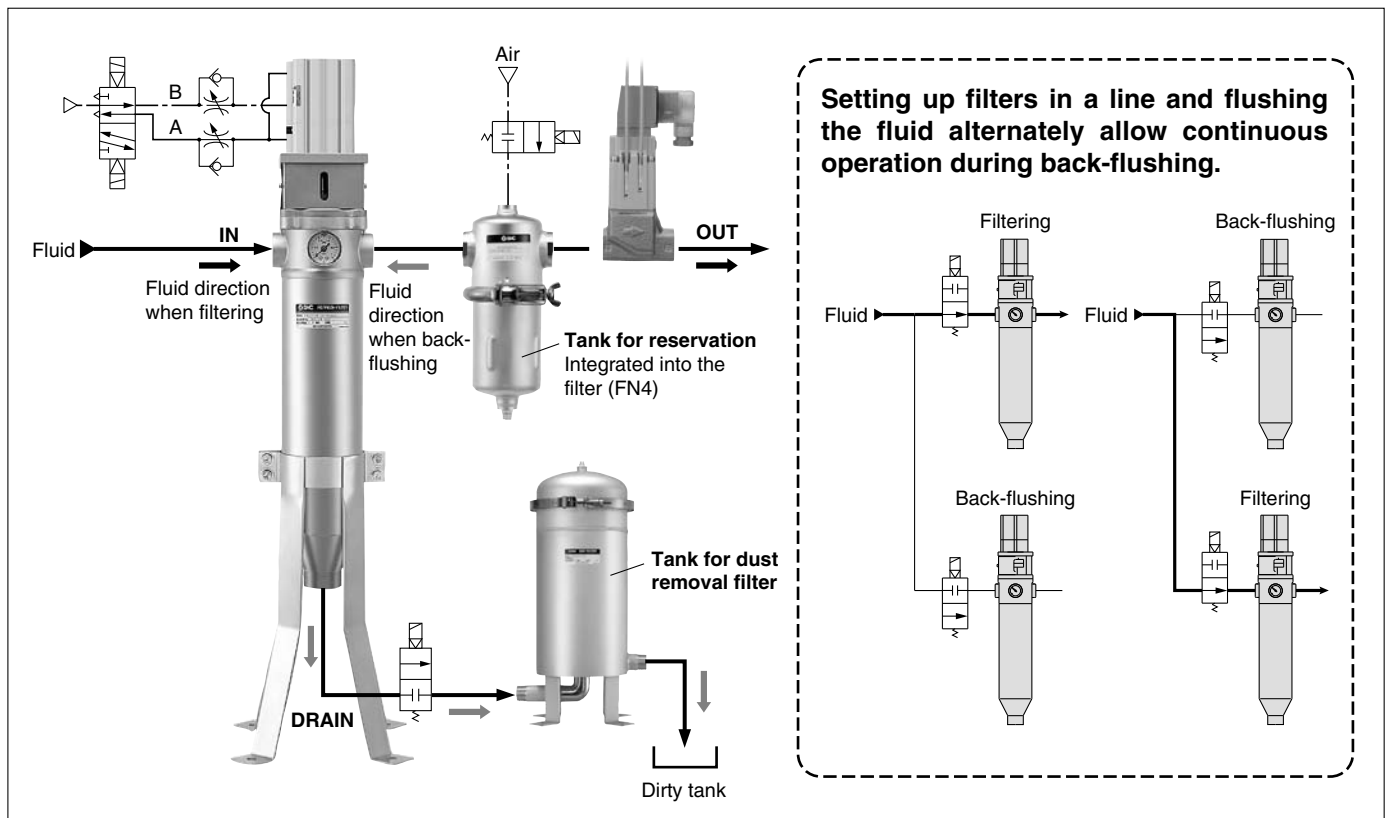

Filter for Cleaning Solvent Quick Change

FQ1



Series	Port size	Maximum operating pressure	Temperature (°C)
FQ1	Rc1/2, 3/4, 1	1 MPa	Max. 80
Features	<ul style="list-style-type: none"> · Low flow filtration (MAX. 30 l/min) · No tools required. · Takes only 60 seconds for element replacement. 		

VNA

VNB

SGC

VNC

VNH

VND

VCC

Related Products

Industrial Filter (Vessel type)

FGD



Series	Port size	Maximum operating pressure	Temperature (°C)
FGD	Rc3/8, 1/2, 3/4	0.7, 1 MPa	Max. 80
Features	<ul style="list-style-type: none"> · Low flow filtration. (MAX. 60 ℓ/min) · Antistatic specification (FGDE, FGDF) can be selected. 		

Industrial Filter (Vessel type)

FGE



Series	Port size	Maximum operating pressure	Temperature (°C)
FGE	R1, 2	0.7 MPa	Max. 80
Features	<ul style="list-style-type: none"> · Medium flow filtration. (MAX. 230 ℓ/min) · Easy element replacement with V band type (with cover splash prevention structure) 		

Industrial Filter (Vessel type)

FGG



Series	Port size	Maximum operating pressure	Temperature (°C)
FGG	Rc 2	0.7 MPa	Max. 80
Features	<ul style="list-style-type: none"> · Large flow filtration. (MAX. 350 ℓ/min) · Easy element replacement with V band type (with cover splash prevention structure) 		

Industrial Filter (Vessel type)

FGA



Series	Port size	Maximum operating pressure	Temperature (°C)
FGA	Flange: JIS 10KFF 25 to 15 D (1 ^B to 6 ^B)	1 MPa	Max. 80
Features	Large flow vertical element type (MAX. 3200 ℓ/min)		

Industrial Filter (Vessel type)

FGB



Series	Port size	Maximum operating pressure	Temperature (°C)
FGB	Flange: JIS 10KFF 25 to 15 D (1 ^B to 6 ^B)	1 MPa	Max. 80
Features	· Large flow suspended type (MAX. 3800 ℓ/min)		

Industrial Filter (Vessel type)

FGC



Series	Port size	Maximum operating pressure	Temperature (°C)
FGC	Flange: JIS 10KFF 25 to 15 D (1 ^B to 6 ^B)	1, 2, 4 MPa	Max. 80
Features	· High pressure and low flow rate type (MAX. 80 ℓ/min)		

Bag Filter

FGF



Series	Port size	Maximum operating pressure	Temperature (°C)
FGF	Rc 2, 4 ^B Flange, 6 ^B Flange	0.5 MPa	Max. 80
Features	<ul style="list-style-type: none"> · Highly effective for filtration of high temperature and high viscosity fluids · Ideal for large flow filtration. (MAX. 2000 ℓ/min) · Easy handling of filtered impurities 		

Related Products

Pressure Switches

2-Color Display High Accuracy Digital Pressure Switch

ISE



Series	Set pressure
ISE80	-0.105 to 1.1 MPa
ISE80H	-0.105 to 2.2 MPa
Features	<ul style="list-style-type: none"> · Stainless steel diaphragm applicable to various fluids · IP65 · With One-touch fittings (Straight, elbow type) · Rear ported, bottom ported

10 MPa/15 MPa 2-color Display Digital Pressure Switch

ISE



ISE75H

Series	Set pressure
ISE75	0.4 to 10 MPa
ISE75H	0.5 to 15 MPa
Features	<ul style="list-style-type: none"> 2-color display (Green and Red) · Irregular value at a glance Metal body type (Die-cast aluminum)

General Purpose Pressure Switch

ISG



Series	Set pressure
ISG11□, 21□	0.02 to 0.3 MPa
ISG12□, 22□	0.05 to 0.7 MPa
ISG13□, 23□	0.1 to 1.0 MPa
Features	For various fluids and waterproof

VNA

VNB

SGC

VNC

VNH

VND

VCC



Series SGC Specific Product Precautions 1

Be sure to read this before handling.

Refer to front matters 42 and 43 for Safety Instructions, and pages 17 to 19 for 2 Port Solenoid Valves for Fluid Control Precautions.

Design

Warning

Extended periods of continuous energization

If a valve is continuously energized for long periods, heat generation of the coil may result in reduced performance and shorter service life. This may also have an adverse effect on the peripheral equipment in proximity. Should a valve be continuously energized for long periods, or its daily energized state exceeds its non energized state, please use an energy saving type valve with DC specifications. Additionally, when using with AC, energizing for long periods of time continuously, select the air-operated valve and use the continuous duty type of the VT307 for a pilot valve.

Manual Override

Warning

Since connected equipment will be actuated when the manual override is operated, first confirm that conditions are safe.

Non-locking push type

Press in the direction of the arrow.

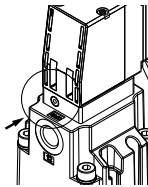

Push-turn locking slotted type [D type]

While pressing, turn in the direction of the arrow (90° clockwise). If it is not turned, it can be operated the same way as the non-locking type.

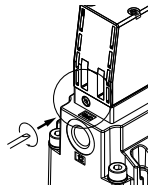

Caution

When operating the locking type D with a screwdriver, turn it gently using a flat head watchmaker's screwdriver. [Torque: Less than 0.1 N·m]

When locking the manual override on the push-turn locking type (D), be sure to push it down before turning. Turning without first pushing it down can cause damage to the manual override and trouble such as air leakage, etc.

Mounting

Warning

1. Do not apply external force to the coil section.

When tightening is performed, apply a wrench or other tool to the outside of the piping connection parts.

2. Do not warm the coil assembly with a heat insulator, etc.

Use tape, heaters, etc., for freeze prevention on the piping and body only. They can cause the coil to burn out.

3. Secure with brackets, except in the case of steel piping and copper fittings.

Mounting

Warning

4. Avoid sources of vibration, or adjust the arm from the body to the minimum length so that resonance will not occur.

5. When mounted in the vertical downward direction, foreign matter can remain in the plate assembly part if there are foreign matters in the coolant. For this reason, avoid mounting in the vertical downward direction as much as possible.

Wiring

Caution

1. Applied voltage

When electric power is connected to a solenoid valve, be careful to apply the proper voltage. Improper voltage may cause malfunction or coil damage.

2. Confirm the connections.

After completing the wiring, confirm that the connections are correct.

Light / Surge Voltage Suppressor

Caution

<For DC>

Conduit terminal, DIN terminal (non-polar type)

Surge voltage suppressor (TS/DS)

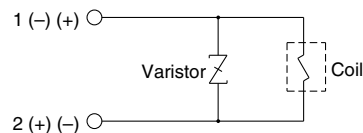

Light / surge voltage suppressor (TZ/DZ)

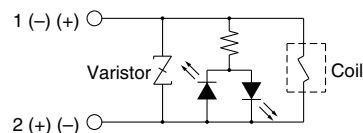

M12 connector (non-polar type)

Surge voltage suppressor (WS)

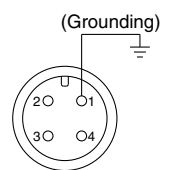
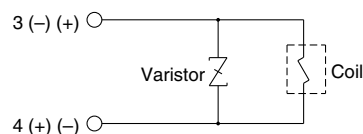

Light / surge voltage suppressor (WZ)

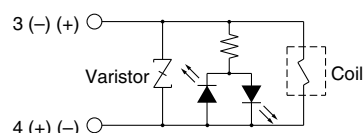



Series SGC

Specific Product Precautions 2

Be sure to read this before handling.

Refer to front matters 42 and 43 for Safety Instructions, and pages 17 to 19 for 2 Port Solenoid Valves for Fluid Control Precautions.

Light / Surge Voltage Suppressor

⚠ Caution

<For AC>

Conduit terminal

Surge voltage suppressor (TS)

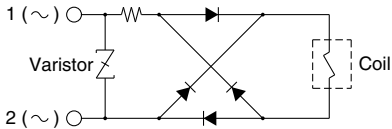

Light / surge voltage suppressor (TZ)

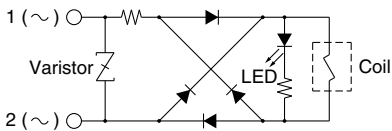

DIN terminal

Surge voltage suppressor (DS)

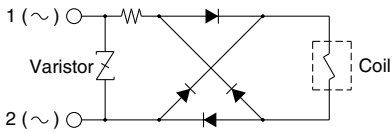

Light / surge voltage suppressor (DZ)

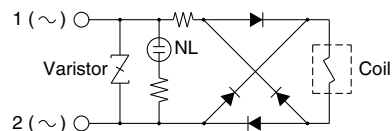

M12 connector

Surge voltage suppressor (WS)

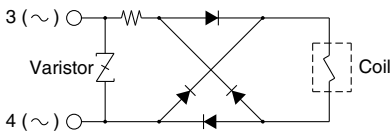

Light / surge voltage suppressor (WZ)

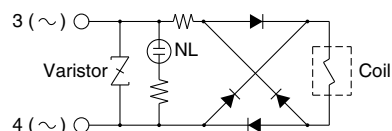

M12 Connector

⚠ Caution

1. M12 connector types have an IP65 (enclosure) rating, offering protection from dust and water. However please note: these products are not intended for use in water.
2. Do not use a tool to mount the connector, as this may cause damage. Only tighten by hand. (0.4 to 0.6 N·m)
3. The excessive stress on the cable connector will not be able to satisfy the IP65 rating. Please use caution and do not apply a stress of 30 N or greater.

Note that if a connector other than the one stated above is used or if the connector is not tight enough, the IP65 standards will not be satisfied.

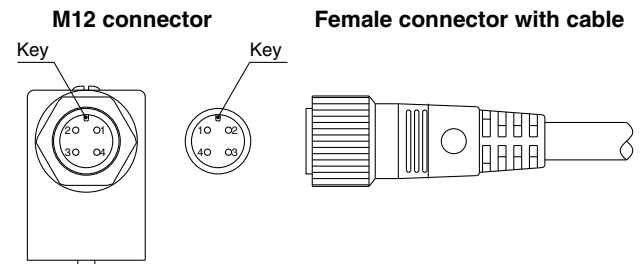

Note) For connecting a female connector with cable, adjust the connector key to the M12 connector key in the valve side since there is an orientation. Be careful not to squeeze it in the wrong direction, as problems such as pin damage may occur.

VNA

VNB

SGC

VNC

VNH

VND

VCC



Series SGC Specific Product Precautions 3

Be sure to read this before handling.

Refer to front matters 42 and 43 for Safety Instructions, and pages 17 to 19 for 2 Port Solenoid Valves for Fluid Control Precautions.

How to Use Conduit Terminal

⚠ Caution

Connection

1. Loosen the holding screw and remove the cover from the terminal block.
2. Loosen the screw in the terminal block. Insert the lead core wires or crimped terminals to the terminals, and secure the wires by re-tightening the terminal screw.
3. Secure the cord by fastening the ground nut.

When making connections, take note that using other than the supported size ($\phi 4.5$ to $\phi 7$) heavy duty cord will not satisfy IP65 (enclosure) standards. Also, be sure to tighten the ground nut and holding screw within their specified torque ranges.

Compatible cable

Cord O.D.: $\phi 4.5$ to $\phi 7$

(Reference) 0.5 to 1.5 mm², 2-core or 3-core, equivalent to JIS C 3306

Applicable crimped terminals

O-terminals: Equivalent to R1.25-3 defined in the JIS C2805

Y-terminals: Equivalent to 1.25-3 manufactured by J.S.T. Mfg. Co., Ltd.

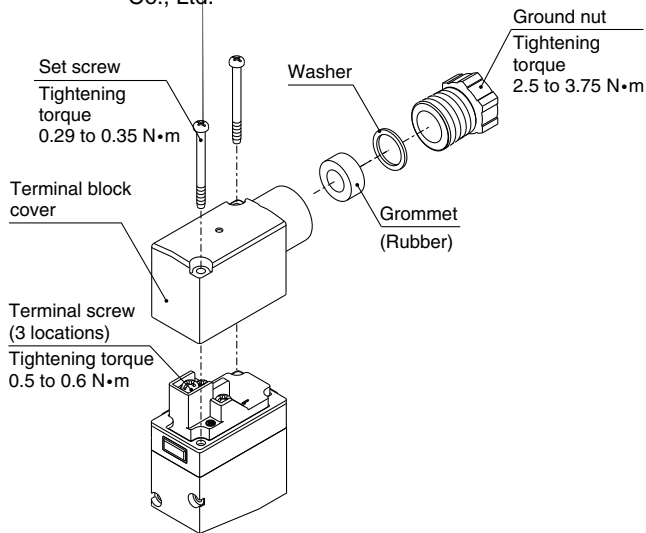

How to Use DIN Terminal

⚠ Caution

Connection

1. Loosen the holding screw and pull the connector out of the solenoid valve terminal block.
2. After removing the holding screw, insert a flat head screwdriver, etc. into the notch on the bottom of the terminal block and pry it open, separating the terminal block and the housing.
3. Loosen the screw (slotted screws) in the terminal block. Insert the lead core wires or crimped terminals to the terminals according to the connection method, and secure the wires by re-tightening the terminal screw.
4. Secure the cord by fastening the ground nut.

When making connections, take note that using other than the supported size ($\phi 4.5$ to $\phi 7$) heavy duty cord will not satisfy IP65 (enclosure) standards. Also, be sure to tighten the ground nut and holding screw within their specified torque ranges.

Changing the entry direction

After separating the terminal block and housing, the cord entry can be changed by attaching the housing in the opposite direction 180°.

* Be careful not to damage the element, etc. with the cord's lead wires.

Plug in and pull out the connector vertically without tilting to one side.

Compatible cable

Cord O.D.: $\phi 4.5$ to $\phi 7$

(Reference) 0.5 to 1.5 mm², 2-core or 3-core, equivalent to JIS C 3306

Applicable crimped terminals

O-terminals: Equivalent to R1.25-4M defined in the JIS C2805

Y-terminals: Equivalent to R1.25-3L manufactured by J.S.T. Mfg. Co., Ltd.

Rod-terminals: Up to size 1.5

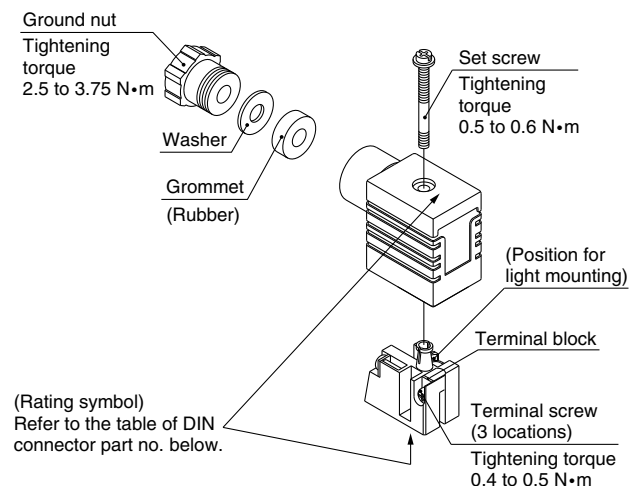



Series SGC

Specific Product Precautions 4

Be sure to read this before handling.

Refer to front matters 42 and 43 for Safety Instructions, and pages 17 to 19 for 2 Port Solenoid Valves for Fluid Control Precautions.

How to Use DIN Terminal

⚠ Caution

DIN Connector Part No.

Without light	DC Spec. only	V100-61-1
---------------	---------------	-----------

With Surge Voltage Suppressor

Rated voltage	Voltage symbol	Model no.
24 VDC	DC 24 VS	V100-61-5-05
12 VDC	DC 12 VS	V100-61-5-06
100 VAC	100/110 VS	V100-61-4-01
200 VAC	200/220 VS	V100-61-4-02
110 VAC	100/110 VS	V100-61-4-01
220 VAC	200/220 VS	V100-61-4-02
240 VAC	240 VS	V100-61-4-07

With Light / Surge Voltage Suppressor

Rated voltage	Voltage symbol	Model no.
24 VDC	DC 24 VZ	V100-61-3-05
12 VDC	DC 12 VZ	V100-61-3-06
100 VAC	100/110 VZ	V100-61-2-01
200 VAC	200/220 VZ	V100-61-2-02
110 VAC	100/110 VZ	V100-61-2-01
220 VAC	200/220 VZ	V100-61-2-02
240 VAC	240 VZ	V100-61-2-07

If an AC specification without DIN Terminal (DO) is selected, always use a DIN connector with surge voltage suppressor as the connector.

Circuit Diagram with Light / Surge Voltage Suppressor

AC circuit diagram

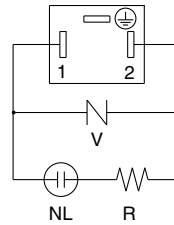

NL: Neon bulb, R: Resister
V: Varistor

DC circuit diagram

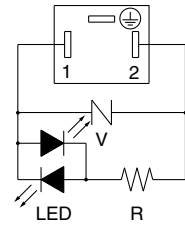

LED: Emitting diode, R: Resister
V: Varistor

Operating Environment

⚠ Caution

Products with IP65 enclosures (based on IEC60529) are protected against dust and water, however, these products cannot be used in water.

VNA

VNB

SGC

VNC

VNH

VND

VCC