

3 Port Solenoid Valve

Series VKF300

Rubber Seal

Direct Operated Poppet Type

Compact yet provides a large flow capacity

Body width 18 mm

Available in vacuum applications (-101.2 kPa)

(Valve leakage: 0.03 cm³/s He or less)
Can be used in vacuum/release circuits

Universal porting

N.C./N.O. type can be switched by supplying air to port 1 (P) or 3 (R). 2 way valves and selector valves can also be freely used.

Ozone resistant (Series 80-)

FKM (Fluoro rubber) is used for the fluid-contact rubber materials, allowing for use even in ozone environments.

Various manifold piping directions

Output port: Manifold set-up allowing 360° rotation of 2 (A) entry direction (in 90° increments)

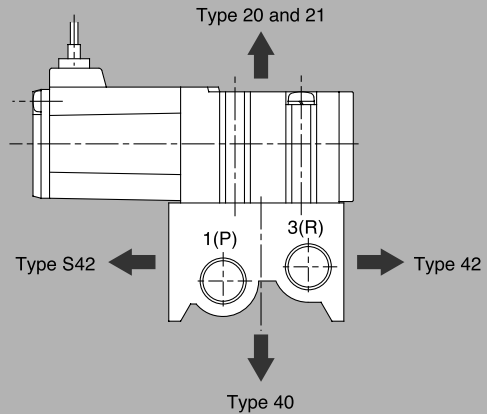

Easy manual operation

Since manual overrides are located in 2 directions, on the top and on the side of the valve, manual override operation is possible and is unaffected by mounting space and piping direction, etc.

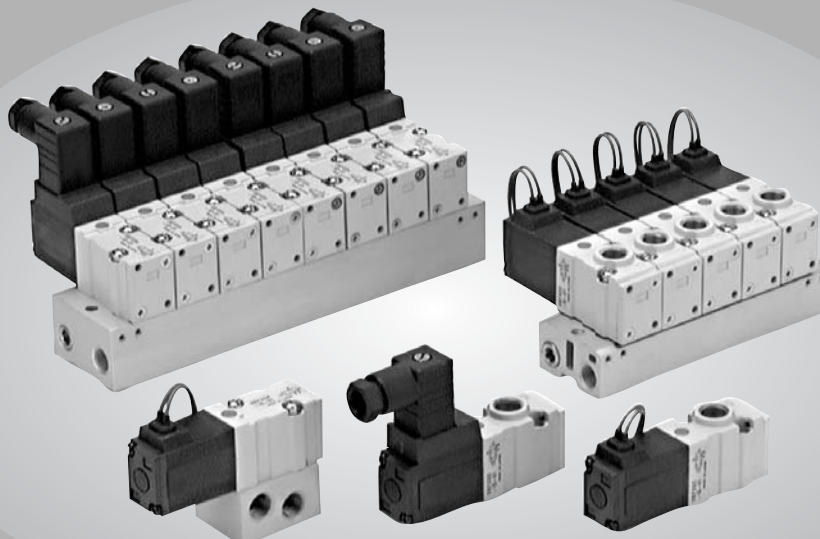
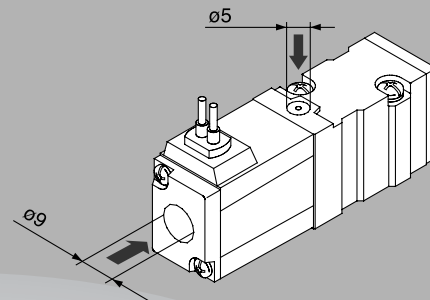

VV061

V100

S070

VQD

VKF

VK

VT

VS

3 Port Solenoid Valve

Direct Operated Poppet Type

Series VKF300



How to Order Valves



Rated voltage

1	100 VAC, 50/60 Hz
2	200 VAC, 50/60 Hz
3*	110 VAC, 50/60 Hz
4*	220 VAC, 50/60 Hz
5	24 VDC
6*	12 VDC
7*	240 VAC, 50/60 Hz
9	Other

* Option

Electrical entry

G: Grommet (Lead wire length: 300 mm)	H: Grommet (Lead wire length: 600 mm)	D: DIN terminal	DO: DIN terminal* (Without connector)
---	---	------------------------	---

Thread type

Nil	RC
F	G
N	NPT
T	NPTF

* For the port size 01 only.

Port size

M5	M5 x 0.8
01	Rc 1/8 (A port)

Body ported (Single type)
VKF332 □ — 5 G □ — M5 □ (With bracket)

Body ported (For manifold)
VKF333 □ — 5 G □ — M5 □

Base mounted
VKF334 □ — 5 G □ — 01 □

Valve option

V	For vacuum
Y*	For low power consumption
W*	For vacuum/low power consumption
E*	Continuous duty type

* Applicable voltage: 12 and 24 VDC

Light/Surge voltage suppressor

Nil	None
S	With surge voltage suppressor
Z	With light/surge voltage suppressor (Type "D" only)

* Since the indicator light is built in the connector, thus, "DOZ" is not available.

Port size

01	Rc 1/8 (With sub-plate)
Nil	Without sub-plate

Flow Characteristics/Mass

Valve model	Operating pressure range (MPa)	Port size	Flow characteristics						Mass (g)		
			1 → 2 (P → A)			2 → 3 (A → R)			Grommet	DIN terminal	
			C [dm ³ /(s·bar)]	b	Cv	C [dm ³ /(s·bar)]	b	Cv			
Body ported	0 to 0.7	M5 x 0.8	VKF332 ³	0.67	0.10	0.15	0.41	0.39	0.11	80 ⁽¹⁾	90 ⁽¹⁾
			VKF332 ³ Y	0.56	0.13	0.13	0.32	0.25	0.09		
			VKF332 ³ E	0.56	0.13	0.13	0.32	0.25	0.09		
			VKF332 ³ V	0.67	0.10	0.15	0.41	0.39	0.11		
			VKF332 ³ W	0.56	0.13	0.13	0.32	0.25	0.09		
Base mounted (With sub-plate)	0 to 0.7	Rc 1/8	VKF334	0.68	0.13	0.15	0.59	0.31	0.14	120	130
			VKF334Y	0.56	0.13	0.13	0.32	0.25	0.09		
			VKF334E	0.56	0.13	0.13	0.32	0.25	0.09		
			VKF334V	0.68	0.13	0.15	0.59	0.31	0.14		
			VKF334W	0.56	0.13	0.13	0.32	0.25	0.09		

Note 1) VKF33□: Add 10 g to each when equipped with bracket.

3 Port Solenoid Valve Direct Operated Poppet Type **Series VKF300**

Standard Specifications



Body ported



Base mounted

JIS Symbol

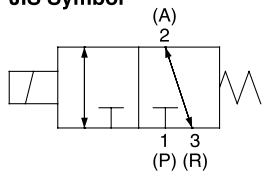

Valve specifications	Type of actuation		Direct operated type 2 position single solenoid
	Fluid		Air
	Ambient and fluid temperature		Max. 50°C
	Response time (at 0.5 MPa) ⁽¹⁾		10 ms or less (Standard), 15 ms or less (Low power consumption type)
	Manual override		Non-locking push type
	Lubrication		Not required (Use turbine oil Class 1 ISO VG32, if lubricated.)
	Mounting orientation		Unrestricted
	Impact/Vibration resistance ⁽²⁾		300/50 m/s ²
Electricity specifications	Enclosure		Dustproof
	Electrical entry		Grommet (G), DIN terminal (D)
	Rated voltage	AC	100, 110, 200, 220, 240 V
		DC	6, 12, 24, 48 V
	Allowable voltage fluctuation		±10% of rated voltage
	Apparent power (AC)	Inrush	9.5 VA/50 Hz, 8 VA/60 Hz
		Holding	7 VA/50 Hz, 5 VA/60 Hz
	Power consumption (DC)	W/o indicator light	4 W (Standard), 2 W (Low power consumption type)
		W/ indicator light	4.3 W (Standard), 2.3 W (Low power consumption type)
	Surge voltage suppressor	AC	Varistor
DC		Diode (Varistor for 12 VDC or less)	
Indicator light	AC	Neon bulb	
	DC	LED	



Note 1) Based on dynamic performance test, JIS B 8374-1981. (Coil temperature: 20°C, at rated voltage, without surge voltage suppressor)

* When equipped with DC solenoid/surge voltage suppressor, a delay of about 20 to 30 m/sec. occurs in the OFF response time.

Note 2) Impact resistance: No malfunction occurred when it is tested with a drop tester in the axial direction and at the right angles to the main valve and armature in both energized and de-energized states every once for each condition. (Values at the initial period)

Vibration resistance: No malfunction occurred in a one-sweep test between 45 and 2000 Hz. Test was performed at both energized and de-energized states in the axial direction and at the right angles to the main valve and armature. (Values at the initial period)

Construction

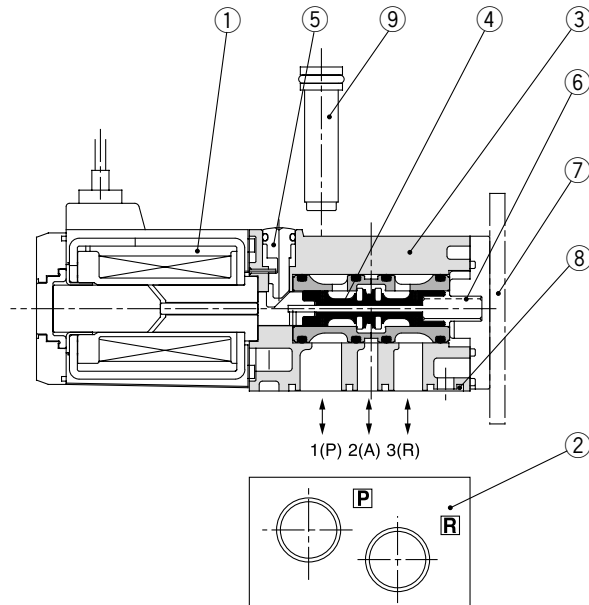

Component Parts

No.	Description	Material	Note
①	Solenoid coil assembly	—	
②	Sub-plate	Aluminum die-casted	For VKF334: VKF300-S-01
③	Body	Aluminum die-casted	
④	Spool/Sleeve	Aluminum	
⑤	Manual override	Resin	
⑥	Return spring	Stainless steel	
⑦	Bracket assembly	Steel	For VKF332: VKF300-13A-2
⑧	Gasket assembly (With mounting screw)	—	For VKF333: VKF300-11A-2 For VKF334: VKF300-11A-1
⑨	Bushing assembly	Resin	For VKF333: VKF300-6A-1 2 sets per unit required

VV061
V100
S070
VQD
VKF
VK
VT
VS

Series VKF300

Dimensions: Single Type

Body ported

Grommet: VKF332□-□G-M5₀₁

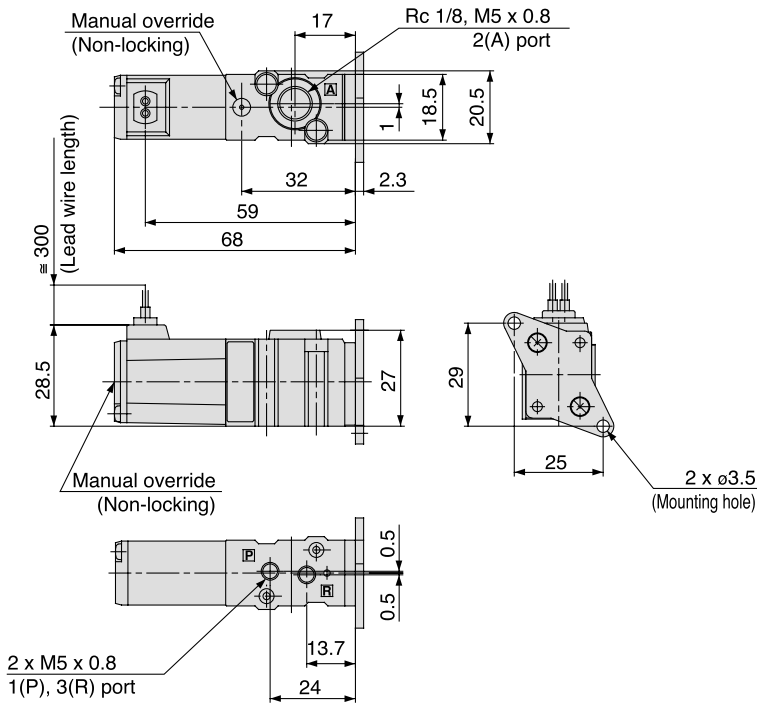

DIN terminal: VKF332□-□D-M5₀₁

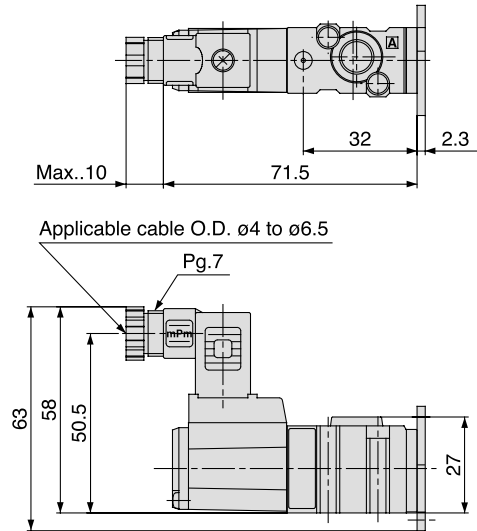

Refer to grommet type for other dimensions.

Base mounted

Grommet: VKF334□-□G-01

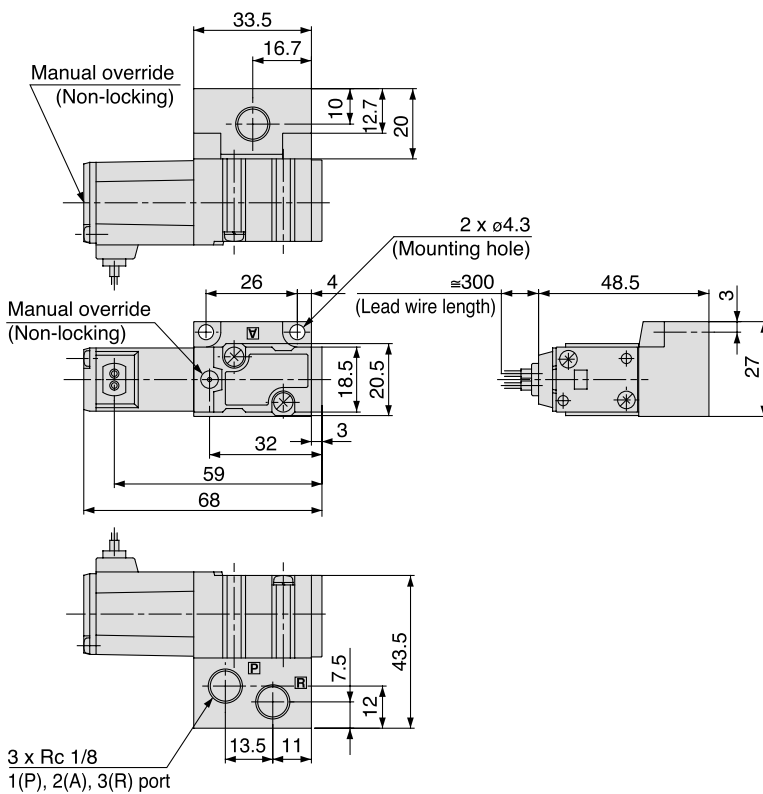

DIN terminal: VKF334□-□D-01

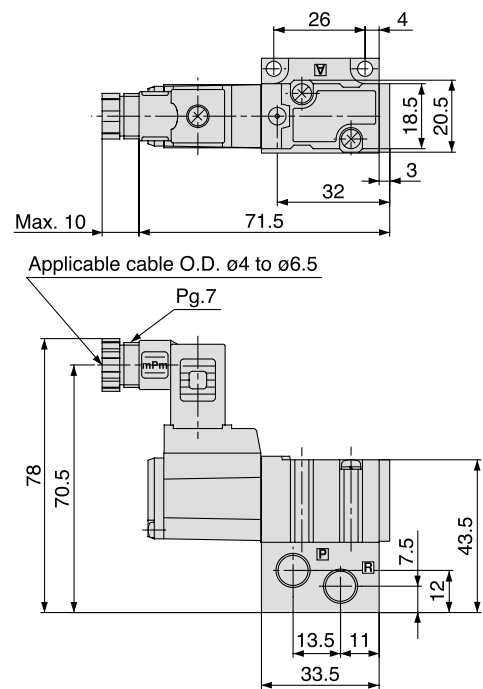

Refer to grommet type for other dimensions.

How to Order Manifold

Body ported

Common SUP/Common EXH

Type 20: Body ported
(A port top ported)

2(A) port:
Rc 1/8, M5 x 0.8

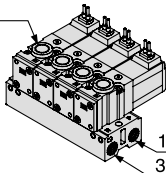

How to Order

VV3KF3 - 20 - 05 - [] - []

Valve stations

01	1 station
⋮	⋮
20	20 stations

Thread type

Nil	Rc
00F	G
00N	NPT
00T	NPTF

Applicable solenoid valve
VKF333□-□□□-M5
VKF333□-□□□-01

Applicable blanking plate assembly
VK300-42-1A

Bracket
VK300-43-1A

Option

Nil	None
F	With bracket (Not mounted)

Common SUP/Individual EXH

Type 21: Body ported
(A port top ported)

2(A) port:
Rc 1/8, M5 x 0.8

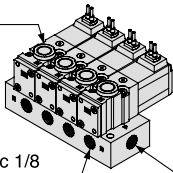

How to Order

VV3KF3 - 21 - 05 - [] - []

Valve stations

01	1 station
⋮	⋮
20	20 stations

Thread type

Nil	Rc
00F	G
00N	NPT
00T	NPTF

Applicable solenoid valve
VKF333□-□□□-M5
VKF333□-□□□-01

Applicable blanking plate assembly
VK300-42-1A

Base mounted

Common SUP/Common EXH

Type 40: Base mounted
(A port bottom ported)

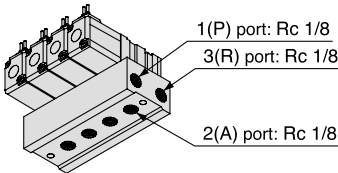

How to Order

VV3KF3 - 40 - 05 - 01 - [] - []

Valve stations

01	1 station
⋮	⋮
20	20 stations

Port size

01	Rc 1/8
----	--------

Thread type

Nil	Rc
F	G
N	NPT
T	NPTF

Applicable solenoid valve
VKF334□-□□□

Applicable blanking plate assembly
VK300-42-1A

Bracket
VK300-43-1A

Option

Nil	None
F	With bracket (Not mounted)

Type 42: Base mounted
(A port side ported)

2(A) port: Rc 1/8
1(P) port: Rc 1/8
3(R) port: Rc 1/8

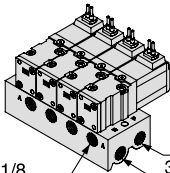

How to Order

VV3KF3 - 42 - 05 - 01 - [] - []

Solenoid direction

Nil	Solenoid on opposite A port
S	Solenoid on same side as A port

Thread type

Nil	Rc
F	G
N	NPT
T	NPTF

Applicable solenoid valve
VKF334□-□□□

Applicable blanking plate assembly
VK300-42-1A

Type S42 (Solenoid on same side as port A)

2(A) port: Rc 1/8
1(P) port: Rc 1/8
3(R) port: Rc 1/8

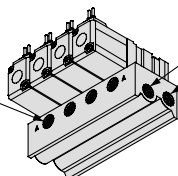

Port size

01	Rc 1/8
C4	ø4 cassette
C6	ø6 cassette

Valve stations

01	1 station
⋮	⋮
20	20 stations

- VV061
- V100
- S070
- VQD
- VKF
- VK
- VT
- VS

Series VKF300

Dimensions: Manifold

Body ported

Type 20 Manifold Common SUP, Common EXH/Top Ported

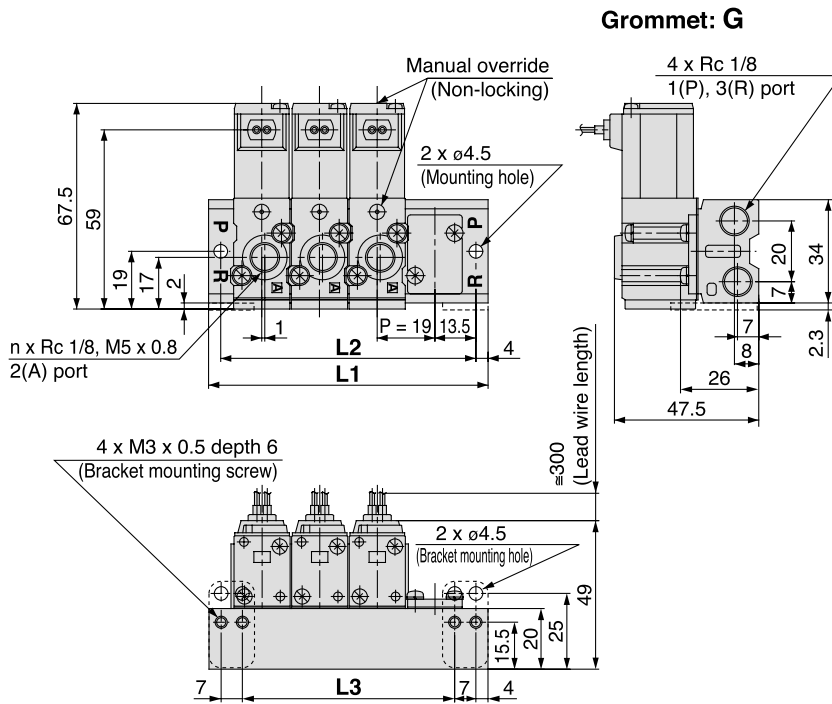

L Dimension

L \ n	1	2	3	4	5	6	7	8	9	10	11	12	13	14	15	16	17	18	19	20
L1	35	54	73	92	111	130	149	168	187	206	225	244	263	282	301	320	339	358	377	396
L2	27	46	65	84	103	122	141	160	179	198	217	236	255	274	293	312	331	350	369	388
L3	13	32	51	70	89	108	127	146	165	184	203	222	241	260	279	298	317	336	355	374

n: Stations

Type 21 Manifold Common SUP, Individual EXH/Top Ported

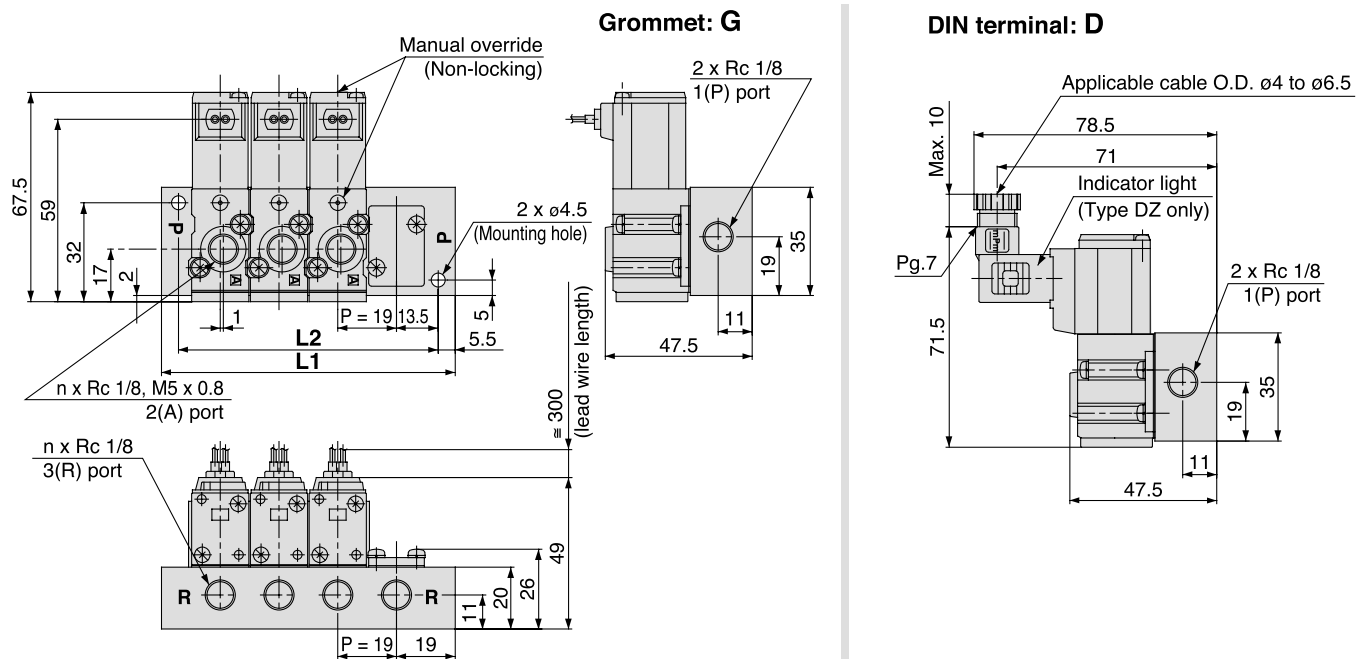

L Dimension

L \ n	1	2	3	4	5	6	7	8	9	10	11	12	13	14	15	16	17	18	19	20
L1	38	57	76	95	114	133	152	171	190	209	228	247	266	285	304	323	342	361	380	399
L2	27	46	65	84	103	122	141	160	179	198	217	236	255	274	293	312	331	350	369	388

n: Stations

3 Port Solenoid Valve Direct Operated Poppet Type **Series VKF300**

Base mounted

Type 40 Manifold Common SUP, Common EXH/Bottom Ported

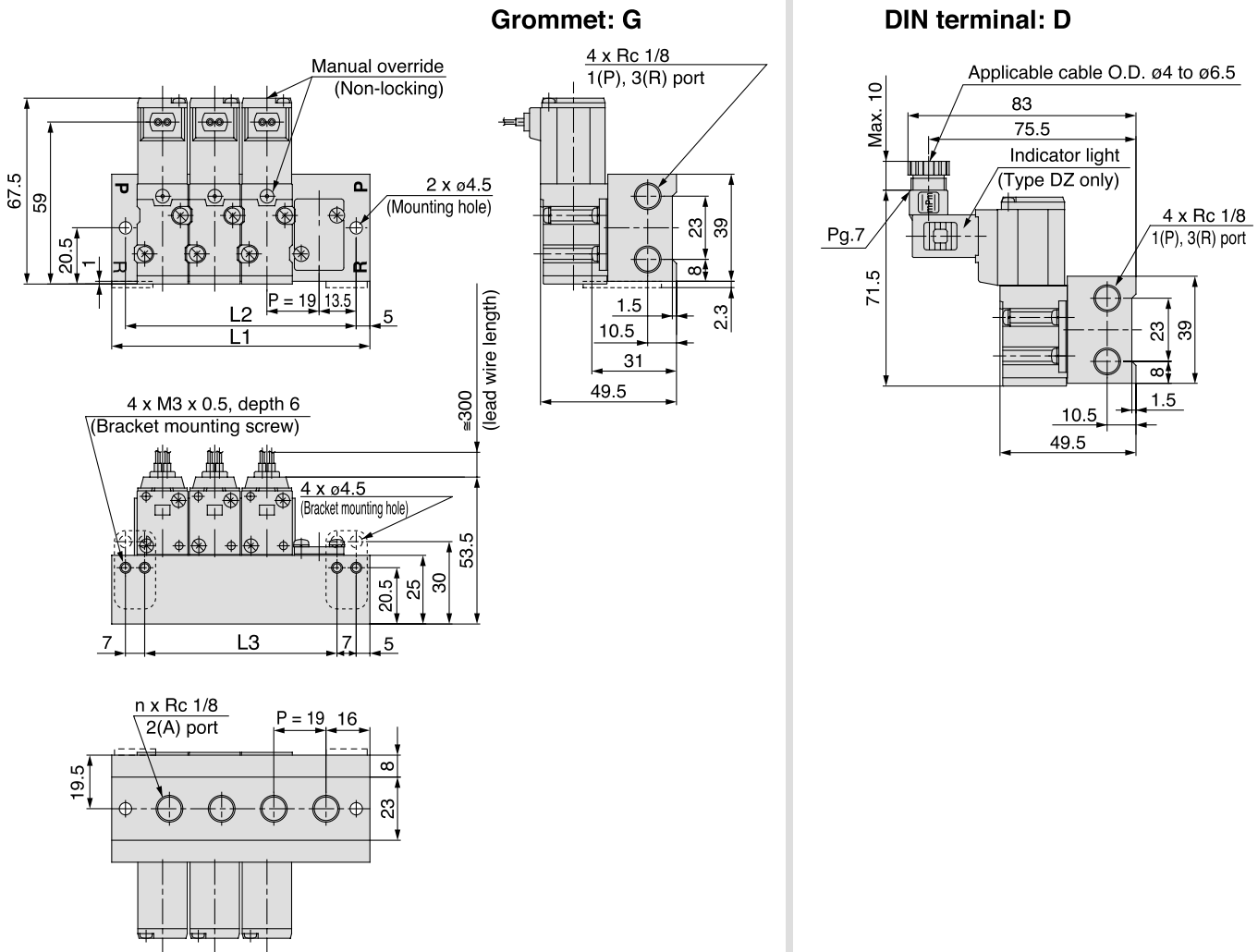

- VV061
- V100
- S070
- VQD
- VKF**
- VK
- VT
- VS

L Dimension

n: Stations

L \ n	1	2	3	4	5	6	7	8	9	10	11	12	13	14	15	16	17	18	19	20
L1	37	56	75	94	113	132	151	170	189	208	227	246	265	284	303	322	341	360	379	398
L2	27	46	65	84	103	122	141	160	179	198	217	236	255	274	293	312	331	350	369	388
L3	13	32	51	70	89	108	127	146	165	184	203	222	241	260	279	298	317	336	355	374

Series VKF300

Dimensions: Manifold

Base mounted

Type 42 Manifold Common SUP, Common EXH/Side Ported

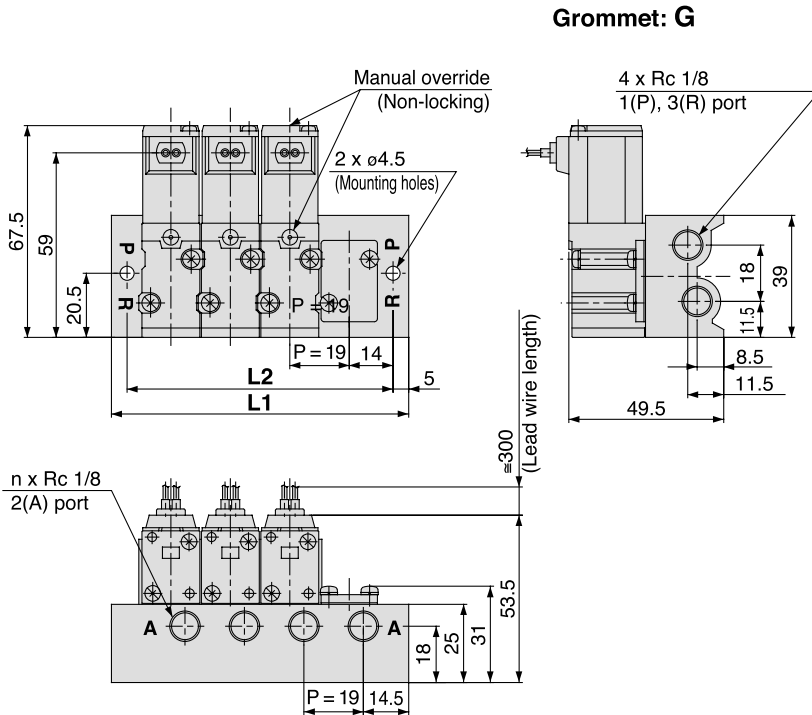

Type S42 Manifold Common SUP, Common EXH/Side Ported: Same direction as solenoid

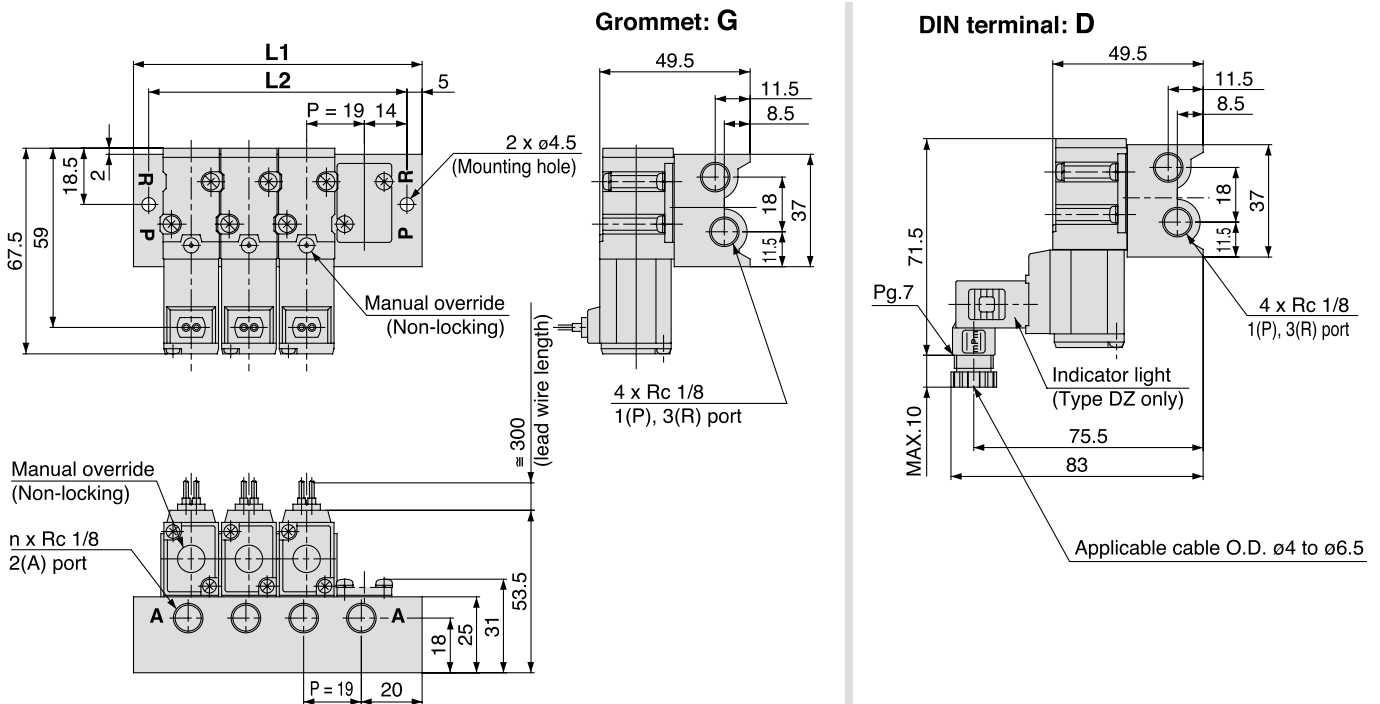

L Dimension

n	1	2	3	4	5	6	7	8	9	10	11	12	13	14	15	16	17	18	19	20
L1	38	57	76	95	114	133	152	171	190	209	228	247	266	285	304	323	342	361	380	399
L2	28	47	66	85	104	123	142	161	180	199	218	237	256	275	294	313	332	351	370	389

n: Stations



Series VKF300 Specific Product Precautions 1

Be sure to read before handling. Refer to front matters 58 and 59 for Safety Instructions and pages 3 to 7 for 3/4/5 Port Solenoid Valve Precautions.

Manual Override Operation

Warning

Connected actuator is started by manual operation. Use the manual override after confirming that there is no danger.

■ Non-locking push type (Tool required)

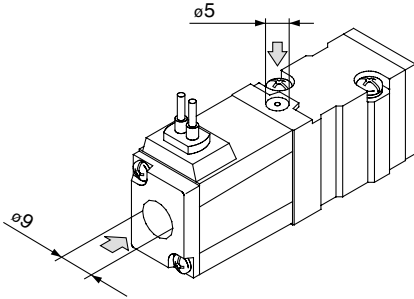

There are manual overrides in 2 directions, on the top and on the side (solenoid side). By pressing either of the manual overrides in the direction of the arrow (R) until it stops (approx. 1 mm), it will turn ON, and it turns OFF when released.

Mounting of Valves

Caution

After confirming the gasket is correctly placed under the valve, securely tighten the bolts with the proper torque shown in the table below.

Proper tightening torque (N·m)
0.6 to 0.8

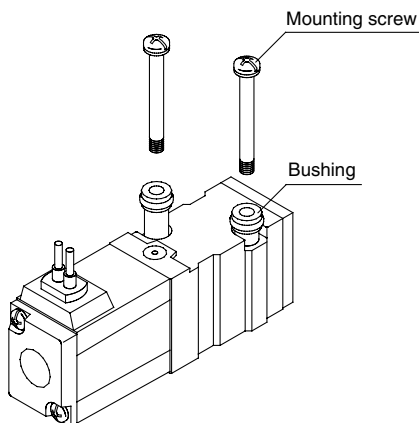

The bushing may be damaged if the tightening torque of 0.8 N·m is exceeded. In the event that damage does occur, be sure to replace the bushing.

SUP Block bushing assembly no.	VKF300-6A-1
--------------------------------	--------------------

- 2 sets per unit are required.

Light/Surge Voltage Suppressor

Caution

		Grommet type (G)	DIN terminal type (D)	Symbol
AC	Without indicator light		No.1 ⊕ No.2 ⊖ 	S
	With indicator light	None	No.1 ⊕ Neon bulb No.2 ⊖ 	Z
12 VDC or less	Without indicator light		No.1 ⊕ No.2 ⊖ 	S
	With indicator light	None	No.1 ⊕ LED No.2 ⊖ 	Z
24 VDC or more	Without indicator light		No.1 ⊕ No.2 ⊖ 	S
	With indicator light	None	No.1 ⊕ LED No.2 ⊖ 	Z

Precautions on connection of 24 V or more DC

For the grommet type, connect the positive (+) side to the red lead wire and connect the negative (-) side to the black lead wire. For the DIN terminal, connect the positive (+) side to the connector's no.1 terminal and connect the negative (-) side to the no.2 terminal. (See the markings on the terminal block.)
* For 12 V or less DC, positive (+) and negative (-) can be connected in either direction.

● Grommet type

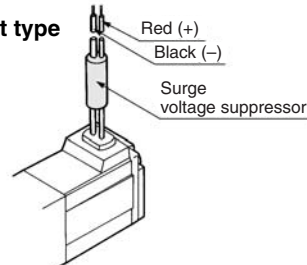

● DIN terminal type

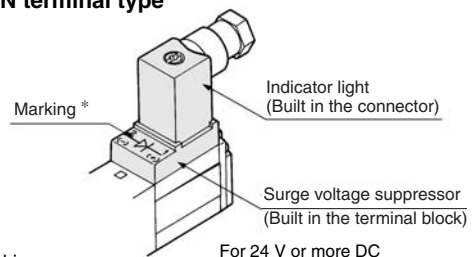

* Marking

For AC and 12 V or less DC



VV061

V100

S070

VQD

VKF

VK

VT

VS



Series VKF300 Specific Product Precautions 2

Be sure to read before handling. Refer to front matters 58 and 59 for Safety Instructions and pages 3 to 7 for 3/4/5 Port Solenoid Valve Precautions.

How to Wire DIN Terminal

Warning

• Connection

1. Loosen the set screw and pull out the connector from the terminal block of the solenoid.
2. After removing the holding screw, insert a flat head screwdriver, etc. into the notch on the bottom of the terminal block and pry it up, separating the terminal block and the housing.
3. Loosen the terminal screws (slotted screws) on the terminal block, insert the core of the lead wire into the terminal in accordance with the prescribed connection method, and attach securely with the terminal screws.
4. Tighten the ground nut to secure the wire.

• Change of electrical entry (Orientation)

After separating terminal block and housing, the cord entry direction can be changed by attaching the housing in the desired direction (4 directions in 90 increments).

*In the case of indicator light, avoid damaging the light with lead wire.

• Precautions

The connector should be inserted and pulled out in a straight line without tilting diagonally.

• Applicable cable

O.D.: $\phi 4$ to $\phi 6.5$

(Reference)

0.5 mm² 2 core and 3 core wires equivalent to JIS C 3306

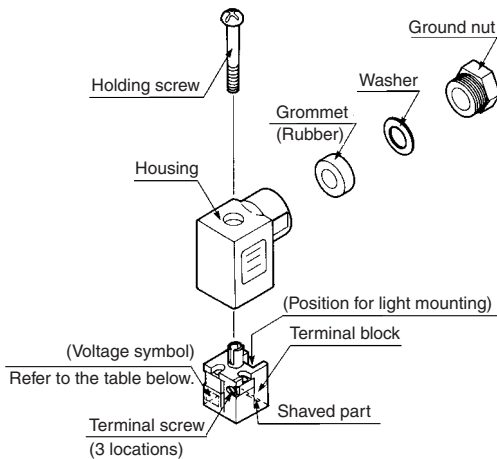

• Connector part no. VK300-82-1

• Part no. for connector with indicator light

Rated voltage	Voltage symbol	Part no.
100 VAC	A1	VK300-82-2-01
200 VAC	A2	VK300-82-2-02
24 VAC	A3	VK300-82-2-07
6 VDC	LW06	VK300-82-4-51
12 VDC	LW2	VK300-82-4-06
24 VDC	LD4	VK300-82-3-05
48 VDC	LD8	VK300-82-3-53

• Circuit with indicator light

AC
Circuit diagram

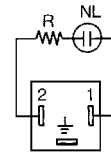

NL: Neon bulb
R: Resistor

12 VDC or less
Circuit diagram

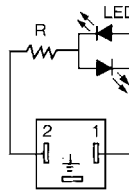

LED: Light emitting diode
R: Resistor

24 VDC or more
Circuit diagram

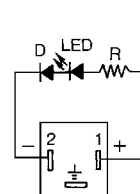

D: Protective diode
LED: Light emitting diode
R: Resistor

How to Calculate the Flow Rate

For obtaining the flow rate, refer to front matters 44 to 47.



3 Way Direct Acting

NVKF 300 Series

Rubber Seal Solenoid Valve

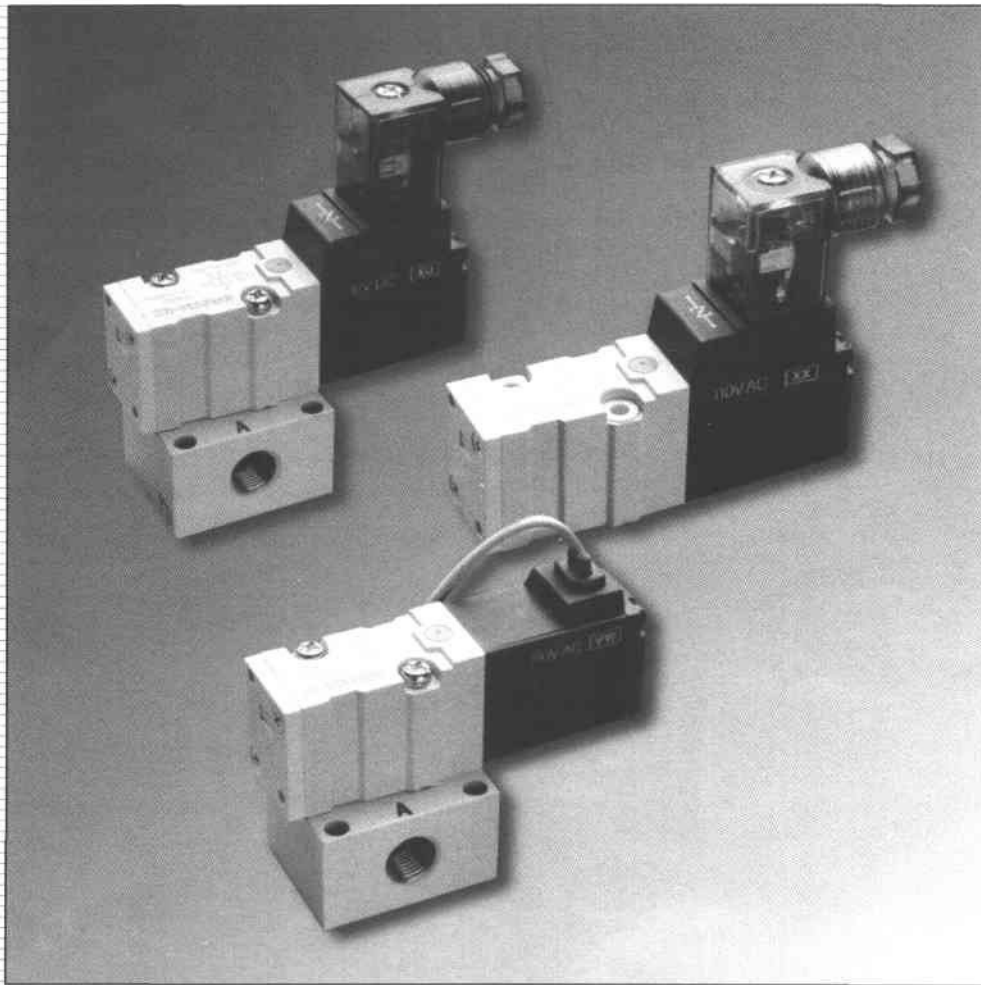

Compact Size / Large Flow Capacity - Cv 0.25
Low Power Option Available
Vacuum Option Available
Base Mounted or Body Ported

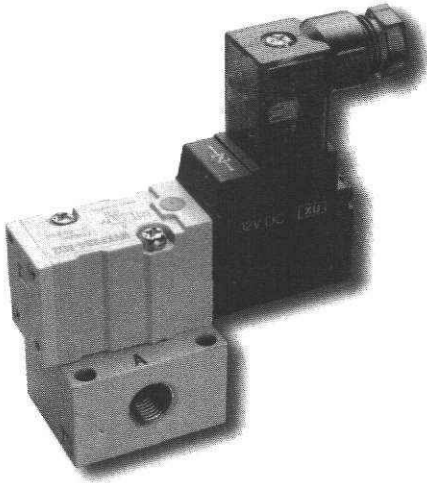

- Large Flow Capacity - Cv 0.25
- Compact Size - width 0.73" × length 2.67"
- Low Power Consumption
4WDC (Standard model)
2WDC (Low wattage model)
- Vacuum Application Possible
- High Speed Response (10ms)

Model

Body Style	Model	Action	Operating pressure range	Port size	Cv factor	Weight	
Body ported (with bracket)	NVKF332	2 position single solenoid	0~100 PSI (0~0.7 MPa)	10-32 Nom. (M5)	0.2	0.181 lbs (80 gf)	
	NVKF332Y (Low wattage: 2WDC)				0.15		
	NVKF332V (Vacuum)		1 Torr~100 PSI (-100 KPa~0.7 MPa)		0.2		
	NVKF332W (Low wattage + Vacuum)				0.15		
Body ported (for manifold)	NVKF333		0~100 PSI (0~0.7 MPa)				0.2
	NVKF333Y (Low wattage: 2WDC)				0.15		
	NVKF333V (Vacuum)		1 Torr~100 PSI (-100 KPa~0.7 MPa)				0.2
	NVKF333W (Low wattage + Vacuum)				0.15		
Base mounted	NVKF334	0~100 PSI (0~0.7 MPa)	1/8 NPTF	0.25	0.271 lbs (120 gf)		
	NVKF334Y (Low wattage: 2WDC)			0.15			
	NVKF334V (Vacuum)	1 Torr~100 PSI (-100 KPa~0.7 MPa)				0.25	
	NVKF334W (Low wattage + Vacuum)			0.15			

Specifications

Model	Direct operated 2 position single solenoid
Structure	Poppet valve
Fluid	Air or Inert gas
Operating pressure range	0~100 PSI (0~0.7 MPa)
Ambient and fluid temperature	Max. 120°F (50°C)
* Response time	10ms or less (Std.) (Y, W types: 15ms)
Max. operating frequency	600 cpm
Manual override	Non-locking push type
Lubrication	Not required
Mounting position	Free
Impact / vibration resistance	30G / 5G (83~2000Hz)
Protection structure	Dust proof

* At rated voltage and without light surge voltage suppressor.

Solenoid Specifications

Electrical entry		Grommet (G), DIN Connector (D)		
Rated voltage *	AC	110V ^{50/60} HZ, 220V ^{50/60} HZ, 100V ^{50/60} HZ, 200V ^{50/60} HZ		
	DC	12V, 24V		
Allowance voltage range		±10% rated voltage		
Coil insulation		Class B or equivalent		
* Temperature rise		130°F or less (Standard) 95°F or less (Low power consumption)		
* Apparent power	AC	Standard	Inrush Holding	8VA / 60Hz, 9.5VA / 50Hz 5VA / 60Hz, 7VA / 50Hz
		Continuous duty	Inrush Holding	3.3VA / 60Hz, 3.5VA / 50Hz 2.8VA / 60Hz, 3VA / 50Hz
* Power consumption	DC	Without light		4W (Standard), 2W (Low power consumption Y, W types)
		With light		4.3W (Standard), 2.3W (Low power consumption Y, W types)
Surge voltage suppressor		AC: Resistor DC: Diode		
Indicator light		AC: Neon lamp DC: LED		

* When applied at rated voltage.

* Contact SMC for availability.

*** Voltage**

3	110VAC ^{50/60} Hz
4	220VAC ^{50/60} Hz
5	24VDC
6	12VDC
*9	Others ^{Note1)}

* Special order
 Note1) Indicate in parentheses at end of part #
 Ex. (AC24V)

Electrical entry

- G** Grommet
Lead wire length: 12inch (300mm)
- D** DIN connector

* (H) Grommet type with 24 inch leads is also available. Special order only.

Port size

M5	10-32 Nom. (M5)
01T	1/8 NPTF (A port only)

Part no. of option

Description	Part no.	Note
Bracket	VKF300-13A-1	With screw
Manifold gasket	VKF300-11A-2	Body ported With screw
	VKF300-11A-1	Base mounted With screw

Body ported

NVKF332 ○ — **5 G** ○ — **M5** (With bracket)

Body ported

NVKF333 ○ — **5 G** ○ — **M5** (Manifold only)

Base mounted

NVKF334 ○ — **5 G** ○ — **01T**

Valve option

- (Standard)
- V** Vacuum

***Y** Low power consumption

***W** Vacuum· Low power consumption

* Special order

Port size

- Without subplate
- 01T** 1/8 NPTF subplate

Indicator light / Surge voltage suppressor

- None
- ***S** With surge voltage suppressor
- Z** With indicator light and surge voltage suppressor (D type only)

* Z option is not available with grommet.

* Special order

Construction / Parts List

Symbol

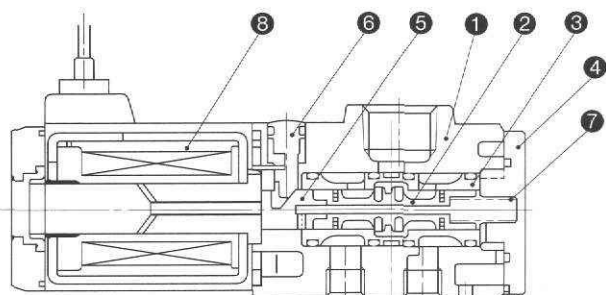
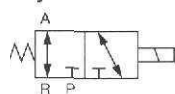

Main Parts

No.	Description	Material	Note
1	Body	Aluminum	
2	Spool valve ass'y		
3	Sleeve ass'y		
4	End plate	Resin	
5	Manual guide	Resin	
6	Manual override ass'y		
7	Return spring	Stainless steel	
8	Coil ass'y		

Series NVKF300 Manifold

Specifications

Valve stations	2~20 stations (max.)	
Manifold	Common SUP. Common EXH.	Body ported, Base mounted
	Common SUP. Individual EXH.	Body ported

How to Order Manifold

Common Supply, Common Exhaust

Body ported / Type 20
(A port: top porting)

NVV3KF3-20-05-00T-

Stations		Optional accessory	
02	2 stations	-	None
⋮	⋮		
20	20 stations	F	With bracket (Not mounted)

Applicable valves
NVKF333○-○○○-M5
NVKF333○-○○○-01T

Applicable blank plate ass'y
VK300-42-1A
Bracket
VK300-43-1A

Base mounted / Type 40
(A port: bottom porting)

NVV3KF3-40-05-01T-

Stations		Optional accessory	
02	2 stations	-	None
⋮	⋮		
20	20 stations	F	With bracket (Not mounted)

Port size	
01T	1/8 NPTF

Applicable valves
NVKF334○-○○○

Applicable blank plate ass'y
VK300-42-1A

Bracket
VK300-43-1A

Base mounted / Type 42
(A port: side porting)

NVV3KF3-○42-05-01T

Position of solenoid		Stations	
-	Opposite side of A port	02	2 stations
⋮	⋮	⋮	⋮
S	Same side as A port	20	20 stations

Port size	
01T	1/8 NPTF
B3T	One touch fitting for 5/32" tube
B7T	One touch fitting for 1/4" tube

Applicable valves
NVKF334○-○○○

Applicable blank plate ass'y
VK300-42-1A

Common Supply, Individual Exhaust

Body ported / Type 21
(A port: top porting)

NVV3KF3-21-05-00T

Stations	
02	2 stations
⋮	⋮
20	20 stations

Applicable valves
NVKF333○-○○○-M5
NVKF333○-○○○-01T

Applicable blank plate ass'y
VK300-42-1A

3 Body Ported

inch (mm)

Ørommet (G): NVKF332-*G-M5

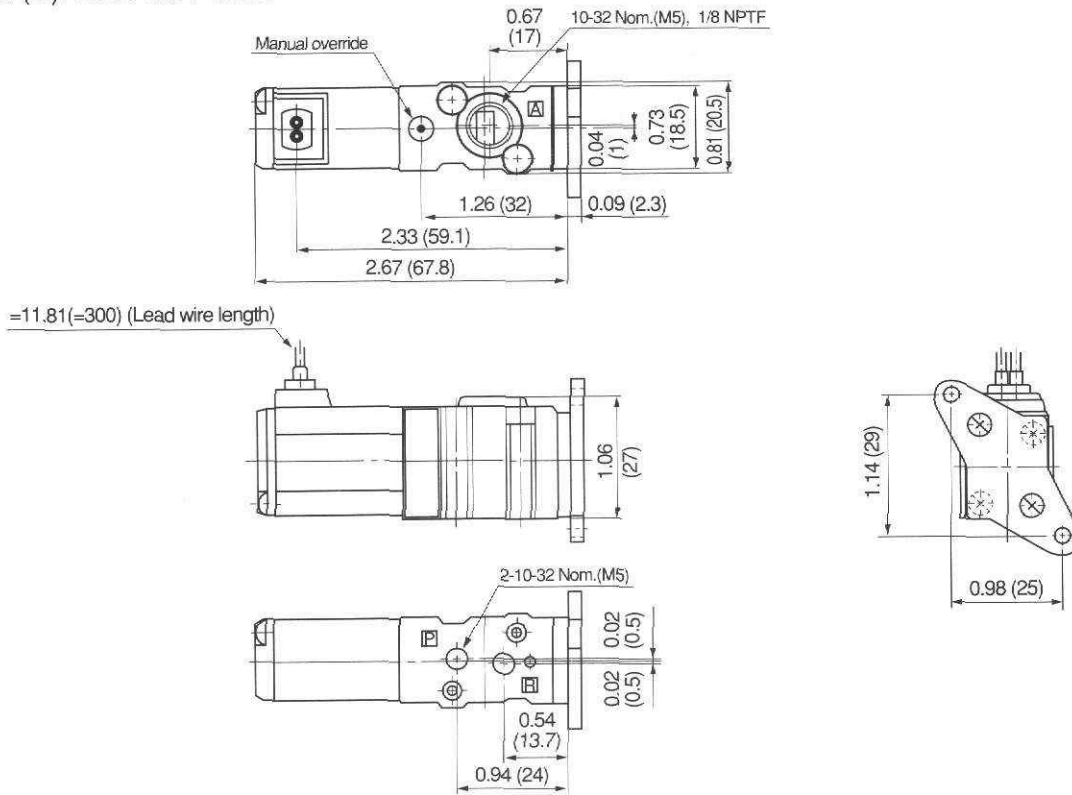

3 Base Mounted

inch (mm)

Ørommet (G): NVKF334-*G-01T

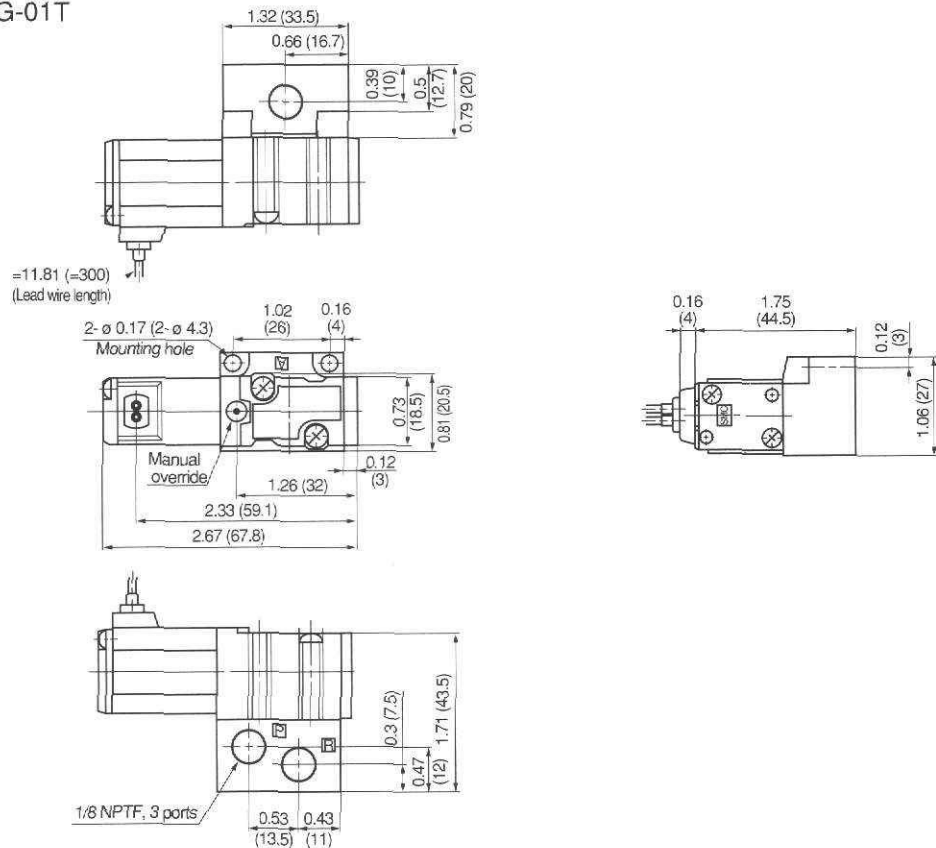

Body Ported (Top Ported) / Type 20 Manifold

NVV3KF3-20-Stations-00T

inch (mm)

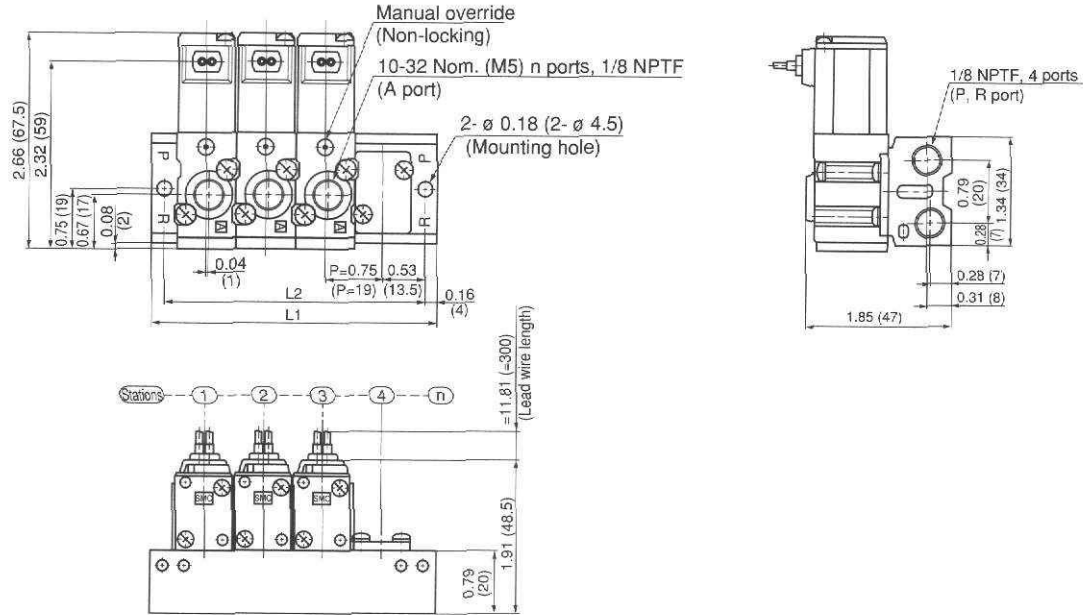

L: Dimensions

n: Stations

L \ n	1	2	3	4	5	6	7	8	9	10	11	12	13	14	15	16	17	18	19	20
L1	1.38 (35)	2.13 (54)	2.87 (73)	3.62 (92)	4.37 (111)	5.12 (130)	5.87 (149)	6.61 (168)	7.36 (187)	8.11 (206)	8.86 (225)	9.61 (244)	10.35 (263)	11.1 (282)	11.85 (301)	12.6 (320)	13.35 (339)	14.09 (358)	14.84 (377)	15.59 (396)
L2	1.06 (27)	1.81 (46)	2.56 (65)	3.31 (84)	4.06 (103)	4.8 (122)	5.55 (141)	6.3 (160)	7.05 (179)	7.8 (198)	8.54 (217)	9.29 (236)	10.04 (255)	10.79 (274)	11.54 (293)	12.28 (312)	13.03 (331)	13.78 (350)	14.53 (369)	15.28 (388)

Body Ported (Top Ported) / Type 21 Manifold

NVV3KF3-21-Stations-00T

inch (mm)

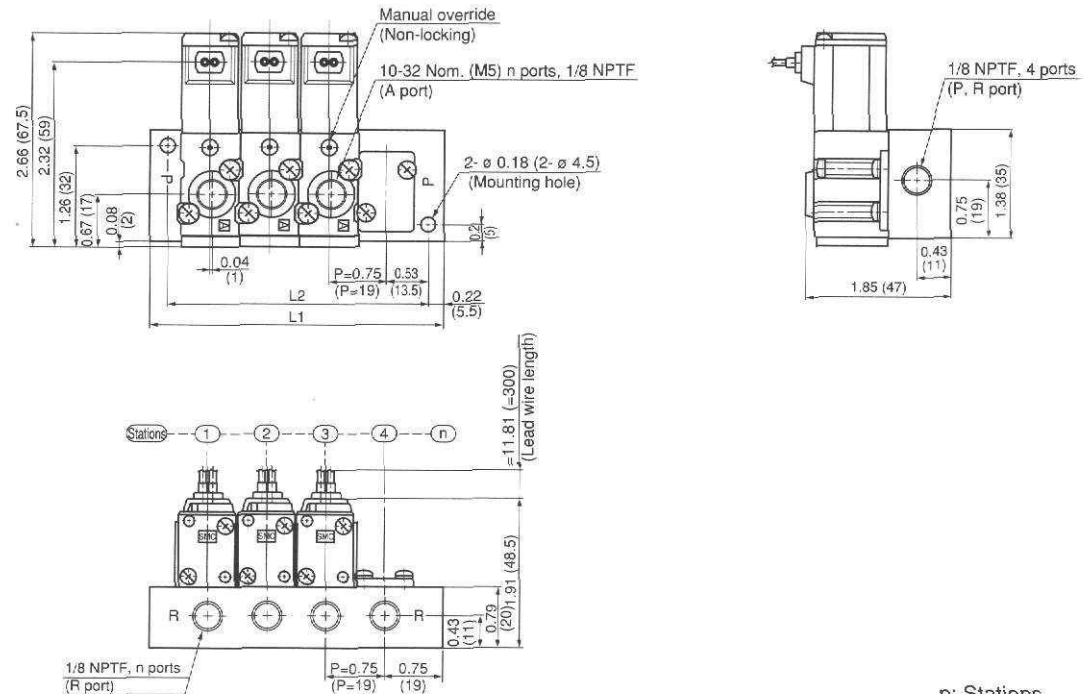

L: Dimensions

n: Stations

L \ n	1	2	3	4	5	6	7	8	9	10	11	12	13	14	15	16	17	18	19	20
L1	1.5 (38)	2.24 (57)	2.99 (76)	3.74 (95)	4.49 (114)	5.24 (133)	5.98 (152)	6.73 (171)	7.48 (190)	8.23 (209)	8.98 (228)	9.72 (247)	10.47 (266)	11.22 (285)	11.97 (304)	12.72 (323)	13.46 (342)	14.21 (361)	14.96 (380)	15.71 (399)
L2	1.06 (27)	1.81 (46)	2.56 (65)	3.31 (84)	4.06 (103)	4.8 (122)	5.55 (141)	6.3 (160)	7.05 (179)	7.8 (198)	8.54 (217)	9.29 (236)	10.04 (255)	10.79 (274)	11.54 (293)	12.28 (312)	13.03 (331)	13.78 (350)	14.53 (369)	15.28 (388)

3ase Mounted (Bottom Ported) / Type 40 Manifold
JVV3KF3-40-Stations-01T

inch (mm)

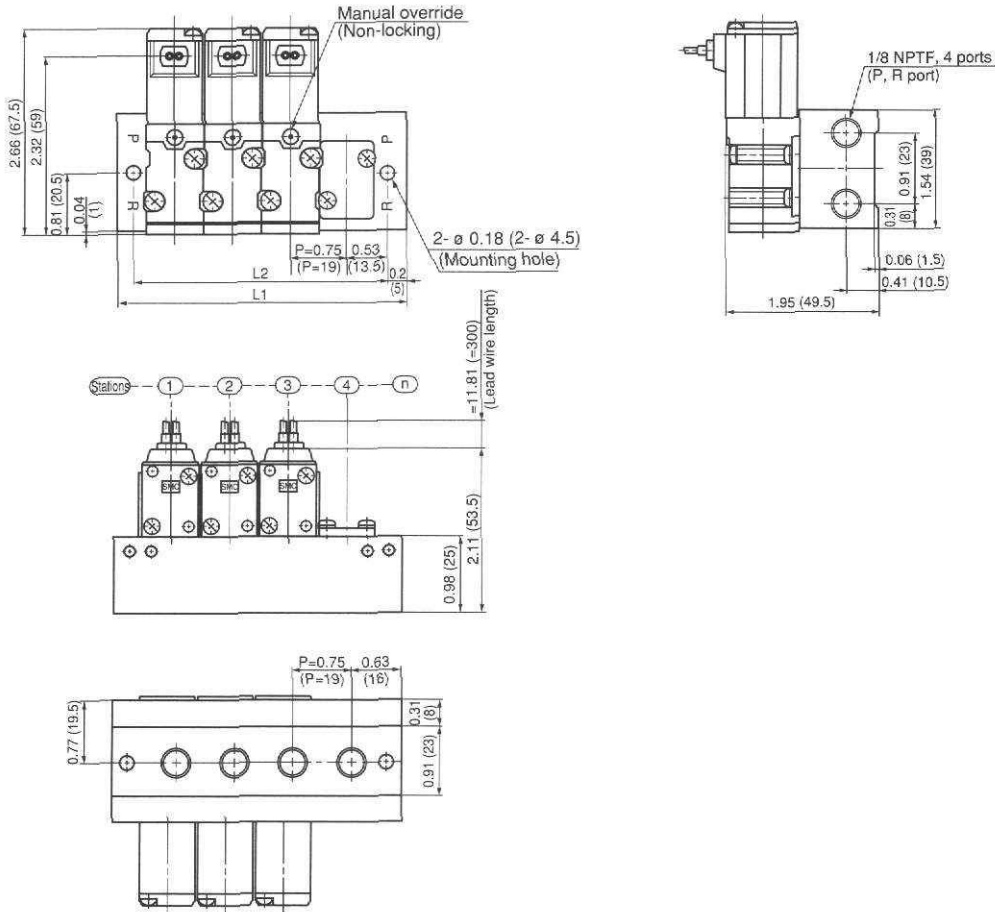

L: Dimensions

n: Stations

L \ n	1	2	3	4	5	6	7	8	9	10	11	12	13	14	15	16	17	18	19	20
L1	1.46 (37)	2.20 (56)	2.95 (75)	3.7 (94)	4.45 (113)	5.2 (132)	5.94 (151)	6.7 (170)	7.44 (189)	8.19 (208)	8.94 (227)	9.69 (246)	10.43 (265)	11.18 (284)	11.93 (303)	12.68 (322)	13.43 (341)	14.17 (360)	14.92 (379)	15.67 (398)
L2	1.06 (27)	1.81 (46)	2.56 (65)	3.31 (84)	4.06 (103)	4.8 (122)	5.55 (141)	6.3 (160)	7.04 (179)	7.8 (198)	8.54 (217)	9.3 (236)	10.04 (255)	10.79 (274)	11.54 (293)	12.28 (312)	13.03 (331)	13.78 (350)	14.53 (369)	15.28 (388)

Base Mounted (Side Ported) / Type 42 Manifold

NVV3KF3-42-Stations-01T

inch (mm)

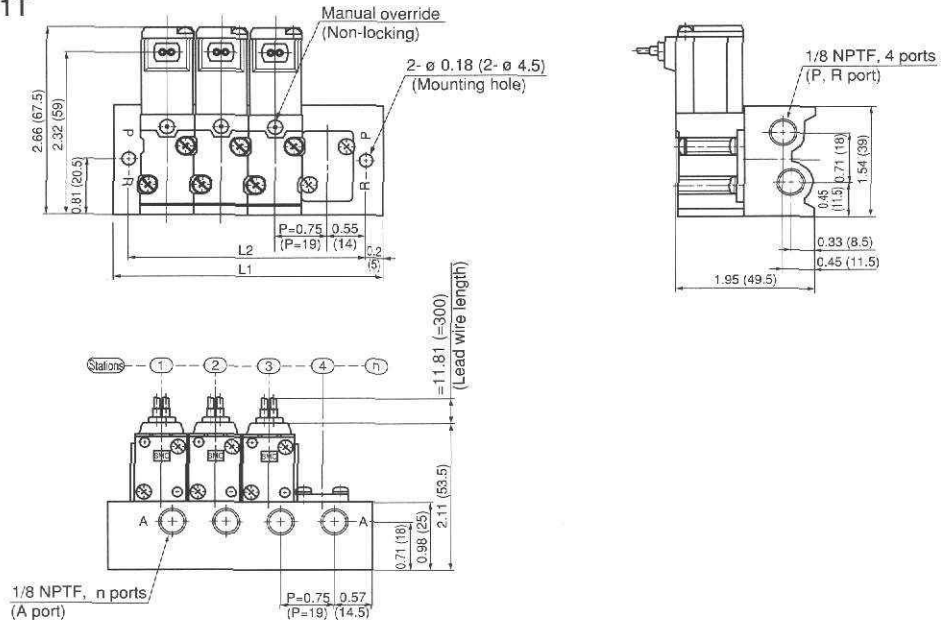

L: Dimensions

L \ n	n: Stations																			
	1	2	3	4	5	6	7	8	9	10	11	12	13	14	15	16	17	18	19	20
L1	1.5 (38)	2.24 (57)	2.99 (76)	3.74 (95)	4.49 (114)	5.24 (133)	5.98 (152)	6.73 (171)	7.48 (190)	8.23 (209)	8.98 (228)	9.72 (247)	10.47 (266)	11.22 (285)	11.97 (304)	12.72 (323)	13.46 (342)	14.21 (361)	14.96 (380)	15.71 (399)
L2	1.1 (28)	1.85 (47)	2.6 (66)	3.35 (85)	4.09 (104)	4.84 (123)	5.59 (142)	6.34 (161)	7.09 (180)	7.83 (199)	8.58 (218)	9.33 (237)	10.08 (256)	10.83 (275)	11.57 (294)	12.32 (313)	13.07 (332)	13.82 (351)	14.57 (370)	15.31 (389)

Base Mounted (Side Ported) / Type S42 Manifold

NVV3KF3-S42-Stations-01T

inch (mm)

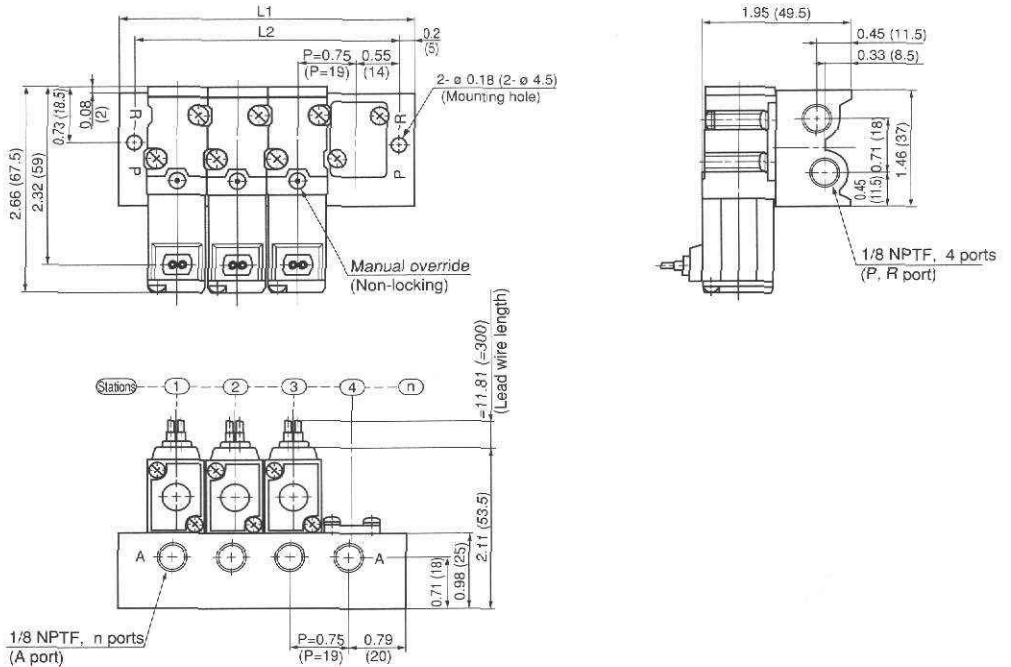

L: Dimensions

L \ n	n: Stations																			
	1	2	3	4	5	6	7	8	9	10	11	12	13	14	15	16	17	18	19	20
L1	1.5 (38)	2.24 (57)	2.99 (76)	3.74 (95)	4.49 (114)	5.24 (133)	5.98 (152)	6.73 (171)	7.48 (190)	8.23 (209)	8.98 (228)	9.72 (247)	10.47 (266)	11.22 (285)	11.97 (304)	12.72 (323)	13.46 (342)	14.21 (361)	14.96 (380)	15.71 (399)
L2	1.1 (28)	1.85 (47)	2.6 (66)	3.35 (85)	4.09 (104)	4.84 (123)	5.59 (142)	6.34 (161)	7.09 (180)	7.83 (199)	8.58 (218)	9.33 (237)	10.08 (256)	10.83 (275)	11.57 (294)	12.32 (313)	13.07 (332)	13.82 (351)	14.57 (370)	15.31 (389)

World Wide SMC Support...

North American Branch Offices For a branch office near you call: 1-800-SMC-SMC1 (762-7621)

SMC Pneumatics Inc. (Atlanta)
1440 Lakes Parkway, Suite 600
Lawrenceville, GA 30043
Tel: (770) 624-1940
FAX: (770) 624-1943

SMC Pneumatics Inc. (Cleveland)
2305 East Aurora Rd., Unit A-3
Twinsburg, OH 44087
Tel: (330) 963-2727
FAX: (330) 963-2730

SMC Pneumatics Inc. (Milwaukee)
16850 W. Victor Road
New Berlin, WI 53151
Tel: (414) 827-0080
FAX: (414) 827-0092

SMC Pneumatics Inc. (Richmond)
5377 Glen Alden Drive
Richmond, VA 23231
Tel: (804) 222-2762
FAX: (804) 222-5221

SMC Pneumatics Inc. (Austin)
2324-D Ridgpoint Drive
Austin, TX 78754
Tel: (512) 926-2646
FAX: (512) 926-7055

SMC Pneumatics Inc. (Columbus)
3687 Corporate Drive
Columbus, OH 43231
Tel: (614) 895-9765
FAX: (614) 895-9780

SMC Pneumatics Inc. (Mnpls.)
990 Lone Oak Road, Suite 162
Eagan, MN 55121
Tel: (651) 688-3490
FAX: (651) 688-9013

SMC Pneumatics Inc. (Rochester)
245 Summit Point Drive
Henrietta, NY 14467
Tel: (716) 321-1300
FAX: (716) 321-1865

SMC Pneumatics Inc. (Boston)
Zero Centennial Drive
Peabody, MA 01960
Tel: (978) 326-3600
Fax: (978) 326-3700

SMC Pneumatics Inc. (Dallas)
12801 N. Stemmons Frwy, Ste. 815
Dallas, TX 75234
Tel: (972) 406-0082
FAX: (972) 406-9904

SMC Pneumatics Inc. (Nashville)
5000 Linbar Drive, Suite 297
Nashville, TN 37211
Tel: (615) 331-0020
FAX: (615) 331-9950

SMC Pneumatics Inc. (S.F.)
85 Nicholson Lane
San Jose, CA 95134
Tel: (408) 943-9600
FAX: (408) 943-9111

SMC Pneumatics Inc. (Charlotte)
5029-B West W.T. Harris Blvd.
Charlotte, NC 28269
Tel: (704) 597-9292
FAX: (704) 596-9561

SMC Pneumatics Inc. (Detroit)
2990 Technology Drive
Rochester Hills, MI 48309
Tel: (248) 299-0202
FAX: (248) 293-3333

SMC Pneumatics Inc. (Newark)
3434 US Hwy. 22 West, Ste. 110
Somerville, NJ 08876
Tel: (908) 253-3241
FAX: (908) 253-3452

SMC Pneumatics Inc. (St. Louis)
4130 Rider Trail North
Earth City, MO 63045
Tel: (314) 209-0080
FAX: (314) 209-0085

SMC Pneumatics Inc. (Chicago)
27725 Diehl Road
Warrenville, IL 60555
Tel: (630) 393-0080
FAX: (630) 393-0084

SMC Pneumatics Inc. (Houston)
9001 Jameel, Suite 180
Houston, TX 77040
Tel: (713) 460-0762
FAX: (713) 460-1510

SMC Pneumatics Inc. (Phoenix)
2001 W. Melinda Lane
Phoenix, AZ 85027
Tel: (623) 492-0908
FAX: (623) 492-9493

SMC Pneumatics Inc. (Tampa)
8507-H Benjamin Road
Tampa, FL 33634
Tel: (813) 243-8350
FAX: (813) 243-8621

SMC Pneumatics Inc. (Cincinnati)
4598 Olympic Blvd.
Erlanger, KY 41018
Tel: (606) 647-5600
FAX: (606) 647-5609

SMC Pneumatics Inc. (L.A.)
14191 Myford Road
Tustin, CA 92780
Tel: (714) 669-1701
FAX: (714) 669-1715

SMC Pneumatics Inc. (Portland)
14107 N.E. Airport Way
Portland, OR 97230
Tel: (503) 252-9299
FAX: (503) 252-9253

SMC Pneumatics Inc. (Tulsa)
10203 A East 61st Street
Tulsa, OK 74146
Tel: (918) 252-7820
FAX: (918) 252-9511

Europe
ENGLAND
SMC Pneumatics (U.K.) Ltd.
GERMANY
SMC Pneumatik GmbH
ITALY
SMC Italia SpA
FRANCE
SMC Pneumatique SA
HOLLAND
SMC Controls BV
SWEDEN
SMC Pneumatics Sweden AB
SWITZERLAND
SMC Pneumatik AG
AUSTRIA
SMC Pneumatik GmbH
SPAIN
SMC España, S.A.
IRELAND
SMC Pneumatics (Ireland) Ltd.
Asia
JAPAN

SMC Corporation
KOREA
SMC Pneumatics Korea Co., Ltd.
CHINA
SMC (China) Co., Ltd.
HONG KONG
SMC Pneumatics (Hong Kong) Ltd.
SINGAPORE
SMC Pneumatics (S.E.A.) Pte. Ltd.
PHILIPPINES
SMC Pneumatics (Philippines), Inc.
MALAYSIA
SMC Pneumatics (S.E.A.) Sdn. Bhd.
TAIWAN
SMC Pneumatics (Taiwan) Co., Ltd.
THAILAND
SMC Thailand Ltd.
INDIA
SMC Pneumatics (India) Pvt., Ltd.
North America
CANADA
SMC Pneumatics (Canada) Ltd.
MEXICO
SMC Pneumatics (Mexico) S.A. de C.V.

South America
ARGENTINA
SMC Argentina S.A.
CHILE
SMC Pneumatics (Chile) Ltda.

Oceania
AUSTRALIA
SMC Pneumatics (Australia) Pty. Ltd.
NEW ZEALAND
SMC Pneumatics (N.Z.) Ltd.

SMC offers the same quality and engineering expertise in many other pneumatic components

Valves
Directional Control Valves
Manual Valves
Mufflers
Exhaust Cleaners
Quick Exhaust Valves

Valves
Proportional Valves
Mechanical Valves
Miniature Valves
Fluid Valves

Cylinders/Actuators
Compact Cylinders
Miniature Cylinders
Rodless Cylinders
Rotary Actuators
Pneumatic Grippers

Vacuum
Vacuum Ejectors
Vacuum Accessories
Instrumentation
Pneumatic Positioners
Pneumatic Transducers

Air Preparation Equipment
Filters-Regulators-Lubricators
Coalescing Filters
Micro Mist Separators
Fittings
Air Fittings

SMC Pneumatics Inc.

P.O. Box 26640, Indianapolis, IN 46226
Tel: (317) 899-4440 • FAX: (317) 899-3102