

3 Port Solenoid Valve Direct Operated Poppet Type Series VT307 Rubber Seal



Compact yet provides a large flow capacity

Dimensions (W x H x D)---30 x 54.5 x 33
(Grommet)

C: 0.71 dm³/(s·bar)
{Rc 1/4 (Passage 2 → 3)}

Low power consumption

VT/VO307.....4.8 W DC/Standard type
VT/VO307Y).....2 W DC/Energy-saving type
VT/VO307W)

Suitable for use in vacuum applications

-101.2 kPa
(For vacuum specifications type: VT/VO307V,
VT/VO307W)

A single valve with 6 valve functions

(Universal porting type)
Selective porting can provide 6 valve functions, such as N.C. valve, N.O. valve, Divider valve, Selector valve, etc.



JIS Symbol

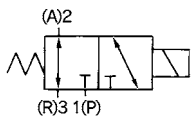

How to Order

V T 307 [] - 5 D [] - 01 [] - F - []

Body type

T	Body ported
0	Manifold

Valve option

Nil	Standard type
E*	Continuous duty type
Y*	Energy-saving type (2 W DC)
V*	For vacuum
W*	Energy-saving type, For vacuum

* Option

Rated voltage

1	100 VAC, 50/60 Hz
2	200 VAC, 50/60 Hz
3	110 VAC, 50/60 Hz
4*	220 VAC, 50/60 Hz
5	24 VDC
6*	12 VDC
7*	240 VAC, 50/60 Hz
9*	Other

* Option

Electrical entry

G	Grommet, 300 mm lead wire
H	Grommet, 600 mm lead wire
D	DIN terminal
E	Grommet terminal
T	Conduit terminal

Option

F	With foot bracket
---	-------------------

Thread type

Nil	Rc
F	G
N	NPT
T	NPTF

CE-compliant

Nil	---
Q	CE-compliant*

* Electrical entry: D/DO, DZ/DOZ only

Port size

Nil	Without port (For manifold)
01	1/8 (6A)
02	1/4 (8A)

Light/Surge voltage suppressor

Nil	None
S	With surge voltage suppressor (Grommet type is only available.) Refer to the figure below.
Z	With light/surge voltage suppressor (Except grommet type)

* As for the case of rated voltage [Others (9)], please contact SMC.

Surge voltage suppressor mounting part

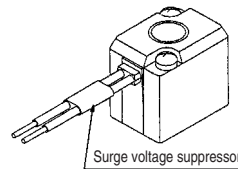

Manifold

Model	Applicable manifold type	Accessory
VO307□(-Q)	Common or individual exhaust	Function plate (DXT152-14-1A) ^{Note} Mounting screw (NXT013-3)



^{Note} It is not applied to "Continuous duty type". Refer to the accessories on page 1605.

Option

Description	Part no.
Bracket	DXT152-25-1A (With thread)

VV061

V100

S070

VQD

VKF

VK

VT

VS

Series VT307

⚠ Precautions

Be sure to read before handling. Refer to front matters 58 and 59 for Safety Instructions and pages 3 to 7 for 3/4/5 Port Solenoid Valve Precautions.

⚠ Caution

1. Make sure that dust and/or other foreign materials do not enter the valve from the unused port (e.g. exhaust port). Also, since there is a breathing port for the armature in the manual override part, do not allow accumulation of dust and/or other foreign materials to block bleed port.

How to Calculate the Flow Rate

For obtaining the flow rate, refer to front matters 44 to 47.

Standard Specifications

Type of actuation	Direct operated type 2 position single solenoid	
Fluid	Air	
Operating pressure range	0 to 0.9 MPa	
Ambient and fluid temperature	-10 to 50°C (No freezing. Refer to page 5.)	
Response time ⁽¹⁾	20 ms or less (at the pressure of 0.5 MPa)	
Max. operating frequency	10 Hz	
Lubrication	Not required (Use turbine oil Class 1 ISO VG32, if lubricated.)	
Manual override	Non-locking push type	
Mounting orientation	Unrestricted	
Shock/Vibration resistance ⁽²⁾	150/50 m/s ²	
Enclosure	Dustproof	

Electrical entry	Grommet, Grommet terminal, Conduit terminal, DIN terminal	
Coil rated voltage (V)	AC (50/60 Hz)	100, 200, 110*, 220*, 240*
	DC	24, 12*
Allowable voltage fluctuation	-15 to +10% of rated voltage	
Apparent power ⁽³⁾⁽⁴⁾	AC	Inrush 12.7 VA (50 Hz) 10.7 VA (60 Hz) Holding 7.6 VA (50 Hz) 5.4 VA (60 Hz)
	DC	Without indicator light: 4.8 W, With indicator light: 5 W
Power consumption ⁽³⁾⁽⁴⁾	DC	Without indicator light: 4.8 W, With indicator light: 5 W
Light/Surge voltage suppressor (Not applicable for grommet type)	AC	Varistor, Neon bulb
	DC	Diode, LED (Neon bulb for 100 V or more)

* Option
Note 1) Based on dynamic performance test, JIS B 8374-1981. (Coil temperature: 20°C, at rated voltage, without surge suppressor)

Note 2) Impact resistance: No malfunction occurred when it is tested with a drop tester in the axial direction and at the right angles to the main valve and armature in both energized and de-energized states every once for each condition. (Values at the initial period)

Vibration resistance: No malfunction occurred in a one-sweep test between 45 and 1000 Hz. Test was performed at both energized and de-energized states in the axial direction and at the right angles to the main valve and armature. (Values at the initial period)

Note 3) At rated voltage

Note 4) The value is different for continuous duty type (VT307E), and energy-saving type (VT307Y/W). Refer to "Option" shown below.

Flow Characteristics/Mass

Valve model	Port size	Flow characteristics												Mass
		1 → 2 (P → A)			2 → 3 (A → R)			3 → 2 (R → A)			2 → 1 (A → P)			
		C [dm ³ /(s·bar)]	b	Cv	C [dm ³ /(s·bar)]	b	Cv	C [dm ³ /(s·bar)]	b	Cv	C [dm ³ /(s·bar)]	b	Cv	
VT307	1/8	0.71	0.35	0.18	0.68	0.27	0.17	0.65	0.36	0.17	0.63	0.35	0.17	0.14 kg
VT307V (Vacuum spec. type)		0.41	0.26	0.10	0.44	0.35	0.11	0.48	0.27	0.12	0.35	0.33	0.10	
VT307E (Continuous duty type)		0.71	0.31	0.19	0.71	0.25	0.17	0.68	0.33	0.17	0.71	0.26	0.18	
VT307Y (Energy-saving type)		0.49	0.20	0.12	0.44	0.34	0.11	0.48	0.17	0.12	0.46	0.28	0.11	
VT307W (Energy-saving, Vacuum spec. type)	1/4	0.71	0.31	0.19	0.71	0.25	0.17	0.68	0.33	0.17	0.71	0.26	0.18	
VT307V (Vacuum spec. type)		0.41	0.26	0.10	0.44	0.35	0.11	0.48	0.27	0.12	0.35	0.33	0.10	
VT307E (Continuous duty type)		0.71	0.31	0.19	0.71	0.25	0.17	0.68	0.33	0.17	0.71	0.26	0.18	
VT307Y (Energy-saving type)		0.49	0.20	0.12	0.44	0.34	0.11	0.48	0.17	0.12	0.46	0.28	0.11	
VT307W (Energy-saving, Vacuum spec. type)														

Note) Values for a single valve unit. It differs in the manifold case. Refer to manifold specifications on page 1605.

Option

Continuous duty type: VT307E

Exclusive use of VT307E is recommended for continuous duty with long time loading.

⚠ Caution

- This model is for continuous duty, not for high cycle rates. But even in low cycle rates, if energizing the valve more than once a day, please consult with SMC.
- Energizing solenoid should be done at least once in 30 days.

Specifications different from standard are as follows.

Apparent power/AC	Inrush	7.9VA (50 Hz), 6.2VA (60 Hz)
	Holding	5.8VA (50 Hz), 3.5VA (60 Hz)
Power consumption/DC	2 W, 2.2 W (With indicator light)	
Response time ⁽¹⁾	30 ms or less (at the pressure of 0.5 MPa)	

Note 1) Refer to Note 1) of standard specifications.

Note 2) For the flow characteristics, refer to "Flow Characteristics".

Energy-saving type: VT307Y (VT307W)

If low power consumption is required for electronic control, "VY307Y(W)" (2 W DC) is recommended. Specifications different from standard are as follows.

Power consumption/DC	2 W, 2.2 W (With indicator light)*
Response time ⁽¹⁾	25 ms or less (at 0.5 MPa)

* 100 VDC: 2.4 W

Note 1) Refer to Note 1) of standard specifications.

Note 2) For the flow characteristics, refer to "Flow Characteristics".

Vacuum spec. type: VT307V (VT307W)

This vacuum model has less air leakage than the standard model under low pressure. It is recommended for vacuum application.

⚠ Caution

- Since this valve has slight air leakage, it can not be used for vacuum holding (including positive pressure holding) in the pressure container.

Specifications different from standard are as follows.

Operating pressure range	-101.2 kPa to 0.1 MPa
--------------------------	-----------------------

Construction

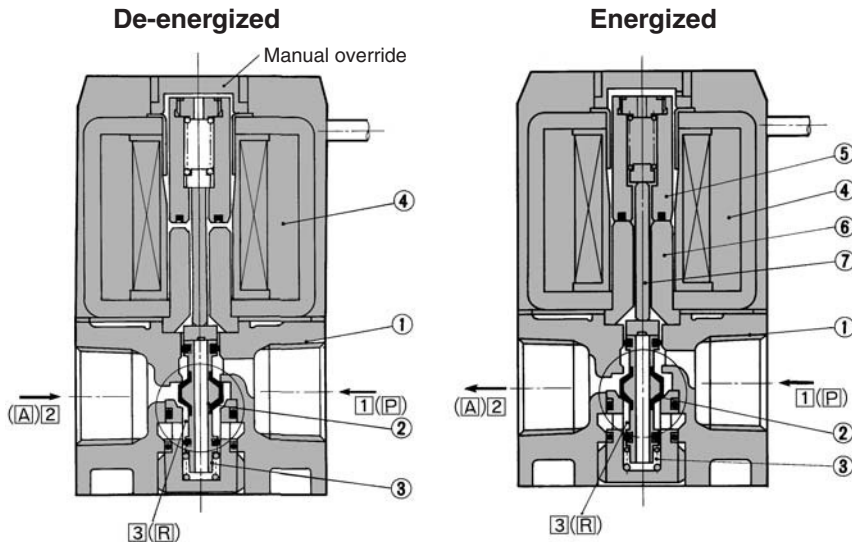

Operation principle <De-energized>

Spool valve (2) is pushed upward by the return spring (3), port P (1) is closed, and then port A (2) and port R (3) are opened.

Air flow direction:

Port P ↔ Block, A ↔ R

<Energized>

When an electric current is applied to the molded coil (4), the armature (5) is attracted to the core (6), and through the push rod (7), it pushes down the spool valve (2) and port R (3) is closed. Then, port P (1) and port A (2) are connected. At this time, there will be gaps between the armature (5) and the core (6), but the armature (5) will be magnetically attracted to the core (6).

Air flow direction:

Port P ↔ Port A, Port R ↔ Block

Component Parts

No.	Description	Material	Note
1	Body	Aluminum die-casted	Color: Platinum silver
2	Spool valve	Aluminum, NBR	
3	Return spring	Stainless steel	
4	Molded coil	Resin	

How to Use DIN Terminal

1. Disassembly

- After loosening the thread (1), then if the housing (2) is pulled in the direction of the thread (1), the connector will be removed from the body of equipment (solenoid, etc.).
- Pull the thread (1) out of the housing (2).
- On the bottom part of the terminal block (3), there's a cut-off part (9). If a small flat head screwdriver is inserted between the opening in the bottom, terminal block (3) will be removed from the housing (2). (Refer to "Figure 1".)
- Remove the cable gland (4) and plain washer (5) and rubber seal (6).

2. Wiring

- Passing through the cable (7), cable gland (4), plain washer (5), rubber seal (6) in this order, and then insert into the housing (2).
- From the terminal block (3), loosen the screw (11), then pass the lead wire (10) through, then again tighten the screw (11).
Note 1) Tighten within the tightening torque of 0.5 N·m ±15%.
Note 2) Cable (7) external: ø6 to ø8 mm
Note 3) Crimped terminal like round-shape or Y shape cannot be used.

3. Assembly

- Passing cable gland (4), washer (5), rubber seal (6), housing (2) in this order through cable (7) and connect to terminal block (3) and then set the terminal block (3) to the housing (2). (Push it down until you hear the click sound.)
- Putting rubber seal (6), plain washer (5), in this order into the cable introducing slit on the housing (2), then further tighten the cable gland (4) securely.
- Insert the gasket (8) between the bottom part of terminal block (3) and a plug attached to equipment, and then screw (1) in from the top of the housing (2) to tighten it.
Note 1) Tighten within the tightening torque of 0.5 N·m ±20%.
Note 2) Connector orientation can be changed by 180 degrees depending on how to assemble the housing (2) and the terminal block (3).

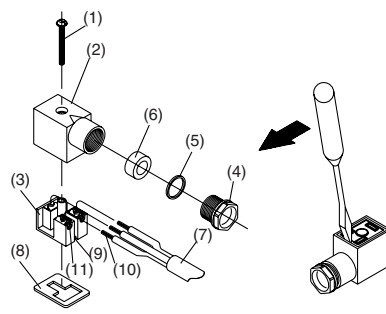

Connector for DIN Terminal

Description	Part no.
DIN connector	B1B09-2A(Standard)
	GM209NJ-B17(CE-compliant)

⚠ Caution

Light/Surge Voltage Suppressor

AC, 100 VDC or more

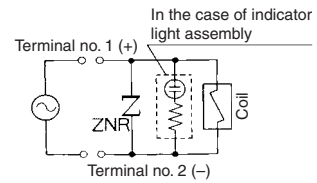

48 VDC or less

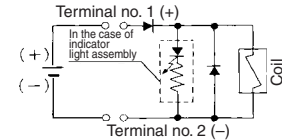

Electrical Connection

DIN terminal and terminal (with light/surge voltage suppressor) are connected inside as in the figure below. Connect to the corresponding power supply.

DIN terminal block

Terminal block

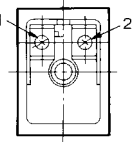
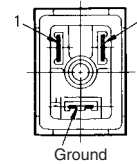

Terminal no.	1	2
DIN terminal	+	-
Terminal	+	-

- Applicable cable O.D.

Type T: ø4.5 to ø7 mm

Type E: ø2.3 to ø2.8 mm

Type D: ø6 to ø8 mm

- Applicable crimp terminal

Type E/T: 1.25-3, 1.25-3S

1.25Y-3N, 1.25Y-3S

(Round or "Y" shaped crimped terminals)
can not be used for type "D".

Lead Wire Color

Voltage	Color
100 VAC	Blue
200 VAC	Red
DC	Red (+), Black (-)
Other	Gray

Series VT307

Dimensions (Interchangeable with "VT301" for mounting)

Grommet: VT307-□G

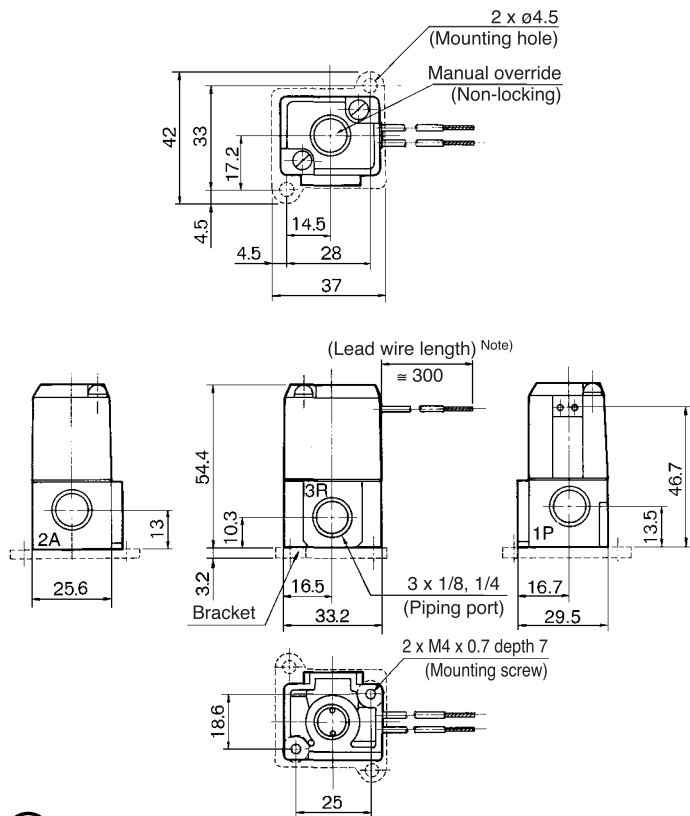

Note) There is also "VT307-□H" (lead wire length: 600 mm).

Grommet terminal: VT307-□E

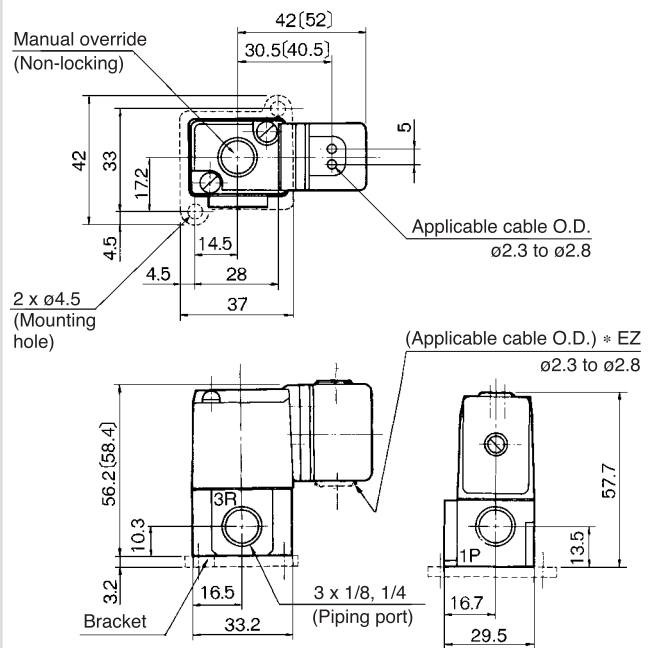

[]: With light/surge voltage suppressor

Conduit terminal: VT307-□T

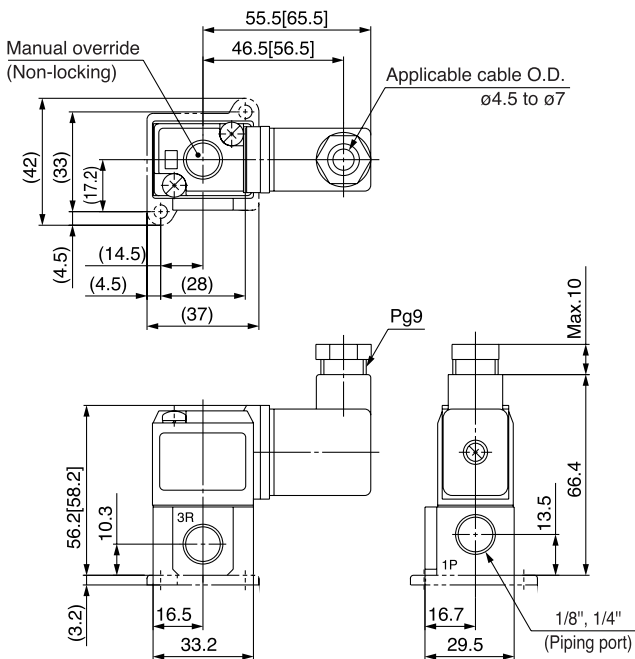

[]: With light/surge voltage suppressor

DIN terminal: VT307-□D

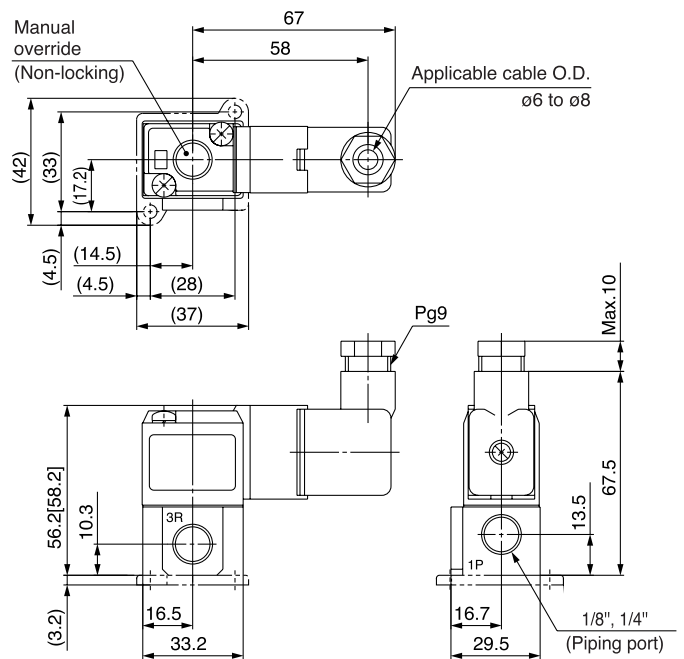

[]: With light/surge voltage suppressor

Series VT307

Manifold Specifications

VT307 manifold is B mount style and available both as a common exhaust and individual exhaust model.

Manifold valve can be easily converted from N.C. (Normally Closed) to N.O. (Normally Open) merely by turning over the switch cover.



How to Order Manifold

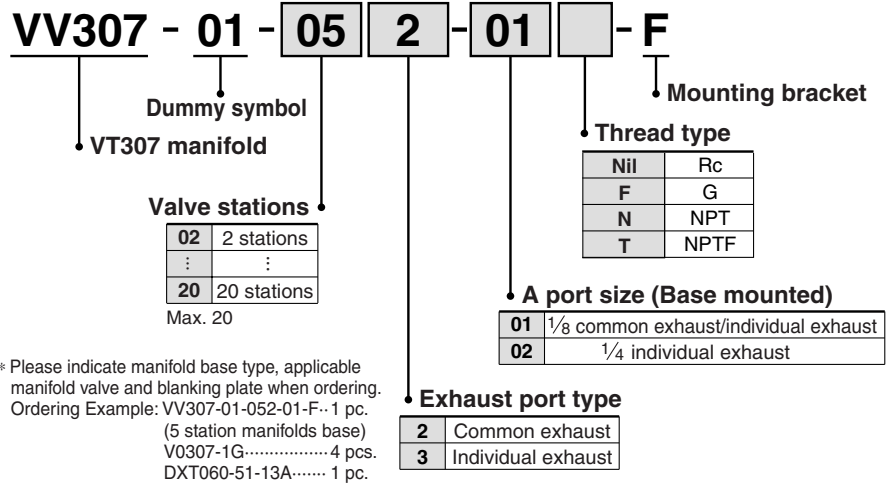

Manifold Specifications

Manifold type	B mount			
Max. number of stations	20 stations ^{Note)}			
Applicable solenoid valve	VO307□-□□□□ (-Q)			
Exhaust port		Port location (Direction)/Port size		
Symbol	Type	P	A	R
2	Common	Base (Side) 1/8	Base (Side) 1/8	Base (Side) 1/8
3	Individual	Base (Side) 1/4	Base (Side) 1/8, 1/4	Base (Top) 1/8

Note) For more than 6 stations, supply air both sides of P port. The common exhaust type should exhaust from both of the R port.

Option

Description	Part no.
Blanking plate (With gasket, screw) ^{Note)}	DXT060-51-13 ^A _B

Accessory for Applicable Solenoid

Description	Part no.	Qty.
Function plate (With gasket) ⁽¹⁾	DXT152-14-1 ^A _B	1 pc.
Mounting screw	NXT013-3	2 pcs.

Note 1) DXT060-51-13B, DXT152-14-1B are for energizing continuously.

Flow Characteristics/Mass

Valve model	Flow characteristics												Mass
	1 → 2 (P → A)			2 → 3 (A → R)			3 → 2 (R → A)			2 → 1 (A → P)			
	C [dm ³ /(s·bar)]	b	Cv	C [dm ³ /(s·bar)]	b	Cv	C [dm ³ /(s·bar)]	b	Cv	C [dm ³ /(s·bar)]	b	Cv	
VO307	0.34	0.28	0.089	0.34	0.22	0.082	0.36	0.28	0.091	0.34	0.18	0.080	0.14kg
VO307V (Vacuum spec. type)													
VO307E (Continuous duty type)													
VO307Y (Energy-saving type)													
VO307W (Energy-saving, Vacuum spec. type)	0.30	0.18	0.070	0.30	0.15	0.072	0.32	0.20	0.075	0.30	0.15	0.069	

Series VT307

Dimensions: Common Exhaust (Interchangeable with VT301 for mounting)

VV307-01-□2-01-F

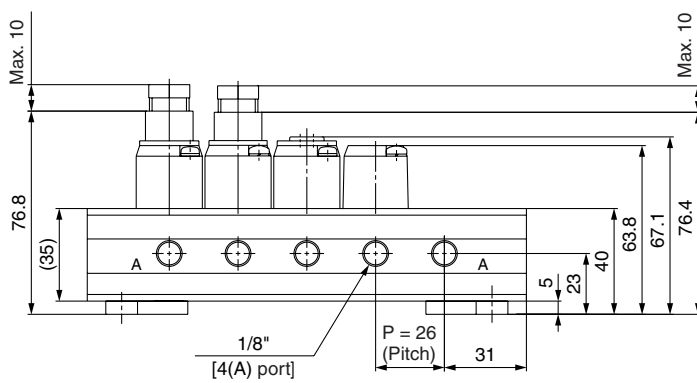
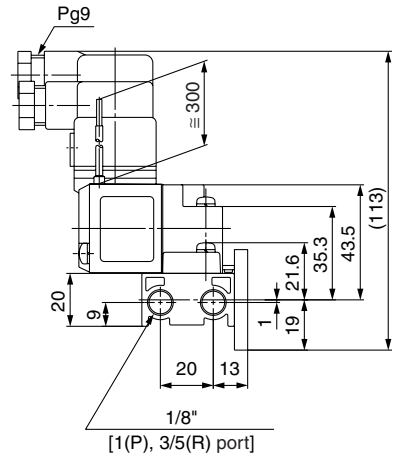
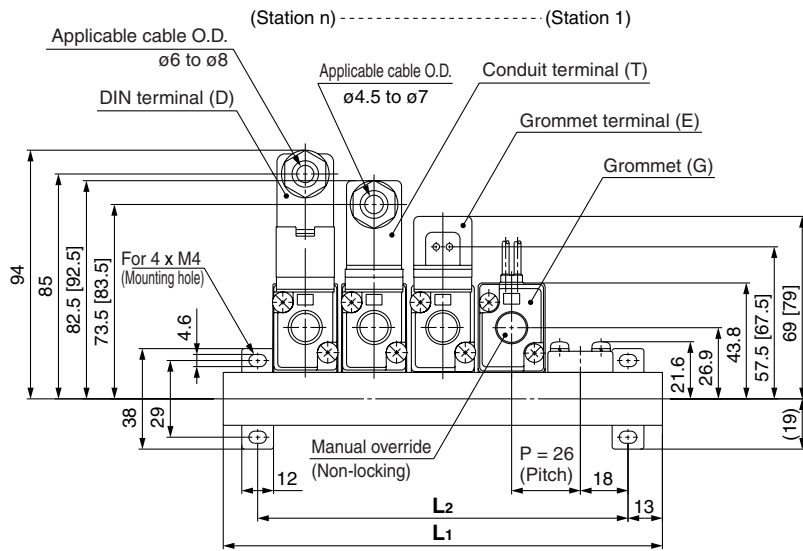
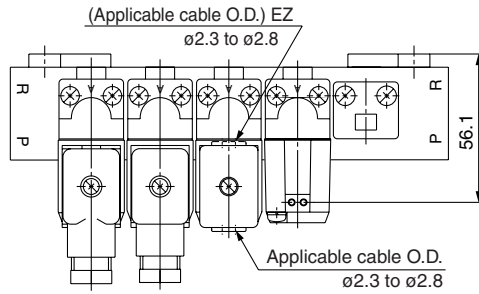

L Dimension

n: Stations

L	n	2	3	4	5	6	7	8	9	10	Formula
L ₁		88	114	140	166	192	218	244	270	296	L ₁ = 26 x n + 36
L ₂		62	88	114	140	166	192	218	244	270	L ₂ = 26 x n + 10



[]: With light/surge voltage suppressor

Dimensions: Individual Exhaust (Interchangeable with VT301 for mounting)

VV307-01-□3-□-F

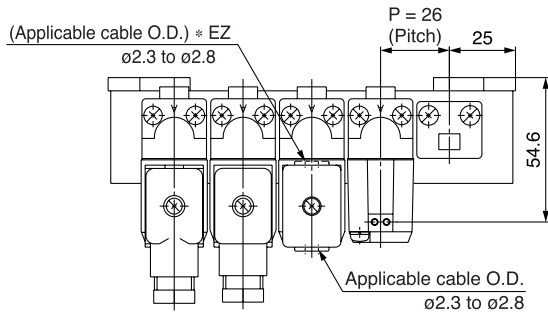

(Station n)----- (Station 1)

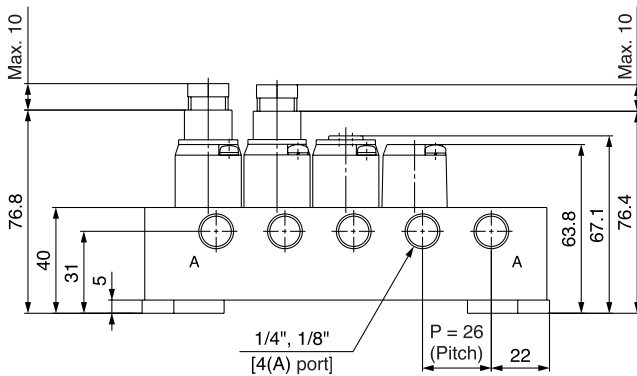
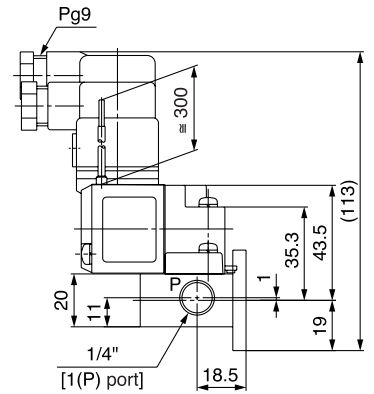
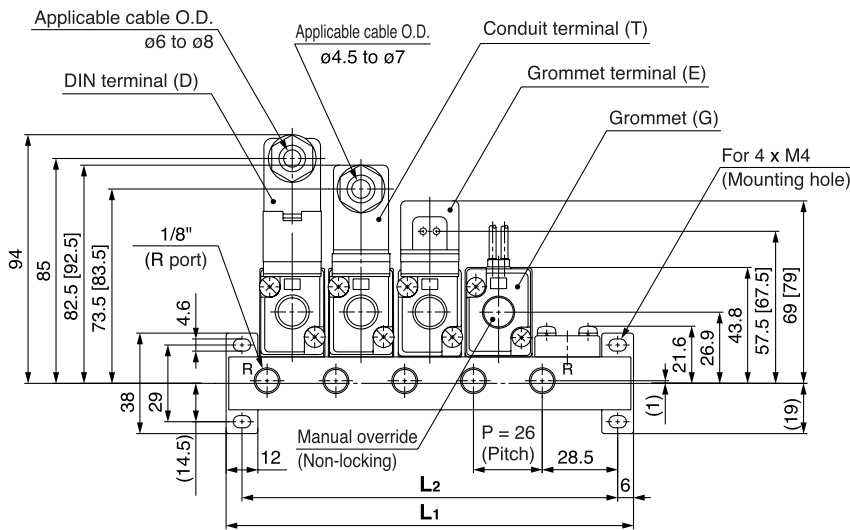

- VV061
- V100
- S070
- VQD
- VKF
- VK
- VT**
- VS



[] : With light/surge voltage suppressor

L Dimension

n: Stations

Stations	2	3	4	5	6	7	8	9	10	Formula
L ₁	76	102	128	154	180	206	232	258	284	L ₁ = 26 x n + 24
L ₂	64	90	116	142	168	194	220	246	272	L ₂ = 26 x n + 12



Series VT307 Specific Product Precautions

Be sure to read before handling. Refer to Front matters 58 and 59 for Safety Instructions and pages 3 to 7 for 3/4/5 Port Solenoid Valve Precautions.

Mounting

⚠ Warning

When mounting a valve on the manifold base, N.C. and N.O. can be reversed by a function plate orientation. Also, since cylinder also acts reversely, confirm if the function plate is correctly mounted or not.

N.C.
specifications

N.O.
specifications

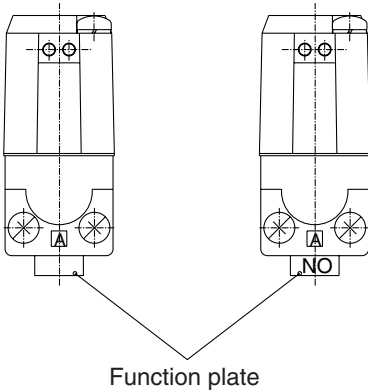

⚠ Caution

1. Each valve is fixed to the manifold base with two M4 mounting screws. Tighten the screws evenly when re-mounting.
2. For mounting, tighten M4 or equivalent screws evenly into the mounting holes of the manifold base. Tightening torque of the mounting screw (M4): 1.4 N·m

Port Direction

⚠ Caution

1. For the common exhaust type, pressurization or evacuation of the R port can cause a malfunction.

Changing from N.C. to N.O.

⚠ Caution

This product is delivered as N.C. valve. If N.O. valve is needed, remove mounting screws of the required valve and turn over the function plate. (Make sure that there are gaskets on both sides of the plate.) Then, tighten the mounting screws to fix the valve to the manifold base.

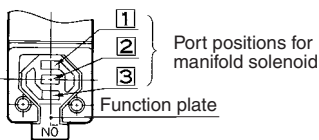

Figure: For N.C.

Specifications	Function plate
N.C.	No mark
N.O.	NO

3 Port Solenoid Valve Direct Operated Poppet Type Series VT317 Rubber Seal



Compact yet provides a large flow capacity

Dimensions (W x H x D).....45 x 89.5 x 45
(Grommet)

C: 2.6 dm³/(s·bar)
(Passage 2 → 3)

Suitable for use in vacuum applications

-101.2 kPa
(For vacuum specifications: VT/VO317V)

A single valve with 6 valve functions

(Universal porting type)
Selective porting can provide 6 valve functions, such as N.C. valve, N.O. valve, Divider valve, Selector valve etc.



JIS Symbol

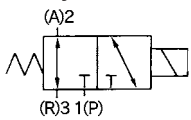

How to Order

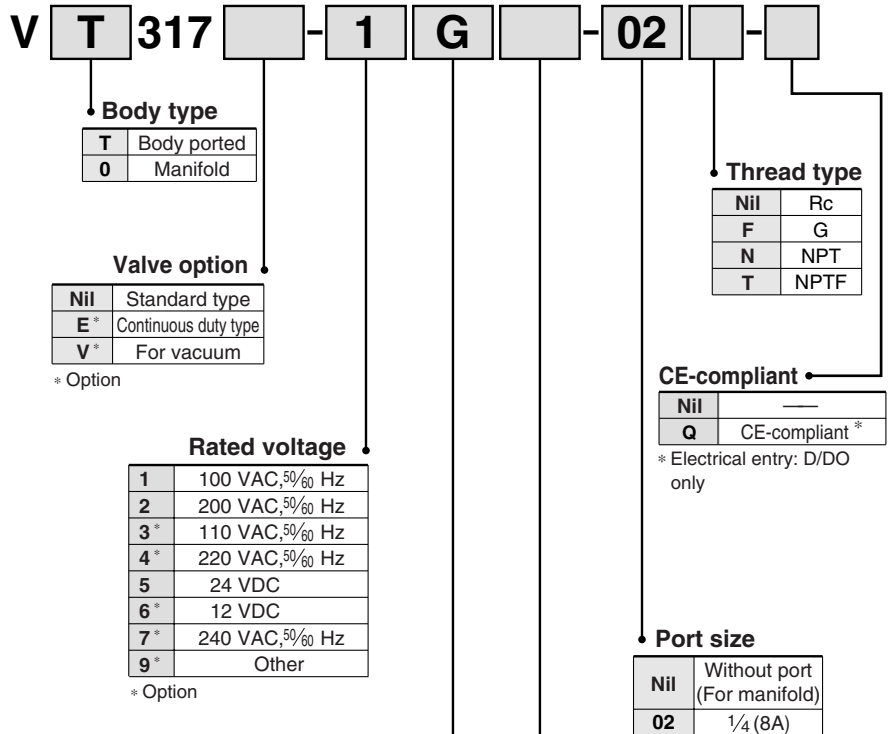

Electrical entry

G	Grommet, 300 mm lead wire
H	Grommet, 600 mm lead wire
C	Conduit
T	Conduit terminal
D	DIN terminal

Light/Surge voltage suppressor

Electrical entry	G	H	C	T	D
Symbol					
Nil	—	—	—	—	—
S	● (Note)	● (Note)	● (Note)	●	●
Z	—	—	—	●	●

S: With surge voltage suppressor
Note) Refer to the figure below.
Z: With light/surge voltage suppressor
* As to the case of rated voltage [Others (9)], please contact SMC.

Surge voltage suppressor mounting part (For "G")

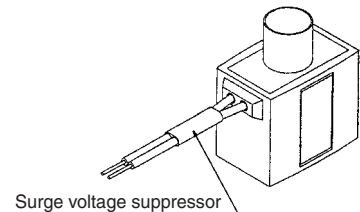

Manifold

Model	Applicable manifold type	Accessory
VO317(-Q)	Common or individual exhaust	O-ring (P10, 4 pcs.) Note) Bolts (M4 x 0.7 x 20, 2 pcs.)

Note) It is not applied to "Continuous duty type". Refer to the accessories on page 1612.

Standard Specifications

Type of actuation		Direct operated type 2 position single solenoid
Fluid		Air
Operating pressure range		0 to 0.9 MPa
Ambient and fluid temperature		-10 to 50°C (No freezing. Refer to page 5.)
Response time ⁽¹⁾		30 ms or less (at the pressure of 0.5 MPa)
Max. operating frequency		10 Hz
Lubrication		Not required (Use turbine oil Class 1 ISO VG32, if lubricated.)
Manual override		Non-locking push type
Mounting orientation		Unrestricted
Shock/Vibration resistance ⁽²⁾		150/50 m/s ²
Enclosure		Dustproof
Electrical entry		Grommet, Conduit, Conduit terminal, DIN terminal
Coil rated voltage (V)	AC (50/60 Hz)	100, 200, 110*, 220*, 240*
	DC	24, 12*
Allowable voltage fluctuation		-15 to +10% of rated voltage
Apparent power ⁽³⁾	AC	19 VA (50 Hz), 16 VA (60 Hz)
	Inrush Holding	11 VA (50 Hz), 7 VA (60 Hz)
Power consumption ⁽³⁾	DC	Without indicator light: 6 W, With indicator light: 6.3 W
Light/Surge voltage suppressor (Not applicable for grommet type)	AC	Varistor, Neon bulb
	DC	Varistor, LED (Neon bulb for 100 V or more)



* Option

Note 1) Based on dynamic performance test, JIS B 8374-1981. (Coil temperature: 20°C, at rated voltage, without surge suppressor)

Note 2) Impact resistance: No malfunction occurred when it is tested with a drop tester in the axial direction and at the right angles to the main valve and armature in both energized and de-energized states every once for each condition. (Values at the initial period)

Vibration resistance: No malfunction occurred in a one-sweep test between 45 and 1000 Hz. Test was performed at both energized and de-energized states in the axial direction and at the right angles to the main valve and armature. (Values at the initial period)

Note 3) At rated voltage

Flow Characteristics/Mass

Valve model	Flow characteristics												Mass
	1 → 2 (P → A)			2 → 3 (A → R)			3 → 2 (R → A)			2 → 1 (A → P)			
	C [dm ³ /(s·bar)]	b	Cv	C [dm ³ /(s·bar)]	b	Cv	C [dm ³ /(s·bar)]	b	Cv	C [dm ³ /(s·bar)]	b	Cv	
VT317													
VT317V (Vacuum spec. type)	2.4	0.26	0.62	2.6	0.34	0.67	2.8	0.25	0.67	2.5	0.37	0.66	0.29kg
VT317E (Continuous duty type)													

Note) Values for a single valve unit. It differs in the manifold case. Refer to manifold specifications on page 1612.

Option

Continuous duty type: VT317E

Exclusive use of VT317E is recommended for continuous duty with long time loading.

⚠ Caution

- This model is for continuous duty, not for high cycle rates. But even in low cycle rates, if energizing the valve more than once a day, please consult with SMC.
- Energizing solenoid should be done at least once in 30 days.

Vacuum spec. type: VT317V

This vacuum model has less air leakage than the standard model under low pressure. It is recommended for vacuum application.

⚠ Caution

- Since this valve has slight air leakage, it can not be used for vacuum holding (including positive pressure holding) in the pressure container.

Specifications different from standard are as follows.

Operating pressure range	-101.2 kPa to 0.1 MPa
--------------------------	-----------------------

Construction

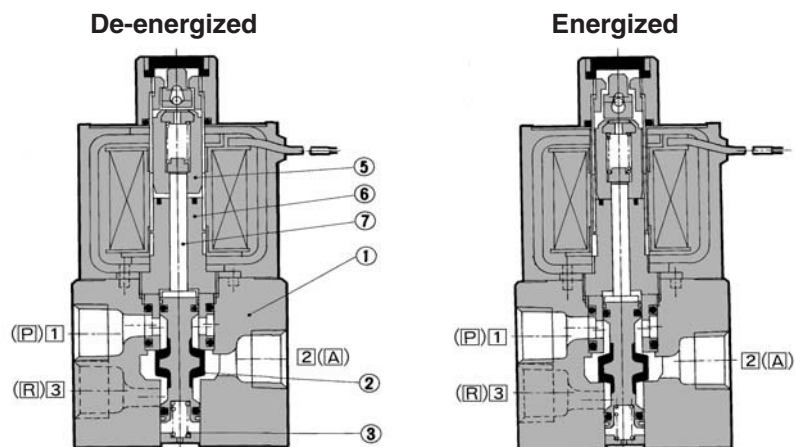

Operation principles

<De-energized>

Spool valve ② is pushed upward by the return spring ③, port P ① is closed, and port A ② and port R ③ are opened.

<Energized>

When an electric current is applied to the molded coil ④, the armature ⑤ is attracted to the core ⑥, and through the push rod ⑦, it pushes down the spool valve ②. Then, port P ① and port A ② are connected. At this time, there will be gaps between the armature ⑤ and the core ⑥, but the armature will be magnetically attracted to the core ⑥.

Component Parts

No.	Description	Material	Note
1	Body	Aluminum die-casted	Color: Platinum silver
2	Spool valve	Aluminum, NBR	

3 Port Solenoid Valve Direct Operated Poppet Type **Series VT317**

Dimensions

Grommet: VT317-□G

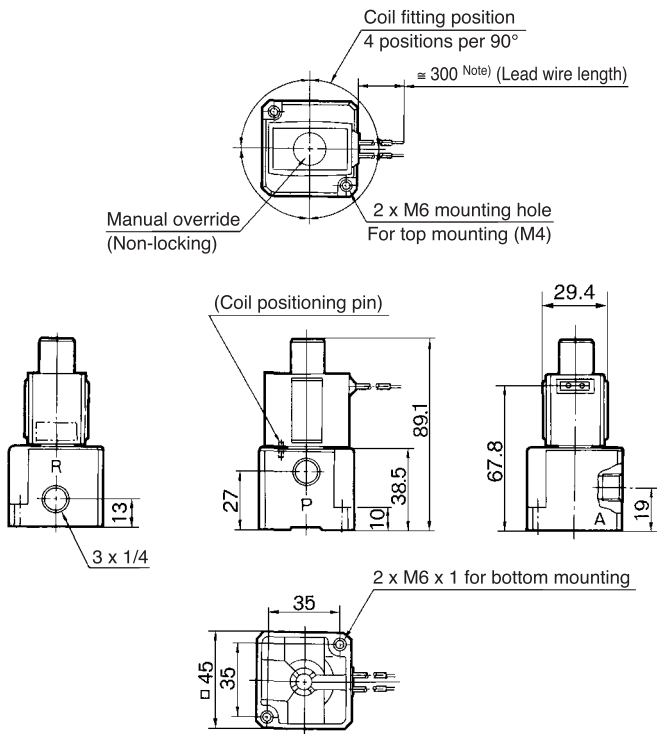

Conduit: VT317-□C

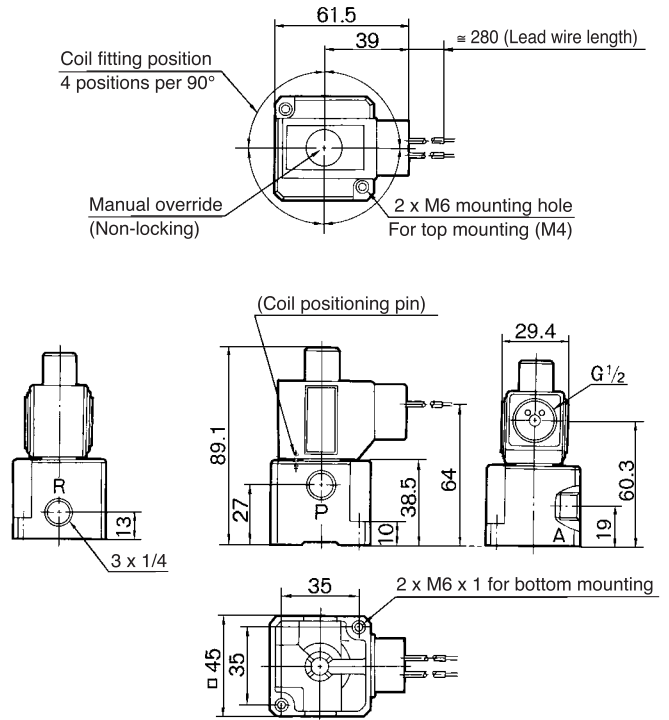

Note) There is also "VT317-□H" (Lead wire length: 600 mm).

Conduit terminal: VT317-□T

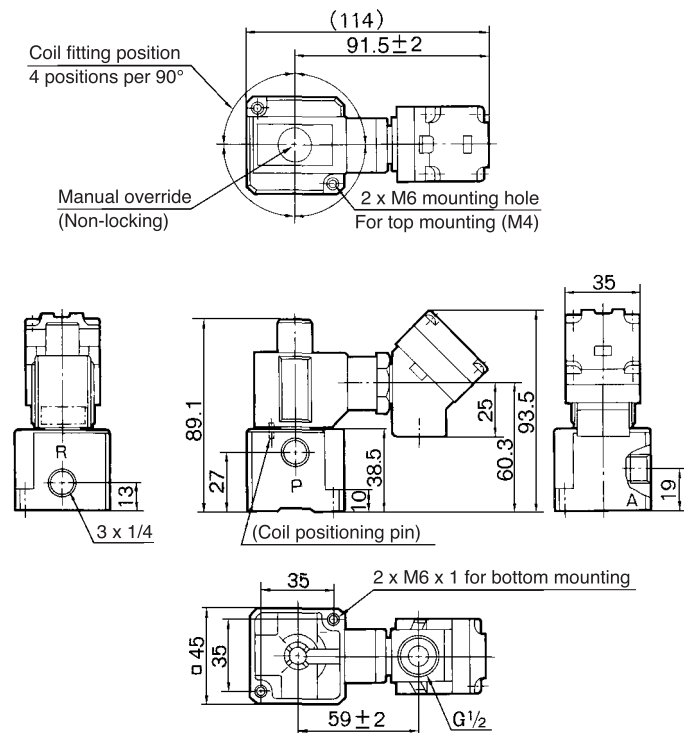

DIN terminal: VT317-□D

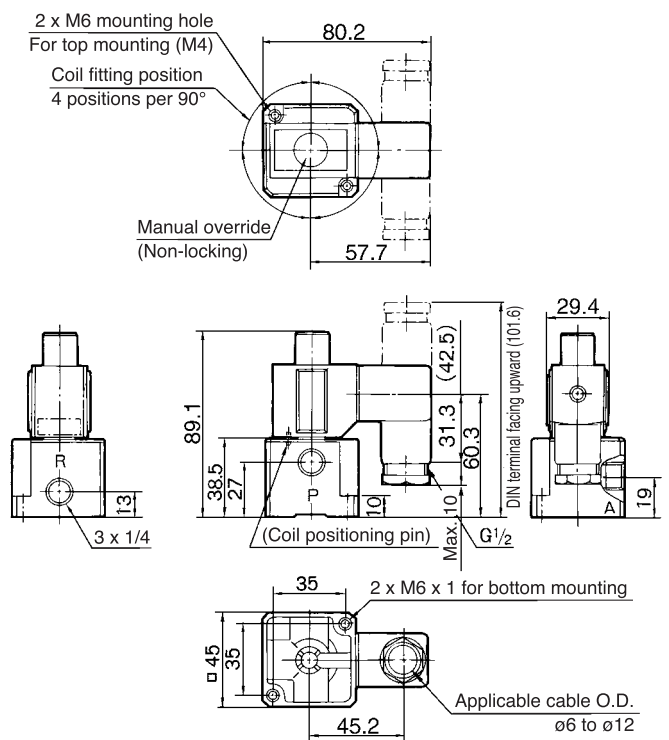

VV061

V100

S070

VQD

VKF

VK

VT

VS

Series VT317

Manifold Specifications

VT317 manifold is B mount style and available both as a common exhaust and individual exhaust model.

VV317-02-051-02-A



Common exhaust



VV317-02-051-02

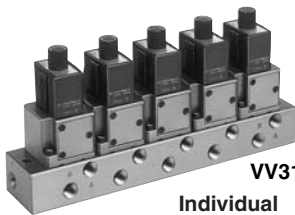

Individual exhaust

VV317-02-053-02

How to Order Manifold

VV317 - 02 - 05 1 - 02 □ - A

Base type: 1/4

Thread type

Nil	Rc
F	G
N	NPT
T	NPTF

Option
A Mounting bracket*
* Common exhaust type only

Valve stations

02	2 stations
:	:
20	20 stations

Max. 20

A port size (Base piping) 1/4

Symbol

Symbol	Passage		Porting specifications
	P	R	A
1	Common	Common	Side
3	Common	Individual	Side

VT317 manifold
* Please indicate manifold base type, applicable manifold valve and blanking plate when ordering.

Ordering example:
VV317-02-051-02-A..... 1 pc. (5-station manifold base)
VO317-1G..... 4 pcs.
PVT317-53-1A..... 1 pc. (Blanking plate)

Manifold Specifications

Manifold type	B mount
Max. number of stations	20 stations ⁽¹⁾
Applicable solenoid valve	VO317□-□□□(-Q) ⁽³⁾

Exhaust port		Port location (Direction)/Port size		
Symbol	Type	P	A	R
1	Common ⁽²⁾	Base (Side) 1/4 (3/8)	Base (Side) 1/4	Base (Side) 1/4 (3/8)
3	Individual	Base (Side) 1/4	Base (Side) 1/4	Base (Side) 1/4

Note 1) For more than 3 stations, supply air both sides of P port. The common exhaust type should exhaust from both of the R port.

Note 2) In the case of common exhaust type, R and P ports size can be Rc 3/8 by using a mounting adaptor.

Note 3) Can also be applied to Series VVT320 manifold.

Accessory for Applicable Solenoid

Description	Part no.	Qty	Note
O-ring	P10	4	Standard type vacuum specifications type
	P10F		Continuous duty type
Hexagon socket head screw	Max. 0.7 x 20	2	

Option

Description	Part no.
Blanking plate (With screw, O-ring)	PVT317-53-1A
Mounting bracket (With screw)	DXT010-37-4 (For common exhaust)

Flow Characteristics/Mass

Valve model	Flow characteristics												Mass	
	1 → 2 (P → A)			2 → 3 (A → R)			3 → 2 (R → A)			2 → 1 (A → P)				Grommet
	C [dm ³ /(s·bar)]	b	Cv	C [dm ³ /(s·bar)]	b	Cv	C [dm ³ /(s·bar)]	b	Cv	C [dm ³ /(s·bar)]	b	Cv		
VO317														
VO317V (Vacuum spec. type)	2.0	0.11	0.47	2.2	0.12	0.49	2.0	0.14	0.45	2.1	0.14	0.48	0.32kg	
VO317E (Continuous duty type)														

Dimensions: Common Exhaust (Interchangeable with VVT320 for mounting)

Without mounting bracket: VV317-02-□1-02

A single valve unit port location

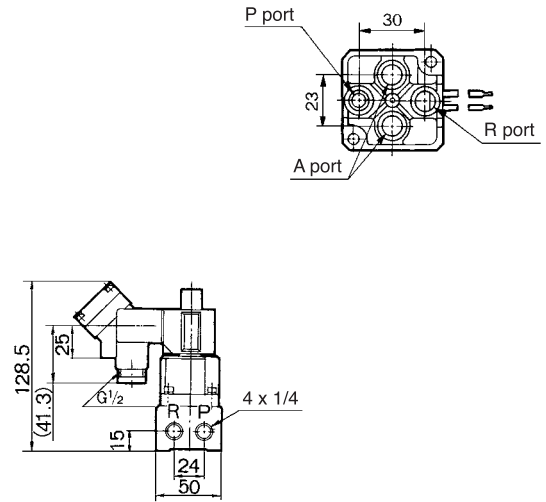
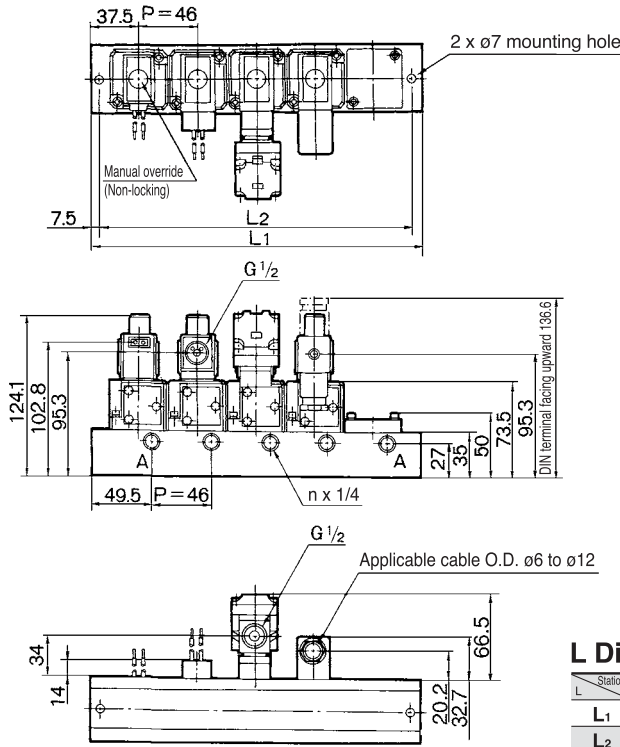

L Dimension

n: Stations

L	Stations	2	3	4	5	6	7	8	9	10	Formula
L ₁		121	167	213	259	305	351	397	443	489	L ₁ = 46 x n + 29
L ₂		106	152	198	244	290	336	382	428	474	L ₂ = 46 x n + 14

With mounting adaptor: VV317-02-□1-02-A

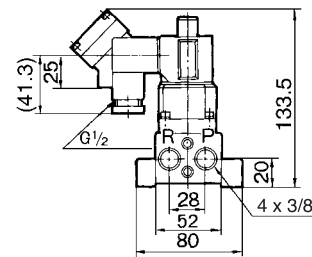
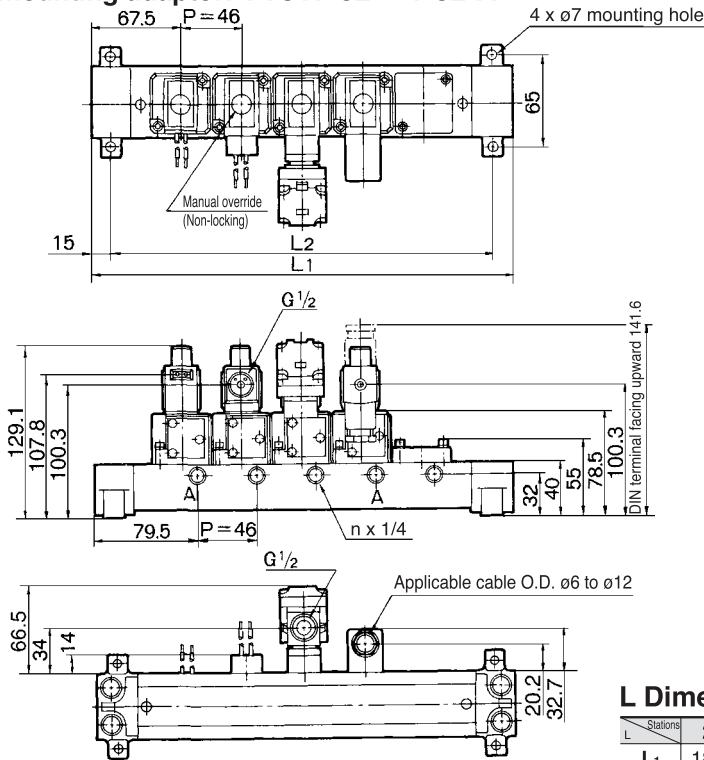

L Dimension

n: Stations

L	Stations	2	3	4	5	6	7	8	9	10	Formula
L ₁		181	227	273	319	365	411	457	503	549	L ₁ = 46 x n + 89
L ₂		151	197	243	289	335	381	427	473	519	L ₂ = 46 x n + 59

- VV061
- V100
- S070
- VQD
- VKF
- VK
- VT**
- VS

Series VT317

Dimensions: Individual Exhaust

Without mounting bracket/VV317-02-□3-02

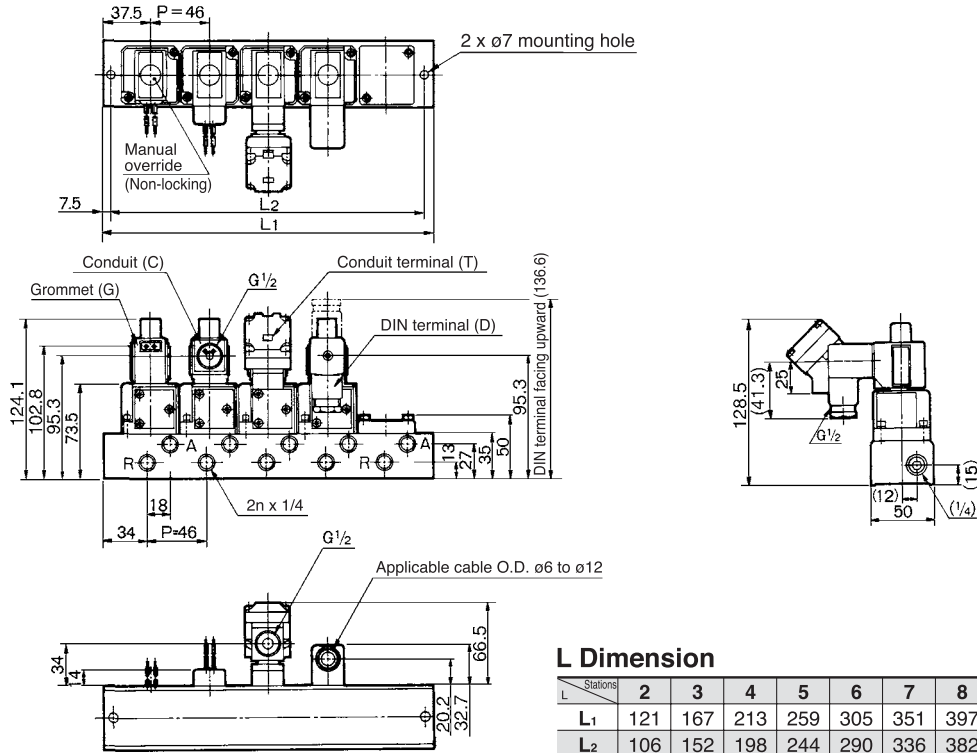

L Dimension										n: Stations
Stations	2	3	4	5	6	7	8	9	10	Formula
L ₁	121	167	213	259	305	351	397	443	489	L ₁ = 46 x n + 29
L ₂	106	152	198	244	290	336	382	428	474	L ₂ = 46 x n + 14

⚠ Precautions

Be sure to read before handling. Refer to front matters 58 and 59 for Safety Instructions and pages 3 to 7 for 3/4/5 Port Solenoid Valve Precautions.

Mounting

⚠ Warning

- When mounting valves on the manifold base, the mounting orientation is decided. If it is mounted in the wrong direction, connected equipment may malfunction. Mount it by referring to how to switch over from N.C. to N.O. specifications.

⚠ Caution

- Each valve is fixed to the manifold base with two M4 mounting screws. Tighten the screws evenly when re-mounting. Tightening torque of the mounting screw (M4): 1.4 N·m
- For mounting, tighten M4 or equivalent screws evenly into the mounting holes of the manifold base.

Changing from N.C. to N.O.

⚠ Caution

Universal porting permits convertibility N.C./N.O. by a simple 180 degree rotation. Mounting conditions for N.C. and N.O. is indicated as below figure.

Exhaust port type	Valve	N.C.	N.O.
Common exhaust			



* Changing from N.C. to N.O.

This product is delivered as N.C. valve. If N.O. valve is needed, remove mounting screws of the required valve and turn the valve at 180° degrees. (Make sure that there are O-rings fixed on 4 positions of the valve surface.) Then, tighten the mounting screws to fix the valve to the manifold base.



Series VT317 Specific Product Precautions

Be sure to read before handling. Refer to Front matters 58 and 59 for Safety Instructions and pages 3 to 7 for 3/4/5 Port Solenoid Valve Precautions.

⚠ Caution

1. A bleed port for the main valve is located at the bottom of the solenoid valve. Since blocking it causes malfunction, do not block it.
* Ordinarily, when the solenoid valve is mounted on a metal surface, it can breathe through the breather hole, via the breather groove. However, in particular, if the surface to be mounted is made of the rubber, the rubber could deform and block the hole.
2. Make sure that dust and/or other foreign materials should not enter the valve from the unused port (e.g. exhaust port). Also, since there is a bleed port for the armature in the manual override, do not allow accumulation of dust and/or other foreign materials to block bleed port.

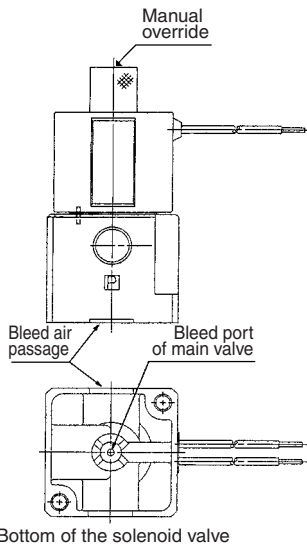

How to Calculate the Flow Rate

For obtaining the flow rate, refer to front matters 44 to 47.

Lead Wire Color (Grommet)

Voltage	Color
100 VAC	Blue
200 VAC	Red
DC	Red (+), Black (-)
Other	Gray

Electrical Connection

DIN terminal is connected inside as in the figure below. Connect to the corresponding power supply.

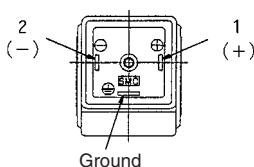

⚠ Caution

Change of Electrical Entry Angle

1. Series VT317 can change electrical entry angle. (4 positions)
2. How to change: Loosen the nut (1), remove the coil (2) from the body assembly (3), place the positioning pin (4) at the required place, put back the coil (2) to its place, and tighten sufficiently with lock nut (1).

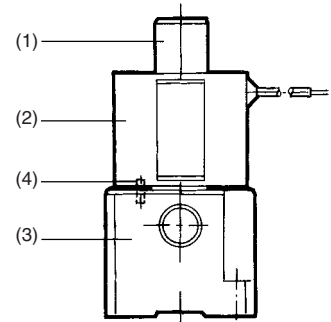

Light/Surge Voltage Suppressor

		Grommet (G) Conduit (C)	Conduit terminal (T) DIN terminal (D)
Surge voltage suppressor (S)	AC		
	DC		
Light/Surge voltage suppressor (Z)	AC	None	
	DC		<div style="display: flex; justify-content: space-around;"> <div> <p>48 VDC or less</p> </div> <div> <p>100 VDC</p> </div> </div>

⦿ Protection circuit for light/surge voltage suppressor is not the polarity type.

VV061

V100

S070

VQD

VKF

VK

VT

VS

How to Use DIN Terminal

1. Disassembly

- 1) After loosening the thread (1), then if the cover (4) is pulled in the direction of the thread, the connector will be removed from the body of equipment (solenoid, etc.).
- 2) Pull out the screw (1), then remove the gasket (2a) or (2b).
- 3) On the bottom part of the terminal block (3), there's a cut-off part (indication of an arrow) (3a). If a small flat head screwdriver is inserted between the opening in the bottom, terminal block (3) will be removed from the cover (4). (Refer to graph at right.)
- 4) Remove the cable gland (5) and plain washer (6) and rubber seal (7).

2. Wiring

- 1) Pass them through the cable (8) in the order of cable ground (5), washer (6), rubber seal (7), and then insert into the housing (4).
- 2) Dimensions of the cable (8) are as shown in the right figure. Skin the cable and crimp the crimped terminal (9) to the edges.
- 3) Remove the screw with washer (3e) from the bracket (3e). (Loosen in the case of Y-shape type terminal.) As shown in the right figure, mount a crimped terminal (9), and then again tighten the screw (3e).
Note) Tighten within the tightening torque of 0.5 N·m ±15%.
Note: a It is possible to wire even in the state of bare wire. In that case,

loosen the screw with washer (3e) and place a lead wire into the bracket (3d), and then tighten it once again.

b The maximum size for the round terminal (9) is 1.25 mm²—3.5 and for the Y terminal is 1.25 mm²—4.

c Cable (8) external: $\phi 6$ to $\phi 12$

Note) For the one with the external external dimension ranged between $\phi 9$ to $\phi 12$ remove the inside parts of the rubber seal (7) before using.

3. Assembly

- 1) Terminal box (3) connected with housing (4) should be reinstated. (Push it down until you hear the click sound.)
- 2) Putting rubber seal (7), plain washer (6), in this order into the cable introducing slit on the housing (4), then further tighten the cable gland (5) securely.
- 3) By inserting gasket (2a) or (2b) between the bottom part of the terminal box (3) and a plug on an equipment, screw in (1) on top of the housing (4) and tighten it.

Note) Tighten within the tightening torque of 0.5 N·m ±20%.

Note: The orientation of a connector can be changed arbitrarily, depending on the combination of a housing (4) and a terminal box (3).

Exploded view

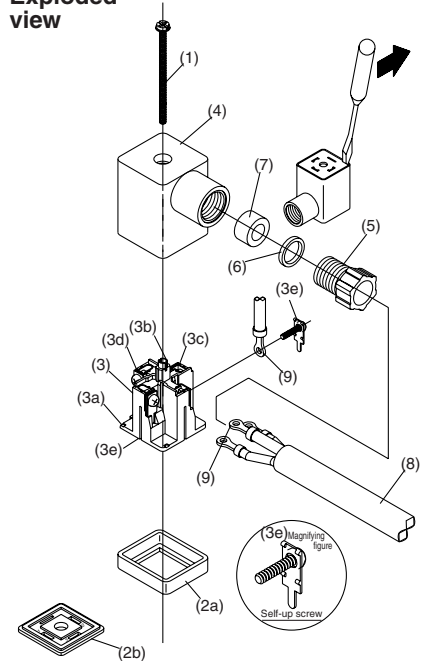

Comparison between the Product Model No. and the Coil Part No.

Product model no.	Coil no.	Coil assembly with terminal part no.
VT/O317□-*G(-02)	PVT317-001GB-**	—
VT/O317□-*GS(-02)	PVT317-*G	—
VT/O317□-*H(-02)	PVT317-001GB-**L06	—
VT/O317□-*HS(-02)	PVT317-*G-06	—
VT/O317□-*C(-02)	PVT317-001CB-**	—
VT/O317□-*CS(-02)	PVT317-*C	—
VT/O317□-*T(-02)	—	PVT317-001TBT-**
VT/O317□-*TS(-02)	—	PVT317-001TBTS-**
VT/O317□-*TZ(-02)	—	PVT317-001TBTZ-**
VT/O317□-*D(-02)	PVT317-001DB-**	PVT317-001DBT-**
VT/O317□-*DS(-02)	PVT317-001DB-**	PVT317-001DBTS-**
VT/O317□-*DZ(-02)	PVT317-001DB-**	PVT317-001DBTZ-**



Note 1) * mark in the product model numbers denotes the rated voltage.

Note 2) □ mark denotes the valve option.

Note 3) * mark and ** mark are for coil part number and coil assembly with terminal the rated voltage.

Example 1) In the case of ** VT317-001GB-05

Example 2) In the case of * PVT317-5G

Note 4) In the case of CE-compliant products (-Q), coils are not shipped together.

⚠ Caution

When the rated voltage is AC and if it is assembled with the coil for DC, response may be delayed and occur malfunction. Also, for DC valves, when the coil for AC is assembled, it occurs malfunction. For AC valves, assemble the coil for AC, and for DC valves, assemble the coil for DC.

Connector for DIN Terminal

Rated voltage	Without light/surge voltage suppressor (D)	With surge voltage suppressor (DS)	Light/Surge voltage suppressor (DZ)
100 VAC	GDM2A	GDM2A-S1	GDM2A-Z1
200 VAC		GDM2A-S2	GDM2A-Z2
24 VDC		GDM2A-S5	GDM2A-Z5

For other rated voltages, please consult with SMC.

3 Port Solenoid Valve Direct Operated Poppet Type Series VT325 Rubber Seal



Compact yet provides a large flow capacity

Dimensions (W x H x D)....55 x 118 x 53
(Grommet)

C: 0.61 dm³/(s·bar)
{Rc 3/8 (Passage 2 → 3)}

A single valve with 6 valve functions

(Universal porting type)

Six valve functions can be attained by selecting the piping ports. (Enabling the N.C. valve, N.O. valve, divider valve, selector valve, etc. to be used as desired.)

Suitable for use in vacuum applications

-101.2 kPa

(For vacuum specifications type: VT/VO325V)



JIS Symbol

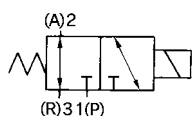

How to Order

VT325 - **02** **1** **G** - - -

For manifold:
Enter "VO".
Valve option

Nil	Standard
V*	For vacuum

* Option

Port size

02	1/4
03	3/8
00	Without connection port (For manifold)

Rated voltage

1	100 VAC, 50/60 Hz
2	200 VAC, 50/60 Hz
3*	110 VAC, 50/60 Hz
4*	220 VAC, 50/60 Hz
5	24 VDC
6*	12 VDC
7*	240 VAC, 50/60 Hz
9*	Other

* Option

Manual override

Nil	Non-locking type
M	Locking type (Tool required)

Thread type

Nil	Rc
F	G
N	NPT
T	NPTF

CE-compliant

Nil	—
Q*	CE-compliant

* Electrical entry:
D/DO/DL/DLO only

Surge voltage suppressor

Nil	None
S	With surge voltage suppressor (AC: Can be attached to Grommet, Conduit, Conduit terminal. DC: Can be attached to Grommet, Conduit, Conduit terminal.)

Electrical entry

G	Grommet, Lead wire length 300 mm
C	Conduit
D	DIN terminal
T	Conduit terminal
TL**	Terminal with indicator light
DL**	DIN terminal with indicator light

** For the coil rated voltage (option *), please contact SMC.

- VV061
- V100
- S070
- VQD
- VKF
- VK
- VT
- VS

Manifold

Model	Applicable manifold	Accessory
VO325-00□□(-Q)	B mount common exhaust type	Gasket (DXT083-13-1) Bolts (DXT083-19-1, 2 pcs.)

Specifications

Type of actuation	Direct operated type 2 position single solenoid
Fluid	Air
Operating pressure range	0 to 1.0 MPa
Ambient and fluid temperature	5 to 50°C
Max. operating frequency	5 Hz
Response time (1)	30 ms or less (at the pressure of 0.5 MPa)
Lubrication	Not required (Use turbine oil Class 1 ISO VG32, if lubricated.)
Manual override	Non-locking push type
Shock/Vibration resistance (2)	150/50 m/s ²
Enclosure	Dustproof



Note 1) Based on dynamic performance test, JIS B 8374-1981. (Coil temperature: 20°C, at rated voltage, without surge suppressor)

Note 2) Impact resistance: No malfunction occurred when it is tested with a drop tester in the axial direction and at the right angles to the main valve and armature in both energized and de-energized states every once for each condition. (Values at the initial period)

Vibration resistance: No malfunction occurred in a one-sweep test between 45 and 1000 Hz. Test was performed at both energized and de-energized states in the axial direction and at the right angles to the main valve and armature. (Values at the initial period)

Solenoid Specifications

Electrical entry	Grommet, Conduit, DIN terminal, Conduit terminal		
Coil rated voltage	100, 200 VAC, 50/60 Hz, 24 VDC		
Allowable voltage fluctuation	-15 to +10% of rated voltage		
Apparent power (3)	AC	Inrush	50 Hz: 75 VA 60 Hz: 60 VA
		Holding	50 Hz: 27 VA 60 Hz: 17 VA
	DC	Power consumption (3): 12 W	



Note 3) At rated voltage

Series VT325

Flow Characteristics/Mass

Valve model	Port size	Flow characteristics												Mass
		1 → 2 (P → A)			2 → 3 (A → R)			3 → 2 (R → A)			2 → 1 (A → P)			
		C [dm ³ /(s·bar)]	b	Cv	C [dm ³ /(s·bar)]	b	Cv	C [dm ³ /(s·bar)]	b	Cv	C [dm ³ /(s·bar)]	b	Cv	
VT325	1/4	5.5	0.37	1.4	5.9	0.35	1.5	5.5	0.33	1.4	5.7	0.32	1.4	0.55 kg (For AC) 0.60 kg (For DC)
VT325V (Vacuum spec. type)		5.5	0.37	1.4	6.1	0.37	1.6	5.7	0.34	1.4	6.6	0.25	1.5	
VT325	3/8	5.5	0.37	1.4	6.1	0.37	1.6	5.7	0.34	1.4	6.6	0.25	1.5	0.55 kg (For AC) 0.60 kg (For DC)
VT325V (Vacuum spec. type)		5.5	0.37	1.4	6.1	0.37	1.6	5.7	0.34	1.4	6.6	0.25	1.5	

Note) Values for a single valve unit. It differs in the manifold case. Refer to manifold specifications on page 1620.

Option

1. For vacuum

Pressure range -101.2 kPa to 0.1 MPa

This vacuum model has less air leakage than the standard model under low pressure. It is recommended for vacuum application.

⚠ Caution

1) Since this valve has slight air leakage, it can not be used for holding vacuum (including positive pressure holding) in the pressure container.

2. With surge voltage suppressor, with indicator light

Surge Voltage Suppressor

	AC	DC
Grommet (GS)		
Conduit (CS)		
Conduit terminal (TS)		

Circuit for Indicator Light

	AC	DC
DIN terminal with indicator light (DL)		
Conduit terminal with indicator light (TL)		

· Grommet type

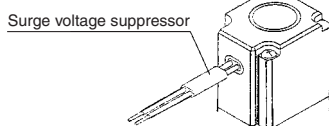

3. Manual override with lock

- Using a screwdriver, push the manual override button that is located in the head portion of the solenoid valve in order to directly push the spool valve downward, thus causing the valve to switch.
- With the button remaining pushed down, turn it approximately 90° clockwise or counterclockwise to maintain the manual override locked state.
- To revert to the original state, keep the button pushed down and turn it approximately 90° clockwise.

Construction

De-energized

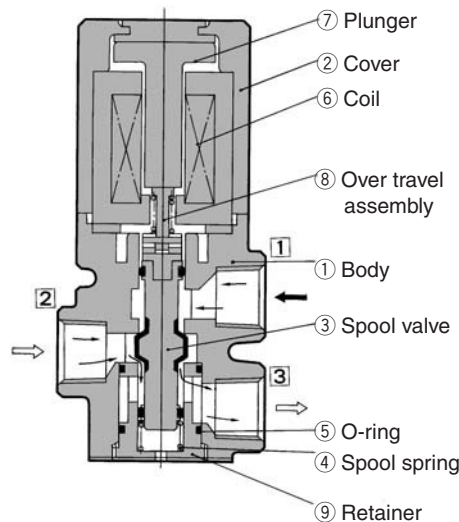

Energized

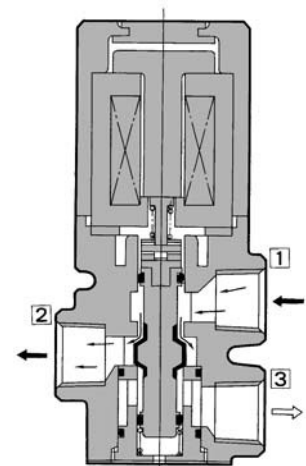

Operation principle

<De-energized>

The spool (3) is pushed upward by the force of the spring (4) and the air passage between port (2) and port (3) is opened and port (1) is blocked.

Air flow direction: 1 ↔ Block, 2 ↔ 3

<Energized>

When the coil (6) is energized the plunger (7) is pulled down depressing the spool (3) via the overtravel assembly (8) and the air passage between port (1) and port (2) is opened and port (3) is blocked.

Air flow direction: 1 ↔ 2, 3 ↔ Block

Component Parts

No.	Description	Material	Note
1	Body	Aluminum die-casted	Platinum silver
2	Cover	Aluminum die-casted	Platinum silver
3	Spool valve	Aluminum, NBR	

Dimensions

Grommet (G)

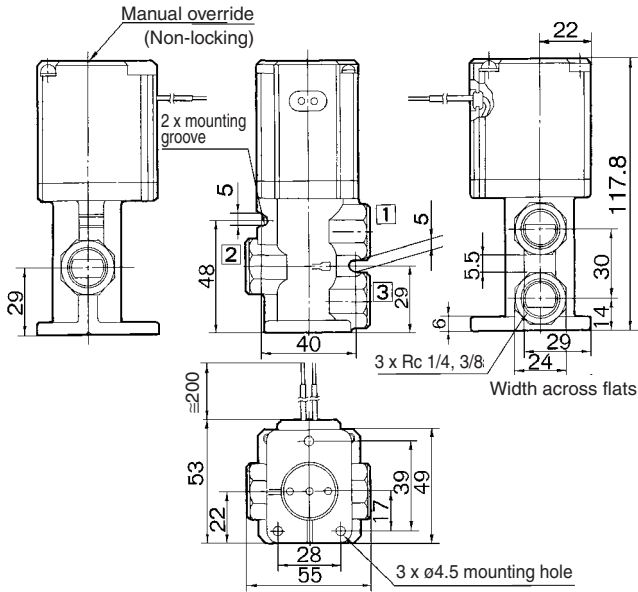

Conduit (C)

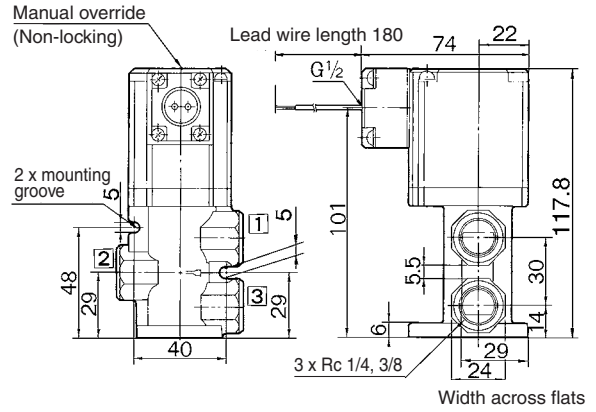

DIN terminal (D)

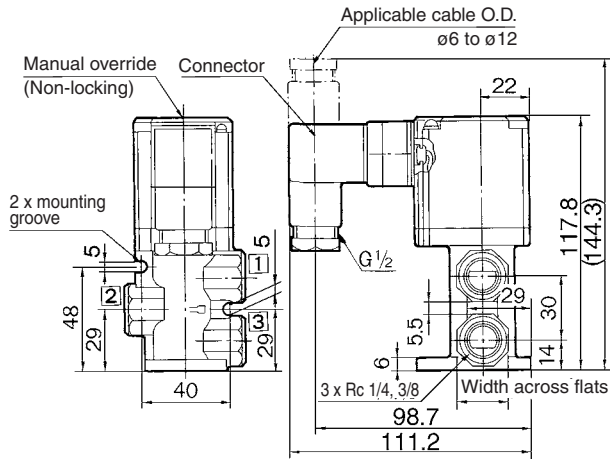

Conduit terminal (T)

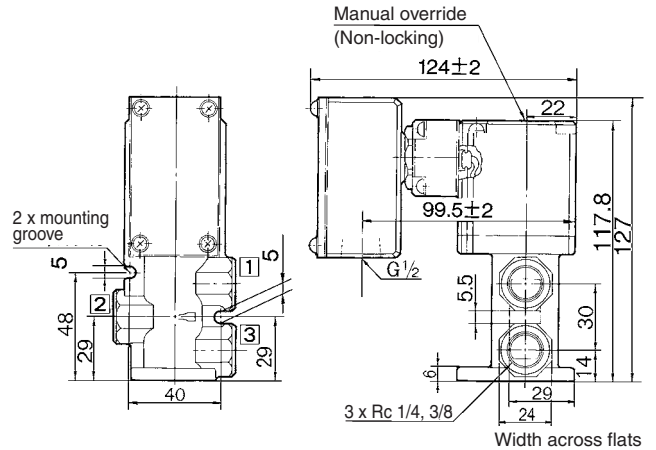

With locking manual override

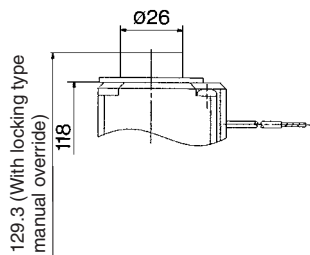

Conduit terminal with indicator light (TL)

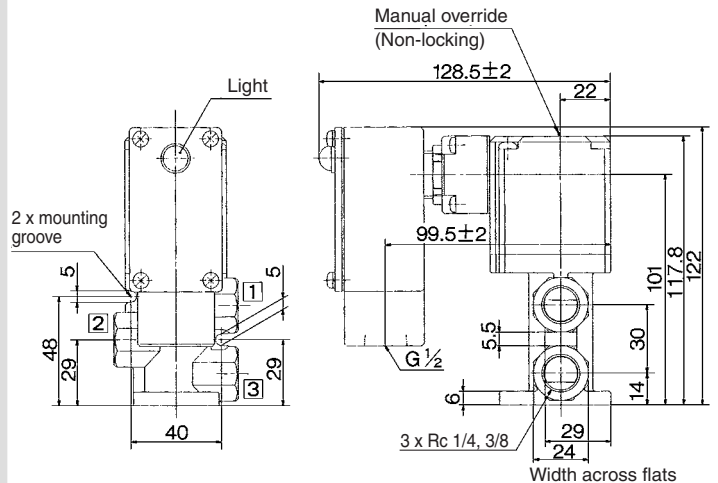

- VV061
- V100
- S070
- VQD
- VKF
- VK
- VT**
- VS

Series VT325

Manifold Specifications

Series VT325 Manifold Model has a B mount style with common exhaust.

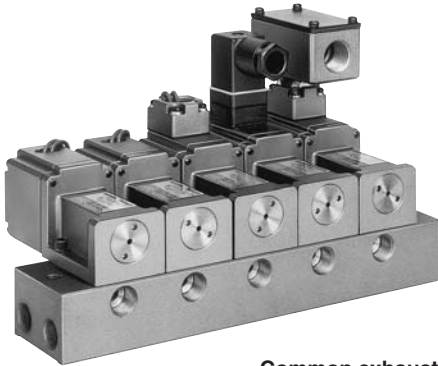

Common exhaust

How to Order Manifold

VVT34 **0** - **05** **1** - **□** **□**

Porting specifications

Symbol	P	A	R
0	Side	Side	Side
1	Side	Bottom	Side

Valve stations

02	2 stations
⋮	⋮
17	17 stations

Port size

Symbol	Port size
02	1/4
03	3/8

Thread type

Nil	Rc
F	G
N	NPT
T	NPTF

Exhaust port type

1	Common exhaust
---	----------------

* Instruct by specifying the valves and blanking plate to be mounted on the manifold along with the manifold base model no.
<Example>
VVT340-051..... 1 pc.
VO325-001G..... 4 pcs.
DXT083-21A..... 1 pc.

Manifold Specifications

Manifold type	B mount					
Max. number of stations	17 stations ^{Note)}					
Applicable solenoid valve	VO325-00□□(-Q)					
Exhaust port type	Port location/Port size			Port direction		
	P	A	R	P	A	R
Common	Base	Base	Base	Side	Side/Bottom	Side
	1/4, 3/8	1/4, 3/8	1/4, 3/8			
Option	Blanking plate (With gasket, screw)				DXT083-21A	



Note) If there are more than 4 stations, supply air from both P ports and exhaust from both R ports.

Accessory for Applicable

Description	Part no.	Qty.
Manifold gasket	DXT083-13-1	1 pc.
Hexagon socket head screw	DXT083-19-1	2 pcs.

Flow Characteristics/Mass

Valve model	Flow characteristics												Mass
	1 → 2 (P → A)			2 → 3 (A → R)			3 → 2 (R → A)			2 → 1 (A → P)			
	C [dm ³ /(s·bar)]	b	Cv	C [dm ³ /(s·bar)]	b	Cv	C [dm ³ /(s·bar)]	b	Cv	C [dm ³ /(s·bar)]	b	Cv	
VO325	4.1	0.24	1.0	4.4	0.18	1.0	4.5	0.15	1.0	4.3	0.23	1.0	0.58 kg (For AC)
VO325V (Vacuum spec. type)													0.63 kg (For DC)

⚠ Precautions

⚠ Warning

When mounting valves on the manifold base, the mounting orientation is decided. If it is mounted in the wrong direction, connected equipment may malfunction. Mount it by referring to external dimensions on page 1621. Besides, the external dimensions are showing the case of N.C. specifications.

⚠ Caution

Changing from N.C. to N.O.

The valves are assembled as N.C. valves at the time of shipment.

By removing the two retaining screws from the desired valves, and rotating each valve body 180° and reassembling it on the manifold base, it is possible to reassemble an N.C. valve as an N.O. valve. (When doing so, make sure that a gasket is attached to the mounting surface of the valve.) Properly tighten the screws.

The tightening torque of the retaining screws is 3 N·m.

3 Port Solenoid Valve Direct Operated Poppet Type **Series VT325**

Dimensions

Common exhaust

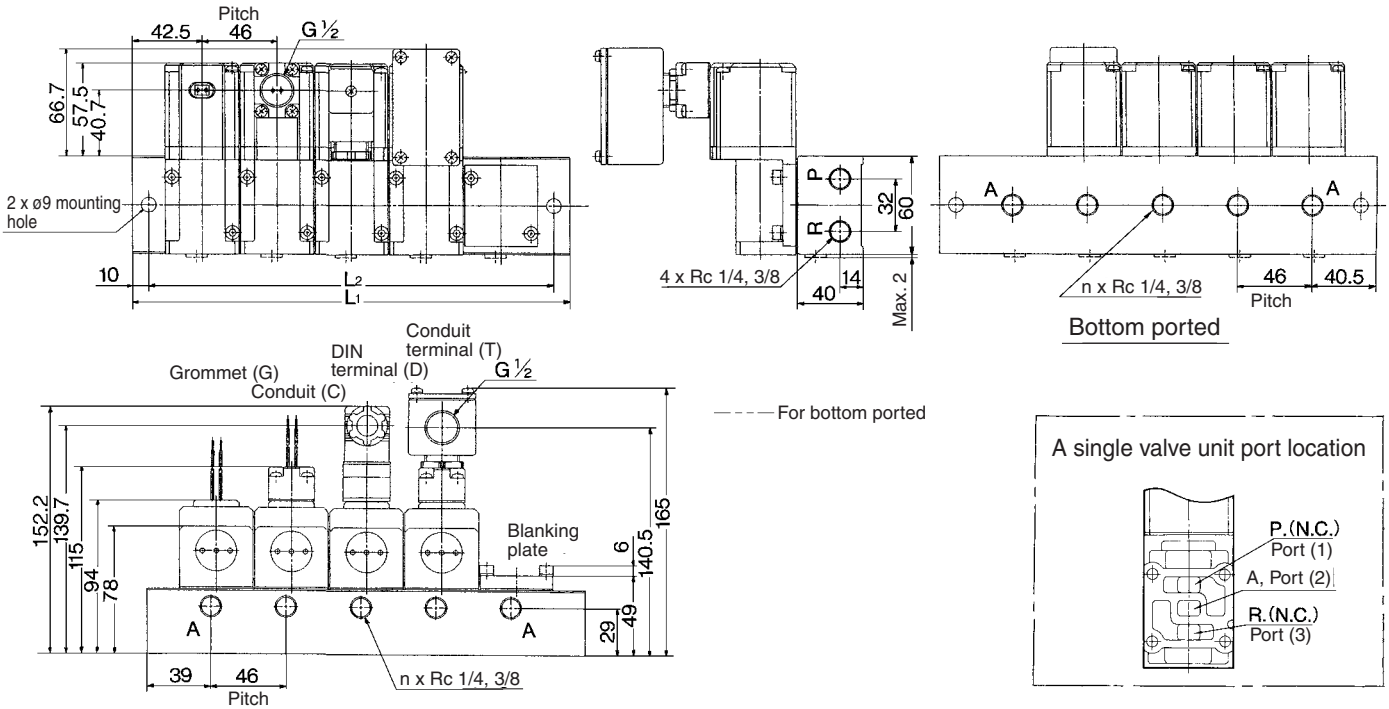

n: Stations

Symbol \ n	2	3	4	5	6	7	8	9	10
L1	131	177	223	269	315	361	407	453	499
L2	111	157	203	249	295	341	387	433	479

Formula: $L1 = 46n + 39$, $L2 = 46n + 19$

VV061

V100

S070

VQD

VKF

VK

VT

VS



Series VT325 Specific Product Precautions

Be sure to read before handling. Refer to front matters 58 and 59 for Safety Instructions and pages 3 to 7 for 3/4/5 Port Solenoid Valve Precautions.

⚠ Caution

- The bottom of the solenoid valve has a breather hole for the main valve. Take proper measures to prevent this hole from being blocked as this will lead to a malfunction.
- Ordinarily, when the solenoid valve is mounted on a metal surface, it can breathe through the breather hole, via the breather groove. However, in particular, if the surface to be mounted is made of the rubber, the rubber could deform and block the hole.

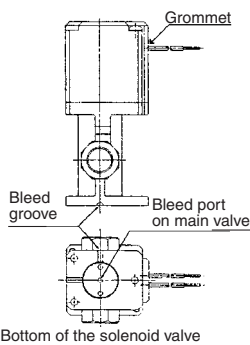

- Make sure that dust and/or other foreign materials do not enter the valve from the unused port (e.g. exhaust port). The grommet portion contains a breather hole for the core. Take proper measures to prevent dust or foreign matter from accumulating in this area.

Electrical Connection

For wiring to DIN terminal, connect the positive (+) polar side with connector terminal no. 1 and the negative (-) side with connector terminal no. 2 when the rated voltage is DC type.

How to Calculate the Flow Rate

For obtaining the flow rate, refer to front matters 44 to 47.

How to Wire DIN Terminal

1. Disassembly

- After loosening the thread (1), then if the cover (4) is pulled in the direction of the thread, the connector will be removed from the body of equipment (solenoid, etc.).
- Pull the screw (1), and then remove gasket (2a) or (2b).
- On the bottom part of the terminal block (3), there's a cut-off part (indication of an arrow) (3a). If a small flat head screwdriver is inserted between the opening in the bottom, terminal block (3) will be removed from the cover (4). (Refer to the figure below.)
- Remove the cable gland (5) and plain washer (6) and rubber seal (7).

2. Wiring

- Pass them through the cable (8) in the order of cable ground (5), washer (6), rubber seal (7), and then insert into the housing (4).
- Dimensions of the cable (8) are the figure as below. Skin the cable and crimp the crimped terminal (9) to the edges.
- Remove the screw with washer (3e) from the bracket (3e). (Loosen in the case of Y shape type terminal.) As shown in the below figure, mount a crimped terminal (9), and then again tighten the screw (3e).

Note) Tighten within the tightening torque of 0.5 N·m \pm 15%.

Note: a It is possible to wire even in the state of bare wire. In that case, loosen the screw with washer (3e) and place a lead wire into the bracket (3d), and then tighten it once again.

b The maximum size for the round terminal (9) is 1.25 mm²—3.5 and for the Y terminal is 1.25 mm²—4.

c Cable (8) external: ϕ 6 to ϕ 12

Note) For the one with the external dimension ranged between ϕ 9 to ϕ 12 remove the inside parts of the rubber seal (7) before using.

3. Assembly

- Terminal box (3) connected with housing (4) should be reinstated. (Push it down until you hear the click sound.)
- Putting rubber seal (7), plain washer (6), in this order into the cable introducing slit on the housing (4), then further tighten the cable gland (5) securely.
- By inserting gasket (2a) or (2b) between the bottom part of the terminal box (3) and a plug on an equipment, screw in (1) on top of the housing (4) and tighten it.

Note) Tighten within the tightening torque of 0.5 N·m \pm 20%.

Note: The orientation of a connector can be changed arbitrarily, depending on the combination of a housing (4) and a terminal box (3).

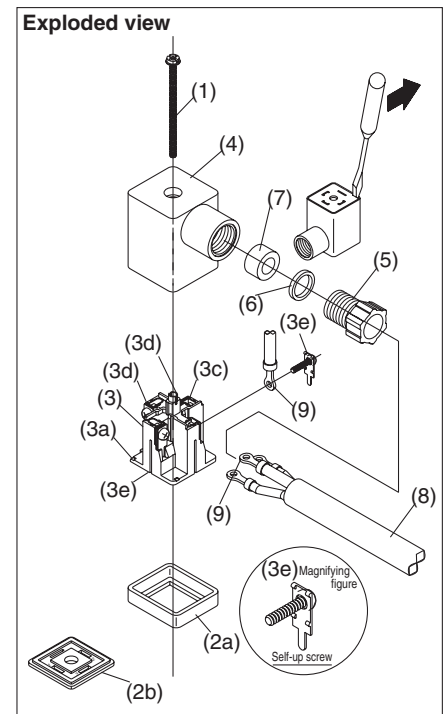

Connector for DIN Terminal

Description	Part no.
DIN connector	GDM2C