

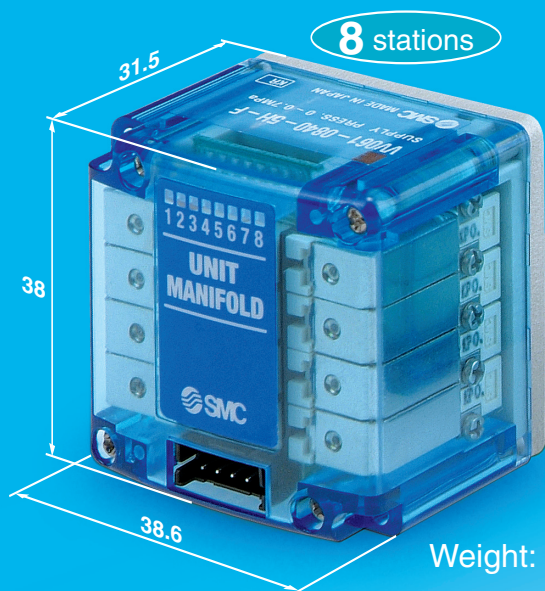

Unit Manifold Valve

Compact Direct Operated 3 Port Solenoid Valve



* When a bracket is not included, barb fittings are included.

6 mm width valve
Mounting the V060 series

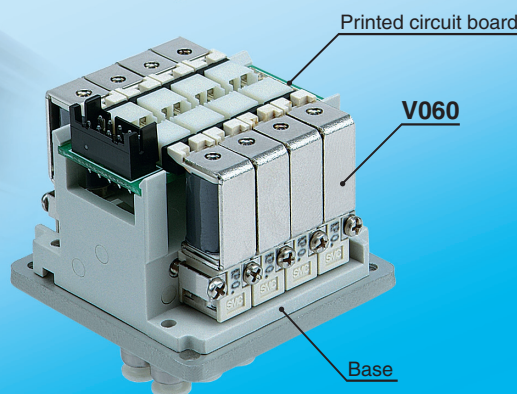
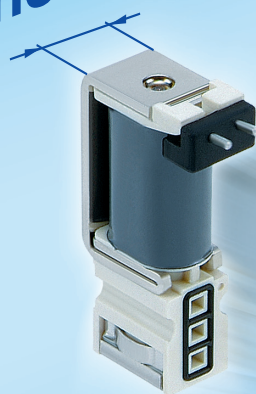

* Photo shown depicts an 8-station unit manifold.

Valve, PCB, base and fittings are fully integrated, forming a single compact unit. New concept unit manifold

Series **VV061**

Unit Manifold

One-touch fitting and barb fitting can be selected.

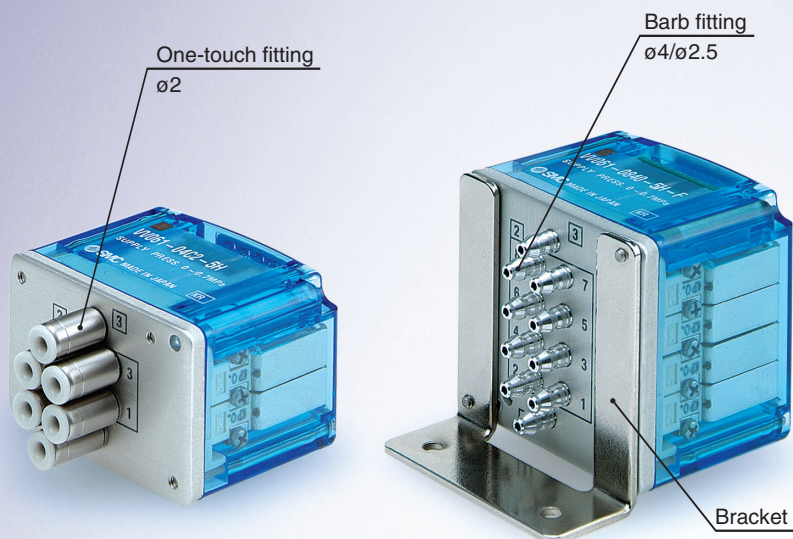

Mounting

- Bracket mount
- Panel mount

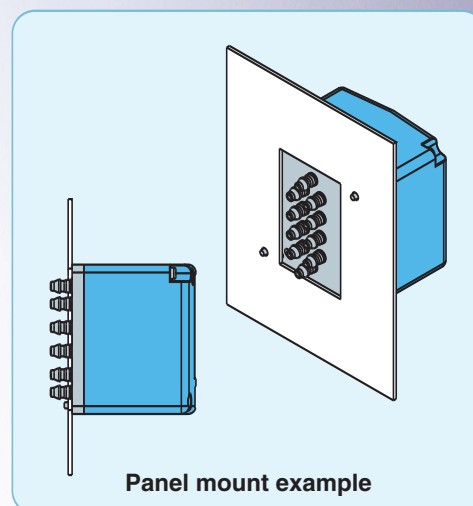

Lead wire length

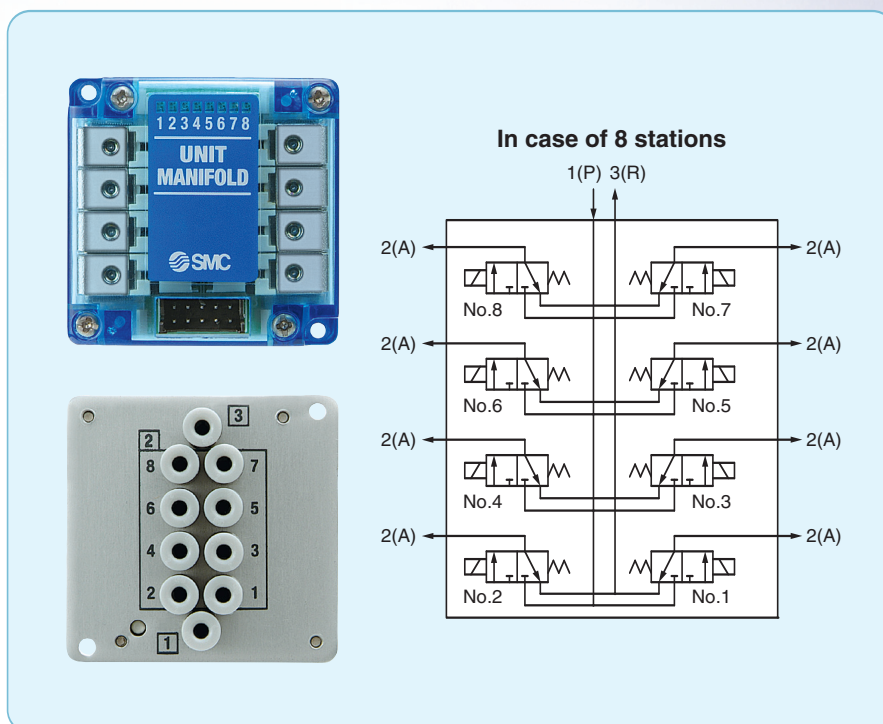
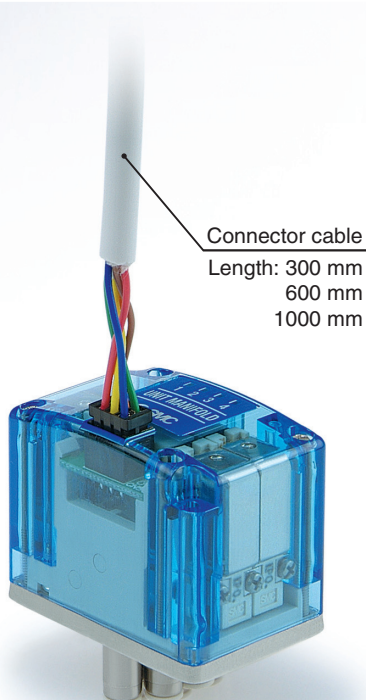

Reduced environmental impact substance RoHS compliant

Unit Manifold Valve

Compact Direct Operated 3 Port Solenoid Valve

Series VV061



How to Order

VV061-08 40-5 H

Valve stations

Symbol	Stations
04	4 stations
08	8 stations

1/2/3 port size

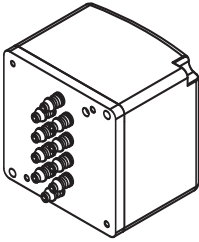
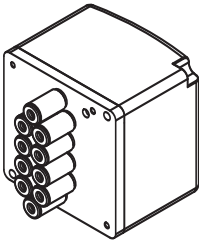
Symbol	Port size
40	Barb fitting (Applicable tubing $\phi 4/\phi 2.5$) 
C2	$\phi 2$ one-touch fitting 

Note) The applicable tube of the barb fitting shows the tube outside diameter/inside diameter.

Rated voltage

5	24 VDC
6	12 VDC

Coil specifications

Nil	Standard (With light/surge voltage suppressor)
T	With power-saving circuit (Continuous duty type)

If the coil will be continuously energized for a long period, be sure to choose the coil with power-saving circuit. (See the back page 2 for details.)

Note 1) Both the standard coil and the coil with power-saving circuit have light/surge voltage suppressor.

Note 2) The wiring specification is positive common only.

Bracket

Nil: Without bracket
(2 mounting screws M2 x 27 are included.)

F: With bracket

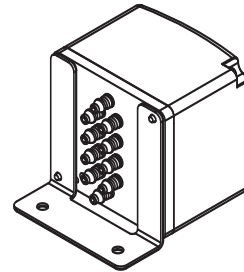

Connector cable

Nil: Without connector cable

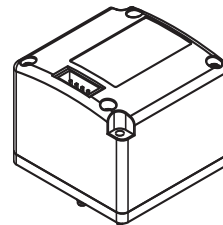

C1: With connector cable (Length 300 mm)
C2: With connector cable (Length 600 mm)
C3: With connector cable (Length 1000 mm)

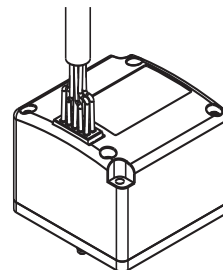

Operating pressure range

H	Standard (0 to 0.7 MPa)
L	High flow type (0 to 0.3 MPa)

Series VV061

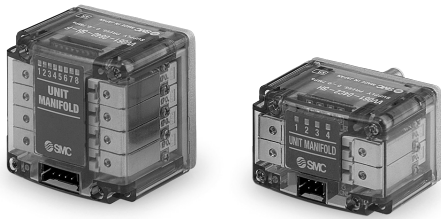

Unit Manifold Specifications

Fluid		Air	
Operating pressure range (MPa)	Standard	0 to 0.7	
	High flow type	0 to 0.3	
Vacuum specification (MPa)	Standard	1(P) port	3(R) port
		-100 kPa to 0.6	-100 kPa to 0
Vacuum specification (MPa)	High flow type	-100 kPa to 0.2	-100 kPa to 0
	Ambient and fluid temperature (°C)		
Response speed (ms) ^{Note 1)}			10 ms or less
Max. operating frequency (Hz)			20
Lubrication			Not required
Mounting orientation			Unrestricted
Impact/Vibration resistance (m/s²) ^{Note 2)}			150/30
Enclosure			Dustproof

Note 1) Based on dynamic performance test, JIS B8374-1981. (Standard type: Coil temperature 20°C, at rated voltage.)

Note 2) Impact resistance: No malfunction occurred when it is tested with a drop tester in the axial direction and at the right angles to the main valve and armature in both energized and de-energized states every once for each condition. (Value in the initial state)

Vibration resistance: No malfunction occurred in one sweep test between 45 and 2000 Hz. Test was performed to axis and right angle directions of the main valve and armature when pilot signal is ON and OFF. (Value in the initial state)

The impact/vibration resistance is 50/10 [m/s²] for the manifold with a power-saving circuit (0.23 W).

Symbol

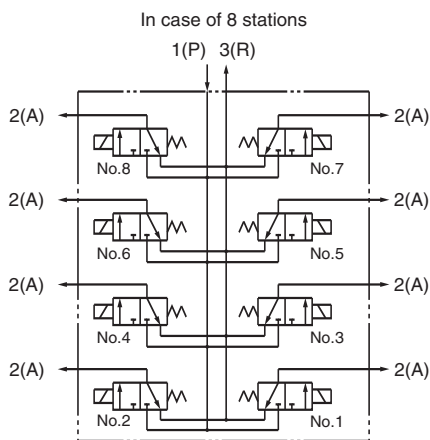
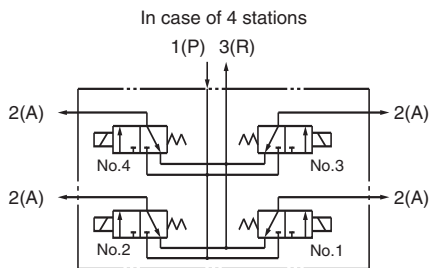

Solenoid Specifications

Coil rated voltage	12, 24 VDC	
Allowable voltage fluctuation ^{Note)}	Standard	24 VDC
	Power-saving type	12 VDC
Power consumption (W)	Standard: 0.55	
	With power-saving circuit (Continuous duty type): 0.23	
Surge voltage suppressor	Diode	
Indicator light	LED	

Note) The voltage fluctuation should be within the above range because the internal circuit can cause voltage drop.

Flow Characteristics

Type	Effective area (mm ²)	
	1(P)→2(A)	2(A)→3(R)
Standard	0.07	0.11
High flow type	0.16	0.21

Weight

Stations	Port size	Weight (g) ^{Note)}
4 stations	Barb fitting	47 (56)
	ø2 one-touch fitting	53 (62)
8 stations	Barb fitting	75 (85)
	ø2 one-touch fitting	84 (94)

Note) (): values with bracket

Unit Manifold Internal Wiring

In case of 4 stations

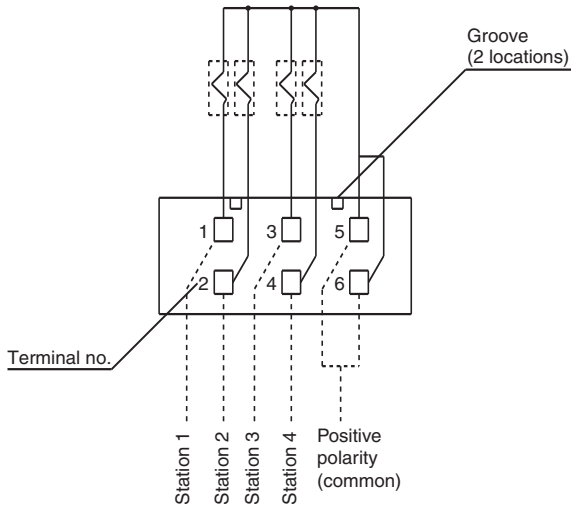

In case of 8 stations

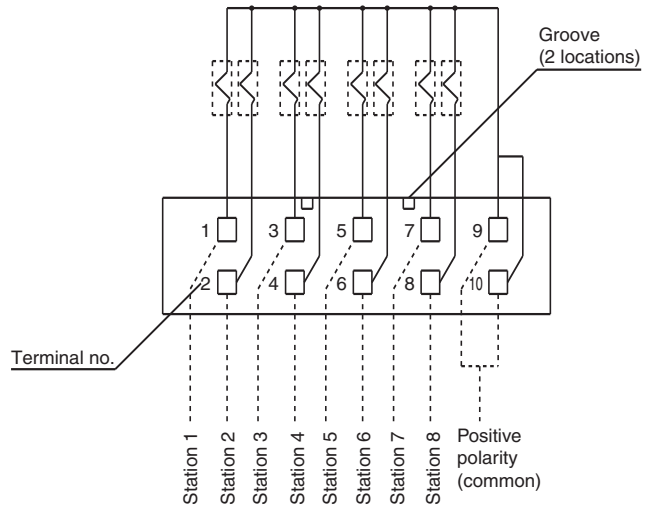

Connector Cable Specifications

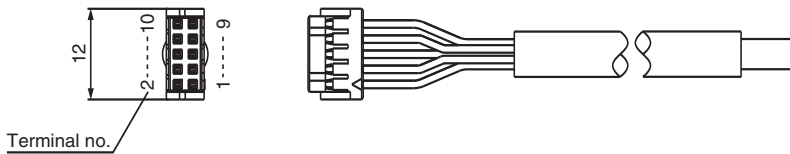

Connector Cable Color List of Each Terminal No.

In case of 4 stations

Terminal no.	Lead wire color
1	Brown
2	Red
3	Orange
4	Yellow
5	Green
6	Blue

In case of 8 stations

Terminal no.	Lead wire color
1	Brown
2	Red
3	Orange
4	Yellow
5	Green
6	Blue
7	Purple
8	Gray
9	White
10	Black

Construction

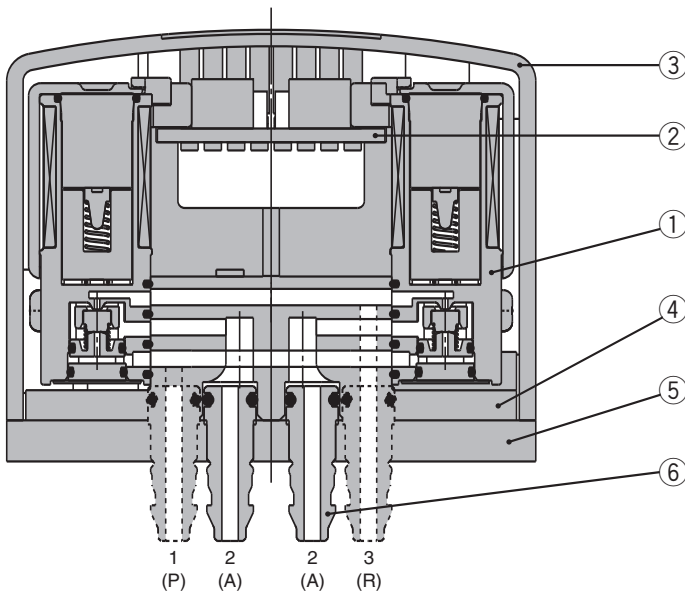

Component Parts

No.	Description	Material	Note
1	Solenoid valve	—	Unit assembly
2	PCB assembly	—	
3	Cover	Resin	(4 mounting screws M2 x 27 L are included.)
4	Base	Resin	
5	Plate	Aluminum	Plate assembly
6	Barb fitting	Aluminum	

Note) As this drawing shows the internal construction, it is different from the actual product.

Series VV061

Replacement Parts

① Unit assembly

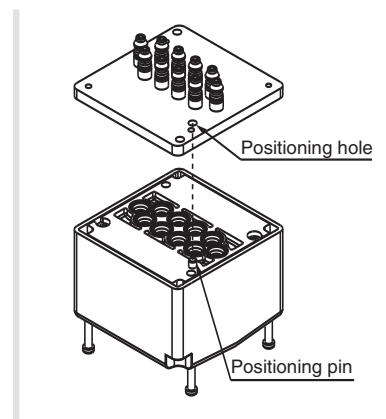
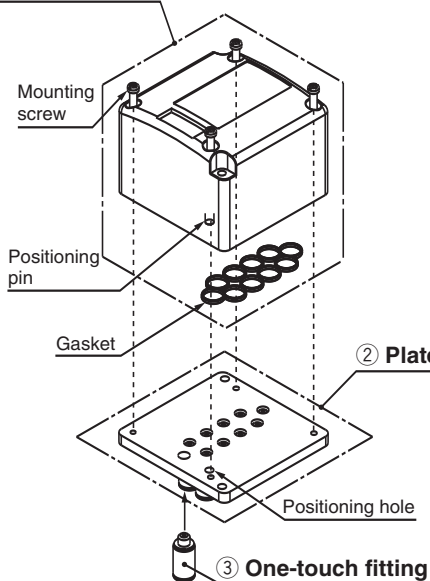

How to Mount Unit Assembly

Fit the positioning pin on the unit assembly to the positioning hole on the plate, and assemble them.

⚠ Caution

Tightening torque: 0.12 N·m

① Unit Assembly Part No.

VV061-08 00-5 H

Valve stations

Symbol	Stations
04	4 stations
08	8 stations

1/2/3 port size

Symbol	Port size
00	Without plate assembly

Rated voltage

5	24 VDC
6	12 VDC

Coil specifications

Nil	Standard (With light/surge voltage suppressor)
T	With power-saving circuit (Continuous duty type)

* If the coil will be continuously energized for a long period, be sure to choose the coil with power-saving circuit.

Operating pressure range

H	Standard (0 to 0.7 MPa)
L	High flow type (0 to 0.3 MPa)

* 4 mounting screws (M2 x 27 L) and one gasket are included.

② Plate Assembly Part No.

Stations	Fitting	Barb fitting	One-touch fitting
4 stations		PV060-10-8A	PV060-10-10A
8 stations		PV060-10-7A	PV060-10-9A
Note		Barb fitting is included.	One-touch fitting is mounted on the plate.

③ Fitting Part No.

If only the fitting is needed, order with one of the part numbers below.

Description	Barb fitting	One-touch fitting
Part no.	PV060-73-1A	KJS02-M3

* The minimum ordering quantity is 10 pcs.

④ Bracket Assembly Part No.

Description	Part no.
Bracket (for 4 stations)	PV060-80-2A (Mounting screw included)
Bracket (for 8 stations)	PV060-80-1A (Mounting screw included)

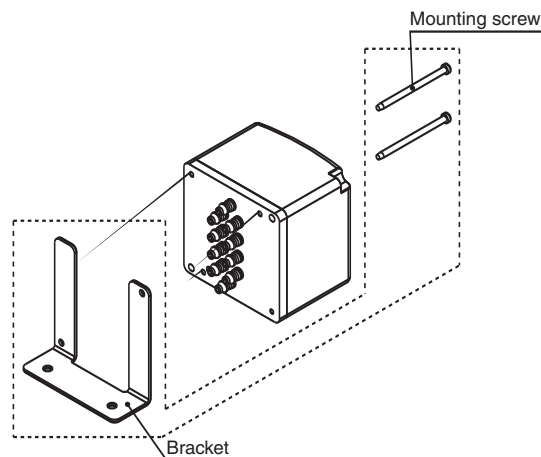

⑤ Connector Cable Part No.

For 4 stations **PV060-40-4A-** []

For 8 stations **PV060-40-3A-** []

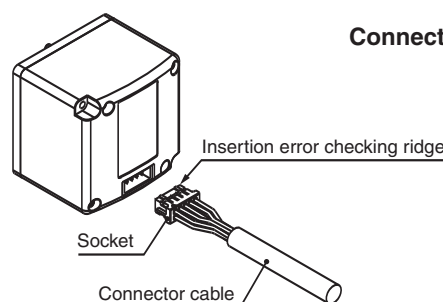

Connector cable length

Nil	300 mm
6	600 mm
10	1000 mm

Dimensions

VV061-04

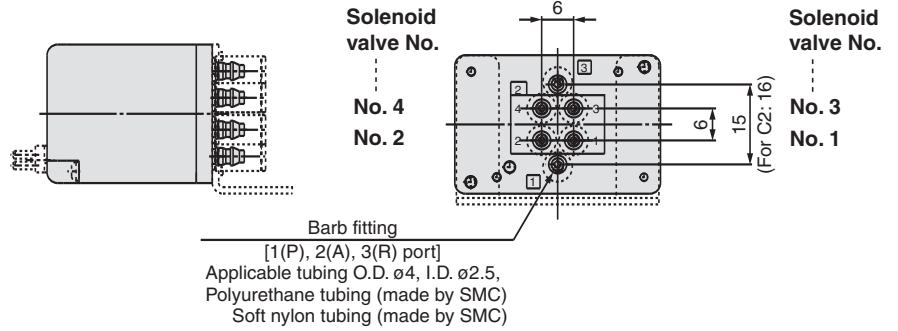
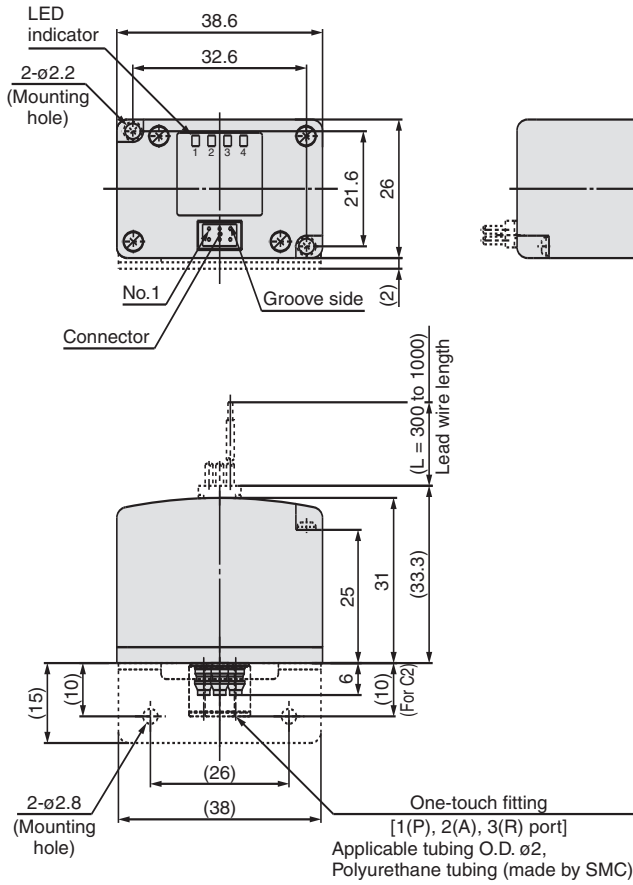

Cut dimension for panel mount (mounting surface)

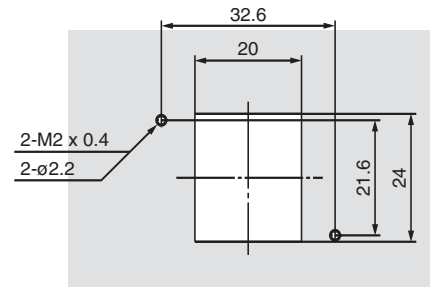

VV061-08

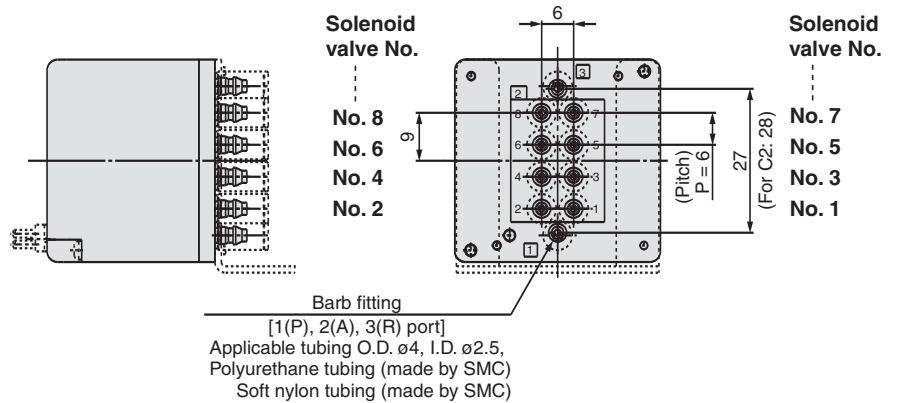
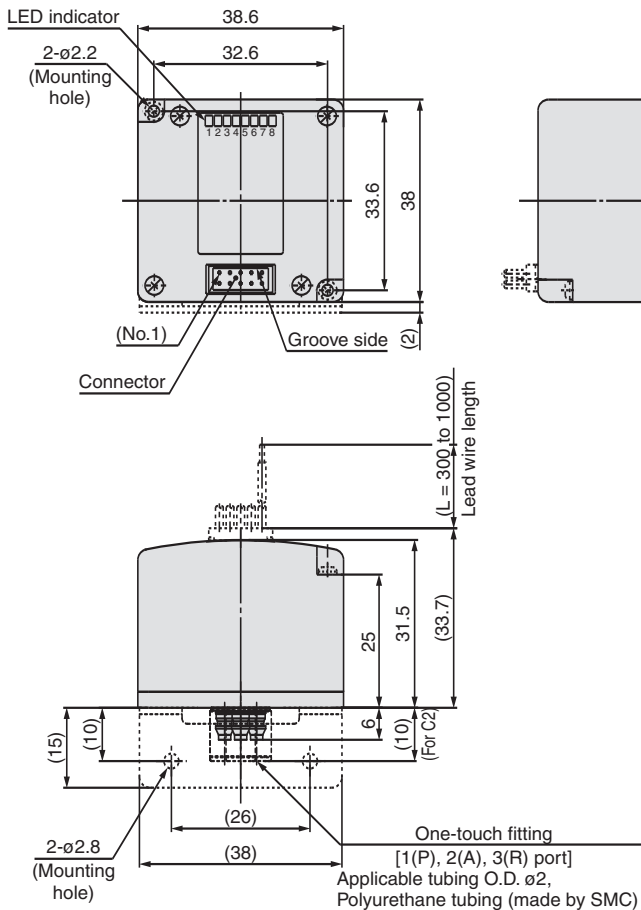

Cut dimension for panel mount (mounting surface)

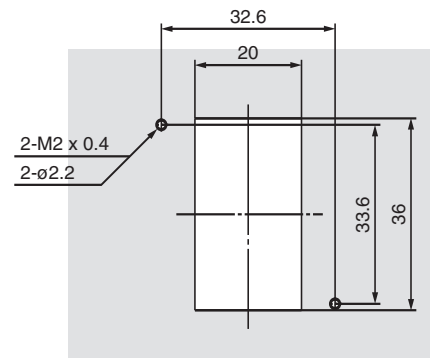





Series VV061

Safety Instructions

These safety instructions are intended to prevent a hazardous situation and/or equipment damage. These instructions indicate the level of potential hazard by labels of "Caution", "Warning" or "Danger". To ensure safety, be sure to observe ISO 4414 ^{Note 1)}, JIS B 8370 ^{Note 2)} and other safety practices.

■ Explanation of the Labels

Labels	Explanation of the labels
 Danger	In extreme conditions, there is a possible result of serious injury or loss of life.
 Warning	Operator error could result in serious injury or loss of life.
 Caution	Operator error could result in injury ^{Note 3)} or equipment damage. ^{Note 4)}

Note 1) ISO 4414: Pneumatic fluid power – General rules relating to systems

Note 2) JIS B 8370: General Rules for Pneumatic Equipment

Note 3) Injury indicates light wounds, burns and electrical shocks that do not require hospitalization or hospital visits for long-term medical treatment.

Note 4) Equipment damage refers to extensive damage to the equipment and surrounding devices.

■ Selection/Handling/Applications

1. The compatibility of the pneumatic equipment is the responsibility of the person who designs the pneumatic system or decides its specifications.

Since the products specified here are used in various operating conditions, their compatibility for the specific pneumatic system must be based on specifications or post analysis and/or tests to meet the specific requirements. The expected performance and safety assurance are the responsibility of the person who has determined the compatibility of the system. This person should continuously review the suitability of all items specified, referring to the latest catalog information with a view to giving due consideration to any possibility of equipment failure when configuring a system.

2. Only trained personnel should operate pneumatically operated machinery and equipment.

Compressed air can be dangerous if handled incorrectly. Assembly, handling or repair of pneumatic systems should be performed by trained and experienced operators. (Understanding JIS B 8370 General Rules for Pneumatic Equipment, and other safety rules are included.)

3. Do not service machinery/equipment or attempt to remove components until safety is confirmed.

1. Inspection and maintenance of machinery/equipment should only be performed once measures to prevent falling or runaway of the driven objects have been confirmed.
2. When equipment is removed, confirm that safety process as mentioned above. Turn off the supply pressure for this equipment and exhaust all residual compressed air in the system, and release all the energy (liquid pressure, spring, condenser, gravity).
3. Before machinery/equipment is restarted, take measures to prevent quick extension of a cylinder piston rod, etc.

4. If the equipment will be used in the following conditions or environment, please contact SMC first and be sure to take all necessary safety precautions.

1. Conditions and environments beyond the given specifications, or if product is used outdoors.
2. Installation on equipment in conjunction with atomic energy, railway, air navigation, vehicles, medical equipment, food and beverages, recreation equipment, emergency stop circuits, clutch and brake circuits in press applications, or safety equipment.
3. An application which has the possibility of having negative effects on people, property, requiring special safety analysis.
4. If the products are used in an interlock circuit, prepare a double interlock style circuit with a mechanical protection function for the prevention of a breakdown. And, examine the devices periodically if they function normally or not.

■ Exemption from Liability

1. SMC, its officers and employees shall be exempted from liability for any loss or damage arising out of earthquakes or fire, action by a third person, accidents, customer error with or without intention, product misuse, and any other damages caused by abnormal operating conditions.

2. SMC, its officers and employees shall be exempted from liability for any direct or indirect loss or damage, including consequential loss or damage, loss of profits, or loss of chance, claims, demands, proceedings, costs, expenses, awards, judgments and any other liability whatsoever including legal costs and expenses, which may be suffered or incurred, whether in tort (including negligence), contract, breach of statutory duty, equity or otherwise.

3. SMC is exempted from liability for any damages caused by operations not contained in the catalogs and/or instruction manuals, and operations outside of the specification range.

4. SMC is exempted from liability for any loss or damage whatsoever caused by malfunctions of its products when combined with other devices or software.



Series VV061

Specific Product Precautions 1

Be sure to read this before handling.

For Safety Instructions, refer to the back of page 1 and for 3/4/5 Port Solenoid Valves and Common Precautions, refer to "Precautions for Handling Pneumatic Devices" (M-03-E3A).

Selection

Warning

1. Extended period of continuous energization

- If a valve will be continuously energized for an extended period of time, the temperature of the valve will increase due to the heat generated by the coil. This will likely adversely affect the performance of the solenoid valve and any nearby peripheral equipment. Therefore, when it is continuously energized or the energized period per day is longer than the de-energized period, use the valves with power-saving circuit.
- For applications such as mounting a valve on a control panel, incorporate measure to limit the heat radiation so that it is within the operating temperature range.

How to Use Plug Connector

Caution

1. Attaching and detaching connectors

- To attach a connector
 - Insert the connector cable to the end of the socket with the insertion error checking ridge facing upward.
 - Then gently pull the connector cable and check that it does not come out.
- To detach a connector
 - Remove the socket from the unit manifold by gripping the socket of the connector cable.
 - If excessive force is applied to the connector cable, the connector may come off. Do not apply a force of 20 N or more to the lead wire.

Connector Cable Length

Caution

1. Standard length is 300 mm, but the following lengths are also available.

How to Order Connector Assembly

For 4 stations PV060-40-4A-□

For 8 stations PV060-40-3A-□

Connector cable length

Nil	300 mm
6	600 mm
10	1000 mm

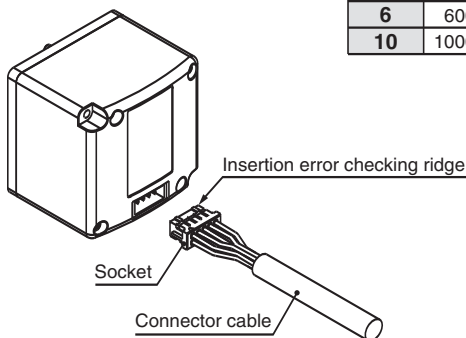

Surge Voltage Suppressor

Caution

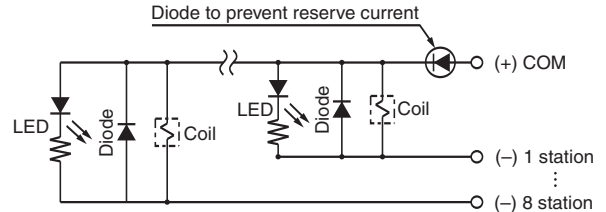

- Since 12 voltage specification does not have diodes for polarity protection, be careful not to make errors in the polarity.
- Please use caution regarding the allowable voltage fluctuation because there is about a 1 volt drop for a valve with polarity protection. (For details, refer to the solenoid specifications for the individual valve.)

With power-saving circuit

Power consumption is decreased by approx. 1/2 by reducing the wattage required to hold the valve in an energized state. (Effective energizing time is over 62 ms.)

Electric circuit (with power-saving circuit) single solenoid

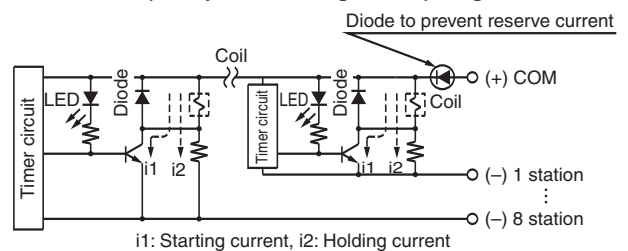

- Impact and vibration should not be more than 50/10 [m/s²].
- Voltage fluctuation for 24 VDC should be within the range of -5% to +10% of the rated voltage, and for 12 VDC should be within the range of -6% to +10% of the rated voltage.

Working Principle

Caution

1. With the above circuit, the current consumption when holding is reduced to save energy. Please

(In case of VV061-□□□□-□T, the electric wave form of power-saving type)

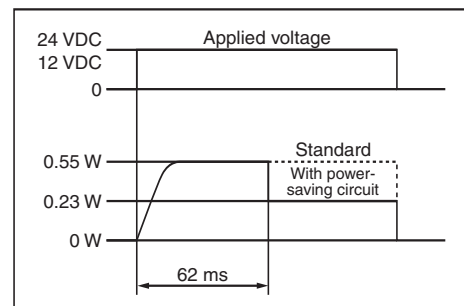

- Please be careful not to reverse the polarity, since a diode to prevent the reversed current is not provided for the 12 VDC specification.
- Please use caution regarding the allowable voltage fluctuation because there is about a 0.5 volt drop due to the transistor.



Series VV061

Specific Product Precautions 2

Be sure to read this before handling.

For Safety Instructions, refer to the back of page 1 and for 3/4/5 Port Solenoid Valves and Common Precautions, refer to “Precautions for Handling Pneumatic Devices” (M-03-E3A).

Mounting

Caution

1. Tightening the threaded portion of an M3 fitting

For KJS02-M3 (one-touch fitting), tighten it with a tightening tool by approx. 1/6 rotation after screwing it in by hand. Screwing the fitting in too far will cause air leakage due to thread breakage and gasket deformation. Screwing the fitting not far enough will also cause air leakage due to the loose screw.

One-touch Fittings Precautions

Caution

1. Tubing insertion and removal from one-touch fittings

1) Attaching of tubing

- (1) Cut the tubing perpendicularly, being careful not to damage the outside surface. Use an SMC tubing cutter “TK-1”, “TK-2” or “TK-3”. Do not cut the tube with pliers, nippers, scissors, etc. If cutting is done with tools other than tube cutters, there is the danger that the tube may be cut diagonally or become flattened, etc., making a secure installation impossible, and causing problems such as the tube pulling out after installation or air leakage. Also allow some extra length in the tube.
- (2) Grasp the tube, slowly push it into the one-touch fittings until it comes to a stop.
- (3) Pull the tubing back gently to make sure it has a positive seal. Insufficient installation may cause air to leak or the tube to release.

2) Removing of tubing

- (1) Push flange evenly and push the release bushing sufficiently.
- (2) Pull out the tube while keeping the release button depressed. If the release bushing is not held down sufficiently, the tube cannot be withdrawn.
- (3) To reuse the tubing, remove the previously lodged portion of the tube. If the lodged portion is left on without being removed, it may result in air leakage and difficulty in removal of the tube.

Other Tubing Brands

Caution

1. When using other than SMC brand tubing, confirm that the following specifications are satisfied with respect to the outside diameter tolerance of the tubing.

- | | |
|------------------------|---|
| 1) Soft nylon tubing | within ± 0.1 mm |
| 2) Polyurethane tubing | within $+0.15$ mm,
within -0.2 mm. |

Do not use tubing which does not meet these outside diameter tolerances. It may not be possible to connect them, or they may cause other trouble, such as air leakage or the tubing pulling out after connection.



SMC'S GLOBAL MANUFACTURING, DISTRIBUTION AND SERVICE NETWORK

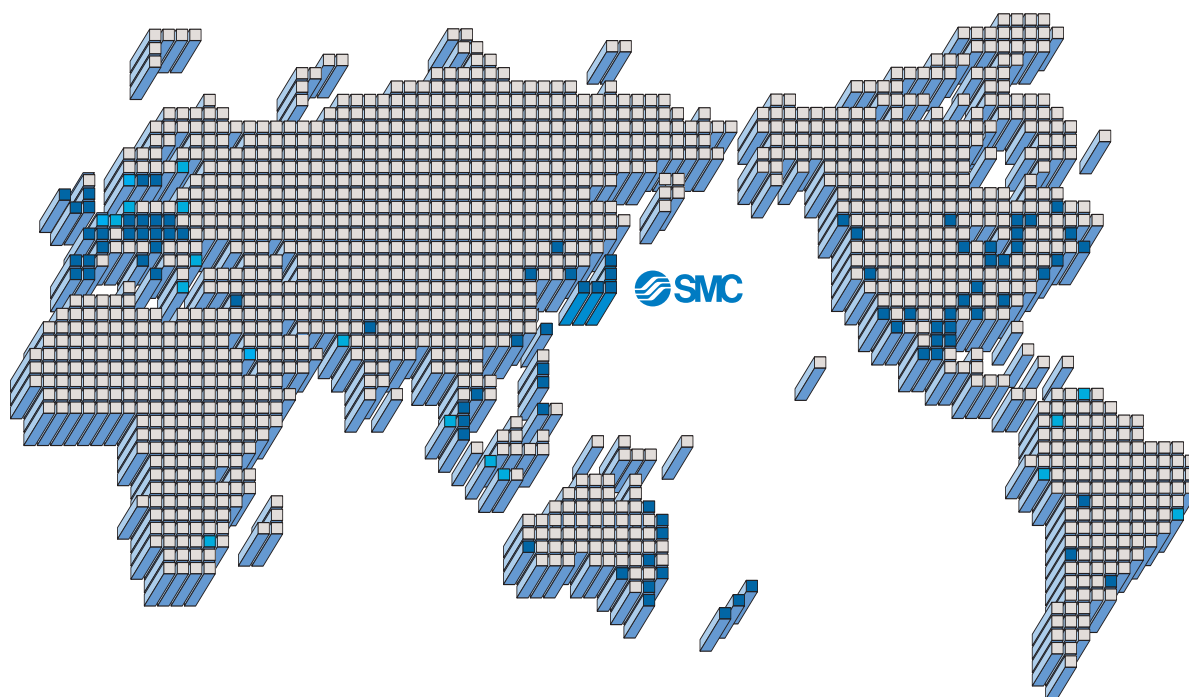

EUROPE

AUSTRIA

SMC Pneumatik GmbH

BELGIUM

SMC Pneumatics N.V./S.A.

BULGARIA

SMC Industrial Automation Bulgaria EOOD

CROATIA

SMC Industrijska automatika d.o.o.

CZECH REPUBLIC

SMC Industrial Automation CZ s.r.o.

DENMARK

SMC Pneumatik A/S

ESTONIA

SMC Pneumatics Estonia OÜ

FINLAND

SMC Pneumatics Finland OY

FRANCE

SMC Pneumatique SA

GERMANY

SMC Pneumatik GmbH

GREECE

SMC Hellas EPE

HUNGARY

SMC Hungary Ipari Automatizálási Kft.

IRELAND

SMC Pneumatics (Ireland) Ltd.

ITALY

SMC Italia S.p.A.

LATVIA

SMC Pneumatics Latvia SIA

LITHUANIA

SMC Pneumatics Lietuva, UAB

NETHERLANDS

SMC Pneumatics BV.

NORWAY

SMC Pneumatics Norway A/S

POLAND

SMC Industrial Automation Polska Sp.z.o.o.

ROMANIA

SMC Romania s.r.l.

RUSSIA

SMC Pneumatik LLC.

SLOVAKIA

SMC Priemyselná automatizácia, s.r.o.

SLOVENIA

SMC INDUSTRIJSKA AVTOMATIKA d.o.o.

SPAIN/PORTUGAL

SMC España, S.A.

SWEDEN

SMC Pneumatics Sweden AB

SWITZERLAND

SMC Pneumatik AG.

UK

SMC Pneumatics (U.K.) Ltd.

ASIA

CHINA

SMC (China) Co., Ltd.

HONG KONG

SMC Pneumatics (Hong Kong) Ltd.

INDIA

SMC Pneumatics (India) Pvt. Ltd.

INDONESIA

PT. SMC Pneumatics Indonesia

MALAYSIA

SMC Pneumatics (S.E.A.) Sdn. Bhd.

PHILIPPINES

SHOKETSU-SMC Corporation

SINGAPORE

SMC Pneumatics (S.E.A.) Pte. Ltd.

SOUTH KOREA

SMC Pneumatics Korea Co., Ltd.

TAIWAN

SMC Pneumatics (Taiwan) Co., Ltd.

THAILAND

SMC Thailand Ltd.

NORTH AMERICA

CANADA

SMC Pneumatics (Canada) Ltd.

MEXICO

SMC Corporation (Mexico) S.A. de C.V.

USA

SMC Corporation of America

SOUTH AMERICA

ARGENTINA

SMC Argentina S.A.

BOLIVIA

SMC Pneumatics Bolivia S.R.L.

BRAZIL

SMC Pneumaticos Do Brazil Ltda.

CHILE

SMC Pneumatics (Chile) S.A.

VENEZUELA

SMC Neumatica Venezuela S.A.

OCEANIA

AUSTRALIA

SMC Pneumatics (Australia) Pty. Ltd.

NEW ZEALAND

SMC Pneumatics (N.Z.) Ltd.



Safety Instructions

Be sure to read "Precautions for Handling Pneumatic Devices" (M-03-E3A) before using.

SMC Corporation

Akihabara UDX 15F,
4-14-1, Sotokanda, Chiyoda-ku, Tokyo 101-0021, JAPAN
Phone: 03-5207-8249 FAX: 03-5298-5362
URL <http://www.smcworld.com>
© 2007 SMC Corporation All Rights Reserved

Specifications are subject to change without prior notice
and any obligation on the part of the manufacturer.

D-DN

1st printing LR printing LR 120DN Printed in Japan.

This catalog is printed on recycled paper with concern for the global environment.