

2/3 Port Valve for Various Fluids Control



■ 2/3 Port Solenoid/Air Operated Valve for Various Fluids Control
(For Water/Air/Oil/Gas/Vacuum/Steam)

□ 2/3 Port Solenoid Valve

- Direct operated 2 port solenoid valve: **VX21/22/23** 17-3-17
- Pilot operated 2 port solenoid valve: **VXD21/22/23** 17-3-33
- Pilot operated 2 port solenoid valve: **VXP21/22/23** 17-3-43
- Water hammer relief, pilot operated 2 port solenoid valve: **VXR21/22/23** ... 17-3-53
- Pilot operated 2 port solenoid valve
for zero pressure differential operation: **VXZ**..... 17-3-61
- Pilot operated 2 port solenoid valve for high pressure: **VXH**..... 17-3-69
- 2 port solenoid valve for dust collector: **VXF**..... 17-3-71
- Direct operated 3 port solenoid valve: **VX31/32/33** 17-3-81

□ 2/3 Port Air Operated Valve

- Direct air operated 2 port valve: **VXA21/22**..... 17-3-93
- Direct air operated 2 port valve: **VXA31/32**..... 17-3-101

The models VX21/22/23 have been revised. For details, please refer to catalog no. ES70-23A.
The models VX31/32/33 have been revised. For details, please refer to catalog no. ES70-26A.
Similar updating for other VX* series are scheduled to follow shortly.

VC□

VDW

VQ

VX2

VX□

VX3

VXA

VN□

LVC

LVA

LVH

LVD

LVQ

LQ

LVN

TI/
TIL

PA

PAX

PB

For Fluid Control 2/3 Port Valve Solenoid Valve/Air Operated Valve For Water, Air, Oil, Gas, Vacuum and Steam

2 Port, Direct Operated

Series VX21/22/23

N.C., N.O./ Single unit, Manifold

Refer to our catalog "ES70-23A".

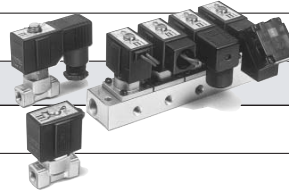

2 Port, Pilot Operated (Diaphragm type)

Series VXD21/22/23

N.C., N.O.

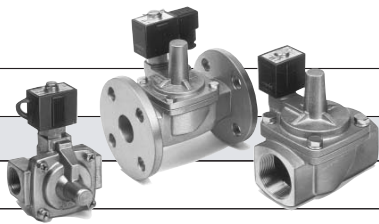
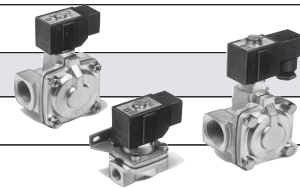

2 Port, Pilot Operated (Disk type)

Series VXP21/22/23

N.C., N.O.

2 Port, Pilot Operated

Series VXR21/22/23

< Water hammer relief > N.C., N.O.

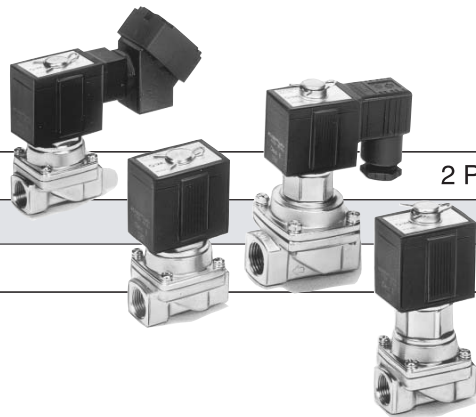
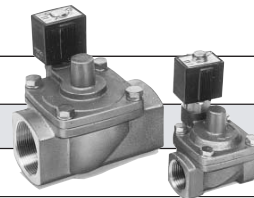

2 Port, Pilot Operated (Diaphragm type, zero pressure differential operation)

Series VXZ22/23

N.C., N.O./ Single unit

The models VX21/22/23 have been revised. For details, please refer to catalog no. ES70-23A.
 The models VX31/32/33 have been revised. For details, please refer to catalog no. ES70-26A.
 Similar updating for other VX* series are scheduled to follow shortly.

Series VX

2 Port, Pilot Operated

Series VXH22

For high pressure control N.C./Single unit

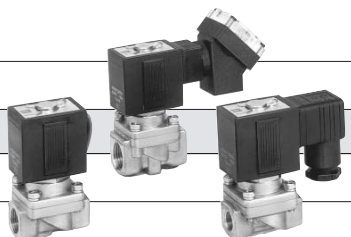

Selection Procedure for 2/3 Port Valve for Fluid Control

1. Selection of the series

Select series by referring to the number of ports, valve type (N.C., N.O., C.O.), port size and applied fluid.

2. Check by the applicable fluids check list



Use the tables on pages 17-3-6 to -14 to check the compatibility of the applicable fluid with the solenoid valve.

3. Confirmation of the working pressure differential

There are two types of pressure differentials. The high pressure differential is the highest pressure difference allowable between the inlet side and the outlet side in an open and closed state. The minimum pressure differential is the lowest pressure required to hold the main valve fully open. Refer to the following pages for each series as the pressure differential varies with the orifice size, power supply, pressure and fluid.

4. Reference to the flow characteristic table

To obtain the flow rate of fluid, refer to the flow characteristic table.

5. Choice of the power supply voltage and electrical entry

Select the AC/DC power source and choose the electrical entry.

VC

VDW

VQ

VX2

VX

VX3

VXA

VN

LVC

LVA

LVH

LVD

LVQ

LQ

LVN

TI/TIL

PA

PAX

PB

2 Port, Pilot Operated

Series VXF21/22

Quick response, Control of instantaneous large flow N.C./Single unit

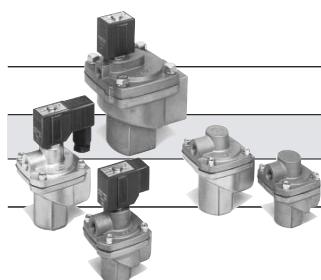

3 Port, Direct Operated

Series VX31/32/33

C.O./Single unit, Manifold

Refer to our catalog "ES70-26A".

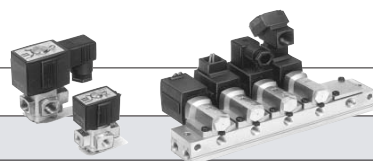

Air Operated Valve

2/3 Port, Direct Operated

Series VXA21/22

Series VXA31/32

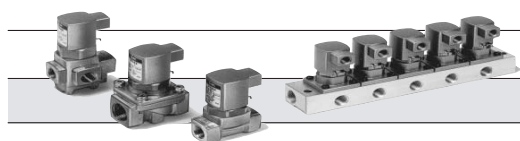

The models VX21/22/23 have been revised. For details, please refer to catalog no. ES70-23A. The models VX31/32/33 have been revised. For details, please refer to catalog no. ES70-26A. Similar updating for other VX* series are scheduled to follow shortly.

Solenoid Valves List

Number of ports		2 port									
Action		Direct operated				Pilot operated Diaphragm type		Pilot operated Disk type		Pilot operated <Water hammer relief>	
Series		VX21/22/23				VXD21/22/23		VXP21/22/23		VXR21/22/23	
Body type		Single unit		Manifold		Single unit		Single unit		Single unit	
Valve type		N.C.	N.O.	N.C.	N.O.	N.C.	N.O.	N.C.	N.O.	N.C.	N.O.
Applicable fluids	Standard	Water	●	—	—	—	●	●	●	●	—
		Air	●	●	●	●	●	●	●	—	—
		Oil	●	●	●	●	●	●	●	●	—
		Low vacuum (1 Torr)	●	●	—	—	—	—	—	—	—
	Option	Steam	●	—	—	—	—	—	●	—	—
		Medium vacuum (10 ⁻³ Torr)	●	●	—	—	—	—	—	—	—
		Non-leak (10 ⁻⁵ atm cc/sec)	●	●	—	—	—	—	—	—	—
	High temperature water, High temperature oil	●	—	—	—	●	●	●	●	—	
Port size	Rc	1/8 (6A)	●	●	—	—	—	—	—	—	—
		1/4 (8A)	●	●	—	—	●	—	—	—	—
		3/8 (10A)	●	●	—	—	●	—	—	—	—
		1/2 (15A)	●	—	—	—	●	●	●	●	●
		3/4 (20A)	—	—	—	—	●	●	●	●	●
	Flange Rc	1 (25A)	—	—	—	—	●	●	●	●	●
		1 1/4 (32A)	—	—	—	—	●	●	●	●	●
		1 1/2 (40A)	—	—	—	—	●	●	●	●	●
		2 (50A)	—	—	—	—	●	●	●	●	●
							Flange	Flange	Flange Rc	Flange Rc	Rc
					Flange	Flange	Flange Rc	Flange Rc	Rc	Rc	
					Flange	Flange	Flange Rc	Flange Rc	Rc	Rc	
					Flange	Flange	Flange Rc	Flange Rc	Rc	Rc	
Page	Catalog ES70-23A				17-3-17		17-3-27		17-3-37		

Air Operated Valves List



* An option is available that sets the orifice in the vacuum side to the maximum bore for exclusive use when used in a vacuum pad application. Refer to page 17-3-86 for details.

Number of ports		2 port				3 port	
Action		Direct operated				Direct operated	
Series		VXA21/22				VXA31/32	
Body type		Single unit		Manifold		Single unit	Manifold
Valve type		N.C.	N.O.	N.C.	N.O.	C.O.	C.O.
Applicable fluids	Standard	Water	●	—	—	●	—
		Air	●	●	●	●	
		Oil	●	●	●	●	
		Low vacuum (1 Torr)	●	●	●	●	
Option	Medium vacuum (10 ⁻³ Torr)	●	●	●	●		
	Non-leak (10 ⁻⁵ atm cc/sec)	●	●	●	●		
Port size	Rc	1/8 (6A)	●	●	—	●	—
		1/4 (8A)	●	●	—	●	—
		3/8 (10A)	●	●	—	●	—
		1/2 (15A)	●	●	—	—	—
Page	17-3-45		17-3-49		17-3-53	17-3-57	

2 port				3 port		
	Pilot operated <Zero pressure differential operation>		Pilot operated <High pressure control>	Pilot operated <Quick response, Instantaneous large flow>		Direct operated
	VXZ22/23		VXH22	VXF21/22	VX31/32/33	
	Single unit		Single unit	Single unit	Single unit	Manifold
	N.C.	N.O.	N.C.	N.C.	N.C./N.O./C.O.	N.C./N.O./C.O.
	●		●	—	●	—
	●		●	●	●	●
	●		●	—	●	●
	●		—	—	●*	●
	—		—	—	●	—
	—		—	—	●	●
	●		—	—	●	—
	—	—	—	—	●	—
	●	●	●	—	●	
	●	●	●	—	●	
	●	●	●	—	—	
	●	●	—	●	—	
	●	●	—	●	—	
	—	—	—	—	—	
	—	—	—	—	—	
	—	—	—	● Rc	—	
	—	—	—	—	—	
	17-3-61		17-3-69	17-3-71	Catalog ES70-26A	

- 

Applicable fluids check list	17-3-6 to 17-3-14
------------------------------	-------------------------

- 

Glossary	17-3-15
----------	---------

- 

How to order Solenoid coil assembly	17-3-16
--	---------

- VC
- VDW
- VQ
- VX2
- VX
- VX3
- VXA
- VN
- LVC
- LVA
- L VH
- LVD
- LVQ
- LQ
- LVN
- TI/
TIL
- PA
- PAX
- PB

⚠ Caution
 Be sure to read before handling. Refer to pages 17-6-3 to 17-6-10 for Safety Instructions and Solenoid Valve Precautions.

Applicable Fluids Check List

Water Hammer Relief/Pilot Operated 2 Port Solenoid Valve Series VXR21/22/23

Normally Closed (N.C.)



Refer to pages 17-3-38 and 17-3-39 for specifications and models.

Option Symbol and Composition

Option symbol	Seal material	Coil insulation type	Body, Shading coil material
Standard	NBR	B	BC6, Copper
A	FKM		
D	FKM	H	

Fluid Name and Option

Fluid (Application)	Option symbol
Heated water (up to 80°C)	D
Fuel oil (up to 60°C)	A
Fuel oil (up to 80°C)	D



* If using for other fluids, please contact SMC.



Normally Open (N.C.)



Refer to pages 17-3-40 and 17-3-41 for specifications and models.

Option Symbol and Composition

Option symbol	Seal material	Coil insulation type	Body, Shading coil material	Holder material (in core assembly)
Standard	NBR	B	BC6, Copper	Polyacetal
A	FKM			
D	FKM	H		Stainless steel

Fluid Name and Option

Fluid (Application)	Option symbol
Heated water (up to 80°C)	D
Fuel oil (up to 60°C)	A
Fuel oil (up to 80°C)	D



* If using for other fluids, please contact SMC.

VC□

VDW

VQ

VX2

VX□

VX3

VXA

VN□

LVC

LVA

LVH

LVD

LVQ

LQ

LVN

TI/
TIL

PA

PAX

PB

Glossary

Pressure

1. Max. operating pressure differential

This pressure difference is the highest pressure difference allowable to operate (a difference between the pressures in the inlet side and the outlet side) in an open state and the closed state of valve. A case of 0 kgf/cm² in the outlet side results in the highest operating pressure.

2. Min. operating pressure differential

This pressure difference is the lowest pressure difference (a difference between the pressures in the inlet side and the outlet side) required to hold the main valve fully open.

3. Max. system pressure

This pressure is the limit of pressure that can be applied to pipe line. (Line pressure)
[The pressure difference in a solenoid valve must be maintained less than the highest operating pressure difference.]

4. Proof pressure

This is the pressure that can be withstood without deterioration of the performance when valve returns within the range of the operating pressure. (A value under a specified condition.)

Electricity

1. Apparent power (VA)

Volt-ampere is the product of voltage (V) and current (A). Power dissipation (W): For AC, $W = V/A \cos\theta$. For DC, $W = V/A$ (Note) $\cos\theta$ shows power factor.

2. Surge voltage

The surge voltage is a high voltage generated momentarily when cutting the power supply.

3. Hum sound

The hum sound is a noise generated through repeated adsorption and releasing on an armature adsorption surface.

For an AC solenoid, no shading coil releases the spring reaction because of the existence of a 0 point (twice per frequency) of the suction force.

Others

1. Material

NBR: Nitrile rubber

FKM: Fluoro rubber—Trade names: Vitron®, Dai-el®, etc.

EPDM: Ethylene propylene rubber

PTFE: Polytetrafluoroethylene resin—Trade names: Teflon®, Polyflon®, etc.

Polyacetal (POM)—Trade names: Duracon®, Derlin®, etc.

2. Oil preserve treatment

After assembly, valve is put through a parts washer to remove any oil used during assembly.

3. Symbol

The JIS symbol is (☞☞☞☞): this designates the valve to be normally closed.

However, in situations where the secondary pressure exceeds the primary side pressure, the resulting back pressure will cause back flow through the valve.

VC□

VDW

VQ

VX2

VX□

VX3

VXA

VN□

LVC

LVA

LVH

LVD

LVQ

LQ

LVN

TI/
TIL

PA

PAX

PB

Caution

Refer to page 17-6-3 for Safety Instructions and Solenoid Valve Precautions.

Solenoid Coil Assembly

How to Order

VX021 — 001 C B — 01

VX solenoid coil assembly

Application

Size part no.	Applicable series	
001	No.1 Solenoid	Series VX□21
002	No.2 Solenoid	Series VX□22
003	No.3 Solenoid	Series VX□23

Electrical entry

G	Grommet
C	Conduit
D	DIN terminal

Electrical option

Nil	None
S	With surge voltage suppressor
L	With indicator light
Z	With light/ surge voltage suppressor

Terminal box

Nil	None
T	With terminal box

Coil insulation type

B	Class B insulation
H*	Class H insulation

* DIN terminal or DC not available.

Rated voltage ⁽¹⁾

01	100 VAC 50/60 Hz
02	200 VAC 50/60 Hz
03	110 VAC 50/60 Hz
04	220 VAC 50/60 Hz
05	24 VDC
06	12 VDC
07	240 VAC 50/60 Hz
08	48 VAC 50/60 Hz
13	24 VAC 50/60 Hz
23	440 VAC 50/60 Hz
51	6 VDC
53	48 VDC
55	100 VDC
56	110 VDC

Note 1) The voltage codes of 01 to 08 when the suffix "0" is removed, are the same as the solenoid valve model codes.

Ordering example

- Ex.) Series VX21, 100 VAC, Class B insulation, Grommet
 Part no.: "VX021-001GB-01"
- Ex.) Series VX22, 220 VAC, Class B insulation, DIN terminal with terminal box
 Part no.: "VX021-002DBT-04"
- Ex.) Series VX23, 24 VDC, Conduit terminal, with light/surge voltage suppressor
 Part no.: "VX021-003BTZ-05"

Coil Combination

("Electrical Entry"- "Coil Insulation"- "Electrical Option")

Electrical entry	Without electrical option	With electrical option		
		With surge voltage suppressor	With indicator light	With light/ surge voltage suppressor
Grommet	GB	GBS	—	—
	GH	—	—	—
Conduit	CB	—	—	—
	CH	—	—	—
	CBT	CBTS	CBTL	CBTZ
	CHT	CHTS	CHTL	CHTZ
DIN terminal	DB	—	—	—
	DBT	DBTS	DBTL	DBTZ

- * Applicable voltages with light/surge voltage suppressor are as follows;
 100 VAC, 200 VAC, 110 VAC, 220 VAC and 24 VDC.
- * Applicable voltages for "CHTL" and "CHTZ" are as follows; 100 VAC,
 200 VAC, 110 VAC, 220 VAC.

Made to Order Specifications

Splashproof Specifications (Based on JIS C 0920 Based on IEC529IP-X4)

Suffix "-X36" to the end of solenoid coil part number.



Water Hammer Relief, Pilot Operated 2 Port Solenoid Valve For Water and Oil

Series VXR21/22/23



- Water hammer is alleviated.
- Easy to disassemble and reassemble in a short time.

VC□

VDW

VQ

VX2

VX□

VX3

VXA

VN□

LVC

LVA

LVH

LVD

LVQ

LQ

LVN

TI/
TIL

PA

PAX

PB

Variations

Valve

Normally closed (N.C.)

Normally open (N.O.)

Rated voltage

AC
Standard — 100 V, 200 V
Option — 48 V, 110 V, 220 V, 240 V

DC
Standard — 24 V
Option — 12 V

Material

Body — BC6
Seal — NBR, FKM

Electrical entry

- Grommet
- Conduit
- DIN terminal
- Conduit terminal

Model		
Model	Port size Rc	Orifice size (mmØ)
VXR215 $\frac{1}{2}$	1/2, 3/4	20
VXR226 $\frac{3}{4}$	1	25
VXR227 $\frac{1}{2}$	1 1/4	35
VXR238 $\frac{3}{4}$	1 1/2	40
VXR239 $\frac{1}{2}$	2	50

Normally Closed (N.C.)

JIS Symbol

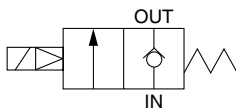

Fluid

Standard specifications	Option ^{Note 1)}
Water (Standard, up to 60°C)	High temperature water (D)
Turbine oil	High temperature oil (D)



Note) Refer to page 17-3-11 "Applicable Fluids Check List" for details of special fluids outside of the standard options and specifications.

Model/Valve Specifications

Connection Thread	Orifice size (mmø)	Model	Min. operating pressure differential (MPa)	Max. operating pressure differential (MPa)		Flow characteristics		Max. system pressure (MPa)	Weight (g)
				Water	Oil	Water, Oil			
1/2	20	VXR2150-04	0.04	1.0	0.7	Water, Oil		1.5	1250
						Av x 10 ⁻⁶ (m ²)	Cv converted		
						160	6.5		
						180	7.5		
						290	12		
						530	22		
1 1/4	35	VXR2270-12	0.04	1.0	0.7	720	30	1.5	3700
1 1/2	40	VXR2380-14				1200	48		4600
2	50	VXR2390-20							



Note) Weight of grommet type. Add 10 g for conduit type, 30 g for DIN terminal 60 g for conduit terminal type respectively.

- Refer to "Glossary" on page 17-3-15 for details of max. operating pressure differential min. operating pressure differential and max. system pressure.

Solenoid Specifications

Model	Power source	Frequency (Hz)	Apparent power (VA)		Power consumption W (Holding)	Temperature rise (°C) (Rated voltage)
			Inrush	Holding		
VXR21	AC	50	20	11	4.5	45
		60	17	7	3.2	35
VXR22	AC	50	40	18	7.5	60
		60	35	12	6	50
VXR23	AC	50	50	21	11	65
		60	45	17	9.5	60
VXR21	DC	—	—	—	6	55
		—	—	—	8	60
VXR22	DC	—	—	—	8	60
		—	—	—	11.5	65



- Note) • They are values in an ambient temperature of 20°C ±5°C and application of rated voltage.
- Changing a coil from AC to DC is possible, but it's impossible to change from DC to AC.
(Hum sound may generate because of no shading coil for DC.)
 - Return voltage is 20% or more of the rated value at AC power and 2% or more at the DC power.
 - Allowable voltage fluctuation is ±10% of the rated voltage.

Operating Fluid and Ambient Temperature

Temperature conditions	Power source	Operating fluid temperature (°C)				Ambient temperature (°C)
		Water (Standard)	Oil (Standard)	High temperature water ⁽²⁾ (D)	High temperature oil ⁽²⁾ (D)	
Maximum	AC	60	60	80	80	60
	DC	40	40	—	—	40
Minimum	AC/DC	1	-5 ⁽¹⁾	—	—	-10



Note 1) 50 cSt or less

Note 2) "D" in parentheses is an option symbol.

The VX* series will be revised shortly.

How to Order (Normally Closed)

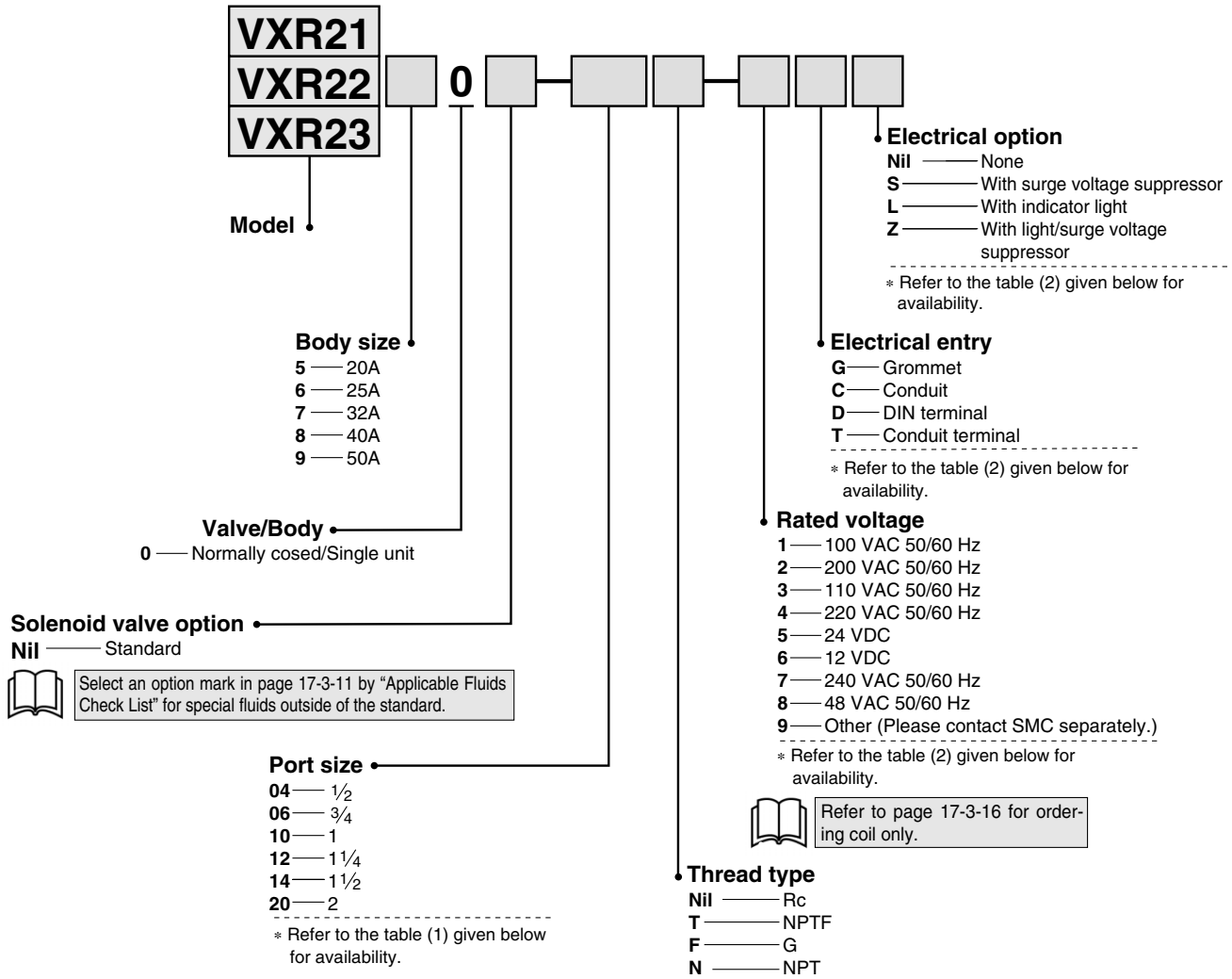

- VC
- VDW
- VQ
- VX2
- VX
- VX3
- VXA
- VN
- LVC
- LVA
- LVH
- LVD
- LVQ
- LQ
- LVN
- TI/TIL
- PA
- PAX
- PB

Table(1)
Connection Size and Applicable Model

Size	Applicable model
1/2	VXR2150-04
3/4	VXR2150-06
1	VXR2260-10
1 1/4	VXR2270-12
1 1/2	VXR2380-14
2	VXR2390-20

Ordering example

(Example) Series VXR21, Rc 3/4, 24 VDC,
Conduit terminal
(Part no.) **VXR2150-06-5T**

Table(2)
Rated Voltage-Electrical Entry-Electrical

Insulation type	Class B				Class H		
	G	C	D, T	G, C	T		
Electrical entry	G	C	D, T	G, C	T		
Electrical option	S ^{Note)}	—	S, L, Z	—	S, L, Z		
AC	1 (100 V)	●	●	●	●	●	
	2 (200 V)	●	●	●	●	●	
	3 (110 V)	●	●	●	●	●	
	4 (220 V)	●	●	●	●	●	
	7 (240 V)	●	●	●	—	●	—
DC	8 (48 V)	●	●	●	—	●	
	5 (24 V)	●	●	●	—	—	
	6 (12 V)	●	●	●	—	—	

Note) Surge voltage suppressor is attached in the middle of lead wire.

Made to Order Specifications

Splashproof Specifications (Based on JIS C 0920 / Based on IEC529IP-X4)

VXR Model — Port size — Electrical entry - X36
DIN terminal or class H coil not available.

Normally Open (N.O.)

JIS Symbol

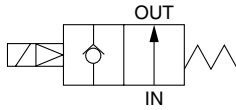

Fluid

Standard specifications	Option ^{Note)}
Water (Standard, up to 60°C)	High temperature water (D)
Turbine oil	High temperature oil (D)



Note) Refer to page 17-3-11 "Applicable Fluids Check List" for details of special fluids outside of the standard options and specifications.

Model/Valve Specifications

Connection Thread	Orifice size (mmø)	Model	Min. operating pressure differential (MPa)	Max. operating pressure differential (MPa)		Flow characteristics		Max. system pressure (MPa)	Weight (g)
				Water	Oil	Water, Oil Av x 10 ⁻⁶ m ²	Cv converted		
1/2	20	VXR2152-04	120	0.7	0.6	160	6.5	1.5	1270
3/4	20	VXR2152-06	135			180	7.5		1270
1	25	VXR2262-10	210			290	12		1770
1 1/4	35	VXR2272-12	400			530	22		2900
1 1/2	40	VXR2382-14	540			720	30		3700
2	50	VXR2392-20	860			1200	48		4600



Note) Weight of grommet type. Add 10 g for conduit type, 30 g for DIN terminal type, 60 g for conduit terminal type respectively.

- Refer to "Glossary" on page 17-3-15 for details of max. operating pressure differential and min. operating pressure differential and max. system pressure.

Solenoid Specifications

Model	Power source	Frequency (Hz)	Apparent power (VA)		Power consumption (W) (Holding)	Temperature rise (°C) (Rated voltage)
			Inrush	Holding		
VXR21	AC	50	25	12	5	50
		60	20	8	3.5	35
VXR22	AC	50	45	20	8	55
		60	40	15	6.5	45
VXR23	AC	50	60	25	0.5	60
		60	50	20	9.5	50
	DC	—	—	—	11.5	55



- Note)
- They are values in an ambient temperature of 20°C ± 5°C and application of rated voltage.
 - Changing coils from AC to DC and vice versa is impossible. because of different core shapes.
 - Return voltage is 20% or more of the rated value at AC power and 5% or more at the DC power.
 - Allowable voltage fluctuation is ±10% of the rated voltage.

Operating Fluid and Ambient Temperature

Temperature conditions	Power source	Operating fluid temperature (°C)				Ambient temperature (°C)
		Water (Standard)	Oil (Standard)	High temperature water ⁽²⁾ (D)	High temperature oil ⁽²⁾ (D)	
Maximum	AC	60	60	80	80	60
	DC	40	40	—	—	40
Minimum	AC/DC	1	-5 ⁽¹⁾	—	—	-10



Note 1) 50 cSt or less

Note 2) "D" in parentheses is an option symbol.

The VX* series will be revised shortly.

How to Order (Normally Open)

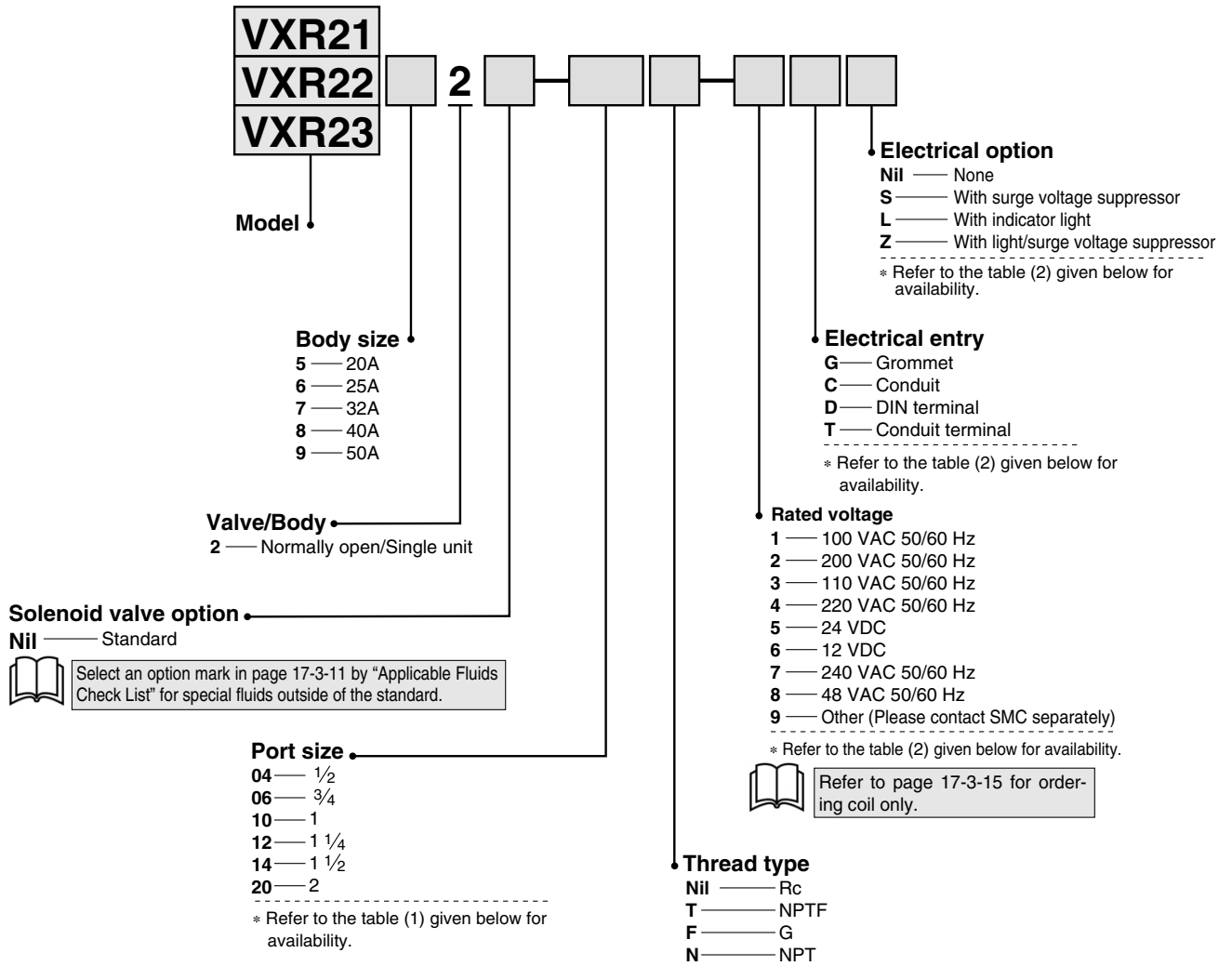

Table (1)
Connection Size and Applicable Model

Size	Applicable model
1/2	VXR2152-04
3/4	VXR2152-06
1	VXR2262-10
1 1/4	VXR2272-12
1 1/2	VXR2382-14
2	VXR2392-20

Ordering example

(Example) Series VXR22, Rc 1 1/4, 200 VAC,
Conduit terminal
(Part no.) **VXR2272-12-2G**

Table (2)
Rated Voltage-Electrical Entry-Electrical Option

Insulation type	Class B				Class H		
	G	C	D, T	L, Z	G, C	S	T
Electrical entry	S	—	S	L, Z	—	S	L, Z
Electrical option	S	—	S	L, Z	—	S	L, Z
AC	1 (100 V)	●	●	●	●	●	●
	2 (200 V)	●	●	●	●	●	●
	3 (110 V)	●	●	●	●	●	●
	4 (220 V)	●	●	●	●	●	●
	7 (240 V)	●	●	●	—	●	●
DC	8 (48 V)	●	●	●	—	●	—
	5 (24 V)	●	●	●	—	—	—
	6 (12 V)	●	●	●	—	—	—



Note) Surge voltage suppressor is attached in the middle of lead wire.

Made to Order Specifications

Splashproof Specifications (Based on JIS C 0920
Based on IEC529IP-X4)

VXR Model — Port size — Electrical entry - X36
DIN terminal or class H coil not available.

Construction/Principal Parts Material

Normally Closed (N.C.)

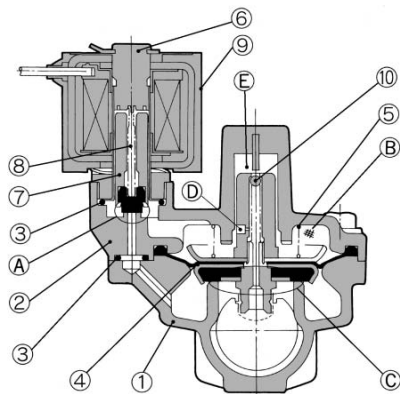

Operation

< Valve opened > When the coil ⑨ is energized the armature assembly ⑦ is attracted into the core of the core assembly ⑥ and the pilot valve ① opens. Then the pressure in the pressure action chamber ② falls to open the main valve ③.

< Valve closed > When the coil ⑨ is not energized, the pilot valve ① is closed and the pressure in the pressure action chamber B rises and the main valve ③ closes.

Water hammer relieving

Check valve mechanism is provided in the ⑤ side of the supply orifice ④ and ⑤ and supply into the pressure action chamber ② can be controlled with two stages by moving the diaphragm assembly ④. After release of the energy, when the open amount of the main valve ③ becomes small, ⑤ is blocked. A low valve closing speed relieves the water hammer.

No.	Description	Material	
		Standard	Option
①	Body	BC6	—
②	Bonnet	BC6	—
③	O-ring	NBR	FKM
④	Diaphragm assembly	Stainless steel, Brass NBR	Stainless steel, Brass FKM
⑤	Valve spring	Stainless steel	—
⑥	Core assembly	Stainless steel, Copper	—
⑦	Armature assembly	Stainless steel, NBR	Stainless steel, FKM
⑧	Return spring	Stainless steel	—
⑨	Coil assembly	Class B molded	Class H molded

Normally Open (N.O.)

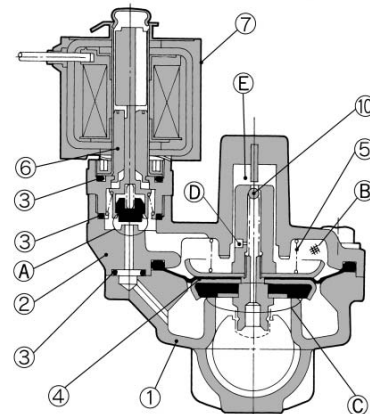

Operation

< Valve opened > When the coil ⑦ is energized the opened pilot ① closes, the pressure in the pressure action chamber ② rises and the main valve ③ closes.

< Valve closed > When the coil ⑦ is not energized, the closed pilot valve ① opens, the pressure in the pressure action chamber B drops and the main valve ③ opens.

Water hammer relieving

Check valve mechanism is provided in the ⑤ side of the supply orifice ④ and ⑤ and supply into the pressure action chamber ② can be controlled with two stages by moving the diaphragm assembly ④. After release of the energizing, when the open amount of the main valve ③ becomes small, ⑤ is blocked. A low valve closing speed relieves the water hammer.

No.	Description	Material	
		Standard	Option
①	Body	BC6	—
②	Bonnet	BC6	—
③	O-ring	NBR	FKM
④	Diaphragm assembly	Stainless steel, Brass NBR	Stainless steel, Brass FKM
⑤	Valve spring	Stainless steel	—
⑥	Core assembly	Stainless steel, Copper, NBR, Polyacetal, PTFE	Stainless steel, Copper FKM, PTFE
⑦	Coil assembly	Class B molded	Class H molded

Water Hammer Relief, Pilot Operated 2 Port Solenoid Valve For Water and Oil Series VXR21/22/23

The VX* series will be revised shortly.

Water Hammer Relieving Characteristics (VXR2150/2152/2260/2262)

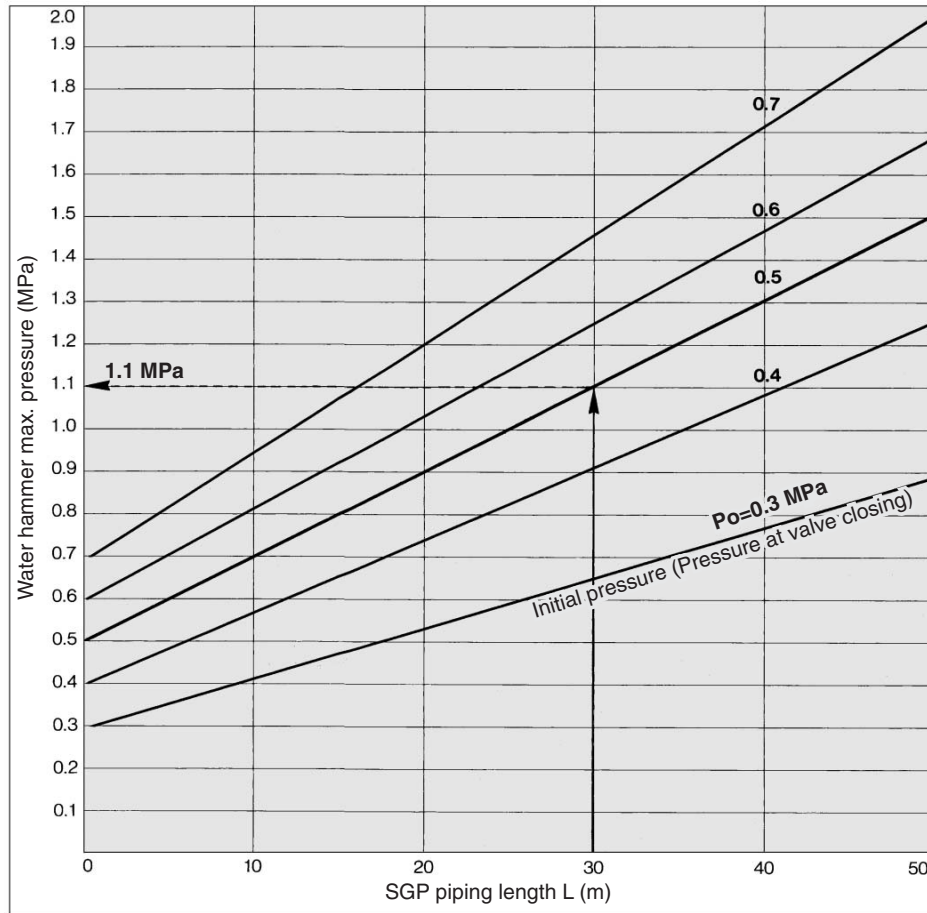

Water hammer

(Example) Series VXR2 prevents damage of piping, equipment and system and generation of vibration through a great relieving of a water hammer generated using an ordinary solenoid valve.

How to read the graph

When the SGP piping having the same bore as the solenoid valve is 30 m in length, the maximum pressure at the initial pressure of 0.5 MPa results in about 1.1 MPa. (General purpose solenoid valve is 4.0 to 7.0 MPa.)

Water Hammer Relieving Characteristics (VXR2270/2272/2380/2382/2390/2392)

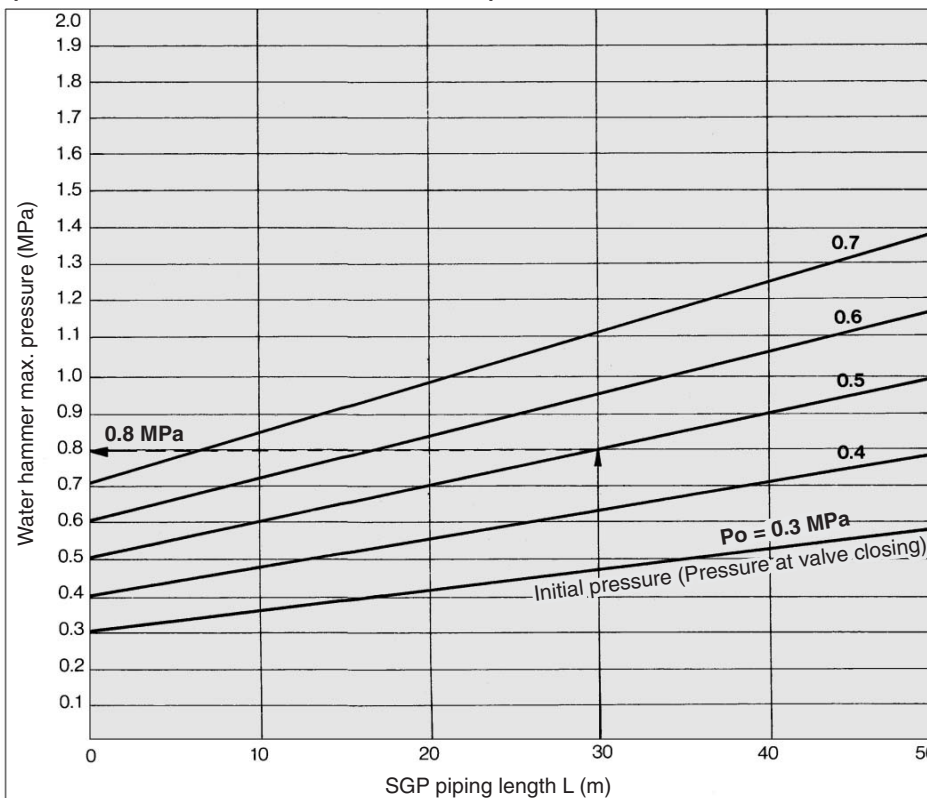

How to read the graph

When the SGP piping having the same bore as the solenoid valve is 30 m. in the length, the maximum pressure at the initial pressure of 0.5 MPa results in about 0.8 MPa. (General purpose solenoid valve is 2.0 to 4.0 MPa.)

VC

VDW

VQ

VX2

VX

VX3

VXA

VN

LVC

LVA

LVH

LVD

LVQ

LQ

LVN

TI/
TIL

PA

PAX

PB

Dimensions

Normally Closed: VXR21□0/22□0/23□0 Normally Open: VXR21□2/22□2/23□2

Grommet: G

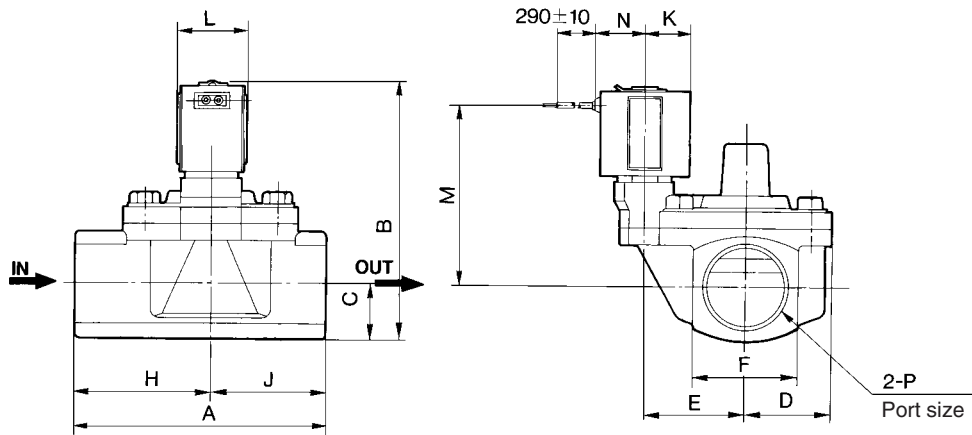

Conduit: C

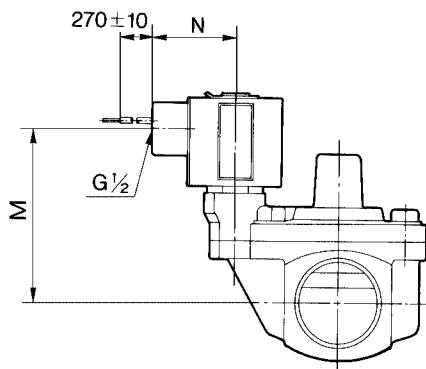

DIN terminal: D

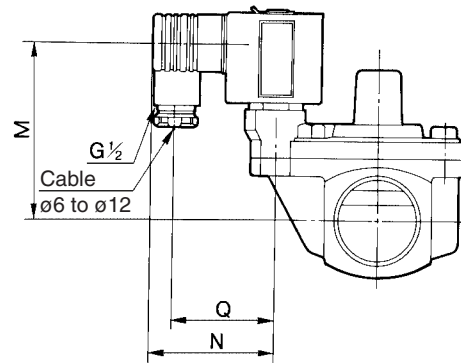

Conduit terminal: T

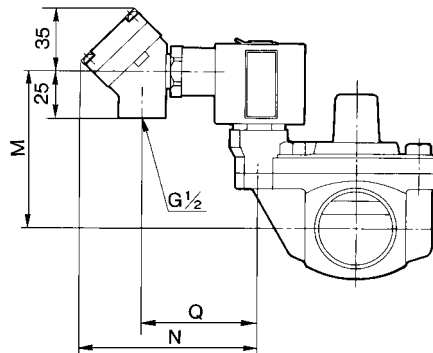

Model		Port size P Rc	A	B	C	D	E	F	H	J	K	L	Electrical entry									
													Grommet		Conduit		DIN terminal			Conduit terminal		
Normally closed	Normally open												M	N	M	N	M	N	Q	M	N	Q
VXR2150-06	VXR2152-06	1/2, 3/4	80	101 (112)	18	32.5	36	36	39	41	20	30	74 (81)	23	67 (74)	39	67 (74)	59	47	67 (74)	92	59
VXR2260-10	VXR2262-10	1	90	119 (136)	21	36.5	40	42	45	45	23	35	88 (98)	25.5	80 (90)	41.5	80 (90)	60	48	80 (90)	95	62
VXR2270-12	VXR2272-12	1 1/4	125	126 (143)	26.5	43.5	51.5	53	67.5	57.5	23	35	90 (100)	25.5	82 (92)	41.5	82 (92)	60	48	82 (92)	95	62
VXR2380-14	VXR2382-14	1 1/2	132	142 (157)	30	46.5	54.5	60	72	60	25.5	40	101 (111)	28	93 (103)	44.5	93 (103)	62	50	93 (103)	97	64
VXR2390-20	VXR2392-20	2	150	153 (168)	35.5	52	59	70	81	69	25.5	40	106 (116)	28	98 (108)	44.5	98 (108)	62	50	98 (108)	97	64

(): N.O.