



Exhaust Cleaner for Clean Rooms  
**AMP Series**



Exhaust Air Cleanliness Equivalent to Class 100  
Piping Labor Reduced  
Increased Space Savings  
Worry Free Two Stage Element Construction

# Series AMP

## Exhaust Cleaner for Clean Rooms

### An exhaust cleaner that can be used inside a clean room

### Exhaust air cleanliness: Equivalent to Class 100

(Consult SMC in advance, as this will differ depending on the operating conditions.)

**Particle density for particle of 0.3 $\mu$ m or larger is less than 3.5 particles/l**

Since it is possible to release exhaust air from pneumatic equipment directly into a clean room, piping to exhaust ducts is unnecessary.

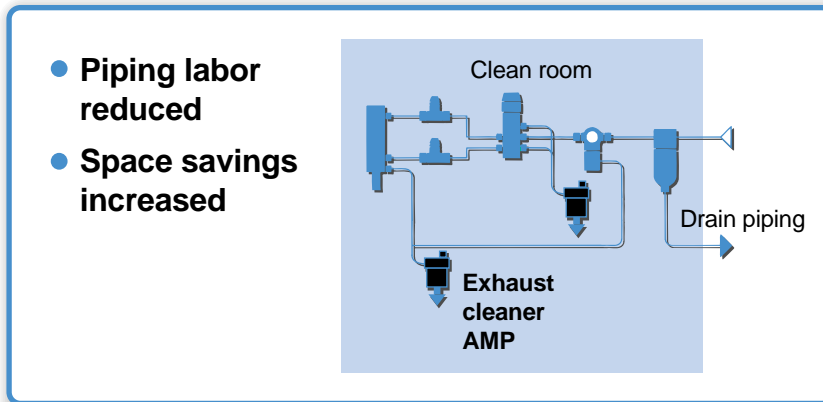

### Worry free two stage element construction

After the first element is saturated with oil, the oil flowing into the secondary side is collected by the second element. This prevents discharge to the outside for a fixed time.

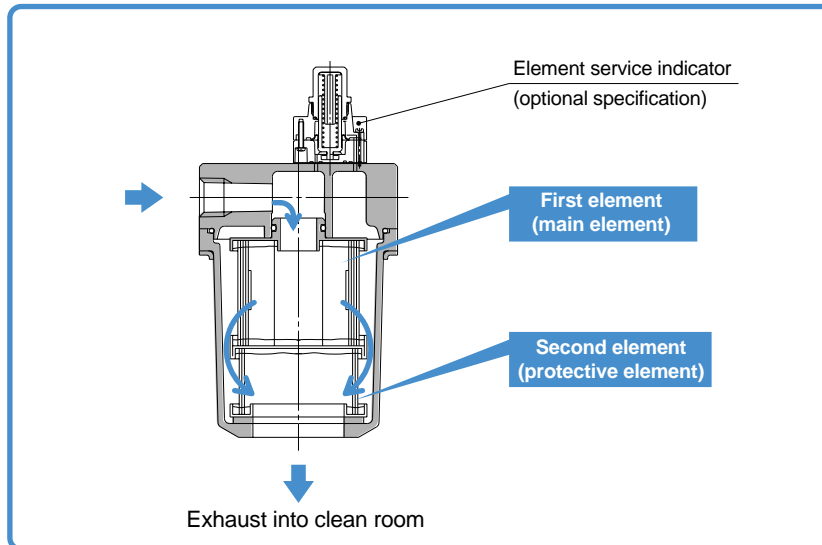

### With indicator function

The element life (standard) can be visually confirmed.

#### Element service indicator

Element clogging is detected by a pressure differential, and indicated by a red symbol. (optional specification)

#### First element

Oil saturation of the element is indicated by red dots.

### Series variations

Model	Thread type	Port size				Optional
		1/4	3/8	1/2	3/4	
AMP220	Rc	•	•			• Flow direction Right → Down • With element service indicator
AMP320	NPT		•	•		
AMP420	G			•	•	

### Silencing effect: 40dB (A) or more

### Double packaging

Shipped in double packaging using antistatic bags.

How to Order

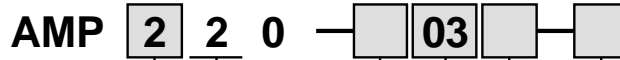

**Body size**

2	1/4 standard
3	3/8 standard
4	1/2 standard

**Element construction**

2	2 stage
---	---------

**Thread type**

Nil	Rc
N	NPT
F	G

**Optional specifications**

Nil	None
R	Flow direction Right→Down
T	With element service indicator

**Accessories (optional)**

Nil	None
B	With bracket

Note) The bracket is not attached.

**Port size**

Symbol	Port size	Body size		
		2	3	4
02	1/4	●	—	—
03	3/8	●	●	—
04	1/2	—	●	●
06	3/4	—	—	●

Models

Model	AMP220	AMP320	AMP420
Max. flow capacity $l/min$ (ANR)(SCFM)	200 (7)	500 (17.5)	1000 (35)
Port size (nominal size B)	1/4, 3/8	3/8, 1/2	1/2, 3/4
Weight kg (lb)	0.43 (0.95)	0.68 (1.50)	1.15 (2.54)

Specifications

Fluid	Compressed air
Element upstream pressure	0.1MPa or less (14.5 psi or less)
Ambient and fluid temperature	5 to 50°C (41° to 122°F)
Filtration degree	0.01 $\mu$ m (95% filtered particle size)
Downstream cleanliness	Particle density for particles 0.3 $\mu$ m or larger $\leq$ 3.5 particles/ $l$ (ANR) (100 particles/ $ft^3$ or less)
Element life	One year from first use (or when upstream pressure reaches 0.1MPa (14.5 psi), even if less than one year from first use)
Element life indication (saturated with oil)	Element color indication (replace if red dots appear on the element surface, even if less than one year from first use)
Element construction	Two stage element
Silencing effect	40dB (A) or more

Accessories (Optional)

Applicable model	AMP220	AMP320	AMP420
Bracket assembly (with cap bolt with spring washers)	BM66	BM67	BM68

## Construction

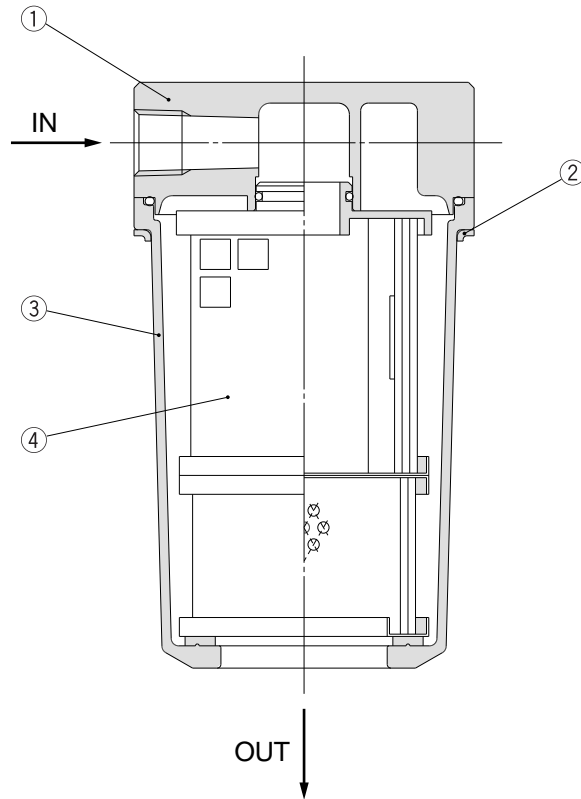

### Parts list

No.	Description	Material	Note
1	<b>Body</b>	Aluminum alloy	Chromated, Baking finish
2	<b>Ring</b>	Carbon steel	Electroless nickel plated
3	<b>Case</b>	Resin	

### Replacement parts

No.	Description	Part number			Note
		<b>AMP220</b>	<b>AMP320</b>	<b>AMP420</b>	
4	Element assembly	AMP-EL220	AMP-EL320	AMP-EL420	With O-ring

Note) The first and second elements are integrated, and cannot be replaced separately.

## Dimensions (mm)

1 in = 25.4mm

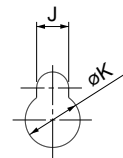
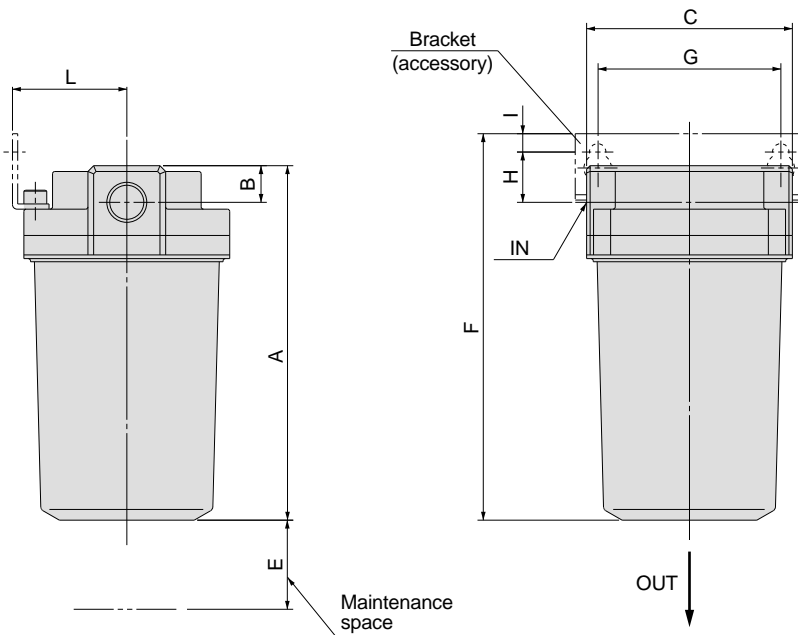
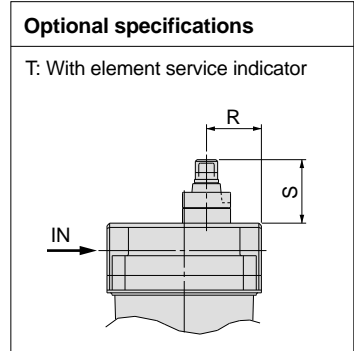
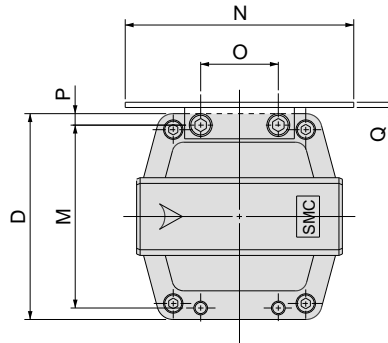

### Bracket mounting hole

Model	Applicable screw
AMP220	M5 hexagon socket head cap screw
AMP320	M6 hexagon socket head cap screw
AMP420	M8 hexagon socket head cap screw

(mm)

Model	Port size (nominal size B)	A	B	C	D	E	Bracket related dimensions												Element service indicator related dimensions	
							F	G	H	I	J	K	L	M	N	O	P	Q	R	S
AMP220	1/4, 3/8	108	13	76	76	80	123	66	20	8	6	10	40	66	84	28	5	2	26	37
AMP320	3/8, 1/2	155	16	90	90	120	169	80	22	8	7	12	50	80	100	34	5	2.3	32	37
AMP420	1/2, 3/4	221	19	106	106	180	237	90	25	10	10	15	55	88	110	50	9	3.2	37	37

1 in = 25.4mm

**Selection**

**⚠ Caution**

1. When selecting an exhaust cleaner, refer to the selection method shown below, as the selection method will differ for exhaust from actuator drive systems, etc., and exhaust from ejectors, etc.

(Take note that an exhaust flow rate exceeding that of the model selected can cause a drop in exhaust air cleanliness, reduced performance of drive equipment and ejectors, etc., and damage to the element.)

**2. Exhaust from drive systems**

1. Find the air flow required for the actuator to be used. When operating with common piping, add up the required air flow for all actuators that will be operated simultaneously and find the maximum air flow.
2. Select a model such that the maximum required air flow obtained in (1) does not exceed the maximum flow rate line of the exhaust cleaner.

**3. Exhaust from ejectors, etc.**

1. In case of ejectors or other equipment whose performance can be affected by back pressure on the exhaust air, confirm the range in which the equipment will not be affected by back pressure.
2. In the case of ejectors, the exhaust flow rate is the total of the maximum suction flow rate and the air consumption. Since the method of calculating the exhaust flow rate differs in this way depending on the equipment, confirm this in the catalog or instruction manual of the equipment to be used.
3. When operating with common piping, add up the exhaust flow rates for all equipment that will be exhausted simultaneously and find the maximum exhaust flow rate.
4. Find the upstream pressure in the flow characteristic graph, using the maximum exhaust flow rate obtained in (3) as the exhaust flow rate. Select a model such that the upstream pressure is lower than the back pressure generated when the exhaust flow rate is at a maximum.

Flow characteristic graph

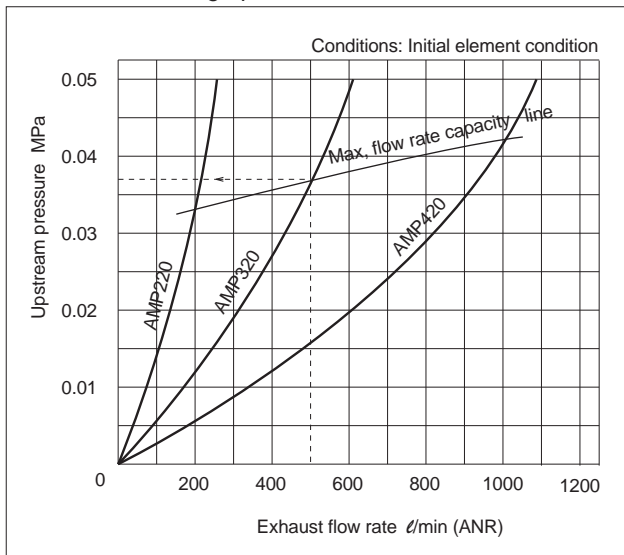

Viewing the graph: When using AMP320 at a flow rate of 500l/min, the upstream pressure is 0.037MPa.

**⚠ Caution**

4. Exhaust flow speed characteristics are shown in graph 2.

1. Operate giving consideration to the effects of turbulence on dust, etc., that has settled on the floor or other areas.
2. In cases where there is concern about the effect of turbulence on dust, install in a location where dust will not be affected.

Exhaust flow speed

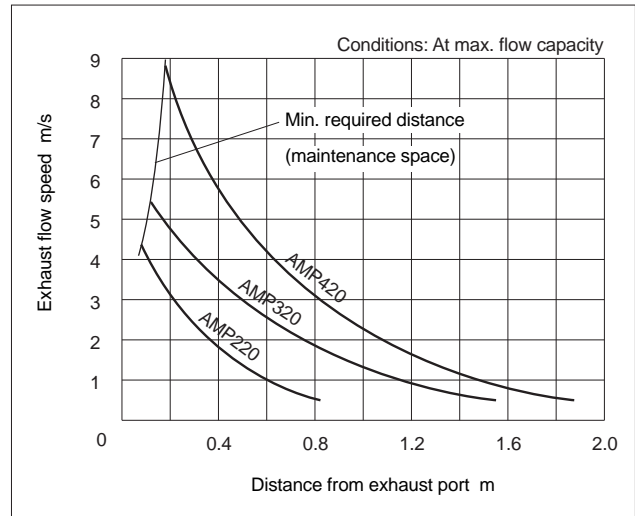

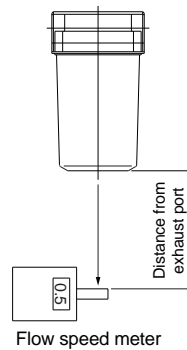

<Measurement>



1MPa = 145 psi  
 1 l/min = 0.035 SCFM  
 1m = 3.28 ft.

These safety instructions are intended to prevent a hazardous situation and/or equipment damage. These instructions indicate the level of potential hazard by a label of "**Caution**", "**Warning**" or "**Danger**". To ensure safety, be sure to observe ISO 4414 Note 1), JIS B 8370 Note 2) and other safety practices.

 **Caution** : Operator error could result in injury or equipment damage.

 **Warning** : Operator error could result in serious injury or loss of life.

 **Danger** : In extreme conditions, there is a possible result of serious injury or loss of life.

Note 1) ISO 4414: Pneumatic fluid power – Recommendations for the application of equipment to transmission and control systems

Note 2) JIS B 8370: General Rules for Pneumatic Equipment

 **Warning**

- 1. The compatibility of pneumatic equipment is the responsibility of the person who designs the pneumatic system or decides its specifications.**  
 Since the products specified here are used in various operating conditions, their compatibility for the specific pneumatic system must be based on specifications or after analysis and/or tests to meet your specific requirements.
- 2. Only trained personnel should operate pneumatically operated machinery and equipment.**  
 Compressed air can be dangerous if an operator is unfamiliar with it. Assembly, handling or repair of pneumatic systems should be performed by trained and experienced operators.
- 3. Do not service machinery/equipment or attempt to remove components until safety is confirmed.**
  1. Inspection and maintenance of machinery/equipment should only be performed after confirmation of safe locked-out control positions.
  2. When equipment is to be removed, first confirm the safety process as mentioned above.
  3. Before machinery/equipment is restarted, confirm that safety measures are implemented, and proceed with caution.
- 4. Contact SMC if the product is to be used in any of the following conditions:**
  1. Conditions and environments beyond the given specifications, or if product is used outdoors.
  2. Installation on equipment in conjunction with atomic energy, railway, air navigation, vehicles, medical equipment, food and beverages, recreation equipment, emergency stop circuits, press applications, or safety equipment.
  3. An application which has the possibility of having negative effects on people, property, or animals, requiring special safety analysis.

## Precautions on Design

Employ a safe design so that the following type of unexpected conditions will not occur.

### Warning

1. **Implement safety measures in the system to deal with accidents which may occur if upstream pressure rises because of element clogging or air supply trouble, etc.**

## Selection

### Warning

1. **Confirm the specifications.**

The products contained in this catalog are designed only for use in compressed air systems (including vacuum).

Do not operate outside the specified range of pressure and temperature, etc., as this will cause damage or malfunction. (Refer to specifications.)

Consult SMC before using any fluid other than compressed air.

2. **When selecting equipment, first adequately confirm the purpose for which it will be used, the required specifications and the operating conditions (pressure, flow rate, temperature, environment), etc. Then select from the latest catalog so that the specification range will not be exceeded. Contact SMC in advance with questions about any unclear points.**

3. **This product cannot be used on board vehicles or vessels.**

This product cannot be used on board vehicles, vessels or other transportation devices, because vibration will cause damage. If this type of use is unavoidable, contact SMC in advance.

### Caution

1. **Do not allow flow greater than the rated flow rate.**

If the flow exceeds the rated flow rate even momentarily, this can cause drainage and oil to be sprayed into the downstream side, and damage to equipment.

## Mounting

### Warning

1. **Instruction manual**

The product should be mounted and operated after reading the manual carefully and having a good understanding of its contents. The manual should also be kept where it can be referred to whenever necessary.

2. **Ensure sufficient maintenance space.**

Be sure to allow the space required for maintenance and inspections.

3. **Be certain to tighten threads with the proper torque.**

1. When screwing in piping, hold the side with the female thread and tighten with the recommended proper torque.

If the tightening torque is insufficient, this will cause looseness and faulty sealing. If the tightening torque is too high, this will cause damage to the threads, etc. Furthermore, if the female thread side is not held when tightening, a large force will be applied directly to the piping bracket and other parts, which may cause damage.

#### Recommended proper torque N·m

Connection threads	M5	1/8	1/4	3/8	1/2	3/4	1
Torque	1.5 to 2	7 to 9	12 to 14	22 to 24	28 to 30	28 to 30	36 to 38

2. Twisting moment or bending moment other than the dead weight of the equipment should not be applied.

To avoid damage, external piping should be supported separately from the product.

3. Non-flexible piping is easily subject to the propagation of excessive moment load and vibration, etc., from steel and other similar pipes. Therefore, some type of flexible tubing should be used between the equipment and the external piping to prevent this effect.

### Caution

1. **Confirm the mounting position.**

Since the mounting position is different for each piece of equipment, this point should be confirmed either in this catalog or in the instruction manual.

2. **Ensure sufficient maintenance space.**

When installing and mounting, be sure to allow the space required for maintenance and inspections. Confirm the necessary maintenance space in the instruction manual for each piece of equipment.



### Piping

#### Caution

##### 1. Preparation before piping

Before piping is connected, it should be thoroughly blown out with air (flushing) or washed to remove chips, cutting oil and other debris from inside the pipe.

##### 2. Wrapping of pipe tape

When screwing together pipes and fittings, etc., be certain that chips from the pipe threads and sealing material do not get inside the piping.

Further, when pipe tape is used, leave 1.5 to 2 thread ridges exposed at the end of the threads.

##### 3. Implement measures to prevent drainage from collecting inside piping.

For example, drains should be installed in the lower sections of piping that rises, or piping should be designed with a slight taper provided along the direction of flow so that drainage will not accumulate.

### Air Supply

#### Warning

##### 1. Types of fluid

This product is designed for use with compressed air. Contact SMC in case a different fluid is to be used.

Contact SMC regarding the types of fluids which can be used in products designed for use with general purpose fluids.

##### 2. Do not use compressed air which contains chemicals, organic solvents or corrosive gases.

Do not use compressed air containing chemicals, organic solvents, salt or corrosive gases, as this can cause damage and reduced performance, etc.

##### 3. Operating pressure range

The operating pressure range is determined by the equipment being used. Operation beyond this range can cause damage and reduced performance, etc.

### Operating Environment

#### Warning

##### 1. Do not use in the following environments, as this can cause damage and reduced performance.

- Locations with an atmosphere of corrosive gases, organic solvents or chemical solutions, and locations where there may be contact with the same.
- Locations where there is contact with sea spray, water or steam.
- Locations which receive direct sunlight. (Sunlight should be blocked to prevent deterioration of resin from ultra violet rays and over heating, etc.)
- Locations near heat sources with poor ventilation. (Heat sources should be blocked off, because radiated heat may cause damage due to softening of materials.)

### Operating Environment

#### Warning

- Locations with impacts or vibration. (Confirm specifications.)
- Locations with high moisture and dust. (Contact SMC in advance.)

##### 2. Adhere to the fluid and ambient temperature ranges.

The fluid and ambient temperatures are determined by the equipment being used. Operation beyond this range can cause damage, failure or malfunction, etc.

### Maintenance

#### Warning

##### 1. Maintenance should be performed in accordance with the procedures in the instruction manual.

If handled improperly, this can cause damage or malfunction in equipment and devices, etc.

##### 2. Maintenance operations

Since compressed air can be dangerous if handled improperly, element replacement and other maintenance, etc., should be performed by personnel having sufficient knowledge and experience pertaining to pneumatic equipment, while also adhering to the product specifications.

##### 3. Pre-maintenance checks

When the product is to be demounted, be sure to shut off the supply pressure, release compressed air in the pipelines and confirm an atmospheric release condition before proceeding.

##### 4. Post maintenance checks

After mounting, repair or renovation, supply compressed air and perform suitable function and leak tests. If an audible leak is detected or equipment does not operate properly, stop operation and confirm that mounting is correct.

##### 5. When performing inspections, set the compressed air pressure to zero.

When the compressed air side is to be disassembled for inspections or filter element replacement, etc., first confirm that the pressure is at zero before proceeding.

##### 6. Disassembly and modification is prohibited.

Do not disassemble or modify the main unit.

#### Caution

##### 1. Do not step on or place heavy objects on the unit.

The equipment may be deformed or damaged, and if balance is lost, a fall may cause injury.

### Mounting

#### Caution

1. Air piping should be thoroughly flushed before mounting.
2. When piping and fittings, etc. are being screwed together, take care that chips from the pipe threads, sealing material and other debris do not get inside the piping.  
Further, when pipe tape is used, leave 1.5 to 2 thread ridges exposed at the end of the threads.
3. Mount the unit vertically. Furthermore, when mounting is performed, the case section (resin) will be damaged if it is held while screwing in piping, etc. Screw in piping while holding the upper body area (die-cast aluminum) with a wrench or other tool.
4. In cases such as common piping, reverse flow may occur depending on the timing for switching of solenoid valves, etc. In this situation, install a check valve on the upstream side.
5. Ensure the necessary space for maintenance and inspections. (Confirm with the dimensions on page 3.)

### Operating Environment

#### Warning

1. Do not use in environments or locations where there is a danger of the case or element service indicator (optional specification: T) being penetrated.
2. Since the case material is nylon, avoid use in environments with chemicals such as alcohol, thinner, carbon tetrachloride, chloroform, aniline, cyclohexane, trichloroethylene, sulfuric acid, lactic acid, water soluble cutting oil (alkaline), etc.  
Furthermore, use a neutral detergent for cleaning the case.
3. Do not use in locations where static electric charge will be a problem.
4. Block off heat from nearby heat sources.  
If heat sources are located nearby, the temperature of the product may rise above the operating temperature range due to radiated heat. Block off this heat with a cover, etc.

### Supply Air

#### Caution

1. The product cannot be used with air containing water droplets.
2. Install a mist separator (series AM), micro mist separator (series AMD), or micro mist separator with pre-filter (series AMH) on the air supply side.
3. When using ejectors, etc., do not allow liquids such as water or oil to be drawn in with the air.

### Maintenance

#### Caution

1. Replace the element after one year of use, or when the upstream pressure reaches 0.1MPa even if one year has not elapsed. Note)

If operation is continued without replacing the element, the cleanliness of the exhaust air will decline.

When replacing the element, also install a new O-ring.

(When equipped with an element service indicator (optional specification: T), the condition of the element can be easily confirmed.)

2. When saturated with oil, red dots appear on the surface of the first element. Check it once a day and replace it immediately with a new element when red dots appear.

If operation is continued after red dots have appeared, the second element will also be saturated with oil, and oil mist imbued with red dye will be mixed with the exhaust air, contaminating the surrounding air.

Note) The upstream pressure discussed here indicates the pressure which arises on the upstream side of the element when air of a certain flow rate flows through the exhaust cleaner. The relation between this upstream pressure and the air flow rate can be confirmed in the flow characteristic graph on page 4.

### Operation in a Clean Room

#### Caution

1. Open the inner bag of the double packaging in a clean room or other clean environment.
2. In a down flow area, mount with the exhaust port facing downward.
3. Avoid mounting in locations where exhaust air will blow directly on work pieces, etc.
4. Confirm the exhaust flow speed, and operate giving consideration to the effect of turbulence on dust, etc., in a clean room.

# World Wide SMC Support...

**North American Branch Offices** For a branch office near you call: 1-800-SMC-SMC1 (762-7621)

**SMC Pneumatics Inc. (Atlanta)**  
1440 Lakes Parkway, Suite 600  
Lawrenceville, GA 30043  
Tel: (770) 624-1940  
FAX: (770) 624-1943

**SMC Pneumatics Inc. (Cleveland)**  
2305 East Aurora Rd., Unit A-3  
Twinsburg, OH 44087  
Tel: (330) 963-2727  
FAX: (330) 963-2730

**SMC Pneumatics Inc. (Milwaukee)**  
16850 W. Victor Road  
New Berlin, WI 53151  
Tel: (262) 827-0080  
FAX: (262) 827-0092

**SMC Pneumatics Inc. (Richmond)**  
5377 Glen Alden Drive  
Richmond, VA 23231  
Tel: (804) 222-2762  
FAX: (804) 222-5221

**SMC Pneumatics Inc. (Austin)**  
9101 Wall Street, Suite 1030  
Austin, TX 78754  
Tel: (512) 926-2646  
FAX: (512) 926-7055

**SMC Pneumatics Inc. (Columbus)**  
3687 Corporate Drive  
Columbus, OH 43231  
Tel: (614) 895-9765  
FAX: (614) 895-9780

**SMC Pneumatics Inc. (Mnpls.)**  
990 Lone Oak Road, Suite 162  
Eagan, MN 55121  
Tel: (651) 688-3490  
FAX: (651) 688-9013

**SMC Pneumatics Inc. (Rochester)**  
245 Summit Point Drive  
Henrietta, NY 14467  
Tel: (716) 321-1300  
FAX: (716) 321-1865

**SMC Pneumatics Inc. (Boston)**  
Zero Centennial Drive  
Peabody, MA 01960  
Tel: (978) 326-3600  
Fax: (978) 326-3700

**SMC Pneumatics Inc. (Dallas)**  
12801 N. Stemmons Frwy, Ste. 815  
Dallas, TX 75234  
Tel: (972) 406-0082  
FAX: (972) 406-9904

**SMC Pneumatics Inc. (Nashville)**  
5000 Linbar Drive, Suite 297  
Nashville, TN 37211  
Tel: (615) 331-0020  
FAX: (615) 331-9950

**SMC Pneumatics Inc. (S.F.)**  
85 Nicholson Lane  
San Jose, CA 95134  
Tel: (408) 943-9600  
FAX: (408) 943-9111

**SMC Pneumatics Inc. (Charlotte)**  
5029-B West W.T. Harris Blvd.  
Charlotte, NC 28269  
Tel: (704) 597-9292  
FAX: (704) 596-9561

**SMC Pneumatics Inc. (Detroit)**  
2990 Technology Drive  
Rochester Hills, MI 48309  
Tel: (248) 299-0202  
FAX: (248) 293-3333

**SMC Pneumatics Inc. (Newark)**  
3434 US Hwy. 22 West, Ste. 110  
Somerville, NJ 08876  
Tel: (908) 253-3241  
FAX: (908) 253-3452

**SMC Pneumatics Inc. (St. Louis)**  
4130 Rider Trail North  
Earth City, MO 63045  
Tel: (314) 209-0080  
FAX: (314) 209-0085

**SMC Pneumatics Inc. (Chicago)**  
27725 Diehl Road  
Warrenville, IL 60555  
Tel: (630) 393-0080  
FAX: (630) 393-0084

**SMC Pneumatics Inc. (Houston)**  
9001 Jameel, Suite 180  
Houston, TX 77040  
Tel: (713) 460-0762  
FAX: (713) 460-1510

**SMC Pneumatics Inc. (Phoenix)**  
2001 W. Melinda Lane  
Phoenix, AZ 85027  
Tel: (623) 492-0908  
FAX: (623) 492-9493

**SMC Pneumatics Inc. (Tampa)**  
8507-H Benjamin Road  
Tampa, FL 33634  
Tel: (813) 243-8350  
FAX: (813) 243-8621

**SMC Pneumatics Inc. (Cincinnati)**  
4598 Olympic Blvd.  
Erlanger, KY 41018  
Tel: (606) 647-5600  
FAX: (606) 647-5609

**SMC Pneumatics Inc. (L.A.)**  
14191 Myford Road  
Tustin, CA 92780  
Tel: (714) 669-1701  
FAX: (714) 669-1715

**SMC Pneumatics Inc. (Portland)**  
14107 N.E. Airport Way  
Portland, OR 97230  
Tel: (503) 252-9299  
FAX: (503) 252-9253

**SMC Pneumatics Inc. (Tulsa)**  
10203 A East 61st Street  
Tulsa, OK 74146  
Tel: (918) 252-7820  
FAX: (918) 252-9511

**Europe**  
ENGLAND  
**SMC Pneumatics (U.K.) Ltd.**  
GERMANY  
**SMC Pneumatik GmbH**  
ITALY  
**SMC Italia SpA**  
FRANCE  
**SMC Pneumatique SA**  
HOLLAND  
**SMC Controls BV**  
SWEDEN  
**SMC Pneumatics Sweden AB**  
SWITZERLAND  
**SMC Pneumatik AG**  
AUSTRIA  
**SMC Pneumatik GmbH**  
SPAIN  
**SMC España, S.A.**  
IRELAND  
**SMC Pneumatics (Ireland) Ltd.**  
**Asia**  
JAPAN

**SMC Corporation**  
KOREA  
**SMC Pneumatics Korea Co., Ltd.**  
CHINA  
**SMC (China) Co., Ltd.**  
HONG KONG  
**SMC Pneumatics (Hong Kong) Ltd.**  
SINGAPORE  
**SMC Pneumatics (S.E.A.) Pte. Ltd.**  
PHILIPPINES  
**SMC Pneumatics (Philippines), Inc.**  
MALAYSIA  
**SMC Pneumatics (S.E.A.) Sdn. Bhd.**  
TAIWAN  
**SMC Pneumatics (Taiwan) Co., Ltd.**  
THAILAND  
**SMC Thailand Ltd.**  
INDIA  
**SMC Pneumatics (India) Pvt., Ltd.**  
**North America**  
CANADA  
**SMC Pneumatics (Canada) Ltd.**  
MEXICO  
**SMC Pneumatics (Mexico) S.A. de C.V.**

**South America**  
ARGENTINA  
**SMC Argentina S.A.**  
CHILE  
**SMC Pneumatics (Chile) Ltda.**

**Oceania**  
AUSTRALIA  
**SMC Pneumatics (Australia) Pty. Ltd.**  
NEW ZEALAND  
**SMC Pneumatics (N.Z.) Ltd.**

## SMC offers the same quality and engineering expertise in many other pneumatic components

**Valves**  
Directional Control Valves  
Manual Valves  
Mufflers  
Exhaust Cleaners  
Quick Exhaust Valves

**Valves**  
Proportional Valves  
Mechanical Valves  
Miniature Valves  
Fluid Valves

**Cylinders/Actuators**  
Compact Cylinders  
Miniature Cylinders  
Rodless Cylinders  
Rotary Actuators  
Pneumatic Grippers

**Vacuum**  
Vacuum Ejectors  
Vacuum Accessories  
**Instrumentation**  
Pneumatic Positioners  
Pneumatic Transducers

**Air Preparation Equipment**  
Filters-Regulators-Lubricators  
Coalescing Filters  
Micro Mist Separators  
**Fittings**  
Air Fittings

## SMC Pneumatics Inc.

P.O. Box 26640, Indianapolis, IN 46226  
Tel: (317) 899-4440 • FAX: (317) 899-3102