

Rotary Table
Vane Type:
Basic

Series MSUB

Sizes 1, 3, 7, 20



How to Order

Bearing type

B	Basic type
---	------------

Free-mount

Connection port position

Nil	Side ports
E	Top ports

Available with side ports only, when equipped with switch unit.

Without Auto Switch Unit

With Auto Switch Unit

Nominal size (torque)

1	MSUB 1
3	MSUB 3
7	MSUB 7
20	MSUB 20

Rotation

Application	Symbol	Rotation
Single vane	90	90°
Double vane	180	180°
Double vane	90	90°

Rotation adjustment range
Single vane: Both ends ±5° each
Double vane: Both ends ±2.5° each

Vane type

S	Single vane
D	Double vane

Number of auto switches

S	1 pc.*
Nil	2 pcs.

* For 1 piece, a right hand auto switch is installed.

Electrical entry/Lead wire length

Nil	Grommet/lead wire 0.5m
L	Grommet/lead wire 3m
C	Connector/lead wire 0.5m
CL	Connector/lead wire 3m
CN	Connector/without lead wire

* Available only with R73, R80 and T79 type connectors.
** Lead wire with connector part nos.
D-LC05: Lead wire 0.5m
D-LC30: Lead wire 3m
D-LC50: Lead wire 5m

Type of auto switch

Nil	Without auto switch
-----	---------------------

* Select applicable auto switches from the table below.

Applicable auto switches/Refer to pages 26 through 35 for detailed auto switch specifications.

Applicable model	Type	Electrical entry	Indicator light	Wiring (output)	Load voltage		Auto switch part no.	Lead wire type	Lead wire length (m)*				Applicable loads																				
					DC	AC			0.5 (Nil)	3 (L)	5 (Z)	None (N)																					
MDSUB1 MDSUB3	Reed	Grommet	No	2 wire	24V	5V, 12V	5V, 12V, 24V	90	Parallel cord	●	●	●	—	Relay, PLC																			
						5V, 12V, 100V	5V, 12V, 24V, 100V	90A	Heavy duty	●	●	●	—																				
						—	100V	93A	Parallel cord	●	●	●	—																				
	Solid state					Yes	3 wire (NPN)	24V	12V	—	—	Heavy duty	—		—	—	—	IC circuit															
																			3 wire (PNP)	5V, 12V	—	—	—	—	—	—	—	—					
																													3 wire (PNP)	5V, 12V	—	—	—
3 wire (PNP)	5V, 12V	—	—	—	—									—																			
																			MDSUB7 MDSUB20	Reed	Grommet	Yes	2 wire	24V	—	100V	R73	Heavy duty	●	●	—	—	
Connector	48V, 100V	24V, 48V, 100V	R80	●	●									●																			●
						Connector	100V	—	R80C	●	●	●	●																				
Solid state	No	Grommet	24V	12V	—									—	Heavy duty	—	—	—		—													IC circuit
						Connector	—	—	—	—	—	—	—																				
Grommet		3 wire (NPN)				5V, 12V	—	—	—	—	—	—	—						—		IC circuit												
																						Grommet	3 wire (PNP)	12V	—	—	—	—	—	—	—	—	

- Order example: MSUA20 single vane type (connection port side position selected)
- Standard type (without auto switches), rotation 90°, side port position MSUB20-90S
 - With switch unit (without auto switches), rotation 180°, side port position MDSUB20-180S
 - With switch unit + auto switch R73, rotation 180°, side port position MDSUB20-180S-R73

* Lead wire length symbols 0.5m Nil (Example) R73C ● Operating time ——— 1.2ms ● Operating temperature range ——— 5 to 60°C (41 to 140°F)
3m L (Example) R73CL ● Impact resistance ——— 300m/s² (reed), 1000m/s² (solid state)
5m Z (Example) R73CZ
None N (Example) R73CN

Specifications

Model 3°	MSUB1		MSUB3		MSUB7		MSUB20			
Vane type	Single vane	Double vane	Single vane	Double vane	Single vane	Double vane	Single vane	Double vane		
Rotation 1°	90°±10°	180°±10°	90°±5°	90°±10°	180°±10°	90°±5°	90°±10°	180°±10°	90°±5°	
Fluid	Air (unlubricated)									
Proof pressure MPa (psi)	1.05 (152.25psi)						1.5 (217.5psi)			
Ambient and fluid temperature	5 to 60°C (41 to 140°F)									
Operating pressure range MPa (psi)	0.2 to 0.7(29 to 101.5)		0.15 to 0.7(21.75 to 101.5)			0.15 to 1.0 (21.75 to 145)				
Rotation time adjustment range sec/90°	0.07 to 0.3 seconds per 90°									
Shaft load	Allowable radial load		20N (4.4lbf)		40N (8.9lbf)		50N (11.2lbf)		60N (13.4lbf)	
	Allowable thrust load 2°		15N (3.3lbf)		30N (6.7lbf)		60N (13.4lbf)		80N (17.9lbf)	
			10N (2.2lbf)		15N (3.3lbf)		30N (6.7lbf)		40N (8.9lbf)	
Allowable moment		0.3N·m (2.65lbf·in)		0.7N·m (6.19lbf·in)		0.9N·m (7.96lbf·in)		2.9N·m (25.66lbf·in)		
Bearing	Bearings									
Port position	Side ports or Top ports									
Port size	Side ports		M3 x 0.5		M5 x 0.8 (10 - 32 nominal)					
	Top ports		M3 x 0.5			M5 x 0.8 (10 - 32 nominal)				

*1. Single vane 90° type can be adjusted to 90°±10° (both ends of rotation ±5° each)
 Single vane 180° type can be adjusted to 180°±10° (both ends of rotation ±5° each)
 Double vane 90° type can be adjusted to 90°±5° (both ends of rotation ±2.5° each)
 * Rotation angles other than 90° and 180° (single vane) are available by special order.

*2. The allowable thrust load is directional. For details refer to the allowable load table below.

(Note) Refer to page 39 for allowable kinetic energy.

*3. Correspondence to equivalent conventional free-mount types

Rotary table	Free-mount rotary actuator
MSUB 1	CRBUW10
MSUB 3	CRBUW15
MSUB 7	CRBUW20
MSUB20	CRBUW30

Table Rotation Range

Angle adjustment is possible as shown in the drawings below using adjustment bolts (A) and (B).

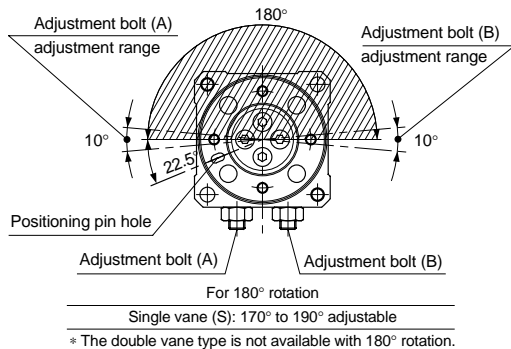
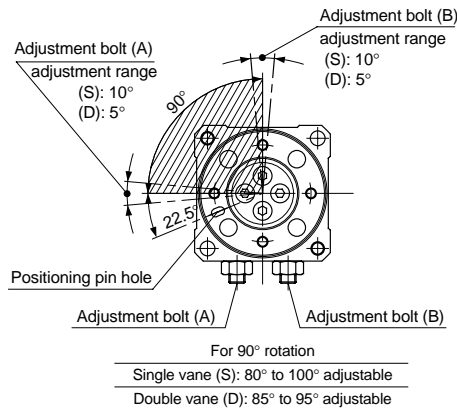

Note: 1MPa = 145psi
 1N = 0.2248lbf
 1N·m = 8.85lbf·in
 1in = 25.4mm

Applicable Auto Switches

Auto switch type	MDSUB1, 3	MDSUB7, 20
Reed switch	D-90/97, D-90A/93A	D-R7, R8
Solid state switch	D-S99, D-T99, D-S9P	D-S7, D-S7P, T7

Weights

Unit: g (oz)

Size	Rotation	Basic weight		Auto switch unit + Auto switch 2 pcs.
		Single vane	Double vane	
1	90	145	150	25
	180	140	—	
3	90	230	240	30
	180	225	—	
7	90	360	375	50
	180	355	—	
20	90	510	580	60
	180	505	—	

Allowable Loads

Do not permit the load and moment applied to the table to exceed the allowable values shown in the table below. (Operation above the allowable values can cause adverse effects on service life, such as play in the table and loss of accuracy.)

Size	Allowable radial load N (lb)	Allowable thrust load N (lb)	Allowable moment N (lb)
1	20 (4.49)	Ⓐ15 (3.37) Ⓑ10 (2.24)	0.3 (2.65)
3	40 (8.49)	30 (6.74) 15 (3.37)	0.7 (6.19)
7	50 (11.24)	60 (13.48) 30 (6.74)	0.9 (7.96)
20	60 (13.48)	80 (17.98) 40 (8.99)	2.9 (25.66)

Dimensions (mm)

These drawings indicate the condition when the B port is pressurized.

1 in = 25.4mm

MSUB1 (Single vane)

MSUB1-□S, SE

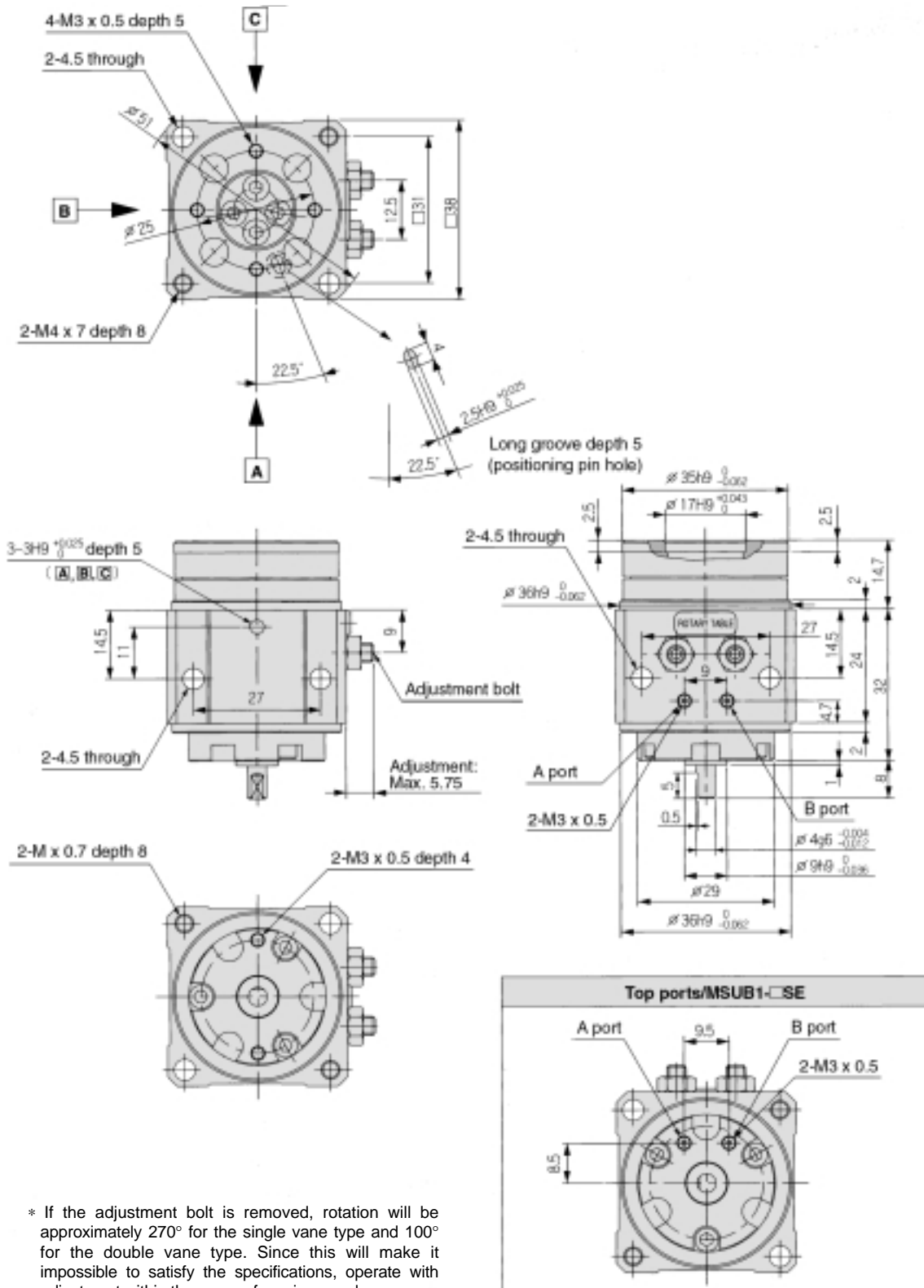

* If the adjustment bolt is removed, rotation will be approximately 270° for the single vane type and 100° for the double vane type. Since this will make it impossible to satisfy the specifications, operate with adjustment within the range of maximum values.

Dimensions (mm)

These drawings indicate the condition when the B port is pressurized.

1in = 25.4mm

With auto switch: MDSUB1-□S

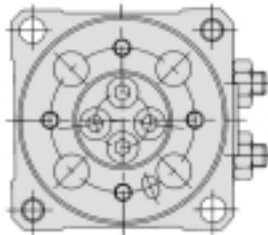

- *1) When using 24 : D-90, 90A, S99(V), T99(V), S9P(V)
When using 30 : D-97, 93A
- *2) When using 60° : D-90, 90A, 97, 93A
When using 69° : D-S99(V), T99(V), S9P(V)

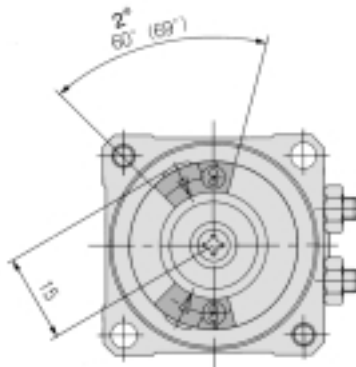
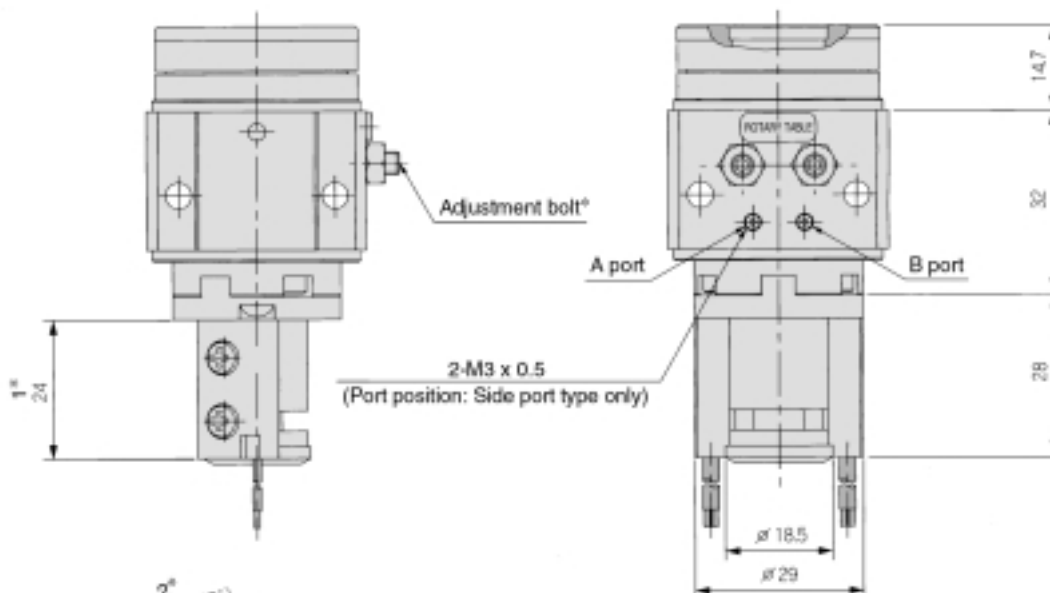

D-97, 93A

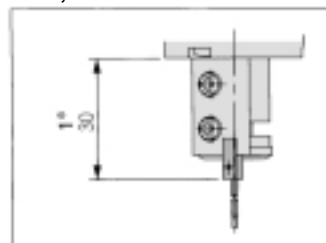

* If the adjustment bolt is removed, rotation will be approximately 270° for the single vane type and 100° for the double vane type. Since this will make it impossible to satisfy the specifications, operate with adjustment within the range of maximum values.

Dimensions (mm)

These drawings indicate the condition when the B port is pressurized.

1in = 25.4mm

MSUB1 (Double vane) MSUB1-□D

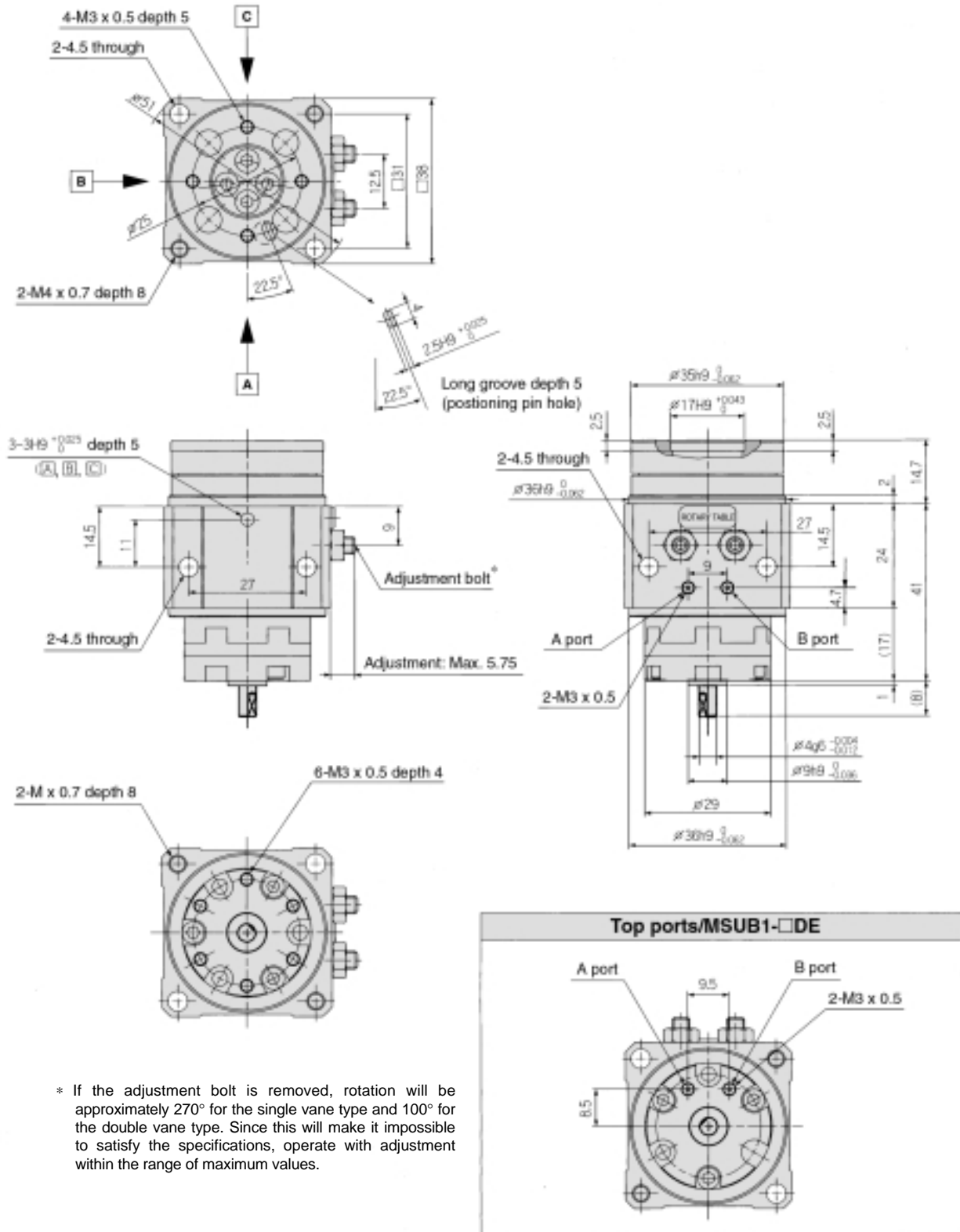

* If the adjustment bolt is removed, rotation will be approximately 270° for the single vane type and 100° for the double vane type. Since this will make it impossible to satisfy the specifications, operate with adjustment within the range of maximum values.

Dimensions (mm)

These drawings indicate the condition when the B port is pressurized.

1in = 25.4mm

With auto switch: MDSUB1-□D

- *1)°When using 24 : D-90, 90A, S99(V), T99(V), S9P(V)
When using 30 : D-97, 93A
- *2)°When using 60°: D-90, 90A, 97, 93A
When using 69°: D-S99(V), T99(V), S9P(V)

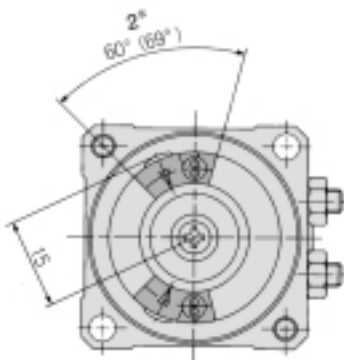
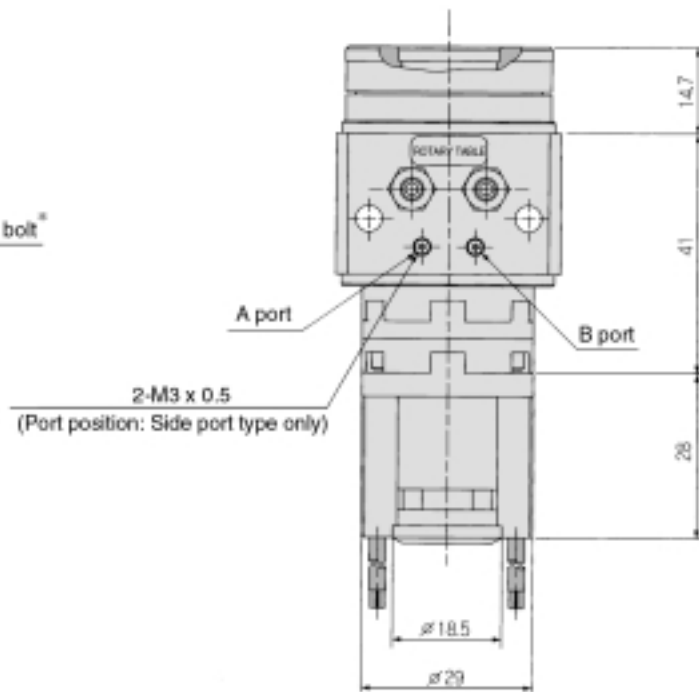
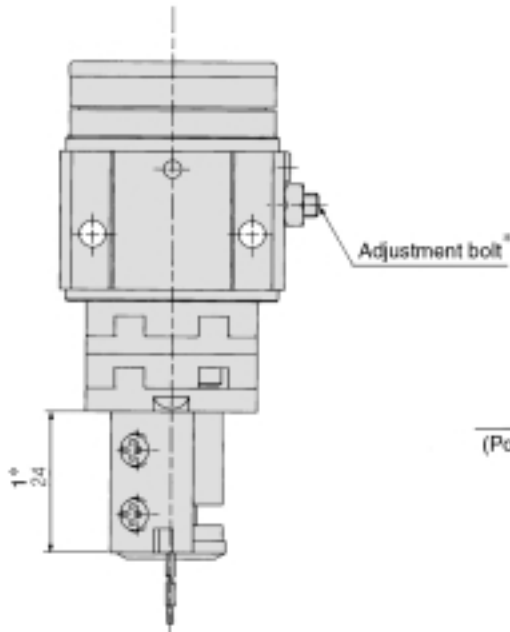
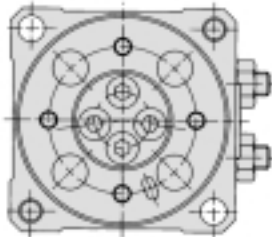

D-97, 93A

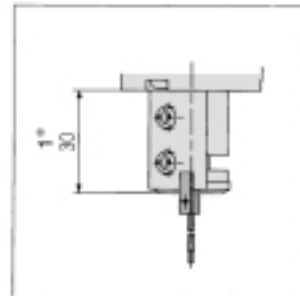

* If the adjustment bolt is removed, rotation will be approximately 270° for the single vane type and 100° for the double vane type. Since this will make it impossible to satisfy the specifications, operate with adjustment within the range of maximum values.

Dimensions (mm)

These drawings indicate the condition when the B port is pressurized.

1in = 25.4mm

MSUB3 (Single vane, Double vane)

MSUB3-□S, D

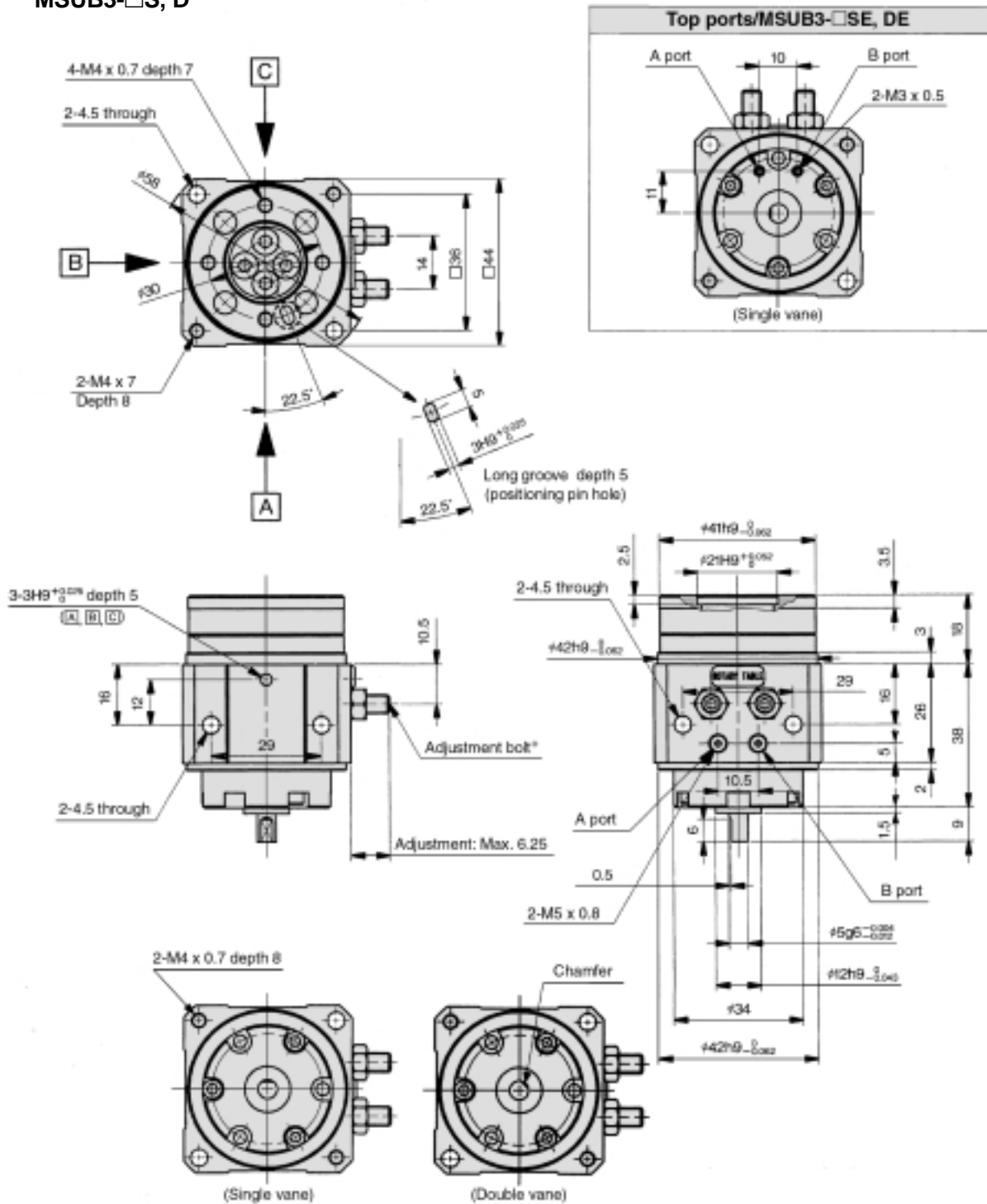

The outside drawings show the single vane type, but only the position of the chamfered sections shown in the above drawings differs for single and double vane.

* If the adjustment bolt is removed, rotation will be approximately 270° for the single vane type and 100° for the double vane type. Since this will make it impossible to satisfy the specifications, operate with adjustment within the range of maximum values.

Dimensions (mm)

These drawings indicate the condition when the B port is pressurized.

1 in = 25.4mm

With auto switch: MDSUB3

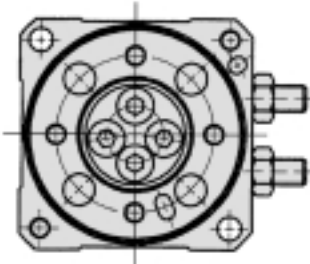

- *1) When using 24 : D-90, 90A, S99(V), T99(V), S9P(V)
When using 30 : D-97, 93A
- *2) When using 60° : D-90, 90A, 97, 93A
When using 69° : D-S99(V), T99(V), S9P(V)

* If the adjustment bolt is removed, rotation will be approximately 270° for the single vane type and 100° for the double vane type. Since this will make it impossible to satisfy the specifications, operate with adjustment within the range of maximum values.

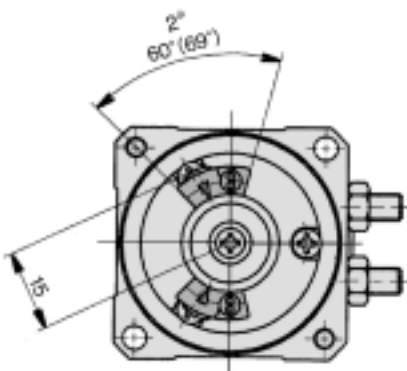
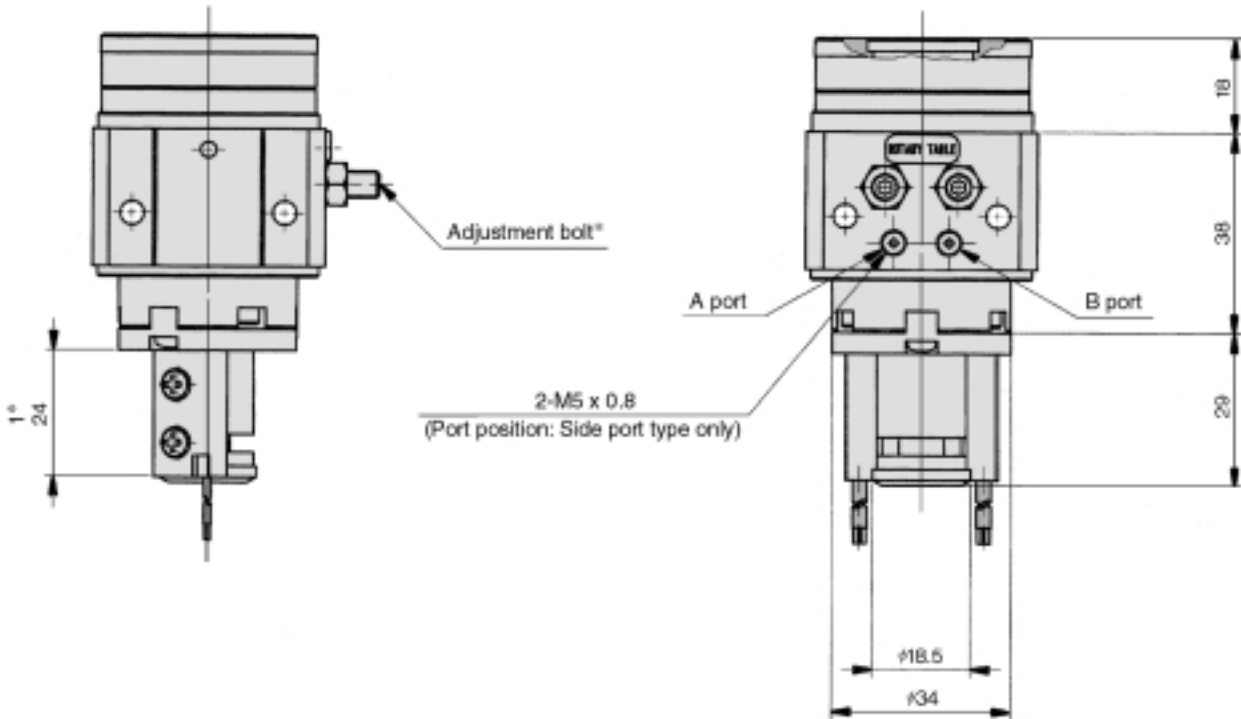

D-97, 93A

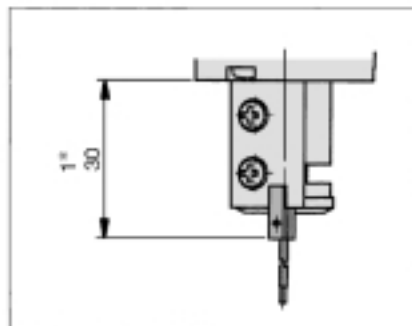

Dimensions (mm)

These drawings indicate the condition when the B port is pressurized.

1 in = 25.4mm

MSUB7 (Single vane, Double vane)

MSUB7-□S, D

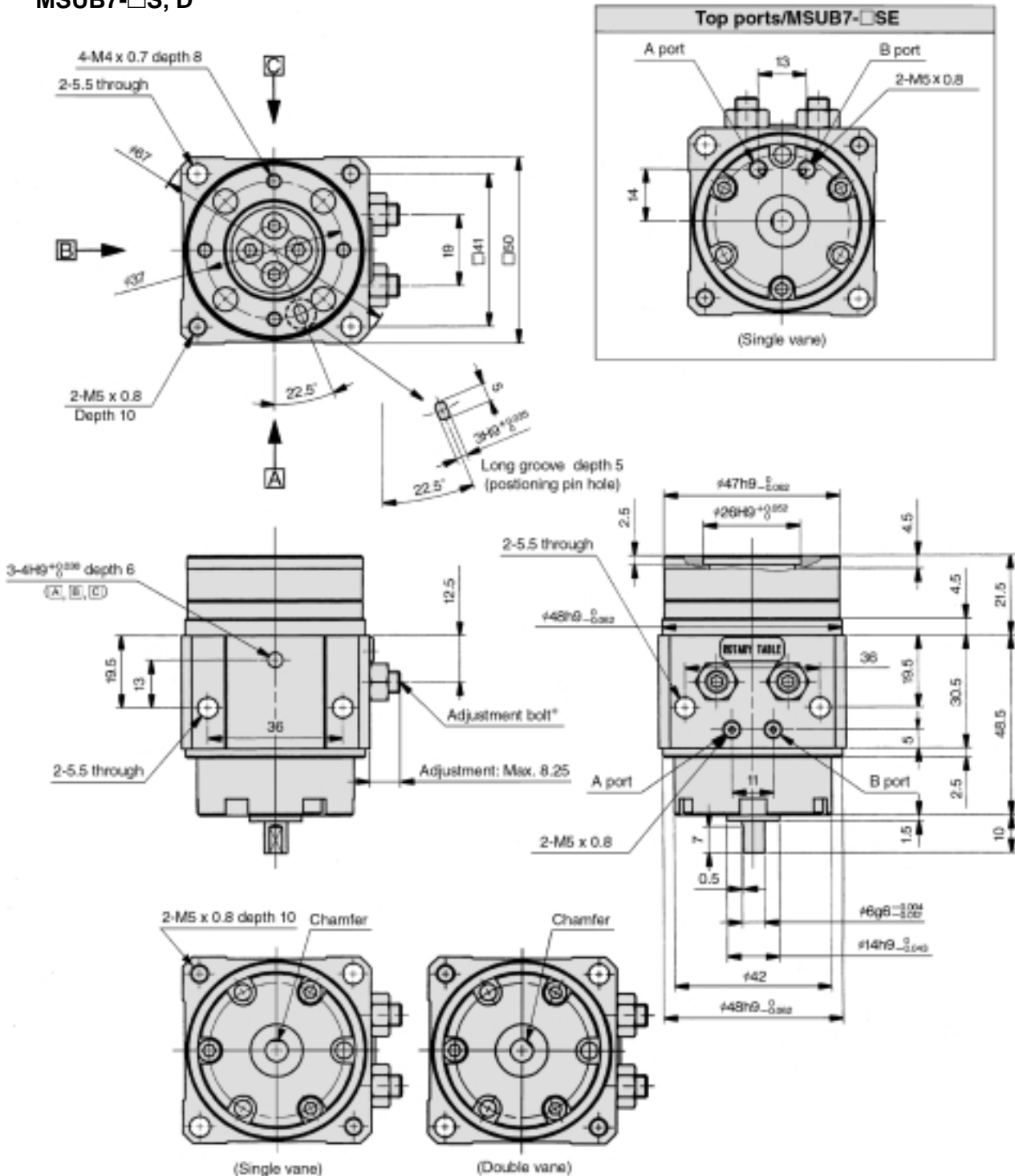

The outside drawings show the single vane type, but only the position of the chamfered sections shown in the above drawings differs for single and double vane.

* If the adjustment bolt is removed, rotation will be approximately 270° for the single vane type and 100° for the double vane type. Since this will make it impossible to satisfy the specifications, operate with adjustment within the range of maximum values.

Dimensions (mm)

These drawings indicate the condition when the B port is pressurized.

1 in = 25.4mm

With auto switch: MDSUB7

- *1) 25.5: Grommet type
34.5: Connector type
- *2) 20.5: Grommet type
26.5: Connector type

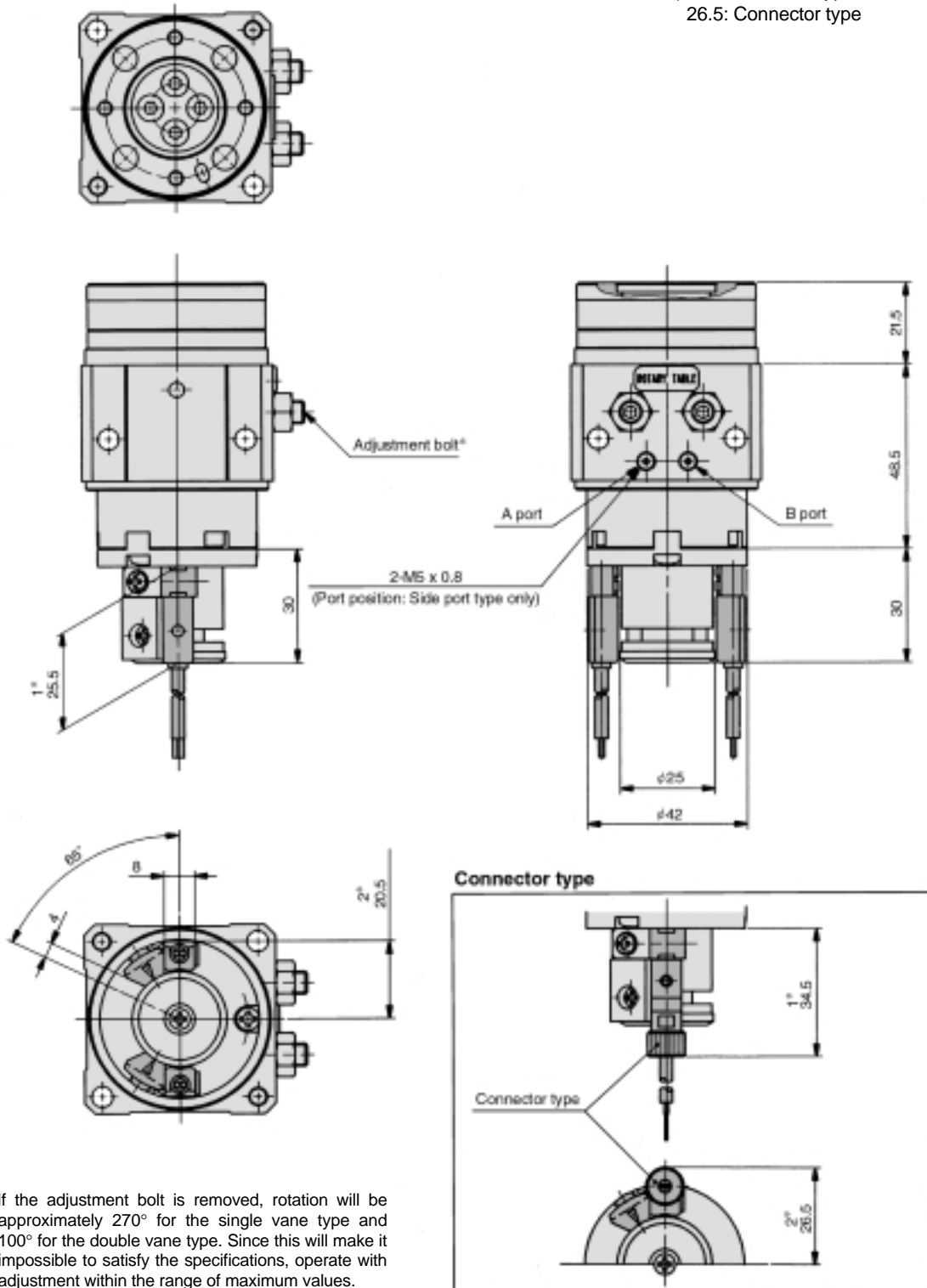

* If the adjustment bolt is removed, rotation will be approximately 270° for the single vane type and 100° for the double vane type. Since this will make it impossible to satisfy the specifications, operate with adjustment within the range of maximum values.

Dimensions (mm)

These drawings indicate the condition when the B port is pressurized.

1 in = 25.4mm

MSUB20 (Single vane, Double vane)

MSUB20-□S, D

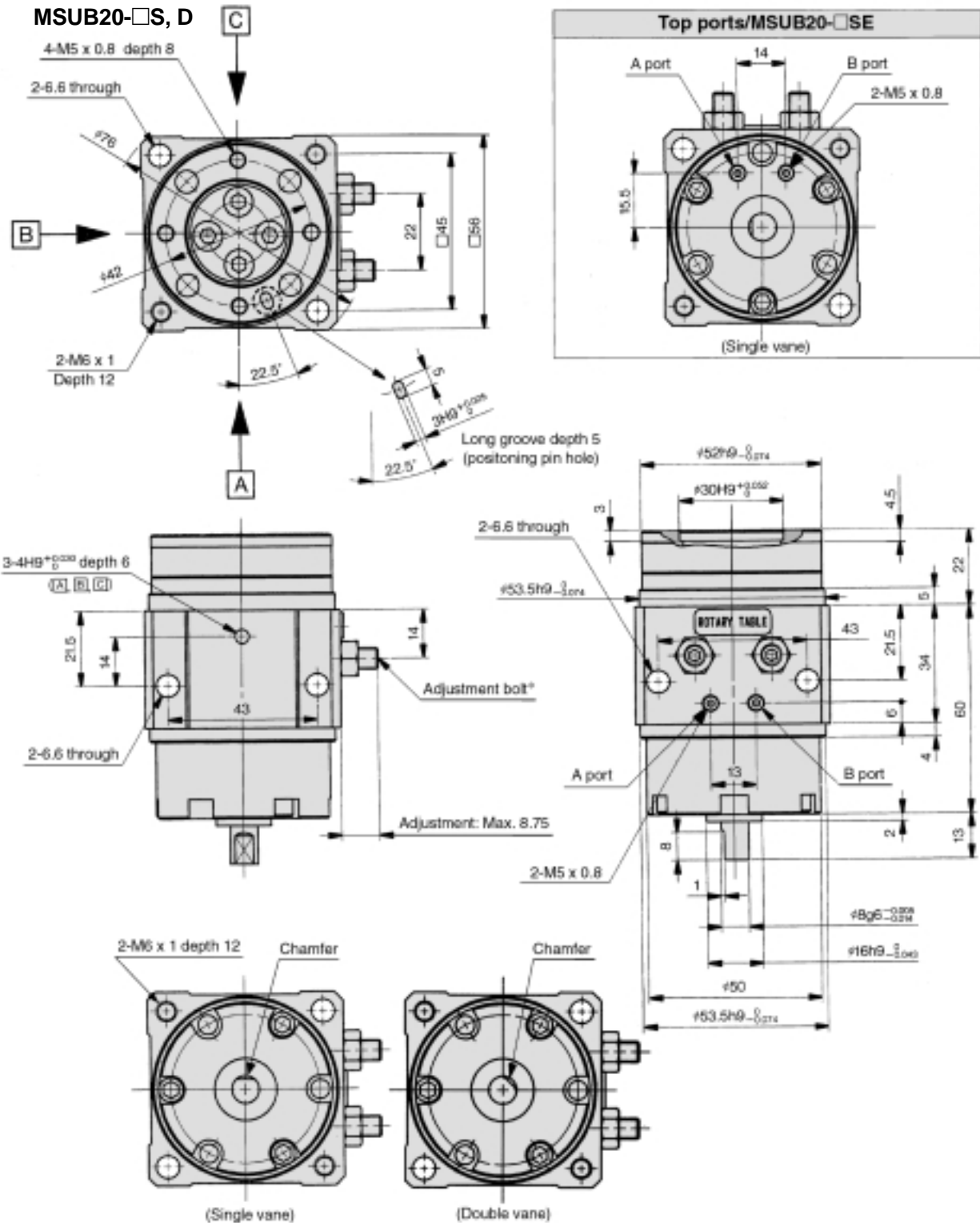

The outside drawings show the single vane type, but only the position of the chamfered sections shown in the above drawings differs for single and double vane.

* If the adjustment bolt is removed, rotation will be approximately 270° for the single vane type and 100° for the double vane type. Since this will make it impossible to satisfy the specifications, operate with adjustment within the range of maximum values.

Dimensions (mm)

These drawings indicate the condition when the B port is pressurized.

1in = 25.4mm

With auto switch: MDSUB20

- *1) 25.5: Grommet type
34.5: Connector type
- *2) 20.5: Grommet type
26.5: Connector type

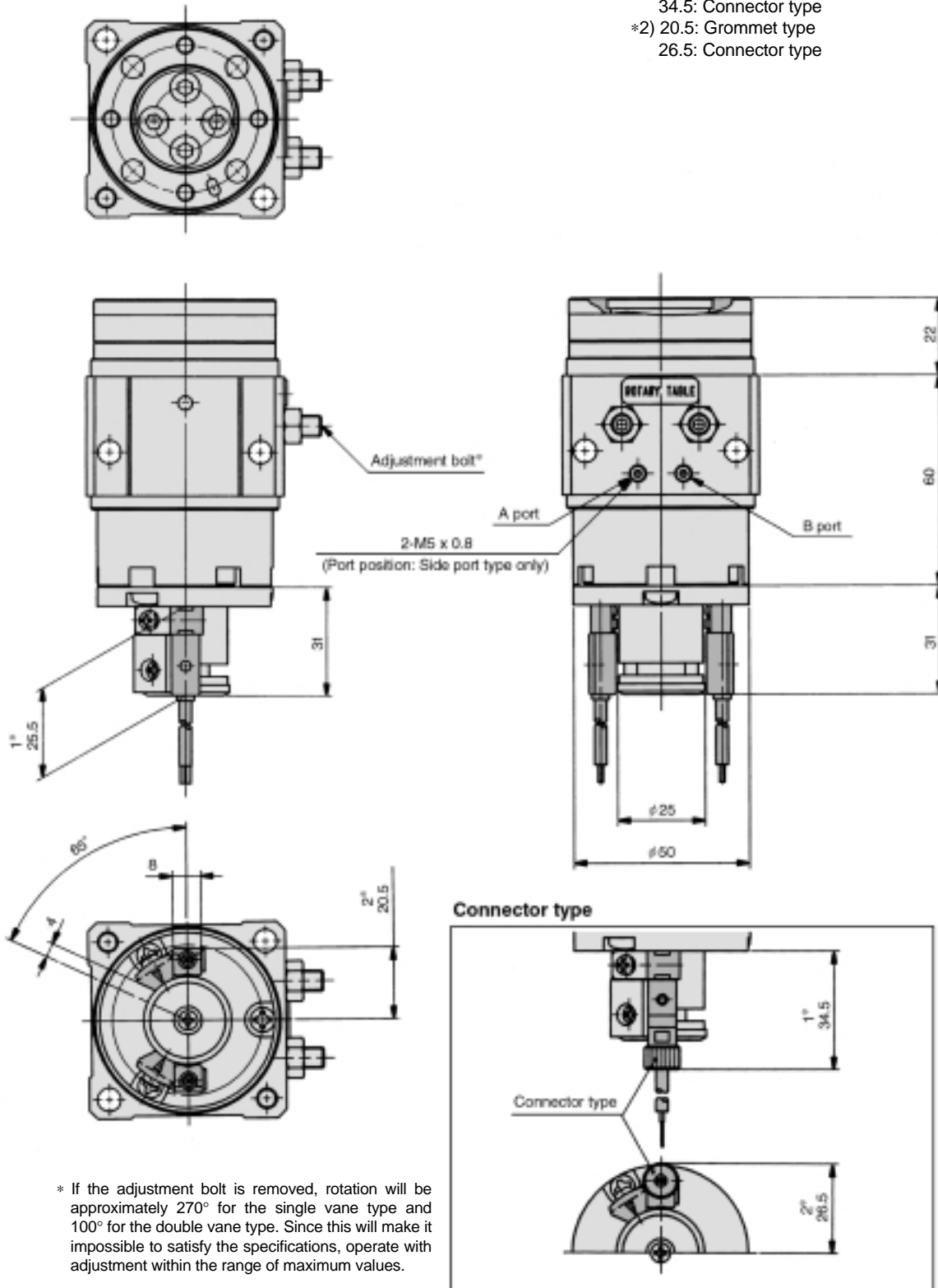

* If the adjustment bolt is removed, rotation will be approximately 270° for the single vane type and 100° for the double vane type. Since this will make it impossible to satisfy the specifications, operate with adjustment within the range of maximum values.

Construction/Parts List

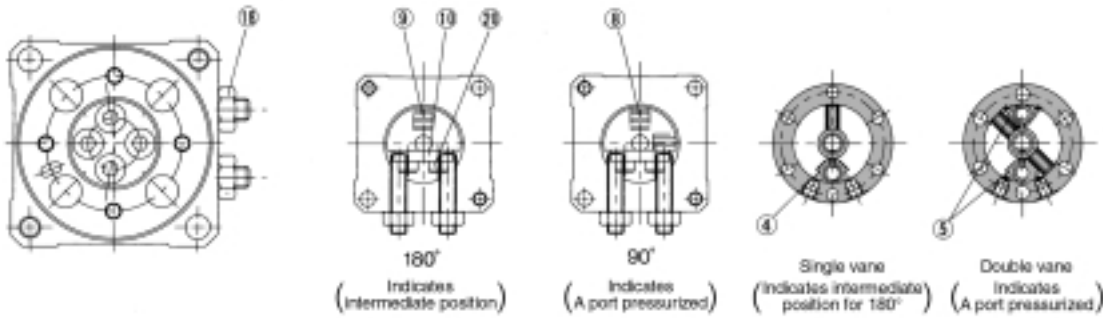

Single vane: Size 1

Single vane: Sizes 3, 7, 20

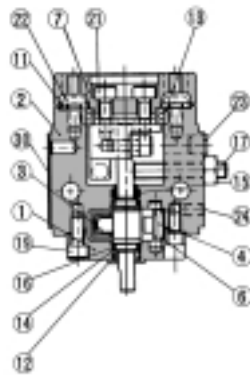
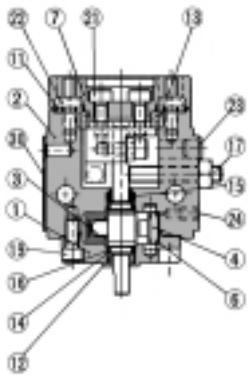

Double vane: Size 1

Double vane: Sizes 3, 7, 20

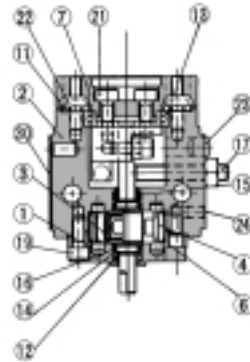
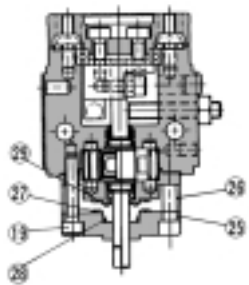

Parts list

No.	Description	Material	Note
1	Body (A)	Aluminum alloy	Light gray color
2	Body (B)	Aluminum alloy	Light gray color
3	Vane shaft	Stainless steel (MSUB20: Carbon steel)	Single vane
4	Stopper	Carbon steel	Double vane
5	Stopper	Resin	Single vane
6	Stopper seal	Stainless steel	Double vane
7	Table	NBR	
8	Stopper lever (D)	Aluminum alloy	Light gray color
9	Stopper lever (S)	Carbon steel	
10	Lever retainer	Carbon steel	
11	Ring collar	Carbon steel	
12	Bearing	High carbon chrome bearing steel	
13	Bearing	High carbon chrome bearing steel	
14	Back-up ring	Stainless steel	
15	Scraper	Carbon steel	
16	O-ring	NBR	
17	Adjustment bolt	NBR	
18	Hexagon nut	Carbon steel	
19	Hexagon socket head cap screw	Stainless steel	
20	Hexagon socket head cap screw	Stainless steel	
21	Hexagon socket head cap screw	Stainless steel	
22	Button bolt	Carbon steel	
23	Rubber cap	NBR	
24	Hexagon socket head set screw	Stainless steel	
25	Cover	Aluminum alloy	SE type only
26	Plate	Resin	
27	Gasket	NBR	
28	O-ring	NBR	
29	O-ring	NBR	
30	Label		

* The plug number 24 is used only when the connection port is type SE.

Internal construction with auto switch

Units are common for both single and double vane.

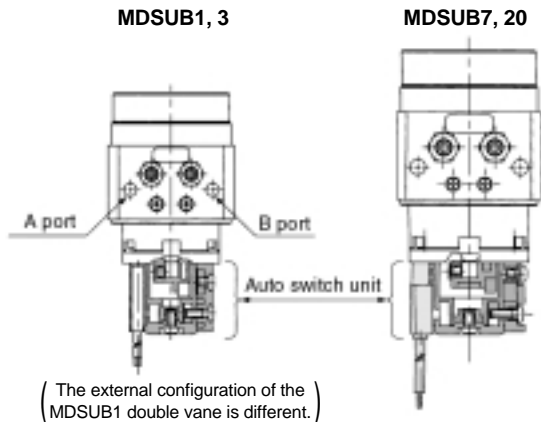

Model	Auto switch unit part no.
MDSUB 1	P211070-1
MDSUB 3	P211090-1
MDSUB 7	P211060-1
MDSUB20	P211080-1

* Auto switches are not included with switch units.

Auto switch block unit		
For MDSUB1, 3		For MDSUB7, 20
Right-handed	Left-handed	Combination left & right-handed
Part no.: P211070-8	Part no.: P211070-9	Part no.: P211060-8

* A switch block unit is the assembly required to mount one auto switch on a switch unit.

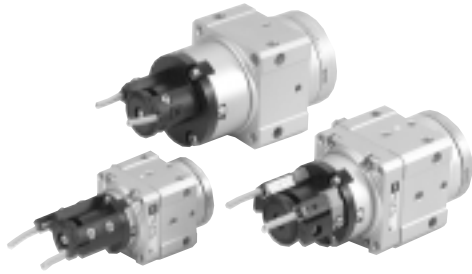

Applicable auto switches

Applicable series	Auto switch model	Electrical entry
MDSU□1 MDSU□3	Reed switch	D-90, 90A
		D-97, 93A
	Solid state switch	D-S99, S99V
		D-S9P, S9PV
MDSU□7 MDSU□20	Reed switch	D-R73
		D-R80
	Solid state switch	D-S79
		D-S7P
		D-T79

Table Positioning Pin Hole Rotation Range and Auto Switch Mounting Position

MSU□1, 3

Single vane type
90°

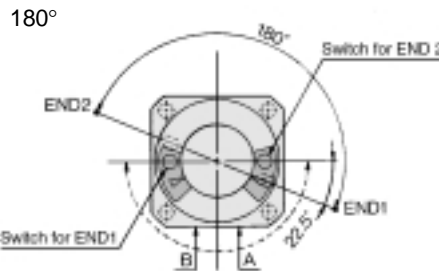
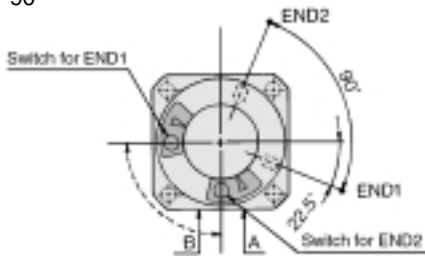

Double vane type (MSUB only)
90°

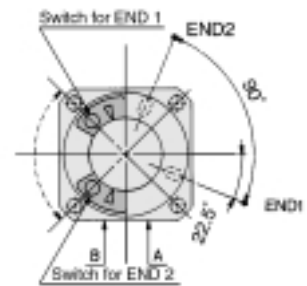

MSU□7, 20

Single vane type
90°

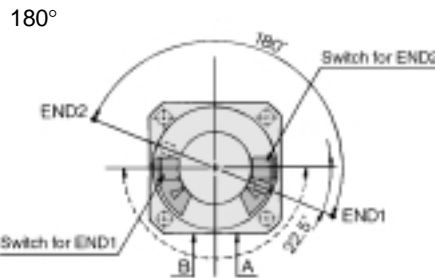
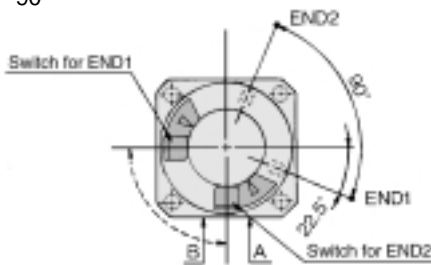

Double vane type (MSUB only)
90°

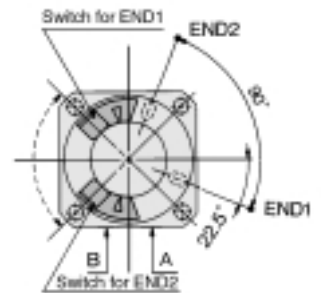

- In drawings that show the rotation range, the arrows on the solid line 90° (180°) indicate the rotation range of the positioning pin holes on the table surface. When the pin hole is at END1, the END1 switch operates, and when the pin hole is at END2, the END2 switch operates.
- The arrows on the broken line indicate the rotation range of the internal magnet. The rotation range of each switch can be reduced by moving the END1 switch clockwise and the END2 switch counterclockwise.

Auto switch rotation and actuation ranges

Model	Rotation range	Actuation range
MDSU□1, 3	110°	10°
MDSU□7, 20	90°	

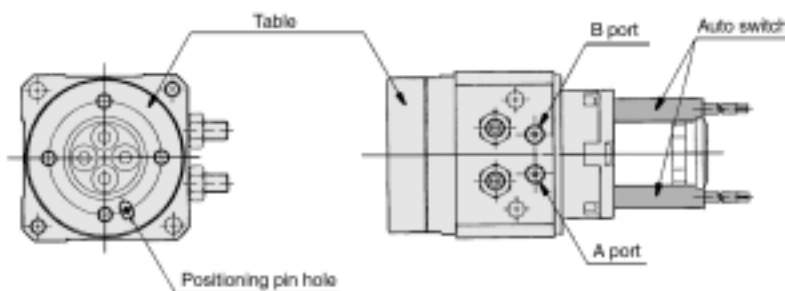

How to change Auto switch Detecting Positions

To set a new detection position, slightly loosen the set screw, move the switch to the desired position and retighten the screw. Over-tightening can damage the screw making it impossible to hold the position. Use a tightening torque of about 0.5N·m.

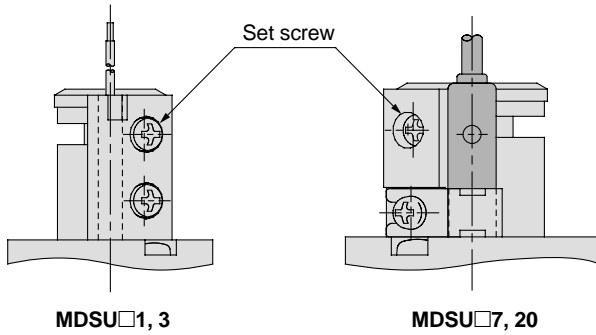

Auto Switch Mounting Classifications

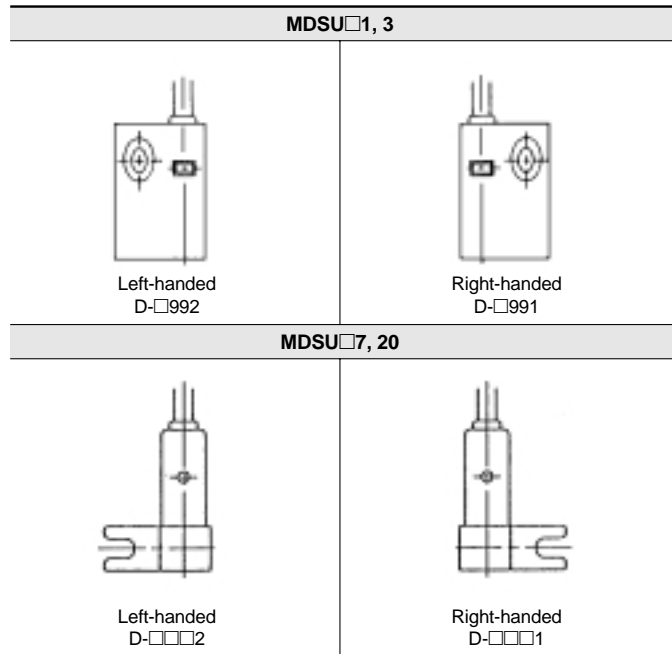

Auto Switch Units



Auto switch unit part numbers

Model	Unit part number
MDSU□ 1	P211070-1
MDSU□ 3	P211090-1
MDSU□ 7	P211060-1
MDSU□20	P211080-1

*The magnet lever is included.

Auto switch block units

MDSU□1, 3		MDSU□7, 20
Right-handed	Left-handed	Combination left & right-handed
Part no.: P211070-8	Part no.: P211070-9	Part no.: P211060-8

* A switch block unit is the assembly required to mount one switch on a switch unit.

⚠ Caution

Be sure to read before handling.
Refer to pages 45 through 47
before using auto switches.

Auto Switch Common Specifications

Type	Reed switch	Solid state switch
Leakage current	None	3 wire: 100μA or less, 2 wire: 0.8mA or less
Operating time	1.2ms	1ms or less
Impact resistance	300m/s ² (3.5G)	1000m/s ² (101.9G)
Insulation resistance	50MΩ or more at 500VDC (between lead wire and case)	
Withstand voltage	1500VAC for 1 min.*1) (between lead wire and case)	1000VAC for 1 min. (between lead wire and case)
Ambient temperature	-10 to 60°C (14 to 140°F)	
Enclosure	IEC529 standard IP67, JISC0920 watertight construction	

*1) Electrical entry: Connector type (R73C, R80C) and D-9, 9□A, A9 and A9□V are 1000VAC for 1 min. (between lead wire and case)

Lead Wire Length

Lead wire length indication

(Example) **D-90A L**

Lead wire length

Nil	0.5m (1.6')
L	3m (9.8')
Z	5m (16.4')
N*	None

* Applicable only for connector type switch D-□□C.

Note 1) Lead wire length Z: 5m applicable auto switches
Reed: D-90/97/90A/93A, D-R73C/R80C
Solid state: All types are produced upon receipt of order (standard availability).

Lead wire with connector part number
(applicable only for connector type)

Model	Lead wire length
D-LC05	0.5m (1.6ft)
D-LC30	3m (9.8ft)
D-LC50	5m (16.4ft)

Contact Protection Boxes/CD-P11, CD-P12

<Applicable switches>

D-R73(C)/R80(C), D-9, 9□A

The above auto switches do not have internal contact protection circuits.

1. The operating load is an induction load.
2. The length of wiring to the load is 5m or more.
3. The load voltage is 100 or 200VAC.

Use a contact protection box in any of the above situations.

The life of the contacts may otherwise be reduced. (They may stay ON all the time.)

Contact protection box specifications

Part number	CD-P11		CD-P12
	Load voltage	100VAC	200VAC
Maximum load current	25mA	12.5mA	50mA

* Lead wire length— Switch connection side 0.5m
Load connection side 0.5m



Contact protection box internal circuits

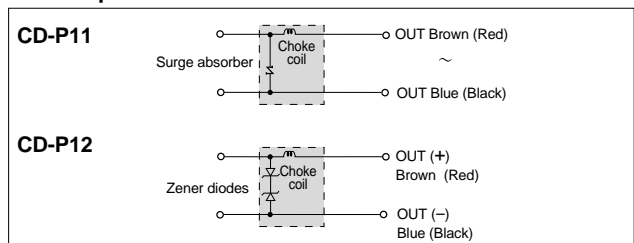

Lead wire colors inside () are those prior to conformity with IEC standards.

Contact protection box/Dimensions

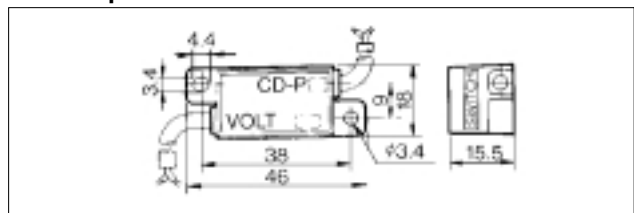

Contact protection box/Connection

To connect a switch to a contact protection box, connect the lead wire from the side of the contact protection box marked SWITCH to the lead wire coming out of the switch. Furthermore, the switch unit should be kept as close as possible to the contact protection box, with a lead wire length of no more than 1 meter between them.

Grommet
Lead wire: Parallel cord

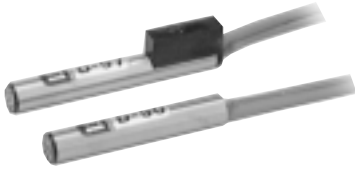

Auto switch internal circuits

Lead wire colors inside () are those prior to conformity with IEC standards.

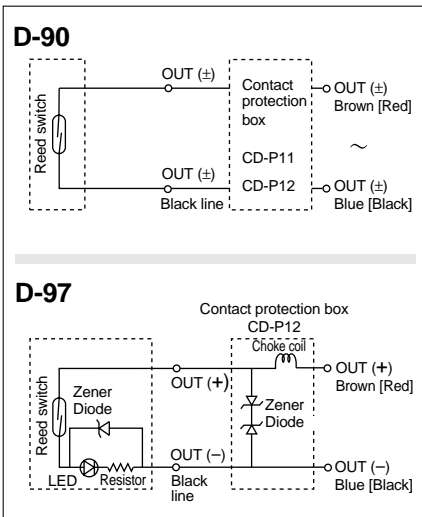

Note) 1. The load is an induction load
2. The lead wire length to the load is 5m or more
Use a contact protection box in either of the above situations, as the life of the contacts may otherwise be reduced. (Refer to page 28 for details regarding contact protection boxes.)

Auto Switch Specifications

D-90 (without indicator light)

Auto switch part no.	D-90		
Application	Relay, IC circuit, PLC		
Load voltage	5V ^{AC} DC	12V ^{AC} DC	24V ^{AC} DC
Maximum load current	50mA		
Internal resistance	1Ω or less (including lead wire length of 3m)		

D-97 (with indicator light)

Auto switch part no.	D-97		
Application	Relay, PLC		
Load voltage	24VDC		
Load current range	5 to 40mA		
Internal voltage drop	2.4V or less		

• Lead wire ——— Vinyl parallel cord, 0.2mm², 2 wire, 0.5m
Note 1) Refer to page 28 for auto switch common specifications
Note 2) Refer to page 28 for lead wire length.

Dimensions (mm)

D-90

1in = 25.4mm

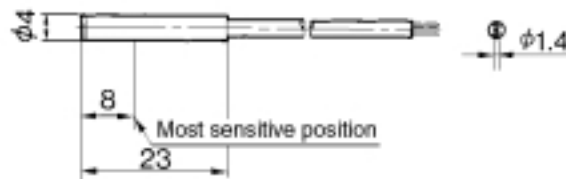

D-97

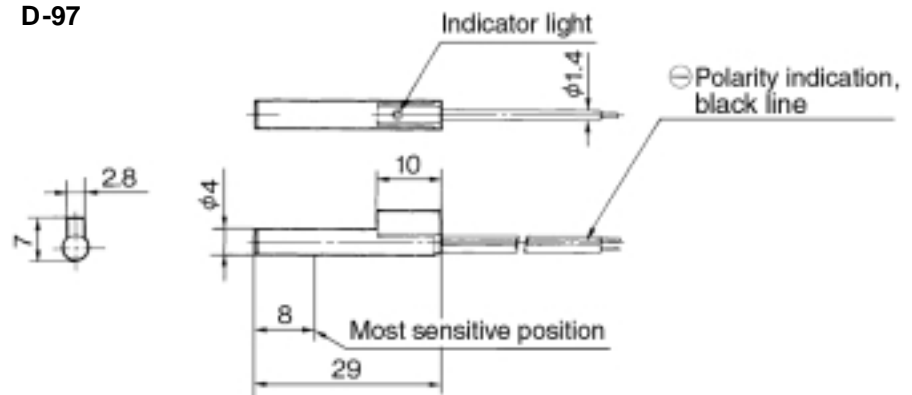

Grommet
Lead wire: Heavy duty cord



Auto Switch Specifications

D-90A (without indicator light)

Auto switch part no.	D-90A			
Applicable load	Relay, IC circuit, PLC			
Load voltage	5V ^{AC} _{DC}	12V ^{AC} _{DC}	24V ^{AC} _{DC}	100V ^{AC} _{DC}
Maximum load current	50mA			20mA
Internal resistance	1Ω or less (including lead wire length of 3m)			

D-93A (with indicator light)

Auto switch part no.	D-93A	
Application	Relay, PLC	
Load voltage	24VDC	100VAC
Load current range	5 to 40mA	5 to 20mA
Internal voltage drop	2.4V or less	
Indicator light	Red LED lights up when ON	

• Lead wires — Oil resistant vinyl heavy duty cord, 0.2mm², 2 wire [Brown, Blue (Red, Black)], 0.5m

Note 1) Refer to page 28 for reed switch common specifications.

Note 2) Refer to page 28 for lead wire length.

Auto switch internal circuits

Lead wire colors inside () are those prior to conformity with IEC standards.

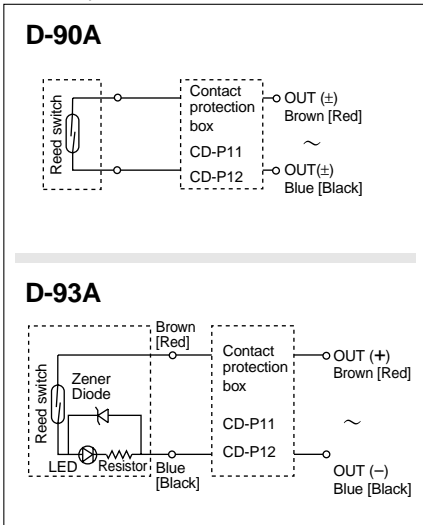

- Note) 1. The load is an induction load
2. The lead wire length to the load is 5m or more
3. The load voltage is 100VAC

Use a contact protection box in any of the above situations, as the life of the contacts may otherwise be reduced. (Refer to page 28 for details regarding contact protection boxes.)

Dimensions (mm)

D-90A

1in = 25.4mm

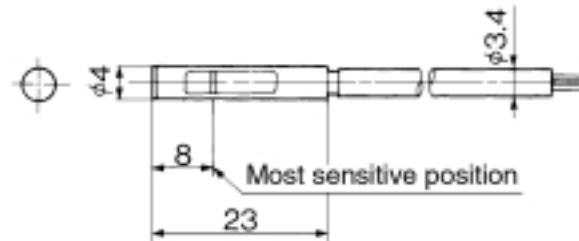

D-93A

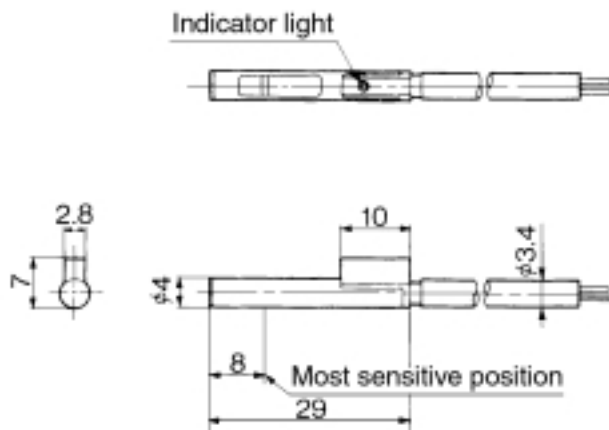

Grommet
Electrical entry direction: In-line

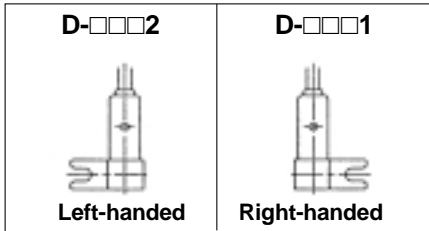

Auto switch internal circuits

Lead wire colors inside () are those prior to conformity with IEC standards.

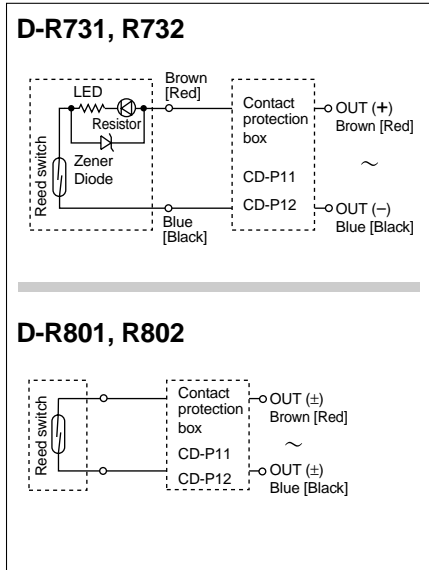

Auto Switch Specifications

D-R73□ (with indicator light)

Auto switch part no.	D-R73C, D-R73Z	
Applicable load	Relay, PLC	
Load voltage	100VAC	24VDC
Maximum load current and load current range	5 to 20mA	5 to 40mA
Contact protection circuit	None	
Internal voltage drop	2.4V or less	
Indicator light	Red LED lights up when ON	

D-R80□ (without indicator light)

Auto switch part no.	D-R801, D-R802		
Applicable loads	Relay, IC circuit, PLC		
Load voltage	24V ^{AC} _{DC} or less	48V ^{AC} _{DC}	100V ^{AC} _{DC}
Maximum load current and load current range	50mA	40mA	20mA
Contact protection circuit	None		
Internal voltage drops	0		
Indicator light	None		

• Lead wires — Oil resistant vinyl heavy duty cord, 0.2mm², 2 wire [Brown, Blue (Red, Black)], 0.5m
 Note 1) Refer to page 28 for reed switch common specifications.
 Note 2) Refer to page 28 for lead wire length.

Dimensions (mm)

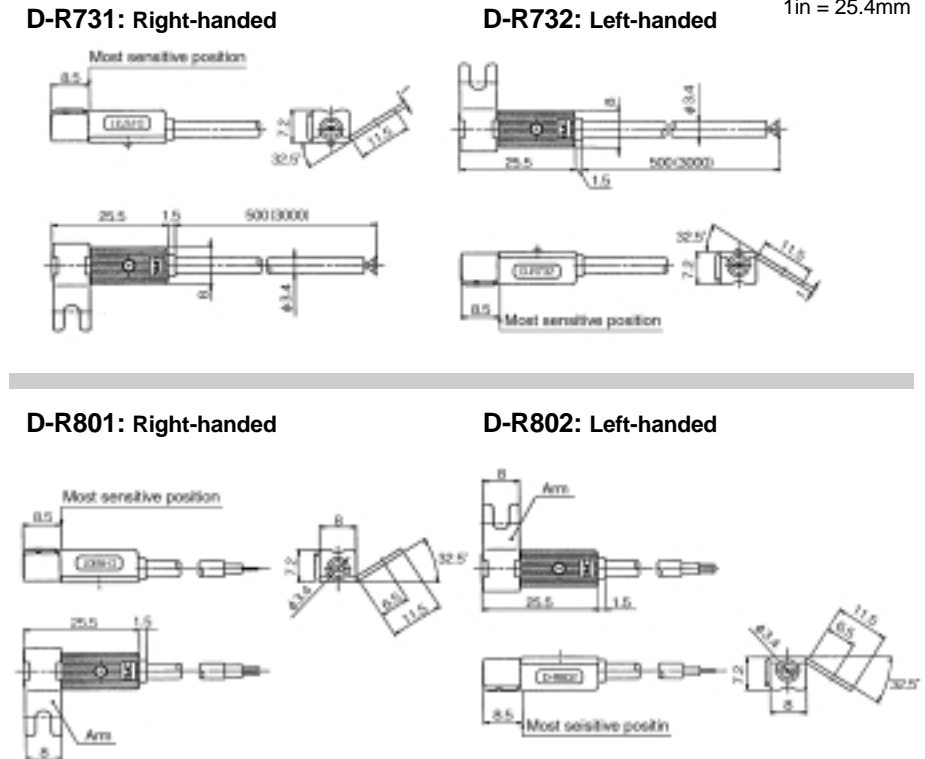

Reed Switches/Direct Mount Type D-R73□C, D-R80□C

Connector
Electrical entry direction: In-line



Auto Switch Specifications

D-R73□C (with indicator light)

Auto switch part no.	D-R731C, D-R732C
Applicable load	Relay, PLC
Load voltage	24VDC
Load current range	5 to 40mA
Contact protection circuit	None
Internal voltage drop	2.4V or less
Indicator light	Red LED lights up when ON

D-R80□C (without indicator light)

Auto switch part no.	D-R801C, D-R802C
Applicable load	Relay, PLC
Load voltage	24V _{DC} ^{AC} or less
Load current range	50mA
Contact protection circuits	None
Internal voltage drops	0
Indicator light	None

• Lead wires — Oil resistant vinyl heavy duty cord, $\phi 3.4$, 0.2mm²
 Note 1) Refer to page 28 for reed switch common specifications.
 Note 2) Refer to page 28 for lead wire length.

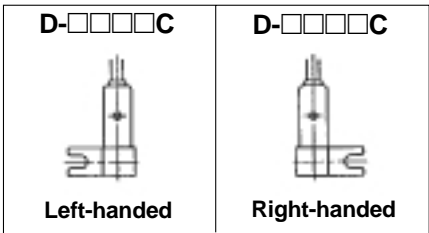

Dimensions (mm)

D-R731C: Right-handed

D-R732C: Left-handed

1in = 25.4mm

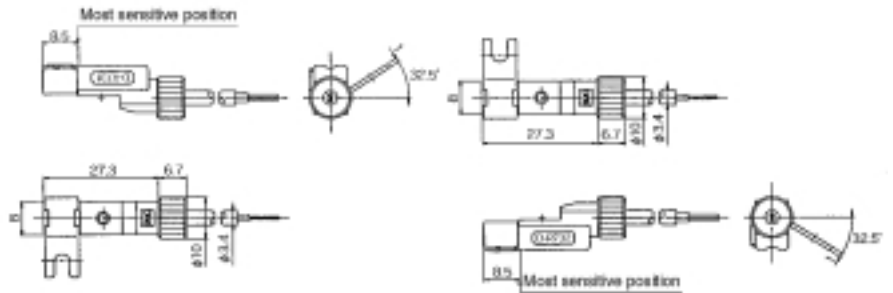

Auto switch internal circuits

Lead wire colors inside () are those prior to conformity with IEC standards.

D-R731, R732

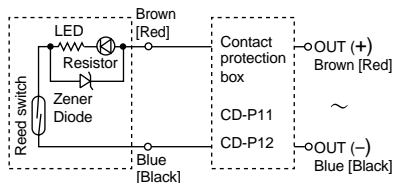

D-R801, R802

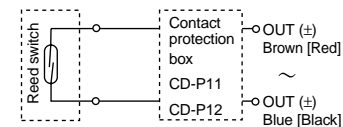

D-R801C: Right-handed

D-R802C: Left-handed

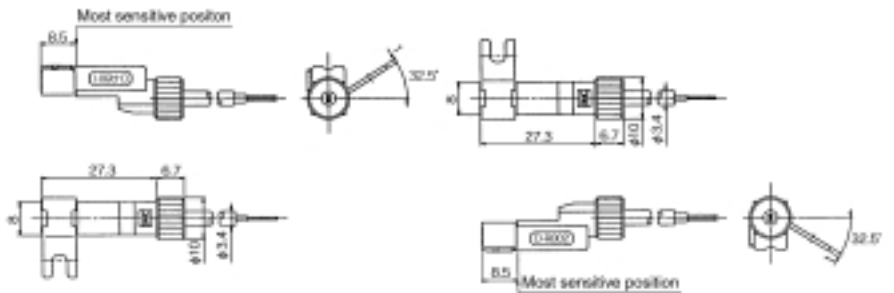

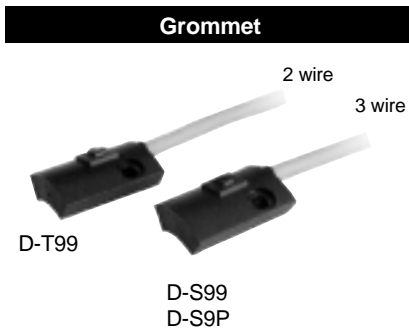

Auto Switch Specifications

D-S99 (V), D-S9P (V), D-T99 (V) (with indicator light)

Auto switch model no.	D-S991 D-S992	D-S99V1 D-S99V2	D-S9P1 D-S9P2	D-S9PV1 D-S9PV2	D-T991 D-T992	D-T99V1 D-T99V2
Electrical entry direction	In-line	Perpendicular	In-line	Perpendicular	In-line	Perpendicular
Wiring type	3 wire			2 wire		
Output type	NPN		PNP		—	
Applicable load	IC circuit, Relay, PLC			24VDC Relay, PLC		
Power supply voltage	5, 12, 24VDC (4.5 to 28VDC)			—		
Current consumption	10mA or less			—		
Load voltage	28VDC or less		—		24VDC (10 to 28VDC)	
Load current	40mA or less		80mA or less		5 to 40mA	
Internal voltage drop	1.5V or less (0.8V or less at 10mA load current)		0.8V or less		4V or less	
Leakage current	100μA or less at 24VDC			0.8mA or less at 24VDC		
Indicator light	Red LED lights up when ON					—

• Lead wires — Oil resistant, vinyl heavy duty cord, ø3.4, 0.2mm², 3 wire [Brown, Black, Blue (Red, White, Black)], 2 wire [Brown, Blue (Red, Black)], 0.5m

Note 1) Refer to page 28 for solid state switch common specifications.

Note 2) Refer to page 28 for lead wire length.

Dimensions (mm)

D-S991: Right-handed

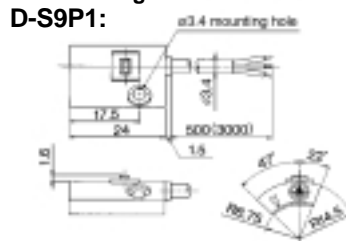

D-S992: Left-handed

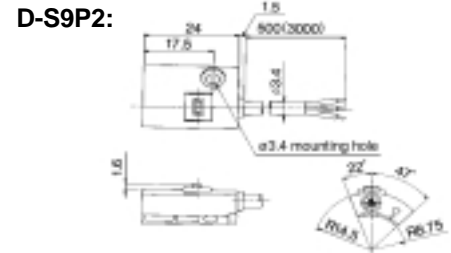

1in = 25.4mm

D-T991: Right-handed

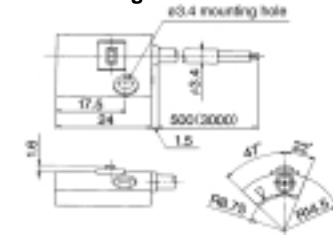

D-T992: Left-handed

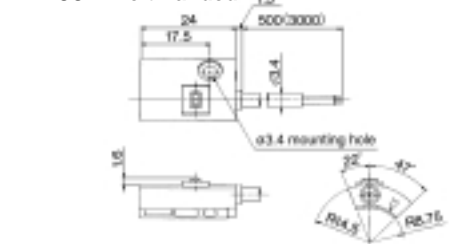

D-S99V1: Right-handed

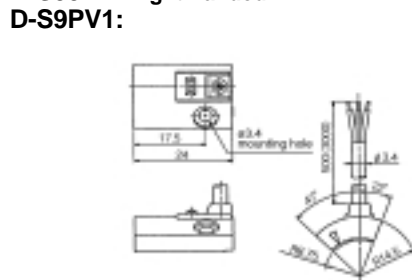

D-S99V2: Left-handed

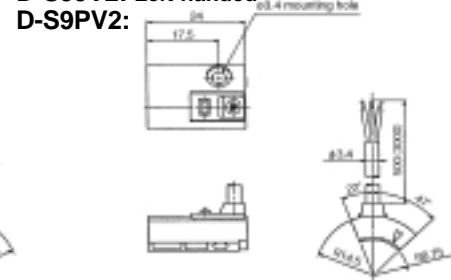

D-T99V1: Right-handed

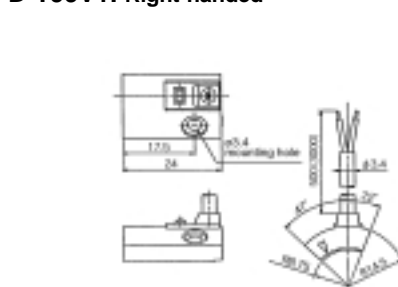

D-T99V2: Left-handed

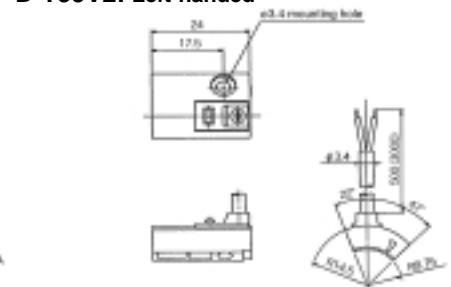

Auto switch internal circuits

Lead wire colors inside () are those prior to conformity with IEC standards.

D-S99(V)1, S99(V)2

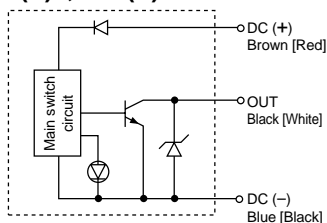

D-S9P(V)1, S9P(V)2

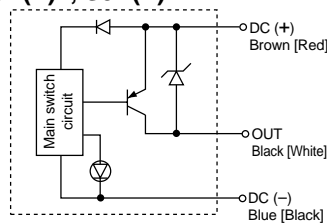

D-T99(V)1, T99(V)2

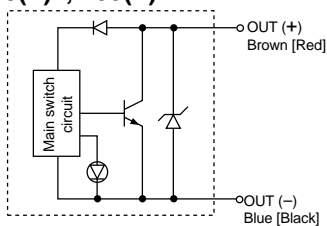

Grommet, Connector
Electrical entry direction: In-line

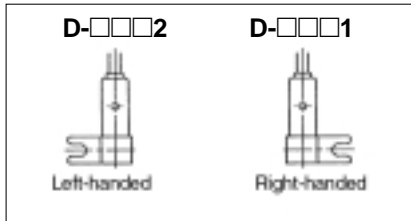
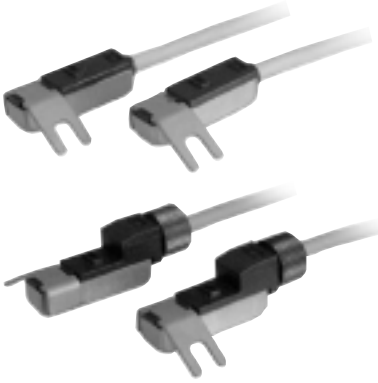

Auto switch internal circuits

Lead wire colors inside () are those prior to conformity with IEC standards.

D-S791, S792

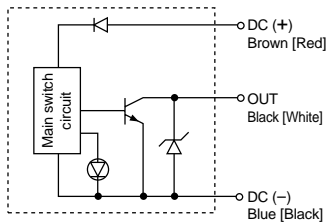

D-S7P1, S7P2

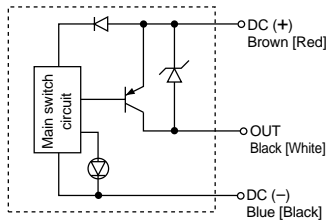

D-T791(C), T792(C)

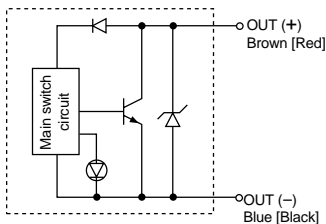

Auto Switch Specifications

D-S79, D-T79 (with indicator light)

Auto switch model no.	D-S791, D-S792	D-S7P1, D-S7P2	D-T791, D-T792, D-T791C, D-T792C
Wiring type	3 wire		2 wire
Output type	NPN	PNP	—
Applicable load	IC circuit, Relay, PLC		24VDC relay, PLC
Power supply voltage	5, 12, 24VDC (4.5 to 28VDC)		—
Current consumption	10mA or less		—
Load voltage	28VDC or less	—	24VDC (10 to 28VDC)
Load current	40mA or less	80mA or less	5 to 40mA
Internal voltage drop	1.5V or less (0.8V or less at 10mA load current)	0.8V or less	4V or less
Leakage current	100μA or less at 24VDC		0.8mA or less at 24VDC
Indicator light	Red LED lights up when ON		

• Lead wires — Oil resistant, vinyl heavy duty cord, $\phi 3.4$, 0.2mm², 3 wire [Brown, Black, Blue (Red, White, Black)], 2 wire [Brown, Blue (Red, Black)], 0.5m

Note 1) Refer to page 28 for solid state switch common specifications.

Note 2) Refer to page 28 for lead wire length.

Dimensions (mm)

D-S791: Right-handed
D-S7P1:

D-S792: Left-handed
D-S7P2:

1in = 25.4mm

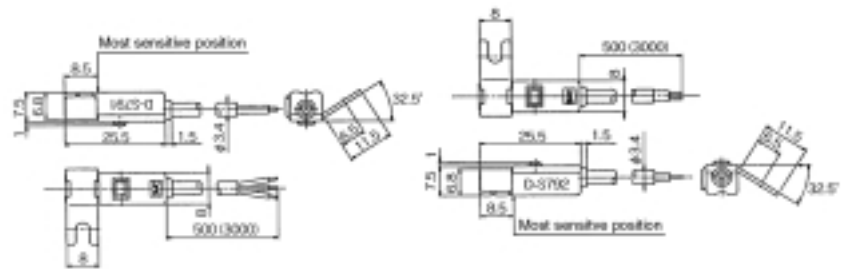

D-T791: Right-handed

D-T792: Left-handed

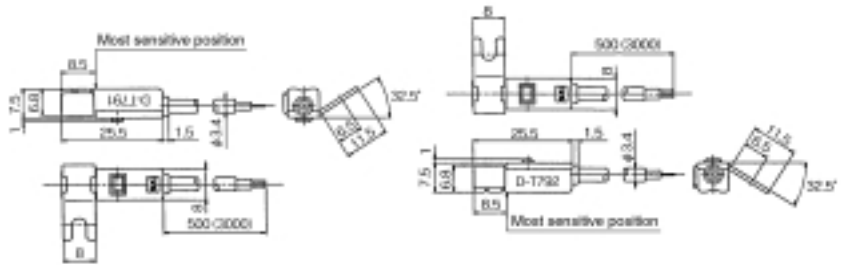

D-T791C: Right-handed

D-T792C: Left-handed

