

# DIAPHRAGM

Pumps and Compressors

## 107 Series

### MODELS:

Standard models available.

**107CAB18, 107CCD18, 107CEF18, 107CGH18**  
**107CDC20**

Other models based on availability and minimum purchase.

### FEATURES (AC& DC):

- Oil-less operation
- Permanently lubricated bearings
- Closed housing and motor vents (107CDC/C only)
- Stainless valves
- Die cast aluminum head, valve plate and diaphragm hold down plate with dichromate conversion treatment
- Balanced for smooth, low vibration operation
- Long-life diaphragm
- Field service capability
- UL® recognized motor and thermal protector (115 Volt, AC only)
- Inlet filter
- CE approval on all standard 220-240/50hz models (Consult factory for non-standard models.)

Consult factory for custom applications



107CAB, CCD



107CEF, CGH

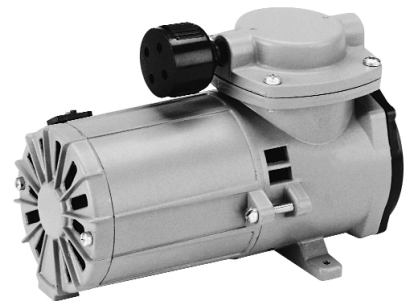

107CDC



USAThomas.com

(800) 799-4568 | 3810 Prospect Ave, Ste. A, Yorba Linda, CA 92886

# 107 SERIES (AC) PERFORMANCE DATA:

										STANDARD	
MODEL NUMBER:	107CAB050		107CAB11		107CAB14		107CAB18				
HEAD CONFIGURATION:	Pressure/Vacuum		Pressure/Vacuum		Pressure/Vacuum		Pressure/Vacuum				
STROKE:	.050 Inches		.110 Inches		.140 Inches		.180 Inches				
PRESSURE:	Flow @ 115v/110v		Flow @ 115v/110v		Flow @ 115v/110v		Flow @ 115v/110v				
CFM @ PSI	LPM @ bar										
PSI	bar		CFM	LPM	CFM	LPM	CFM	LPM	CFM	LPM	
0	0		19 / .17	5.4 / 4.8	49 / 40	13.9 / 11.3	.66 / .55	18.7 / 15.6	.69 / .58	19.5 / 16.4	
5	.5		.02 / .03		.31 / .28	7.1 / 6.4	.45 / .40	11.1 / 10.1	.60 / .49	15.8 / 12.9	
10	1.0				.18 / .16	2.3 / 2.0	.32 / .30	6.8 / 6.0	.51 / .41	11.6 / 9.9	
15	1.5				.07 / .06		.23 / .20	3.0 / 2.7	.40 / .33	8.0 / 6.4	
20	2.0						.13 / .12		.31 / .25	4.5 / 3.5	
25	3.0						.06 / .05		.23 / .18		
30									.14 / .11		
35											
MAX. CONTINUOUS PRESSURE:	5 PSI 0.3 bar		15 PSI 1.0 bar		25 PSI 1.7 bar		20 PSI 1.4 bar				
MAX. INTERMITTENT PRESSURE:	5 PSI 0.3 bar		15 PSI 1.0 bar		25 PSI 1.7 bar		30 PSI 2.1 bar				
VACUUM:	Flow @ 115v/110v		Flow @ 115v/110v		Flow @ 115v/110v		Flow @ 115v/110v				
CFM @ IN. hg	LPM @ mbar (gauge)										
IN. hg	mbar (gauge)		CFM	LPM	CFM	LPM	CFM	LPM	CFM	LPM	
0	0		19 / .17	5.4 / 4.8	49 / 40	13.9 / 11.3	.66 / .55	18.7 / 15.6	.69 / .58	19.5 / 16.4	
5	-100		3.9 / 3.3	34 / 27	11.4 / 9.2	11.4 / 9.2	.45 / .38	15.2 / 12.7	.54 / .44	17.0 / 14.1	
10	-200		2.4 / 1.8	19 / 15	8.9 / 7.0	8.9 / 7.0	.29 / .25	12.0 / 10.1	.36 / .29	14.4 / 11.7	
15	-400				3.8 / 3.0	3.8 / 3.0	.16 / .12	6.9 / 5.7	.20 / .16	8.6 / 6.9	
20	-600							2.5 / 1.4	.05 / .04	3.4 / 2.7	
25	-800										
MAX. VACUUM:	9.0" hg -305 mbar		17.2" hg -582 mbar		20.1" hg -681 mbar		22.1" hg -748 mbar				
MAX. AMBIENT TEMPERATURE:	104°F 40°C		104°F 40°C		104°F 40°C		104°F 40°C				
MIN. AMBIENT TEMPERATURE:	50°F 10°C		50°F 10°C		50°F 10°C		50°F 10°C				
MAX. RESTART PRESSURE:	0 PSI 0 bar		0 PSI 0 bar		0 PSI 0 bar		0 PSI 0 bar				
MAX. RESTART VACUUM:	0" hg 0 mbar		0" hg 0 mbar		0" hg 0 mbar		0" hg 0 mbar				
MOTOR VOLTAGE/FREQUENCY:	115/60/1-110/50/1		115/60/1-110/50/1		115/60/1-110/50/1		115/60/1-110/50/1				
HORSEPOWER:	1/20		1/20		1/20		1/20				
MOTOR TYPE:	Shaded Pole		Shaded Pole		Shaded Pole		Shaded Pole				
CURRENT AT RATED LOAD (AMPS):	1.40 / 1.60		1.45 / 1.64		1.50 / 1.74		1.69 / 2.18				
POWER AT RATED LOAD (WATTS):	80 / 85		85 / 90		92 / 100		107 / 136				
STARTING CURRENT (LOCKED ROTOR AMPS):	2.77 / 3.09		2.77 / 3.09		2.77 / 3.09		2.77 / 3.09				
INSULATION CLASS:	B		B		B		B				
MIN. FULL LOAD SPEED (RPM):	1740 / 1490		1720 / 1470		1700 / 1430		1630 / 1260				
THERMAL PROTECTOR:	Yes		Yes		Yes		Yes				
CAPACITOR VALUE:											
NET WEIGHT:	5.1 lbs. 2.3 Kg		5.1 lbs. 2.3 Kg		5.1 lbs. 2.3 Kg		5.1 lbs. 2.3 Kg				

										STANDARD	
MODEL NUMBER:	107CCD050		107CCD11		107CCD14		107CCD18				
HEAD CONFIGURATION:	Pressure/Vacuum		Pressure/Vacuum		Pressure/Vacuum		Pressure/Vacuum				
STROKE:	.050 Inches		.110 Inches		.140 Inches		.180 Inches				
PRESSURE:	Flow @ 230v/220v		Flow @ 230v/220v		Flow @ 230v/220v		Flow @ 230v/220v				
CFM @ PSI	LPM @ bar										
PSI	bar		CFM	LPM	CFM	LPM	CFM	LPM	CFM	LPM	
0	0		18 / .15	5.1 / 4.2	.38 / .32	10.8 / 9.1	.53 / .45	15.0 / 12.7	.65 / .55	18.4 / 15.6	
5	.5		10 / .08	1.8 / 1.4	.25 / .21	5.7 / 4.8	.38 / .32	9.0 / 7.5	.51 / .43	13.0 / 11.0	
10	1.0				.14 / .12	3.0 / 2.4	.24 / .20	4.5 / 3.9	.40 / .34	8.3 / 7.1	
15	1.5				.10 / .08		.15 / .13	2.3 / 1.8	.28 / .24	5.2 / 4.4	
20	2.0						.10 / .08		.20 / .17	3.1 / 2.5	
25	3.0								.15 / .13		
30									.10 / .08		
35											
MAX. CONTINUOUS PRESSURE:	5 PSI 0.3 bar		15 PSI 1.0 bar		20 PSI 1.4 bar		20 PSI 1.4 bar				
MAX. INTERMITTENT PRESSURE:	5 PSI 0.3 bar		15 PSI 1.0 bar		20 PSI 1.4 bar		30 PSI 2.1 bar				
VACUUM:	Flow @ 230v/220v		Flow @ 230v/220v		Flow @ 230v/220v		Flow @ 230v/220v				
CFM @ IN. hg	LPM @ mbar (gauge)										
IN. hg	mbar (gauge)		CFM	LPM	CFM	LPM	CFM	LPM	CFM	LPM	
0	0		18 / .15	5.1 / 4.2	.38 / .32	10.8 / 9.1	.53 / .45	15.0 / 12.7	.65 / .55	18.4 / 15.6	
5	-100		3.4 / 2.7	24 / 20	8.4 / 7.1	8.4 / 7.1	.35 / .30	12.0 / 10.2	.48 / .40	15.6 / 13.1	
10	-200		1.8 / 1.2	11 / .09	6.1 / 5.1	6.1 / 5.1	.21 / .18	9.2 / 7.9	.32 / .27	12.8 / 10.7	
15	-400				1.8 / 1.4	1.8 / 1.4	.09 / .07	4.7 / 4.0	.18 / .15	7.6 / 6.4	
20	-600									3.0 / 2.4	
25	-800										
MAX. VACUUM:	9.0" hg -305 mbar		16.9" hg -572 mbar		19.0" hg -643 mbar		22.0" hg -746 mbar				
MAX. AMBIENT TEMPERATURE:	104°F 40°C		104°F 40°C		104°F 40°C		104°F 40°C				
MIN. AMBIENT TEMPERATURE:	50°F 10°C		50°F 10°C		50°F 10°C		50°F 10°C				
MAX. RESTART PRESSURE:	0 PSI 0 bar		0 PSI 0 bar		0 PSI 0 bar		0 PSI 0 bar				
MAX. RESTART VACUUM:	0" hg 0 mbar		0" hg 0 mbar		0" hg 0 mbar		0" hg 0 mbar				
MOTOR VOLTAGE/FREQUENCY:	230/60/1-220/50/1		230/60/1-220/50/1		230/60/1-220/50/1		230/60/1-220/50/1				
HORSEPOWER:	1/20		1/20		1/20		1/20				
MOTOR TYPE:	Shaded Pole		Shaded Pole		Shaded Pole		Shaded Pole				
CURRENT AT RATED LOAD (AMPS):	.6 / .8		.7 / .9		.7 / .9		.8 / 1.0				
POWER AT RATED LOAD (WATTS):	75 / 85		80 / 100		90 / 100		100 / 120				
STARTING CURRENT (LOCKED ROTOR AMPS):	1.2		1.2		1.2		1.2				
INSULATION CLASS:	B		B		B		B				
MIN. FULL LOAD SPEED (RPM):	1750 / 1450		1730 / 1430		1700 / 1390		1620 / 1220				
THERMAL PROTECTOR:	Yes		Yes		Yes		Yes				
CAPACITOR VALUE:											
NET WEIGHT:	5.1 lbs. 2.3 Kg		5.1 lbs. 2.3 Kg		5.1 lbs. 2.3 Kg		5.1 lbs. 2.3 Kg				

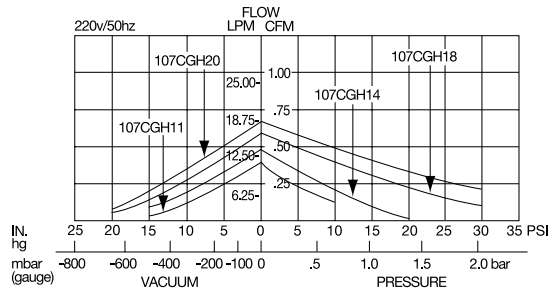
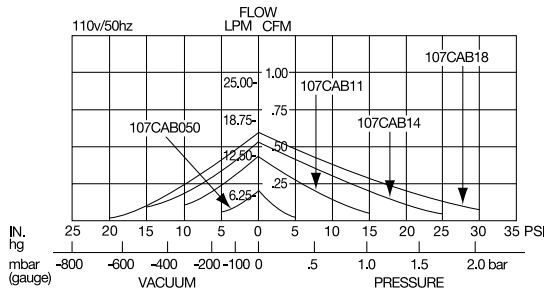
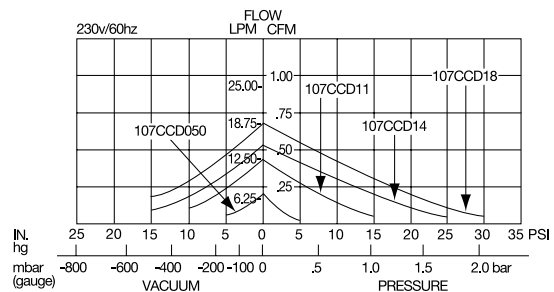
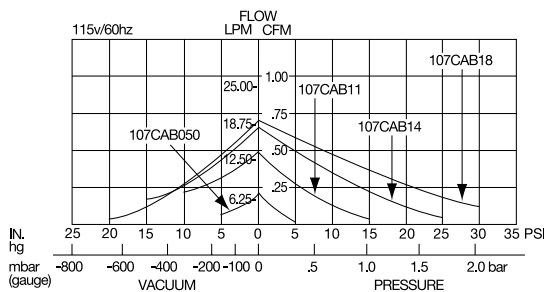

# 107 SERIES (AC) PERFORMANCE DATA:

MODEL NUMBER:	STANDARD							
	107CEF11		107CEF14		107CEF18		107CEF20	
HEAD CONFIGURATION:	Pressure/Vacuum		Pressure/Vacuum		Pressure/Vacuum		Pressure/Vacuum	
STROKE:	.110 Inches		.140 Inches		.180 Inches		.200 Inches	
PRESSURE:	Flow @ 115v/110v		Flow @ 115v/110v		Flow @ 115v/110v		Flow @ 115v/110v	
CFM @ PSI	LPM @ bar							
PSI	bar		CFM	LPM	CFM	LPM	CFM	LPM
0	0		51 / 43	14.4 / 12.2	65 / 56	18.4 / 15.9	73 / 60	20.7 / 17.0
5	.5		29 / 25	6.3 / 5.3	43 / 37	10.4 / 8.8	66 / 53	17.3 / 13.9
10	1.0		.14 / .11		29 / 24	5.2 / 4.0	55 / 44	13.0 / 10.4
15	1.5				17 / 13		45 / 36	9.1 / 7.5
20	2.0				.05 / .03		35 / 29	5.6 / 4.2
25	3.0						27 / 22	
30							.18 / .13	
35								
MAX. CONTINUOUS PRESSURE:	10 PSI	0.7 bar	20 PSI	1.4 bar	30 PSI	2.1 bar	10 PSI	0.7 bar
MAX. INTERMITTENT PRESSURE:	10 PSI	0.7 bar	20 PSI	1.4 bar	30 PSI	2.1 bar	10 PSI	0.7 bar
VACUUM:	Flow @ 115v/110v		Flow @ 115v/110v		Flow @ 115v/110v		Flow @ 115v/110v	
CFM @ IN. hg	LPM @ mbar (gauge)							
IN. hg	mbar (gauge)		CFM	LPM	CFM	LPM	CFM	LPM
0	0		51 / 43	14.4 / 12.2	65 / 56	18.4 / 15.9	73 / 60	20.7 / 17.0
5	-100		34 / 28	11.6 / 10.0	43 / 38	14.7 / 12.8	55 / 46	17.7 / 14.6
10	-200		.19 / .15	8.9 / 7.3	27 / 24	11.4 / 10.0	38 / 31	14.7 / 12.3
15	-400		.05 / .03	4.0 / 3.0	.15 / .14	6.4 / 5.8	23 / 17	9.2 / 7.3
20	-600				2.4 / 2.4		0.7 / 0.5	4.0 / 3.0
25	-800							
MAX. VACUUM:	16.7" hg	-565 mbar	19.5" hg	-660 mbar	22.7" hg	-769 mbar	23.2" hg	-786 mbar
MAX. AMBIENT TEMPERATURE:	104°F	40°C	104°F	40°C	104°F	40°C	104°F	40°C
MIN. AMBIENT TEMPERATURE:	50°F	10°C	50°F	10°C	50°F	10°C	50°F	10°C
MAX. RESTART PRESSURE:	0 PSI	0 bar	0 PSI	0 bar	0 PSI	0 bar	0 PSI	0 bar
MAX. RESTART VACUUM:	0" hg	0 mbar	0" hg	0 mbar	0" hg	0 mbar	0" hg	0 mbar
MOTOR VOLTAGE/FREQUENCY:	115/60/1-110/50/1		115/60/1-110/50/1		115/60/1-110/50/1		115/60/1-110/50/1	
HORSEPOWER:	1/20		1/20		1/20		1/20	
MOTOR TYPE:	Permanent Split Capacitor		Permanent Split Capacitor		Permanent Split Capacitor		Permanent Split Capacitor	
CURRENT AT RATED LOAD (AMPS):	.86 / 1.15		.93 / 1.22		1.05 / 1.48		1.14 / 1.55	
POWER AT RATED LOAD (WATTS):	70 / 79		77 / 93		90 / 118		99 / 126	
STARTING CURRENT (LOCKED ROTOR AMPS):	2.07 / 2.17		2.07 / 2.17		2.07 / 2.17		2.07 / 2.17	
INSULATION CLASS:	B		B		B		B	
MIN. FULL LOAD SPEED (RPM):	1755 / 1505		1535 / 1480		1720 / 1330		1675 / 1400	
THERMAL PROTECTOR:	Yes		Yes		Yes		Yes	
CAPACITOR VALUE:	5 mfd		5 mfd		5 mfd		5 mfd	
NET WEIGHT:	6 lbs.	2.7 Kg	6 lbs.	2.7 Kg	6 lbs.	2.7 Kg	6 lbs.	2.7 Kg

MODEL NUMBER:	STANDARD							
	107CGH11		107CGH14		107CGH18		107CGH20	
HEAD CONFIGURATION:	Pressure/Vacuum		Pressure/Vacuum		Pressure/Vacuum		Pressure/Vacuum	
STROKE:	.110 Inches		.140 Inches		.180 Inches		.200 Inches	
PRESSURE:	Flow @ 230v/220v		Flow @ 230v/220v		Flow @ 230v/220v		Flow @ 230v/220v	
CFM @ PSI	LPM @ bar							
PSI	bar		CFM	LPM	CFM	LPM	CFM	LPM
0	0		44 / 38	12.5 / 10.8	57 / 48	16.1 / 13.6	69 / 59	20.0 / 16.7
5	.5		34 / 27	7.6 / 6.0	47 / 38	11.5 / 9.6	63 / 52	16.3 / 13.7
10	1.0		.18 / .14		33 / 29	6.3 / 5.7	51 / 44	12.4 / 10.4
15	1.5				21 / 19	2.0 / 1.8	43 / 36	8.8 / 7.4
20	2.0				.10 / .09		35 / 29	5.0 / 4.1
25	3.0				.02 / .01		24 / 21	
30							.16 / .13	
35								
MAX. CONTINUOUS PRESSURE:	10 PSI	.7 bar	20 PSI	1.4 bar	20 PSI	1.4 bar	20 PSI	1.4 bar
MAX. INTERMITTENT PRESSURE:	10 PSI	.7 bar	25 PSI	1.7 bar	30 PSI	2.1 bar	30 PSI	2.1 bar
VACUUM:	Flow @ 230v/220v		Flow @ 230v/220v		Flow @ 230v/220v		Flow @ 230v/220v	
CFM @ IN. hg	LPM @ mbar (gauge)							
IN. hg	mbar (gauge)		CFM	LPM	CFM	LPM	CFM	LPM
0	0		44 / 38	12.5 / 10.8	57 / 48	16.1 / 13.6	69 / 59	20.0 / 16.7
5	-100		32 / 26	10.5 / 8.8	43 / 34	13.8 / 11.3	55 / 46	17.2 / 15.0
10	-200		.19 / .14	8.4 / 6.7	27 / 21	11.4 / 9.0	38 / 31	14.7 / 12.3
15	-400		.05 / .03	4.0 / 2.8	.12 / .10	6.1 / 4.8	22 / 17	9.1 / 7.3
20	-600				1.1 / 1.1		0.7 / 0.5	4.0 / 3.0
25	-800							
MAX. VACUUM:	17.5" hg	-593 mbar	19.9" hg	-674 mbar	22.5" hg	-762 mbar	23.8" hg	-806 mbar
MAX. AMBIENT TEMPERATURE:	104°F	40°C	104°F	40°C	104°F	40°C	104°F	40°C
MIN. AMBIENT TEMPERATURE:	50°F	10°C	50°F	10°C	50°F	10°C	50°F	10°C
MAX. RESTART PRESSURE:	0 PSI	0 bar	0 PSI	0 bar	0 PSI	0 bar	0 PSI	0 bar
MAX. RESTART VACUUM:	0" hg	0 mbar	0" hg	0 mbar	0" hg	0 mbar	0" hg	0 mbar
MOTOR VOLTAGE/FREQUENCY:	230/60/1-220/50/1		230/60/1-220/50/1		230/60/1-220/50/1		230/60/1-220/50/1	
HORSEPOWER:	1/20		1/20		1/20		1/20	
MOTOR TYPE:	Permanent Split Capacitor		Permanent Split Capacitor		Permanent Split Capacitor		Permanent Split Capacitor	
CURRENT AT RATED LOAD (AMPS):	.49 / .43		.53 / .51		.60 / .62		.65 / .65	
POWER AT RATED LOAD (WATTS):	93 / 84		102 / 99		119 / 125		132 / 133	
STARTING CURRENT (LOCKED ROTOR AMPS):	.83 / .93		.83 / .93		.83 / .93		.83 / .93	
INSULATION CLASS:	B		B		B		B	
MIN. FULL LOAD SPEED (RPM):	1760 / 1460		1750 / 1450		1695 / 1340		1620 / 1210	
THERMAL PROTECTOR:	Yes		Yes		Yes		Yes	
CAPACITOR VALUE:	5 mfd		5 mfd		5 mfd		5 mfd	
NET WEIGHT:	6 lbs.	2.7 Kg	6 lbs.	2.7 Kg	6 lbs.	2.7 Kg	6 lbs.	2.7 Kg

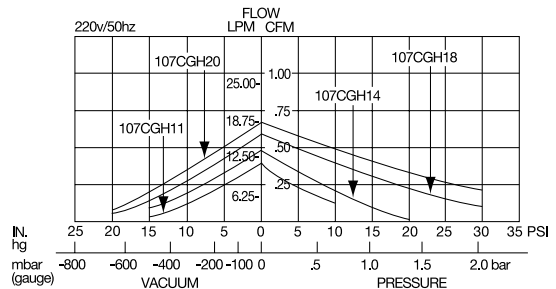
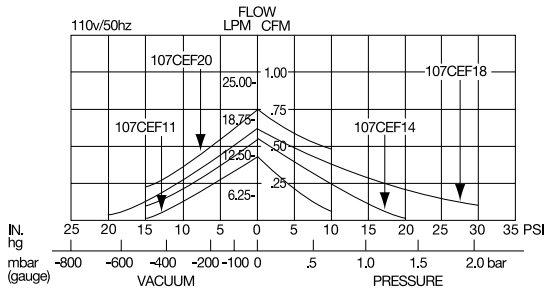
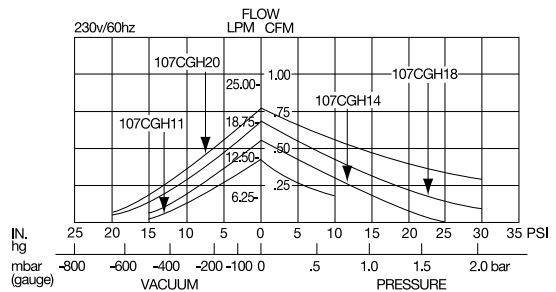
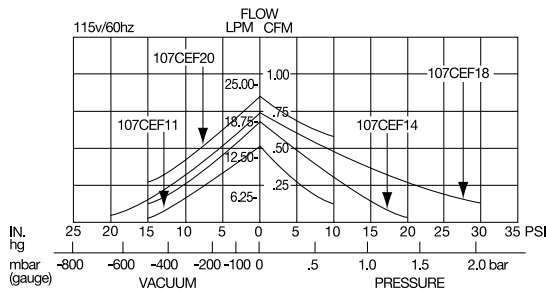

# 107 SERIES (DC) PERFORMANCE DATA:

		STANDARD			
MODEL NUMBER:		107CDC20		107CDC/C20	
HEAD CONFIGURATION:		Pressure/Vacuum		Pressure/Vacuum	
STROKE:		.200 Inches		.200 Inches	
PRESSURE:		Flow @ 12v		Flow @ 12v	
CFM @ PSI	LPM @ bar	CFM	LPM	CFM	LPM
PSI	bar	CFM	LPM	CFM	LPM
0	0	1.40	39.6	1.40	39.6
5	.5	1.34	35.1	1.34	35.1
10	1.0	1.12	27.1	1.12	27.1
15	1.5	.94	20.2	.94	20.1
20	2.0	.77	14.5	.77	
25	3.0	.61	6.2		
30		.49			
35		.39			
MAX. CONTINUOUS PRESSURE:		35 PSI	2.4 bar	20 PSI	1.4 bar
MAX. INTERMITTENT PRESSURE:		35 PSI	2.4 bar	20 PSI	1.4 bar
VACUUM:		Flow @ 12v		Flow @ 12v	
CFM @ IN. hg	LPM @ mbar (gauge)	CFM	LPM	CFM	LPM
IN. hg	mbar (gauge)	CFM	LPM	CFM	LPM
0	0	1.40	39.6	1.40	39.6
5	-100	1.09	34.4	1.09	34.4
10	-200	.80	29.3	.80	29.3
15	-400	.48	19.3	.48	19.3
20	-600		8.6		8.6
25					
MAX. VACUUM:		22.9" hg	-775 mbar	22.9" hg	-775 mbar
MAX. AMBIENT TEMPERATURE:		104°F	40°C	104°F	40°C
MIN. AMBIENT TEMPERATURE:		50°F	10°C	50°F	10°C
MAX. RESTART PRESSURE:		15 PSI	1.0 bar	15 PSI	1.0 bar
MAX. RESTART VACUUM:		22.9" hg	-775 mbar	22.9" hg	-775 mbar
MOTOR VOLTAGE/FREQUENCY:		12v DC		12v DC	
HORSEPOWER:		1/10		1/10	
MOTOR TYPE:		Permanent Magnet		Permanent Magnet	
CURRENT AT RATED LOAD (AMPS):		8.5		8.5	
POWER AT RATED LOAD (WATTS):					
STARTING CURRENT (LOCKED ROTOR AMPS):		40.0		40.0	
INSULATION CLASS:		A		A	
MIN. FULL LOAD SPEED (RPM):		2970		2970	
THERMAL PROTECTOR:		No		No	
CAPACITOR VALUE:					
NET WEIGHT:		4.5 lbs.	2.0 Kg	4.7 lbs.	2.1 Kg

## DIMENSIONS:

Millimeters are in ( )

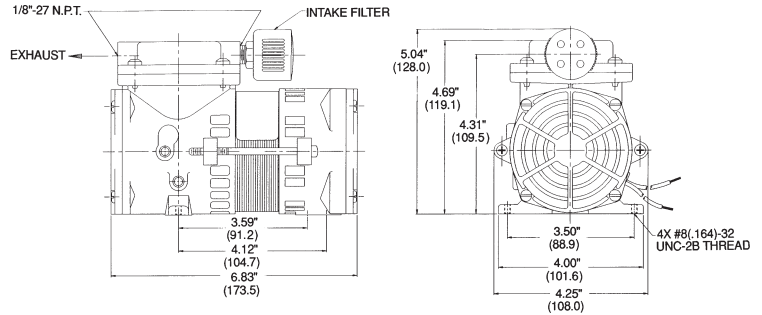

107CAB, CCD

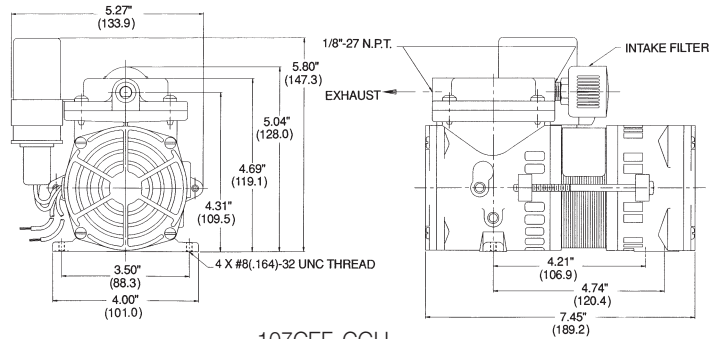

107CEF, CGH

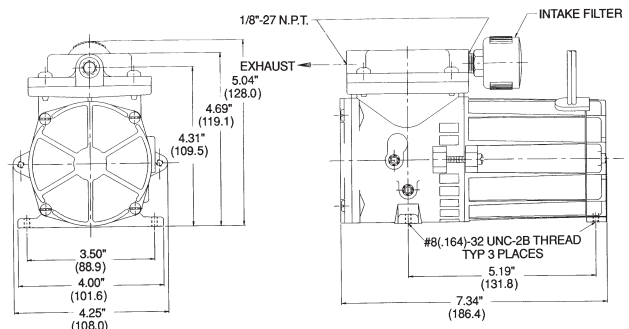

107CDC & 107CDC/C

NOTE: 107CDC/C has closed motor vents

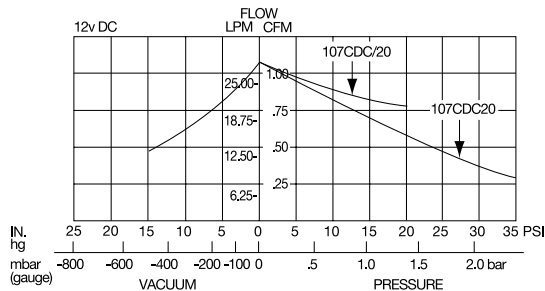

The information presented in this material is based on technical data and test results of nominal units. It is believed to be accurate and reliable and is offered as an aid to help in the selection of Thomas products. It is the responsibility of the user to determine the suitability of the product for his intended use and the user assumes all risk and liability whatsoever in connection therewith. Thomas Industries does not warrant, guarantee or assume any obligation or liability in connection with this information.

**Note:** Models pictured are representative of the series and do not represent a specific model number. Consult factory for detailed physical description.



Printed in U.S.A. Form No. 850-2274 9/01  
©2001 Thomas Industries, Inc. All rights reserved.