



2688T SERIES

MODELS

2688TE44/38
2688TGH144/38



FEATURES

- Head design allows easily replaced piston seal
- Oil-less, non-lube piston and cylinder
- Permanently lubricated bearings
- Stainless steel valves
- Lightweight die cast aluminum components
- Long-life, high performance piston seal
- Thin wall, hard-coated aluminum cylinder for maximum heat transfer
- Twin fans provide cooling air through and around motor and cylinders
- Dual intake/exhaust manifold system for easy piping
- Balanced for smooth, low vibration operation
- Field service capability
- Inlet filter
- Capacitor
- All wetted aluminum parts treated for corrosion protection from moisture
- Patented one piece head for fewer parts and reduced leak paths
- UL Recognized motor and thermal protector, 115v/60Hz models
- TUV approved 220-240/50Hz model

Declaration documentation for applicable models available upon request

Consult factory for custom applications

Thomas Division is an ISO 9001 registered company

THOMAS
A Gardner Denver Product

USAThomas.com

(800) 799-4568 | 3810 Prospect Ave, Ste. A, Yorba Linda, CA 92886

2688T Series Performance Data

MODEL NUMBER		2688TE44/38		2688TGH144/38	
HEAD CONFIGURATION		Pressure Only		Pressure Only	
STROKE		.440 Primary / .380 Secondary		.440 Primary / .380 Secondary	
PRESSURE		Flow @ 115V		Flow @ 220V 50Hz	
CFM @ PSI	LPM @ bar				
PSI	bar	CFM	LPM	CFM	LPM
0	0	1.52	43.0	1.22/1.52	34.5/43.0
20	.5	1.41	43.6	1.14/1.41	33.9/43.6
40	1.0	1.35	42.4	1.11/1.35	33.0/42.4
60	1.5	1.32	39.3	1.09/1.32	31.9/39.3
80	2.0	1.30	38.4	1.07/1.30	31.3/38.4
100	3.0	1.28	37.9	1.06/1.28	30.8/37.9
120	5.0	1.25	37.1	1.04/1.25	30.1/37.1
140	7.0	1.24	35.9	1.03/1.24	29.6/35.9
160		1.21		1.01/1.21	
MAX. CONTINUOUS PRESSURE		160 PSI	11.1 bar	160 PSI	11.1 bar
MAX. INTERMITTENT PRESSURE		160 PSI	11.1 bar	160 PSI	11.1 bar
MAX. AMBIENT AIR TEMP.		104° F	40°C	104° F	40°C
MIN. AMBIENT START TEMP.		50° F	10°C	50° F	10°C
MAX. RESTART PRESSURE		0 PSI	0 bar	0 PSI	0 bar
MOTOR VOLTAGE/FREQUENCY		115/60/1		220-240/50/1 - 230/60/1	
MOTOR TYPE		Permanent Split Capacitor		Permanent Split Capacitor	
CURRENT AT RATED LOAD (AMPS)		4.7		2.6/2.0	
POWER AT RATED LOAD (WATTS)		465		480/440	
STARTING CURRENT (LOCKED ROTOR, AMPS)		12.7		6.8/6.0	
CAPACITOR VALUE					
MIN. FULL LOAD SPEED (RPM)		1730		1440/1735	
THERMAL PROTECTOR		Yes		Yes	
NET WEIGHT		16 lbs.	7.3 kg	15 lbs.	6.8 kg

2688T

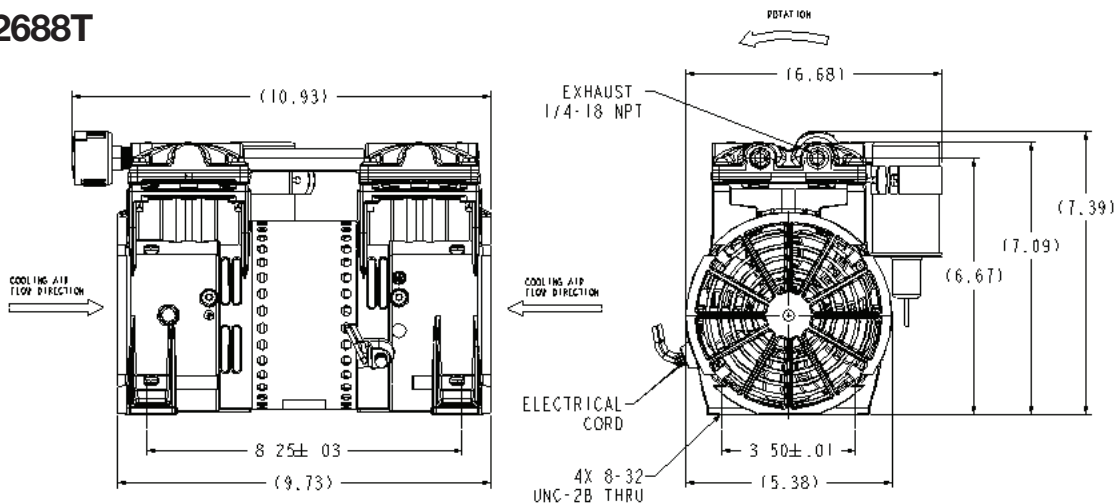

The information presented in this material is based on technical data and test results of nominal units. It is believed to be accurate and reliable and is offered as an aid to help in the selection of Thomas products. It is the responsibility of the user to determine the suitability of the product for his intended use and the user assumes all risk and liability whatsoever in connection therewith. Thomas Industries does not warrant, guarantee or assume any obligation or liability in connection with this information.

NOTE: Models pictured are representative of the series and do not represent a specific model number. Consult factory for detailed physical description.

THOMAS
A Gardner Denver Product