

5-Port Solenoid Valve

Plug-in Type



Due to the flow increase,
the valve size can be reduced!

Saves **energy** and **space**

SY3000

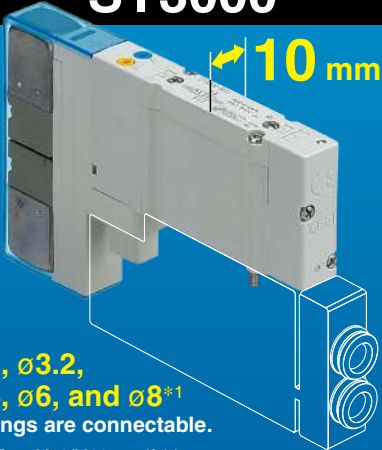

10 mm

ø2, ø3.2, ø4, ø6, and ø8*1 fittings are connectable.

*1 Type M10/M11 manifold

SY5000

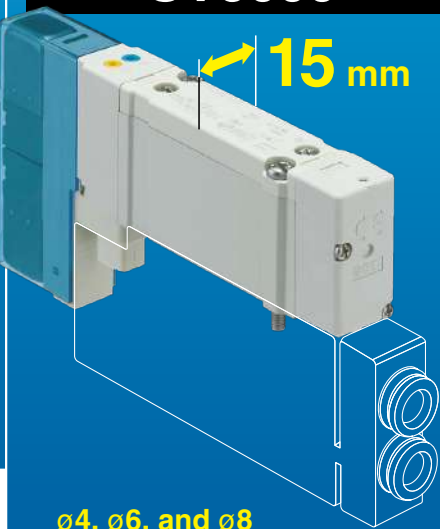

15 mm

ø4, ø6, and ø8 fittings are connectable.

SY7000

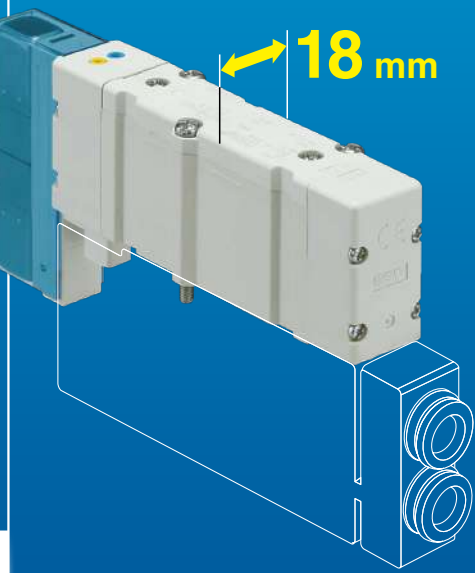

18 mm

ø6, ø8, ø10, and ø12 fittings are connectable.

At 300 mm/s

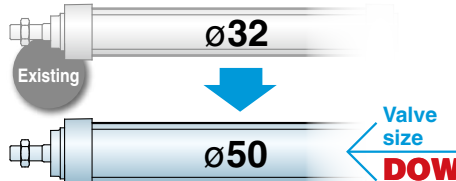

Existing ø32

Valve size DOWN

ø50

Can drive cylinders of up to **ø50***2 (ø80 at 100 mm/s)

At 300 mm/s

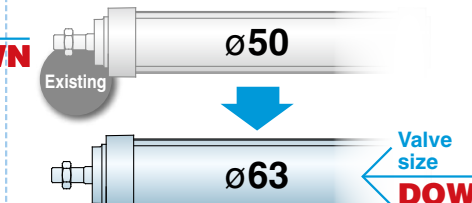

Existing ø50

Valve size DOWN

ø63

Can drive cylinders of up to **ø63***2 (ø125 at 100 mm/s)

At 300 mm/s

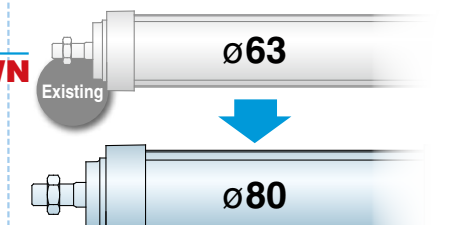

Existing ø63

Valve size DOWN

ø80

Can drive cylinders of up to **ø80***2 (ø160 at 100 mm/s)

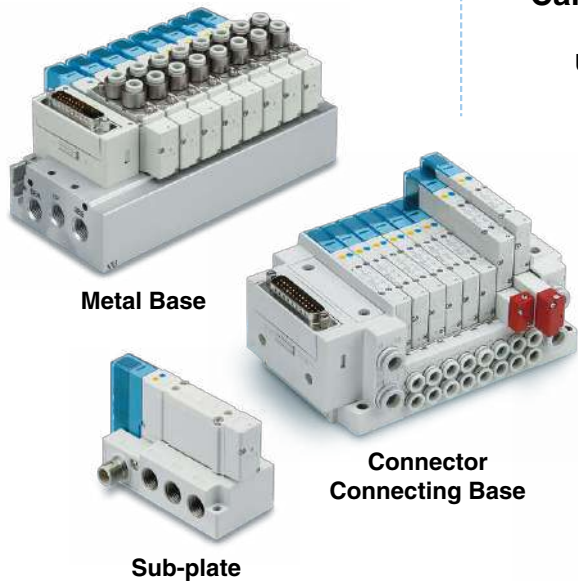

*2 Values based on comparison with the existing SMC model
For details, refer to page 13.

Compatible with wireless systems

With pressure sensor



SY3000/5000/7000 Series



CAT.ES11-103E

5-Port Solenoid Valve

Plug-in Connector Connecting Base [IP67*1]

*1 Refer to page 37 for details on IP67.

Manifold

Side ported [From p. 41](#)

Bottom ported [From p. 41](#)

Top ported [From p. 53](#)

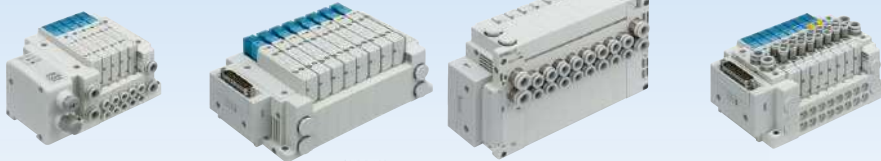

Plug-in Compatible sub-plate type

[From p. 280](#)



Connector type manifold

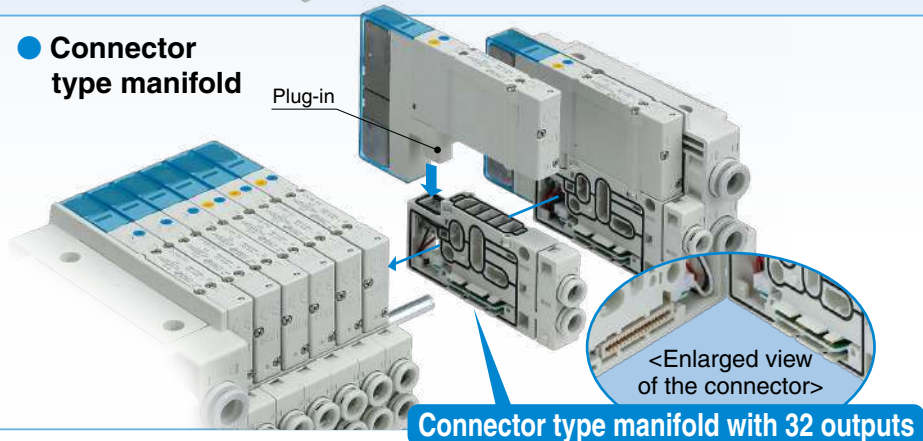

- IP67 enclosure for standard specifications
- The M12 waterproof connector type ensures easy attaching/detaching and wiring.
- Applicable to the side, top, and bottom-porting types (4A and 2B ports)

Plug-in Metal Base [IP40]

Side ported [From p. 223](#)

Bottom ported [From p. 223](#)

Top ported [From p. 243](#)



Wiring

- D-sub Connector
- Flat Ribbon Cable
- Terminal Block Box
- Lead Wire
- Circular Connector
- Serial Transmission

Serial Transmission Variations

Series	Gateway-type		Integrated-type (for input/output)			Integrated-type (for output)			
	EX510	EX500	EX600	EX245	EX250	EX260	EX126	EX120	EX180
Applicable protocol									
DeviceNet™	●	●	●		●	●		●	●
PROFIBUS DP	●	●	●		●	●		●	●
CC-Link	●		●		●	●	●	●	●
EtherNet/IP™		●	●		●	●	●	●	●
EtherCAT			●		●	●			
PROFINET		●	●	●		●			
CANopen					●				
AS-Interface					●				
OMRON CompoBus/S								●	
CompoNet™								●	
Ethernet POWERLINK						●			
IO-Link						●			
EtherNet/IP™ compatible wireless base			●						
PROFINET compatible wireless base			●						
PROFIsafe						●			

Power Saving

Power Consumption

[Electrical power waveform with power saving circuit]

With power saving circuit **0.1 w**
Standard **0.35 w**

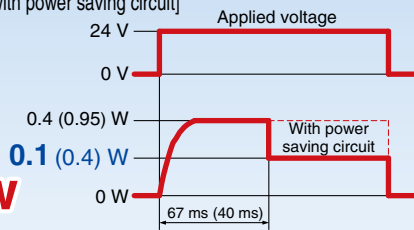

Power consumption is reduced by the power saving circuit.

Power consumption is decreased to approx. 1/3 by reducing the wattage required to hold the valve in an energized state. (Effective energizing time is over 67 ms at 24 VDC.) Refer to the electrical power waveform to the left.

- * Only products with an indicator light are equipped with the power saving circuit.
- * The value in () is for the quick response and high pressure types.

Long Service Life

Metal seal

(Service life: **200 million cycles**)*1

- *1 According to SMC life test conditions
- *2 Please contact SMC if life test data is required.

Space Saving / Improved Operability

Wiring, piping, and operation are integrated on one side.

A multiple-layer type is available as an option that saves space in the lateral direction. **From p. 204**

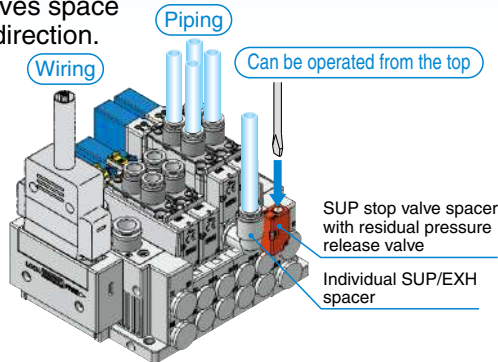

A 4-position dual 3-port valve is available.

(Only for the rubber seal type)

• Two 3-port valves built into one body

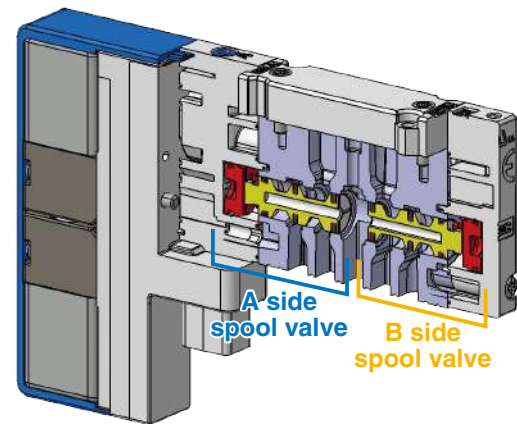

- 3-port valves on the A and B sides can be operated independently.
- When used as a 3-port valve, only half the number of stations is required.
- Can also be used as a 4-position, 5-port valve
- A 4-position dual 3-port valve with a back pressure check valve is also available.
- Combination examples

Series	A side	B side
SY□A ₃ 0	N.C. valve	N.C. valve
SY□B ₃ 0	N.O. valve	N.O. valve
SY□C ₃ 0	N.C. valve	N.O. valve

A bottom-ported type is available (A and B ports). Space saving

By using the bottom-ported type, it is possible to reduce the amount of space required for installation.

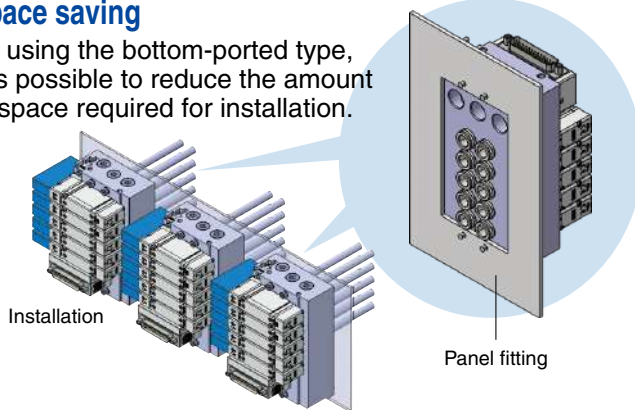

Different sizes (SY3000/5000 or SY5000/7000) can be mixed! **From p. 165**

It is possible to reduce installation space, the number of serial units, and the amount of wiring.

Overall manifold length
Approx. 29% reduction

For serial transmission EX260

Installation space

SY5000 manifold
SY5000: 3 stations

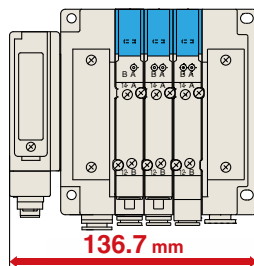

SY3000 manifold
SY3000: 4 stations

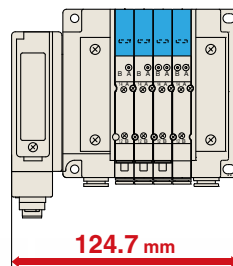

Mixed manifold

SY5000: 3 stations, SY3000: 4 stations

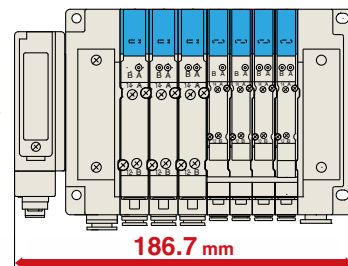

Number of serial units



5-Port Solenoid Valve

Improved Safety

Back Pressure Check Valve

This prevents actuator and air operated valve malfunctions caused by the exhaust from other valves.*1

Built-in valve type

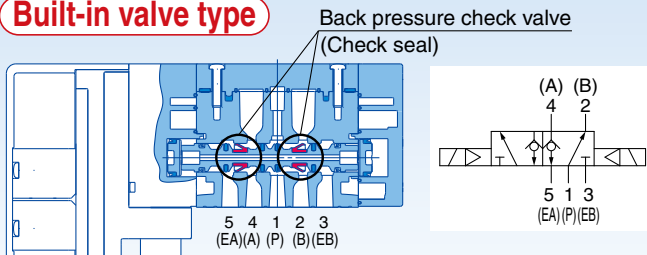

*1 For back pressure check valve precautions, refer to the "Specific Product Precautions" on page 291.

Retrofit or pre-installed type

If the product is affected by back pressure after installation, a back pressure check valve assembly can be added.

p. 212

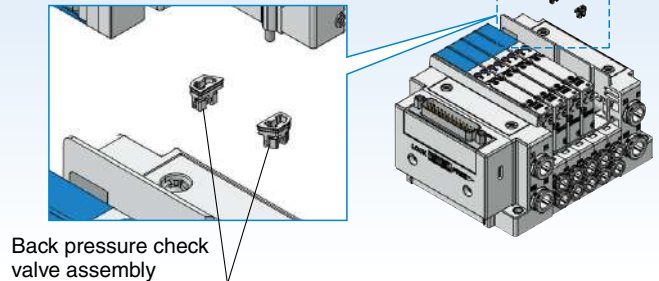

With residual pressure release valve (SY5000/7000) p. 24

For residual pressure release of the 3-position closed center valve

- The pressure of the 4 (A) and 2 (B) ports is exhausted automatically when the pressure of the 1 (P) port is exhausted.
- The pressure can be visualized using the indicator (red).
- Since this valve is not a spacer type, the flow rate is equivalent to that of the normal closed center valve.

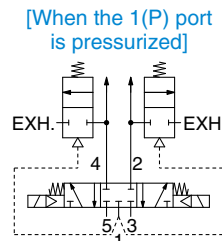
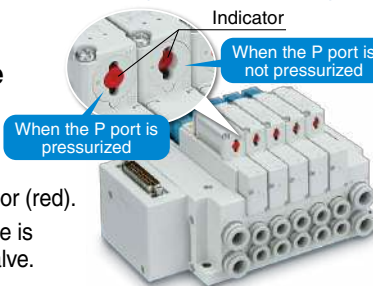

IP67 compliant

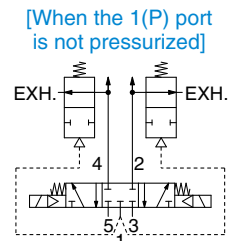

Lever Type SUP Stop Valve Spacer (With residual pressure release valve) p. 205

A lever has been added to manual override button!

Solenoid valves can be replaced individually without shutting off the main pressure!*

2-action operation

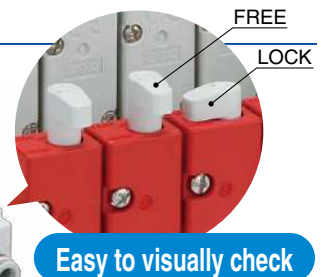
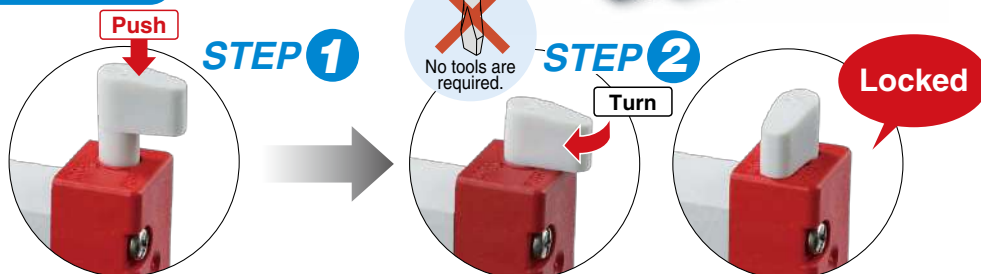

Air for solenoid valves can be shut off individually!

The operation of an actuator can be checked by individually shutting off the air for the solenoid valves on the base while the main air is being supplied during a trial operation.

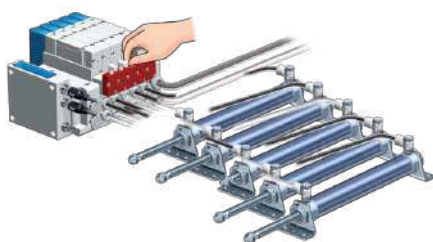

Solenoid valves can be replaced individually!

The solenoid valves can be replaced individually without stopping the equipment during maintenance.

<Application example>
For air operated valves, such as sanitary valves, and automatic valve control

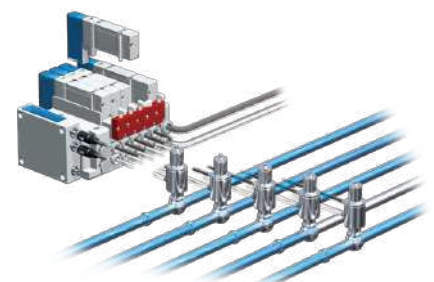

*1 This product is only for internal pilot specifications as the external pilot air cannot be shut off.

Improved Safety

Slotted Type

SUP Stop Valve Spacer

(With residual pressure release valve) p. 205

Air supply to each valve can be stopped individually. The valve and cylinder can be replaced without stopping other devices and equipment.

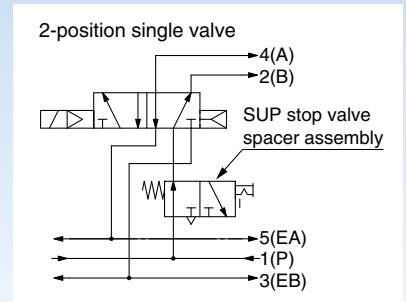
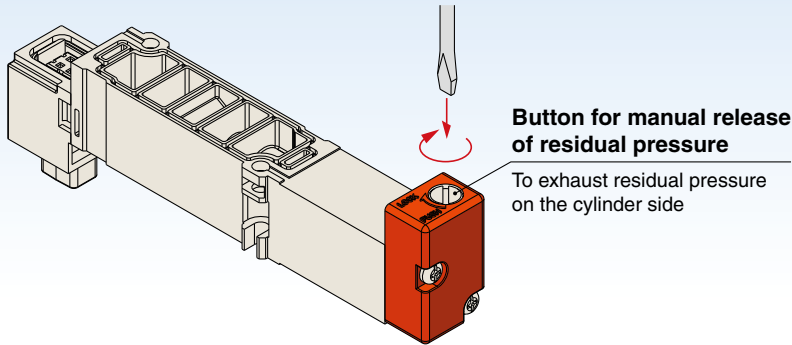

2-position single valve example

Slotted Type

Double Check Spacer

(With residual pressure release valve) p. 206

Long intermediate stops and position holding are possible.

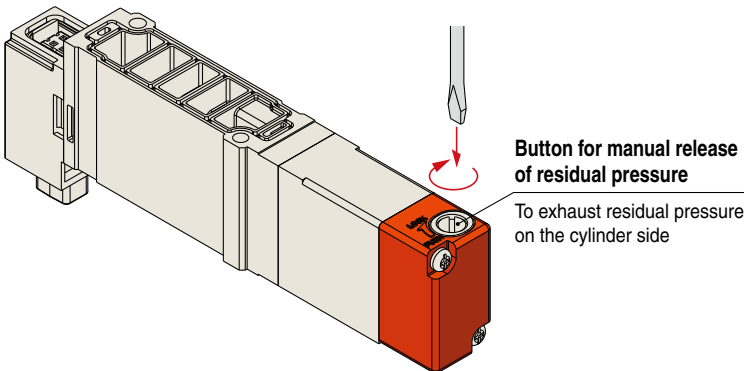

[Intermediate stop]

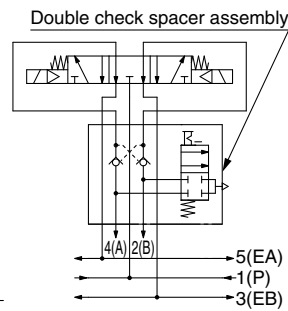

Exhaust center

[Drop prevention]

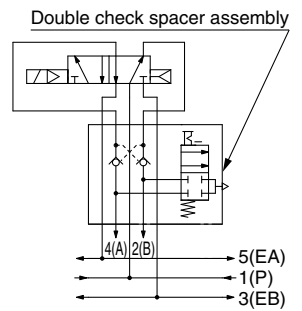

2-position single/double

With slide locking manual override

ON/OFF operation and locking can be performed manually.

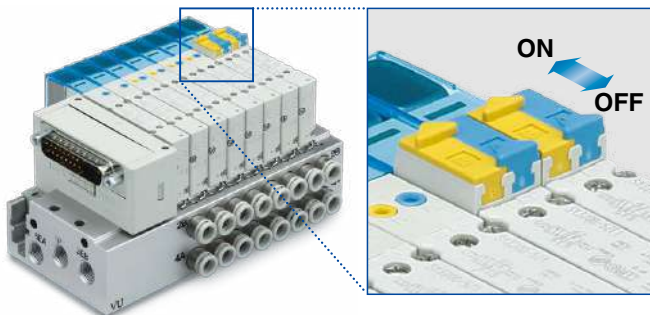

The ON/OFF state can be checked at a glance.

Yellow B side Blue A side

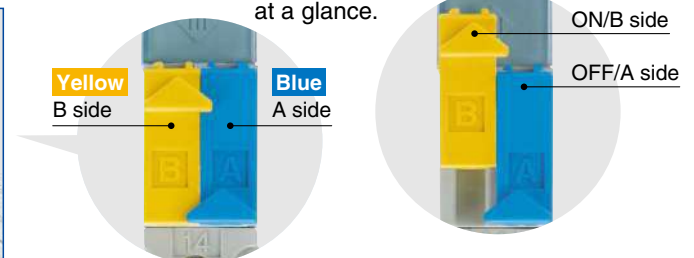

5-Port Solenoid Valve

Improved Safety

Made to Order

With safety slide locking manual override
SY3000/5000/7000-X13 p. 34

The double action manual override prevents accidental operation!

SY7000-X13

SY5000-X13

SY3000-X13



● Double-action operation

Before operation The slide locking manual overrides cannot be turned ON with the safety slide cover in place. (OFF status: Locked)

Operation 1 The safety slide cover is operated and moves upward. (Unlocked)

Operation 2 The slide locking manual overrides can be operated.

Safety slide cover Slide locking manual overrides

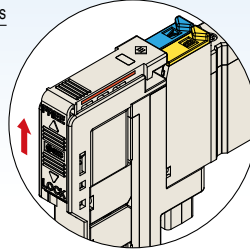
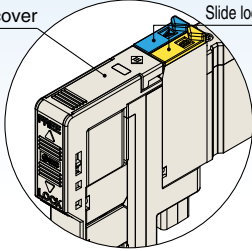

<Vertical sliding>

* The safety slide cover cannot be locked when the slide locking manual override is turned ON.

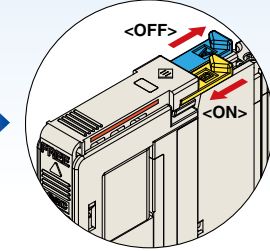

<Horizontal sliding>

● Visual check

Red lines visible from three directions can be checked to confirm whether the safety slide cover is unlocked (FREE).

Safety slide covers can be checked from their raised and lowered positions.

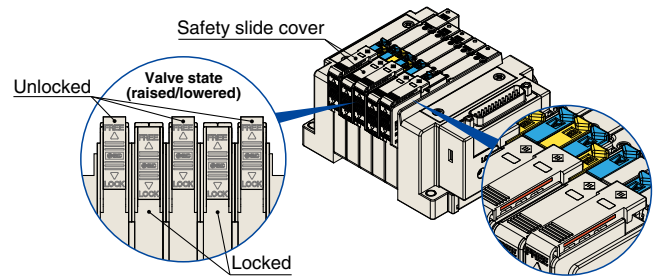
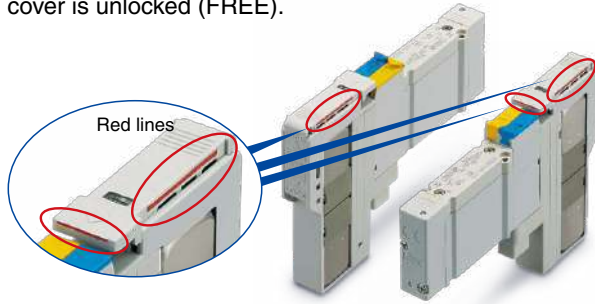

Made to Order

2-Position Single Solenoid Valve with Built-in Return Spring (Only rubber seal type)
SY3000/5000/7000-X350 p. 34

The main valve returns to the OFF position when it is not pressurized.

The main valve has a built-in spring which allows it to return to origin (the OFF position) when the supply pressure is stopped. This product can be used in SRP/CS (safety-related parts of control systems) constructions in accordance with safety standards (ISO 13849).

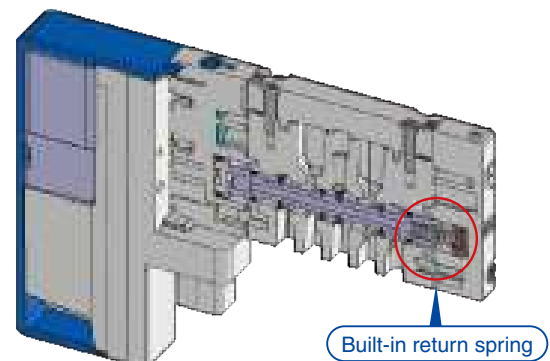

Built-in return spring

5-Port Solenoid Valve

To mount the piping on top

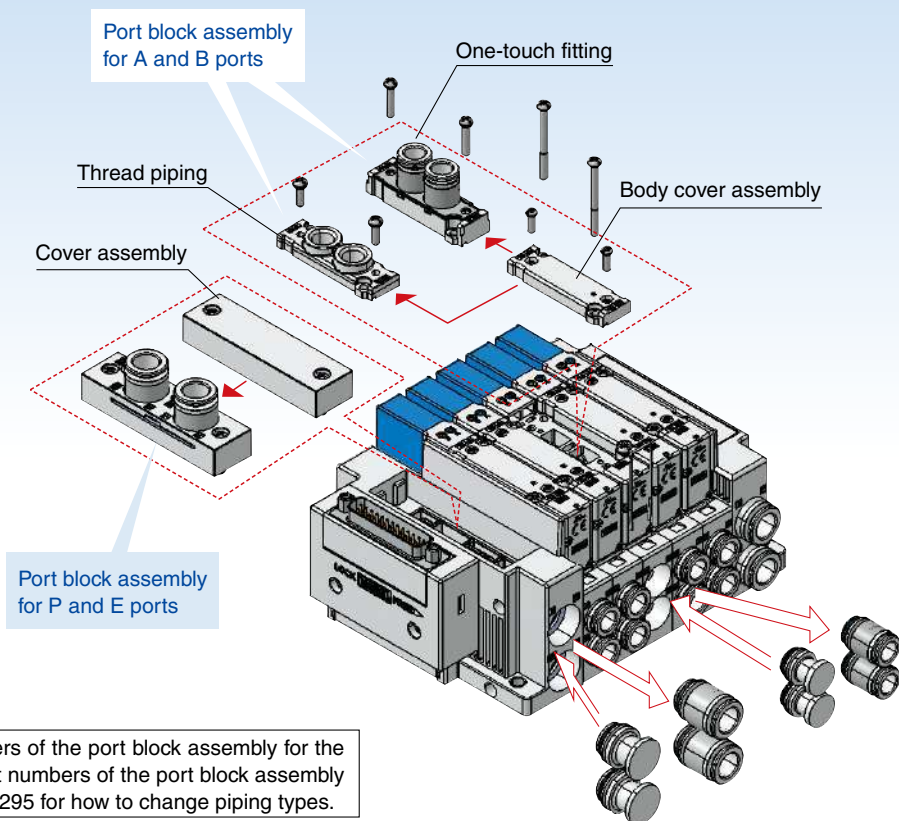

To mount the piping on the side

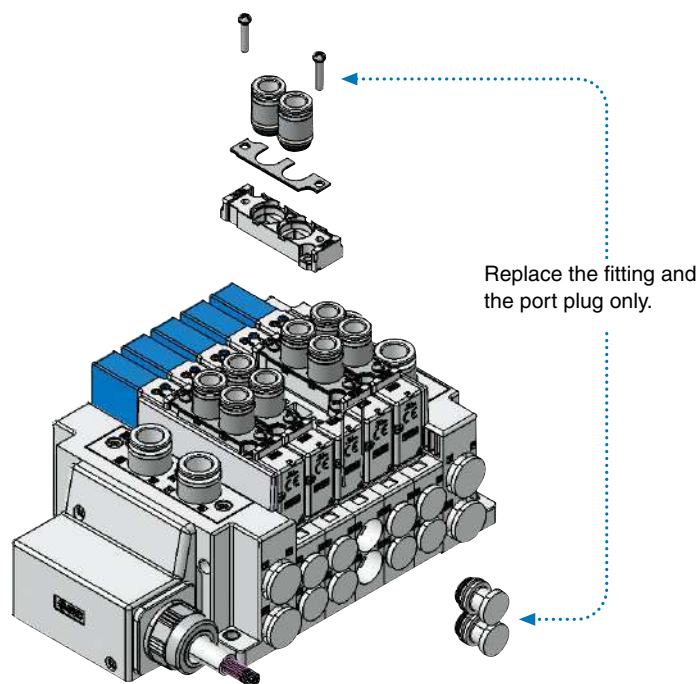

Mixed top-ported and side-ported mounting is possible.

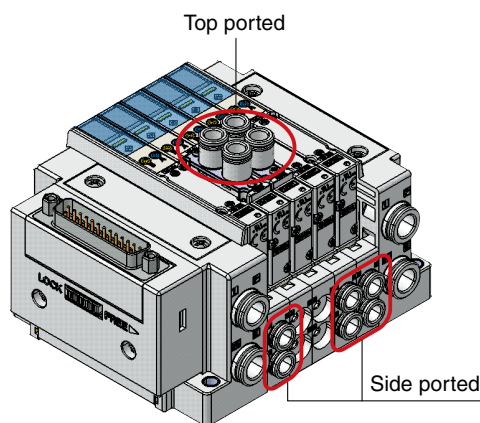

For SY3000 Blanking Plate with Output p. 211

■ The blanking plate extracts the individual signal of the manifold valve.



Application Examples

■ For the control of separately mounted valves

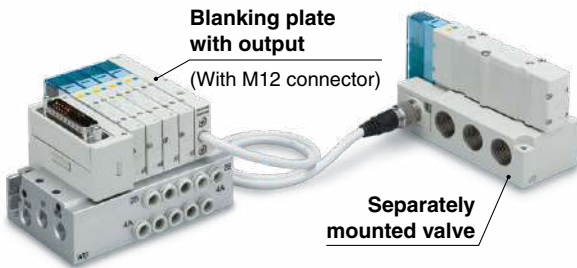

■ For the control of vacuum ejectors by means of Fieldbus unit signals

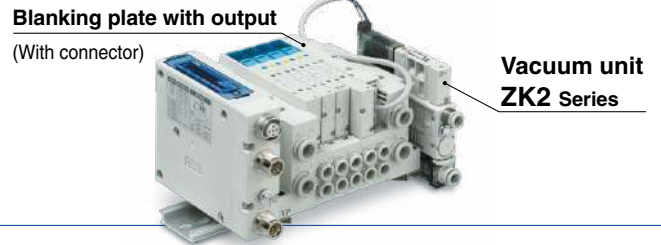

Valve with Pressure Sensor p. 32

■ Monitoring the output pressure of the solenoid valve contributes to preventive maintenance.

- The output pressure of the 4(A) and 2(B) ports can be detected.
- Detects errors such as incorrect switching, response delay, back pressure interference, pressure drop, etc.
- Identifies faulty parts of actuators, solenoid valves, etc.

■ Space saving, Reduced installation labor

- The required amount of space and installation labor can be reduced by directly mounting pressure switches on the solenoid valves.

Pressure sensor

- Rated pressure range: 0 to 1 MPa
- Power supply voltage: 12 to 24 VDC $\pm 10\%$
- Output specifications: Analog output
1 to 5 V (In rated pressure range)
Output impedance: Approx. 1 k Ω

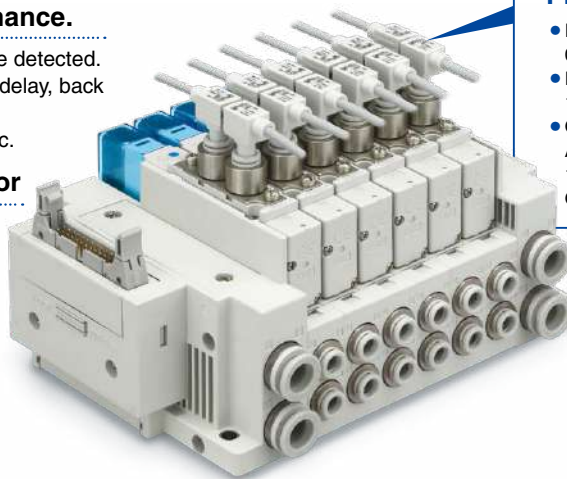

Mountable manifolds

Metal base	Side ported/Type 50□ Bottom ported/Type 51□
Connector connecting base	Side ported/Type 10□ Bottom ported/Type 11□

Application Examples

■ For the detection of output pressure

Operation can be checked by monitoring the pressure required to open or close air operated valves.

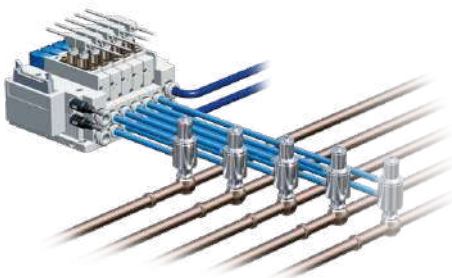

■ For the identification of faulty parts

A faulty part can quickly be identified by monitoring the operation of solenoid valves.

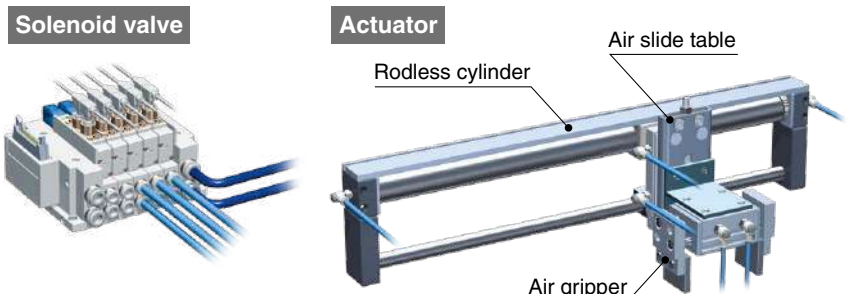

5-Port Solenoid Valve

Only for External Pilot Vacuum Release Valve with Restrictor SY³A□R Series p. 26

Vacuum suction and release can be controlled with a single valve!

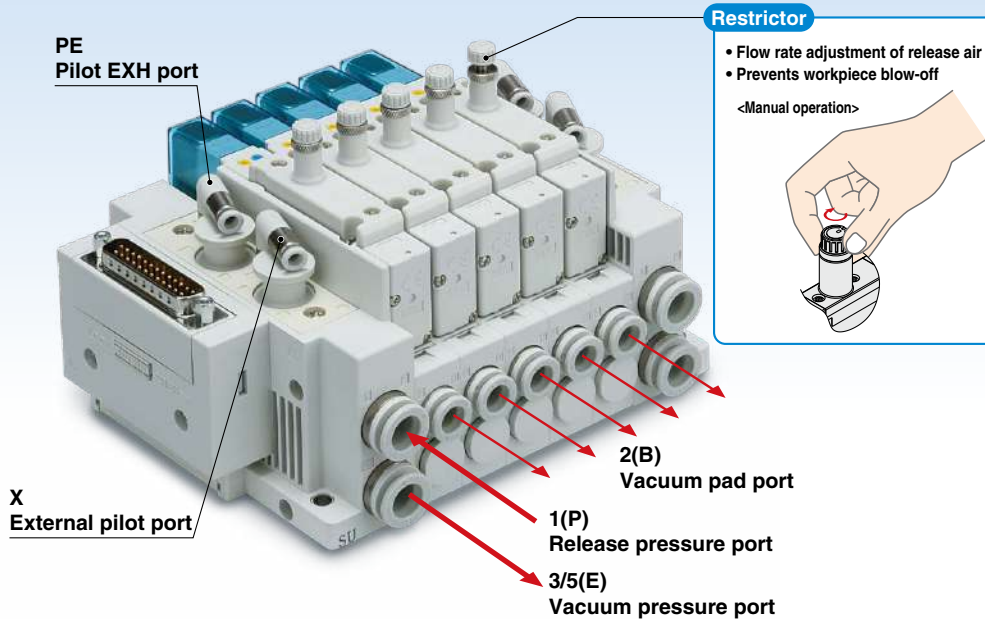

- Can be mounted on the same manifold as standard valves
 - * When an individual EXH spacer is used

■ Example

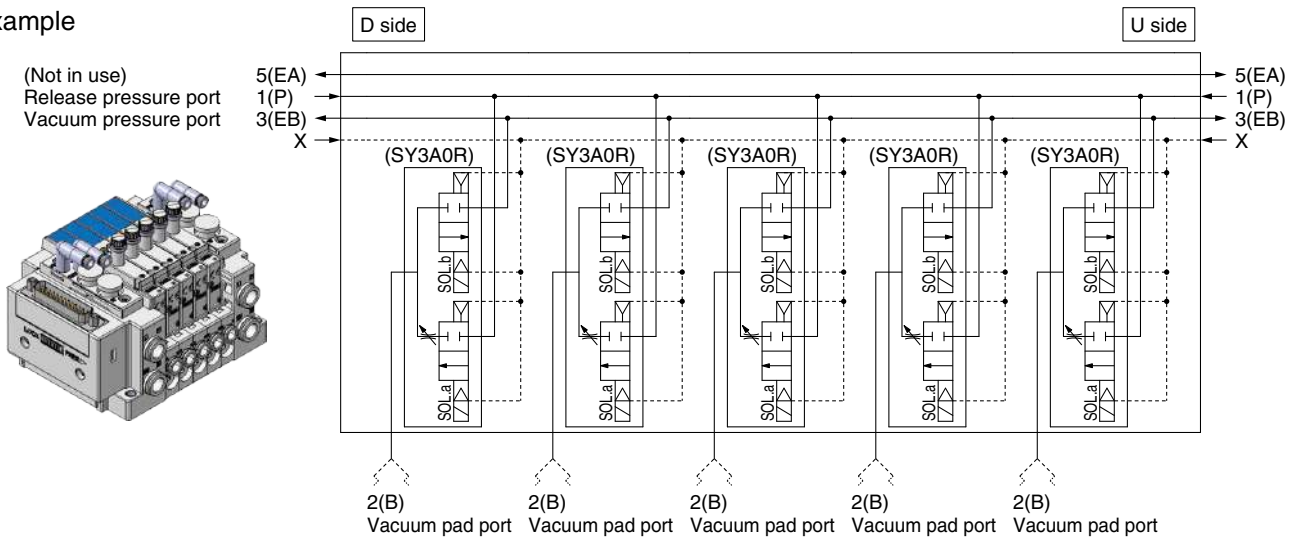

Mountable manifolds

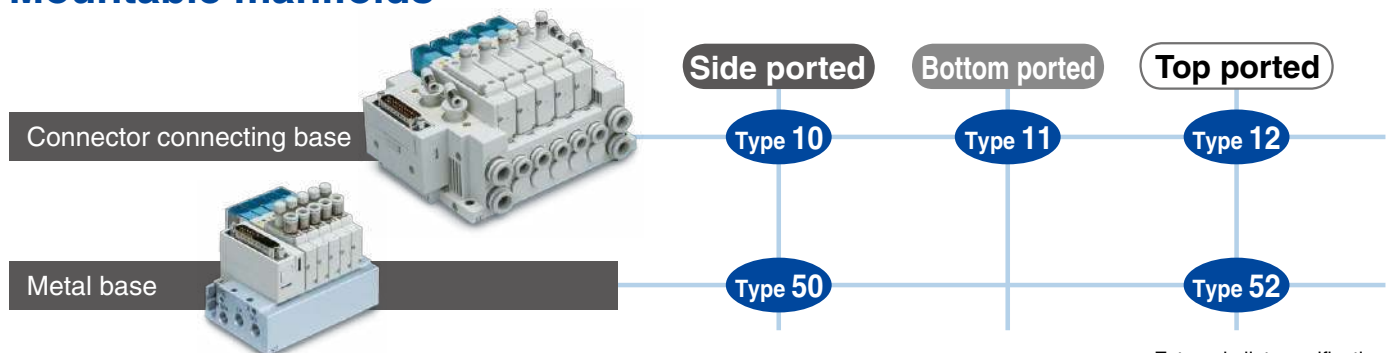

* External pilot specification

Applicable to EX600-W Series Wireless Systems p. 113 p. 123 p. 165 p. 169 p. 177

Noise resistance

- Uses the 2.4 GHz ISM frequency band
- Frequency hopping: Every 5 ms

Communication cables not required

- Reduced wiring work, space, and cost
- Minimized disconnection risk

High-speed connection

- From power supply ON to start of communication:
Min. 250 ms*1

*1 For wireless remote

Number of I/O points

- Max. 1280 inputs/1280 outputs
(Max. 128 inputs/128 outputs per module)

Communication response

- Wireless communication signal
Response time: **5 ms**

Compatible protocol

EtherNet/IP™



Application Examples

For tool changing

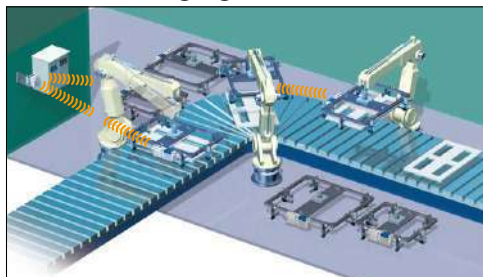

For spot welding

Welding environment



For rotary tables

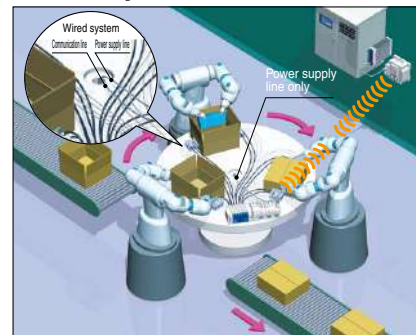

The EX260 series supports safety communication (PROFIsafe). p. 135-1

- This is a Fieldbus unit which supports safety standard ISO 13849-compliant safety circuit constructions.



PROFIsafe is established as an international standard (IEC 61784-3-3). It is a communication protocol that transmits safety-related data by PROFINET communication and can be used up until safety standards ISO 13849-1 PL e and IEC 61508/IEC 62061 SIL 3.

Using the safety communication protocol

Refer to the EX260 **Web Catalog** for details on units that support the safety communication protocol.

When using a manifold valve within an ISO 13849-compliant safety system, the device needs to be considered from both the pneumatic circuit and the electric side.

Devices (including valves) need to be selected based on whether their functions are in line with the safety level of the equipment as a whole.

The use of valves that have been validated as being compliant with ISO 13849-2 may be required.

For details on valves that have been validated, please contact SMC.

In addition, refer to "Safety Instructions" for precautions on model selection.

CONTENTS

Optimum Actuation Size Chart of Air Cylinder	p. 13
Valve Specifications (Specifications, Response Time, Weight)	p. 15
Valve Construction	p. 19

Manifold

Plug-in

Connector
Connecting
Base

p. 36

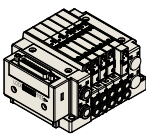
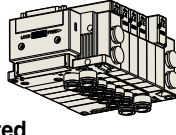
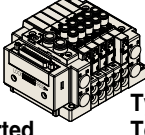























Type 10/
Side ported

Type 11/
Bottom ported

Type 12/
Top ported

Type 10/Side Ported, Type 11/Bottom Ported, Type 12/Top Ported

	Plug-in Connector Connecting Base	p. 37
	D-sub connector	
	D-sub Connector, Flat Ribbon Cable [IP40/67]	p. 41
	Terminal block box	
	Terminal Block Box (Spring Type) [IP67]	p. 59
	Terminal Block Box [IP67]	p. 64
	Lead Wire [IP67]	p. 77
	Terminal block box (Spring type)	
	Circular Connector [IP67]	p. 87
	EX500 Gateway Decentralized System 2 (128 Points) [IP67]	pp. 97, 109
	EX500 Gateway Decentralized System (64 Points) [IP67]	pp. 103, 111
	EX600 Integrated Type (For Input/Output) Serial Transmission System (Fieldbus System) [IP67]	p. 113
	EX245 Integrated Type (For Input/Output) Serial Transmission System [IP65]	p. 124-1
	EX250 Integrated Type (For Input/Output) Serial Transmission System [IP67]	p. 125
	EX260 Integrated Type (For Output) Serial Transmission System [IP67]	p. 133
	EX126 Integrated Type (For Output) Serial Transmission System [IP67]	p. 141
	EX120 Integrated Type (For Output) Serial Transmission System [IP20]	p. 149
	EX180 Integrated Type (For Output) Serial Transmission System [IP20]	p. 156-1
	EX120 Integrated Type (For Output) Serial Transmission System [IP20]	p. 156-1
	EX180 Integrated Type (For Output) Serial Transmission System [IP20]	p. 156-1
	Type 10/Side Ported: Common Dimensions (External Pilot, Silencer, Elbow Fittings, Slide Locking Manual Override)	p. 157
	Type 11/Bottom Ported: Common Dimensions	p. 160
	Type 12/Top Ported: Common Dimensions	p. 162
	Plug-in Mixed Mounting Type Manifold	p. 165
	Mixed mounting	
	Manifold Exploded View [Exploded View, Manifold Parts Nos.]	p. 181
	How to Increase Connector Type Manifolds	p. 197
	One-touch Fitting, Plug Assembly Part Nos.	p. 202
	Manifold Options	p. 203

Manifold

Plug-in Metal Base p. 220

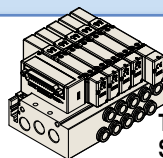

Type 50/
Side ported

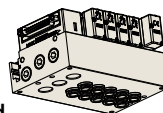

Type 51/
Bottom ported

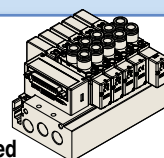

Type 52/
Top ported

Type 50/Side Ported, Type 51/Bottom Ported, Type 52/Top Ported

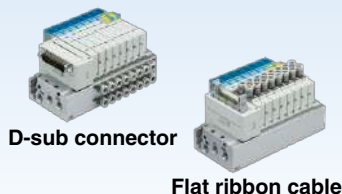

D-sub connector

Flat ribbon cable



EX510

Plug-in Metal Base p. 221

D-sub Connector, Flat Ribbon Cable [IP40]

Type 50/Side Ported p. 223

Type 51/Bottom Ported p. 223

Type 52/Top Ported p. 243

Wiring Specifications p. 248

EX510 Gateway Type Serial Transmission System [IP20]

Type 50/Side Ported p. 251

Type 51/Bottom Ported p. 251

Type 52/Top Ported p. 261

Manifold Exploded View [Exploded View, Manifold Parts Nos.] p. 266

One-touch Fitting, Plug Assembly Part Nos. p. 267

Manifold Options p. 268

Sub-plate

Plug-in Sub-plate p. 280

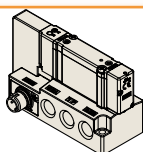

M12 connector



Plug-in Sub-plate Specifications (M12 Connector) p. 281

Sub-plate Parts Nos. p. 283

Valve Replacement Parts p. 22

With Residual Pressure Release Valve p. 24

Vacuum Release Valve with Restrictor p. 26

Valve with Pressure Sensor p. 32

Made to Order for Valves p. 34

Specific Product Precautions p. 290

Model Index p. 298

M8/M12 Connector

PCA/EX9/EX500 Series



- Communication Cable/Connector

EtherNet/IP®



EtherCAT®

ETHERNET
POWERLINK

CC-Link

DeviceNet®



- Power Supply Cable/Connector

- Accessory Between the Sensor/Switch and the Input Device

- Other Accessories

- Made to Order

- Specific Product Precautions

Communication Cable/Connector ▶ p. 1512 to 1523

● A lineup featuring products applicable to all communication standards

The SMC Fieldbus (SI) Unit can be connected to the PLC (controller) and communication units from other manufacturers with cables with connectors and field-wireable connectors (with shield) applicable to each of the standards.

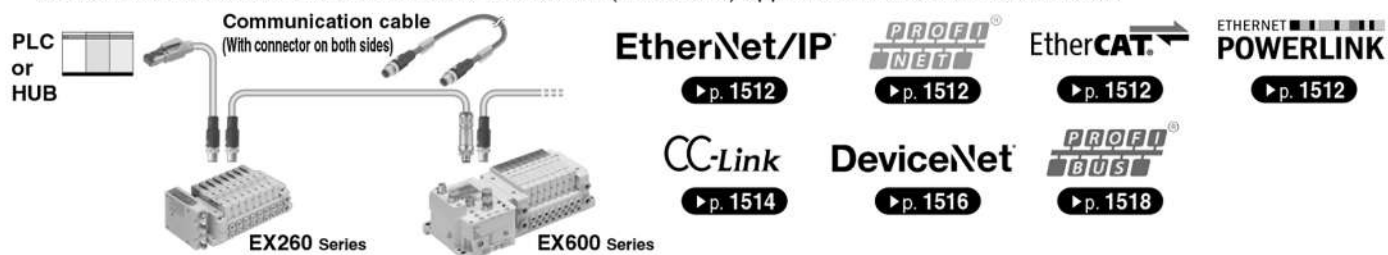

Communication cable	Field-wireable communication connector	Communication cable (With connector on both sides)
<p>SPEEDCON</p> <p>Socket (Female) ④ For CC-Link ⑧ For DeviceNet® ⑭ For PROFIBUS DP</p> <p>SPEEDCON</p> <p>Plug (Male) ⑤ For CC-Link ⑨ For DeviceNet® ⑮ For PROFIBUS DP ② For EtherNet/IP™, PROFINET, EtherCAT, Ethernet POWERLINK * ② and ③ are used in combination with each other.</p> <p>Plug (Male) ① For EtherNet/IP™, PROFINET, EtherCAT, Ethernet POWERLINK</p>	<p>SPEEDCON * Excluding ③</p> <p>Plug (Male) ⑥ For CC-Link ⑩ For DeviceNet® ⑬ For PROFIBUS DP ③ For EtherNet/IP™, PROFINET, EtherCAT, Ethernet POWERLINK * ② and ③ are used in combination with each other.</p> <p>SPEEDCON</p> <p>Socket (Female) ⑦ For CC-Link ⑫ For DeviceNet® ⑰ For PROFIBUS DP</p> <p>RJ45</p>	<p>● For EtherNet/IP™, PROFINET, EtherCAT, Ethernet POWERLINK ● For CC-Link ● For DeviceNet®</p> <p>SPEEDCON</p>
<p>Terminating resistor</p> <p>Connects to the communication port of the communication unit connected at the end</p> <p>⑬ For DeviceNet® (Plug) ⑱ For PROFIBUS DP (Plug/B-coded)</p>		

● Product Table

Description	Application	No.	SMC part no.	Name
Communication cable (With connector on one side)	For Fieldbus communication	①	EX9-AC□EN-PSRJ	Communication cable for EtherNet/IP™, PROFINET, EtherCAT, Ethernet POWERLINK (Plug/D-coded/RJ45)
		②	PCA-1446566	Communication cable for EtherNet/IP™, PROFINET, EtherCAT, Ethernet POWERLINK (Plug/D-coded)
		④	PCA-1567720	Communication cable for CC-Link (Socket)
		⑤	PCA-1567717	Communication cable for CC-Link (Plug)
		⑧	PCA-1557633	Communication cable for DeviceNet® (Socket)
		⑨	PCA-1557646	Communication cable for DeviceNet® (Plug)
		⑭	PCA-1557688	Communication cable for PROFIBUS DP (Socket/B-coded)
		⑮	PCA-1557691	Communication cable for PROFIBUS DP (Plug/B-coded)
Communication cable (With connector on both sides)	For Fieldbus communication		EX9-AC□EN-PSPS	Communication cable for EtherNet/IP™, PROFINET, EtherCAT, Ethernet POWERLINK (Straight)
			EX9-AC□EN-PAPA	Communication cable for EtherNet/IP™, PROFINET, EtherCAT, Ethernet POWERLINK (Angle)
			EX9-AC□MJ-SSPS	Communication cable for CC-Link (Straight)
			EX9-AC□MJ-SAPA	Communication cable for CC-Link (Angle)
			EX9-AC□DN-SSPS	Communication cable for DeviceNet® (Straight)
			EX9-AC□DN-SAPA	Communication cable for DeviceNet® (Angle)
Field-wireable communication connector	For Fieldbus communication	③	PCA-1446553	Field-wireable connector for EtherNet/IP™, PROFINET, EtherCAT, Ethernet POWERLINK (Plug/D-coded/Fast connection technology)
		⑥	PCA-1075526	Field-wireable connector for CC-Link (Plug/Push-in type)
		⑦	PCA-1075527	Field-wireable connector for CC-Link (Socket/Push-in type)
		⑩	PCA-1075528	Field-wireable connector for DeviceNet® (Plug/Push-in type)
		⑫	PCA-1075529	Field-wireable connector for DeviceNet® (Socket/Push-in type)
		⑬	PCA-1075530	Field-wireable connector for PROFIBUS DP (Plug/B-coded/Push-in type)
		⑰	PCA-1075531	Field-wireable connector for PROFIBUS DP (Socket/B-coded/Push-in type)
Terminating resistor	For Fieldbus communication	⑱	PCA-1557675	Terminating resistor for DeviceNet® (M12)
		⑲	PCA-1557727	Terminating resistor for PROFIBUS DP (M12/B-coded)

Power Supply Cable/Connector ▶ p. 1524 to 1531

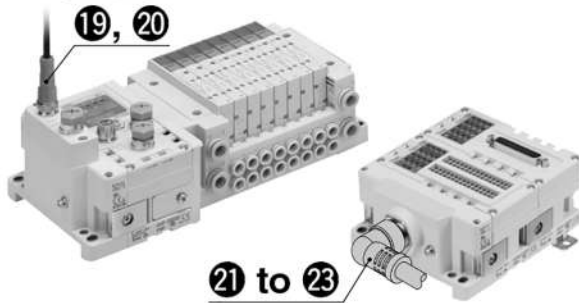
EX600 ▶ p. 1524

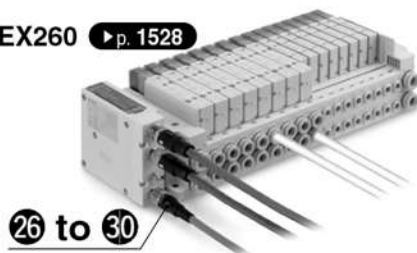
EX500 ▶ p. 1526

EX260 ▶ p. 1528

EX250 ▶ p. 1530

● Product Table

Series	Protocols	No.	Part no.	Connector type	Cable length		
EX600	EtherNet/IP™ PROFINET	19	PCA-15649□	M12, 5 pins, B-coded, Socket, Straight, SPEEDCON	2 m, 6 m		
		20	PCA-15649□	M12, 5 pins, B-coded, Socket, Angle, SPEEDCON			
	EtherCAT PROFIBUS DP DeviceNet® CC-Link	End plate EX600-ED3□	21	PCA-15588□	7/8 inch, 5 pins, Socket, Straight	2 m, 6 m	
			22	PCA-15588□	7/8 inch, 5 pins, Socket, Angle		
			23	PCA-1578081	Field-wireable connector, 7/8 inch, 5 pins, Socket, Straight		—
EX500	EtherNet/IP™	24	PCA-141□	7/8 inch, 4 pins, Socket, Straight	2 m, 6 m		
		25	PCA-141□	7/8 inch, 4 pins, Socket, Angle			
	PROFINET PROFIBUS DP	End plate EX500-ED3□	21	PCA-15588□	7/8 inch, 5 pins, Socket, Straight	2 m, 6 m	
			22	PCA-15588□	7/8 inch, 5 pins, Socket, Angle		
			26	EX500-AP□-S	M12, 5 pins, A-coded, Socket, Straight		1 m, 5 m
27	EX500-AP□-A	M12, 5 pins, A-coded, Socket, Angle					
EX260	EtherNet/IP™ PROFINET	26	EX500-AP□-S	M12, 5 pins, A-coded, Socket, Straight	1 m, 5 m		
		27	EX500-AP□-A	M12, 5 pins, A-coded, Socket, Angle			
	EtherCAT DeviceNet® PROFIBUS DP CC-Link	End plate EX260-ED3□	28	PCA-140180□	M12, 5 pins, A-coded, Socket, Straight, SPEEDCON	1.5 m, 3 m, 5 m	
			29	EX9-AC□-1	M12, 5 pins, B-coded, Socket, Straight		1 m, 3 m, 5 m
			30	PCA-140180□	M12, 5 pins, B-coded, Socket, Straight, SPEEDCON		
EX250	DeviceNet® CC-Link	End plate EX250-ED3□	29	EX9-AC□-1	M12, 5 pins, B-coded, Socket, Straight	1 m, 3 m, 5 m	
			26	EX500-AP□-S	M12, 5 pins, A-coded, Socket, Straight		1 m, 5 m

Accessory Between the Sensor/Switch and the Input Device ▶ p. 1532 to 1534

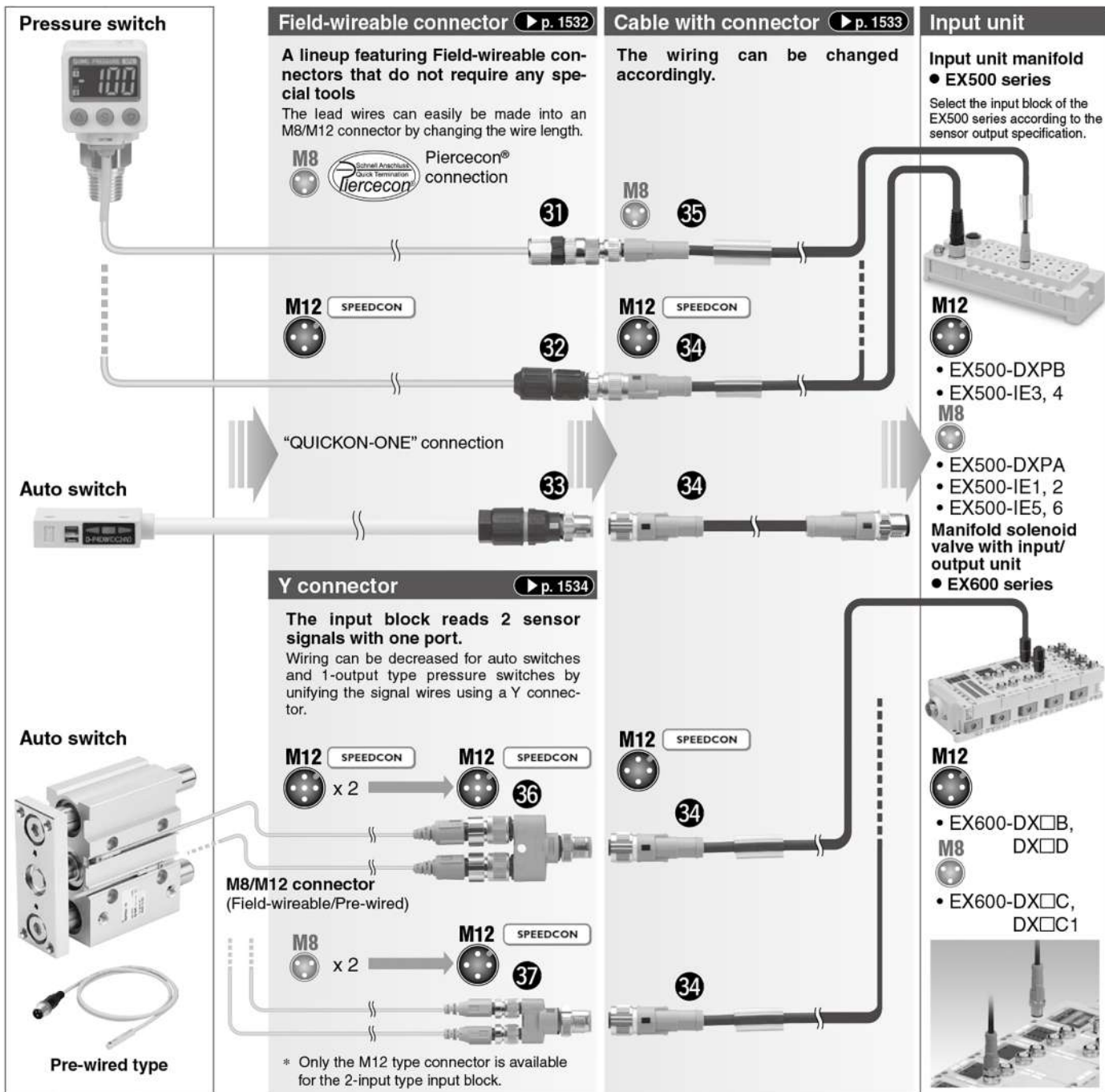
● Connection between connectors and products



● Product Table

Description	Application	No.	SMC part no.	Name
Cable with connector	For sensor	34	PCA-1557769	Cable with M12 connector (4 pins/3 m)
		35	PCA-1557772	Cable with M8 connector (3 pins/3 m)
Field-wireable connector	For sensor	31	PCA-1557730	Field-wireable connector (M8/3 pins/Plug/Piercecon® connection)
		32	PCA-1557743	Field-wireable connector
		33	PCA-1557756	(M12/4 pins/Plug/QUICKON-ONE connection/SPEEDCON)
Y connector	For sensor	36	PCA-1557785	Y connector (2 x M12 (5 pins)-M12 (5 pins)/SPEEDCON)
		37	PCA-1557798	Y connector (2 x M8 (3 pins)-M12 (4 pins)/SPEEDCON)

Other Accessories (EX500/EX9)

▶ p. 1535 to 1537

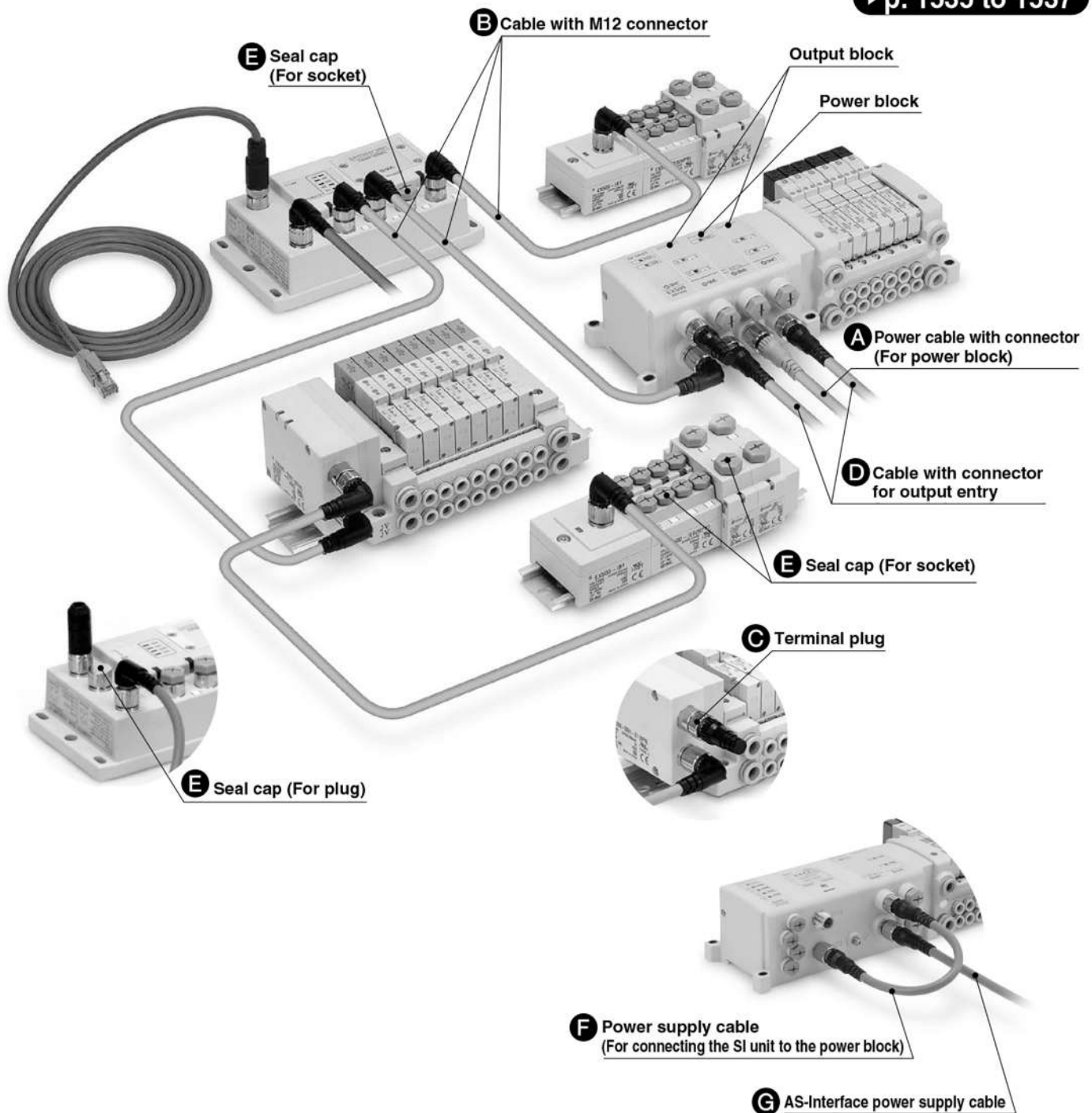

Description	Application	No.	SMC part no.	Name
Cable with connector	For power block	A	EX9-AC□□□-1	Power cable with connector (Socket/B-coded)
	For EX500	B	EX500-AC□□□-SSPS	Cable with M12 connector (8 pins/Both straight)
			EX500-AC□□□-SAPA	Cable with M12 connector (8 pins/Both angle)
	For output entry	D	EX9-AC□□□-7	Cable with M12 connector (Plug/A-coded)
Terminal plug	For EX500	C	EX500-AC000-S	Terminal plug (M12/8 pins)
Seal cap	For plug	E	EX500-AWTP	Seal cap (M12/For plug)
			EX9-AWES	Seal cap (M8/For socket)
			EX9-AWTS	Seal cap (M12/For socket)
Power supply cable	For connecting the SI unit to the power block	F	EX9-AC002-□	Power supply cable (For connecting the SI unit to the power block)
	For the AS-Interface power supply	G	EX9-AC□□□-5	AS-Interface power supply cable (5 pins/Both straight)

CONTENTS

Fieldbus Related Accessories

M8/M12 Connector *PCA/EX9/EX500 Series*

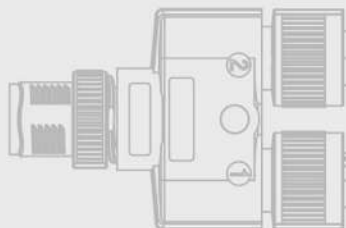
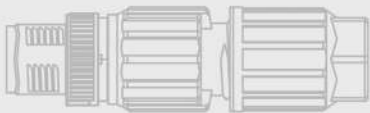
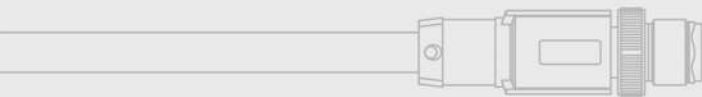
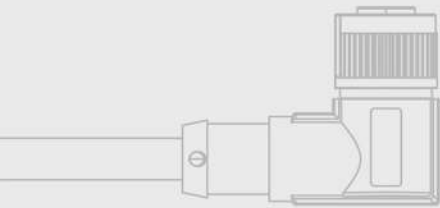

Communication Cable/Connector

EtherNet/IP™, PROFINET, EtherCAT, Ethernet POWERLINK	p. 1512
CC-Link	p. 1514
DeviceNet®	p. 1516
PROFIBUS DP	p. 1518
Communication Cable	p. 1519
Field-wireable Communication Connector	p. 1523
Terminating Resistor	p. 1523

Power Supply Cable/Connector

EX600 Series	p. 1524
EX500 Series	p. 1526
EX260 Series	p. 1528
EX250 Series	p. 1530

Accessory Between the Sensor/Switch and the Input Device

Field-wireable Connector	p. 1532
Cable with Connector	p. 1533
Y Connector	p. 1534

Other Accessories

A Power Cable with Connector (For power block) ..	p. 1535
B Cable with M12 Connector	p. 1535
C Terminal Plug	p. 1536
D Cable with Connector for Output Entry	p. 1536
E Seal Cap: M12 Connector (For plug)	p. 1536
E Seal Cap: M8, M12 Connector (For socket)	p. 1536
F Power Supply Cable (For connecting the SI unit to the power block) ..	p. 1537
G AS-Interface Power Supply Cable	p. 1537

Made to Order

Communication Cable	p. 1538
Power Supply Cable	p. 1539

Specific Product Precautions	p. 1540
------------------------------------	---------

Communication Cable/Connector

M12

EtherNet/IP[®] PROFINET[®] EtherCAT[®] ETHERNET POWERLINK



Example of Connection

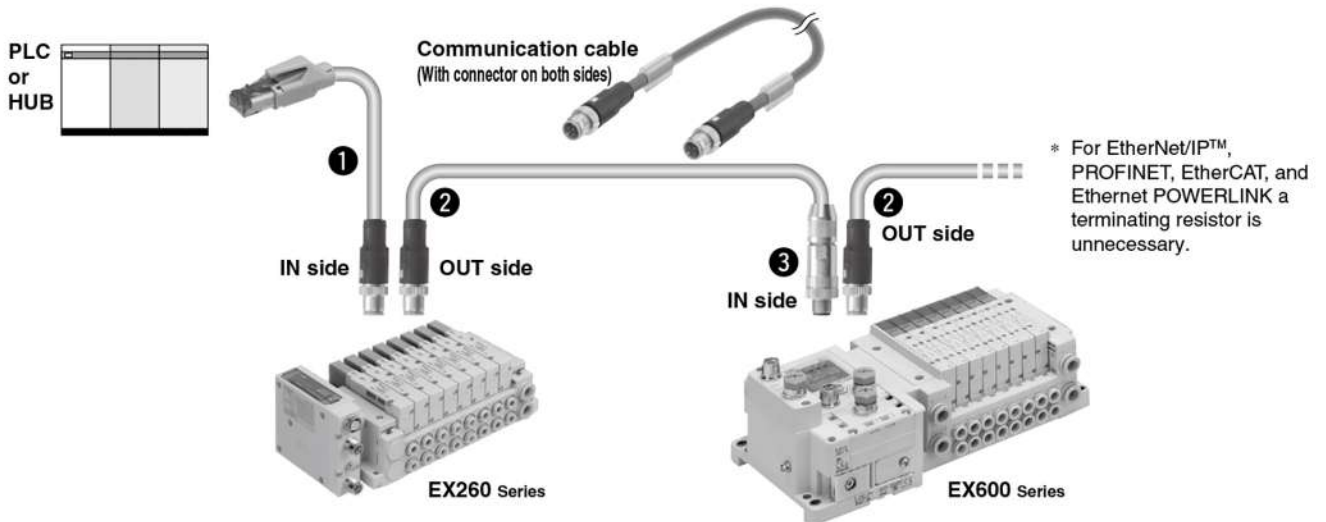



Specifications

Description		Communication cable (With connector on one side)		Field-wireable connector
Part no. (Cable length)		EX9-AC010EN-PSRJ (1 m) EX9-AC020EN-PSRJ (2 m) EX9-AC030EN-PSRJ (3 m) EX9-AC050EN-PSRJ (5 m) EX9-AC100EN-PSRJ (10 m)	PCA-1446566	PCA-1446553
Product image		Plug-RJ45	SPEEDCON Plug	Plug
Number of functional poles		M12: 4 pins, RJ45: 8 pins	M12: 4 pins	M12: 4 pins
Key type		M12: D coded		
Pin assignment		 Plug, D-coded (Viewed from the plug side)	1 (Yellow): TD+ 2 (White): RD+ 3 (Orange): TD- 4 (Blue): RD- (PCA-1446566)	1 (Orange/White): TD+ 2 (Green/White): RD+ 3 (Orange): TD- 4 (Green): RD- (EX9-AC□EN-PSRJ.PCA-1446553)
Wiring	Fixed cable length	1 m, 2 m, 3 m, 5 m, 10 m	5 m	—
	Cable O.D.	6.4 mm	6.5 mm	Applicable cable*1: 4.0 to 8.0 mm
	Conductor nominal cross section	0.14 mm ² /AWG26	0.34 mm ² /AWG22	0.14 to 0.34 mm ² /AWG26 to 22
	Wire O.D.	0.5 mm	1.55 mm	—
Connection type		— QUICKON connection		
Rating/Performance	Rated current	1 A	4 A	1.75 A
	Rated voltage	100 V	48 VAC/60 VDC	60 V
	Contact resistance	10 mΩ or less		
	Insulation resistance	100 MΩ or more		
	Withstand voltage	0.7 kV	1.4 kV	0.8 kV
	Ambient temperature	Connector: -25 to +60°C Cable: -40 to +80°C	-40 to +70°C	-40 to +85°C
	Min. bending radius (Fixed)	26 mm	19.5 mm	—
	Protection class	M12: IP67 (Only with screw tightened), RJ45: IP20	M12: IP67 (Only with screw tightened)	
Allowable repeated insertion/withdrawal		100		
Material	Material of knurl	Zinc die-cast (Nickel alloy)	Zinc die-cast (Nickel plating)	Brass (Nickel plating)
	Contact (Surface treatment)	M12: CuZn (Au plating (Ni underplating)) RJ45: CuSn (Au plating (Ni underplating))	CuZn (Au plating (Ni underplating))	CuSn (Au plating (Ni underplating))
	Connector material	TPU (UL94 HB)		PA66 (UL94 V0)
	Material of sheath (Sheath color)	PUR (Blue (RAL 5021 equivalent))	PVC (Green (RAL 6018 equivalent))	—
Weight		1 m: Approx. 70 g 5 m: Approx. 252 g 2 m: Approx. 116 g 10 m: Approx. 479 g 3 m: Approx. 161 g	Approx. 350 g	Approx. 45.6 g

*1 The shaded sections show the specifications for the applicable cable. Adaptation for the connector may vary on account of the conductor construction of the electric wire.

Specifications

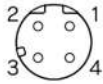
Description		Communication cable (With straight connector on both sides)	Communication cable (With angle connector on both sides)
Part no. (Cable length)		EX9-AC005EN-PSPS (0.5 m) EX9-AC010EN-PSPS (1 m) EX9-AC020EN-PSPS (2 m) EX9-AC030EN-PSPS (3 m) EX9-AC050EN-PSPS (5 m) EX9-AC100EN-PSPS (10 m)	EX9-AC005EN-PAPA (0.5 m) EX9-AC010EN-PAPA (1 m) EX9-AC020EN-PAPA (2 m) EX9-AC030EN-PAPA (3 m) EX9-AC050EN-PAPA (5 m) EX9-AC100EN-PAPA (10 m)
Product image		 <p style="text-align: center;">Both straight</p>	 <p style="text-align: center;">Both angle</p>
Number of functional poles		M12: 4 pins	
Key type		M12: D-coded	
Pin assignment		 <p style="text-align: center;">Plug, D-coded (Viewed from the plug)</p> <p> 1 (Yellow) : TD+ 2 (White) : RD+ 3 (Orange) : TD- 4 (Blue) : RD- </p>	
Wiring	Fixed cable length	0.5 m, 1 m, 2 m, 3 m, 5 m, 10 m	
	Cable O.D.	6.5 mm	
	Conductor nominal cross section	0.34 mm ² /AWG22	
	Wire O.D. (Including insulating material)	1.55 mm	
Rating/Performance	Rated current	4 A	
	Rated voltage	48 VAC/60 VDC	
	Contact resistance	10 mΩ or less	
	Insulation resistance	100 MΩ or more	
	Withstand voltage	1.4 kV	
	Ambient temperature	-40 to 70°C	
	Min. bending radius (Fixed)	19.5 mm	
	Protection class	M12: IP67 (Only with screw tightened)	
Material	Allowable repeated insertion/withdrawal	100	
	Material of knurl	Zinc die-cast (Nickel plating)	
	Contact (Surface treatment)	CuSn (Au plating (Ni underplating))	
	Connector material	TPU (UL94 HB)	
	Material of sheath (Sheath color)	PVC (Green (RAL 6018 equivalent))	
Weight		0.5 m: Approx. 85g 1 m: Approx. 135g 2 m: Approx. 215g 3 m: Approx. 305g 5 m: Approx. 480g 10 m: Approx. 905g	0.5 m: Approx. 85g 1 m: Approx. 135g 2 m: Approx. 215g 3 m: Approx. 305g 5 m: Approx. 480g 10 m: Approx. 905g

Communication Cable/Connector

M12

CC-Link



Example of Connection

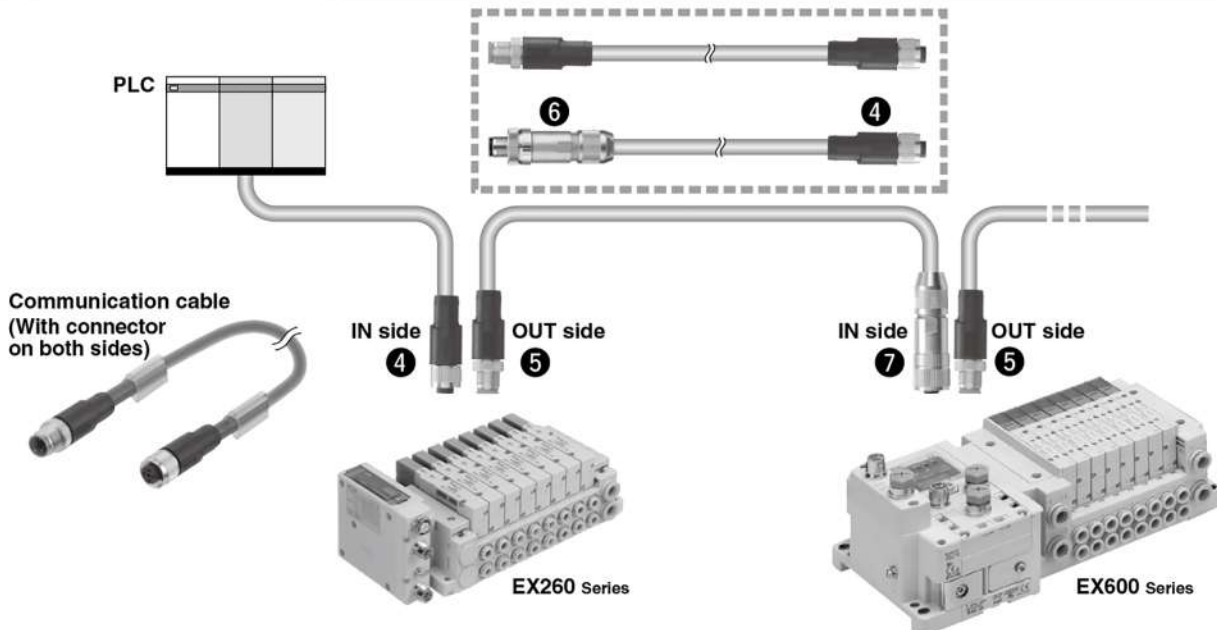



Specifications

Description		Communication cable (With connector on one side)		Field-wireable connector		
Part no.		PCA-1567720	PCA-1567717	PCA-1075526	PCA-1075527	
Product image						
Number of functional poles		M12: 4 pins				
Key type		A-coded (Normal key)				
Pin assignment		 Plug, A-coded*1		 Socket, A-coded		
		* Number of holes: 5, Total number of pins: 4		1: SLD (Shield wire) 2: DB (White) 3: DG (Yellow) 4: DA (Blue)		
		(Viewed from the plug/socket side)				
Wiring	Fixed cable length	5 m		—		
	Cable O.D.	7.7 mm		Applicable cable*2	4.0 to 8.0 mm	
	Conductor nominal cross section	Data pair	0.5 mm ² /AWG20		0.14 to 0.75 mm ² /AWG26 to 18 (Solid cable/Flexible cable)	
		Drain	0.34 mm ² /AWG22		0.08 to 0.5 mm ² /AWG28 to 20 (With ferrule)	
	Wire O.D. (Including insulating material)	2.55 mm		—		
Connection type		—		Push-in type		
Rating/Performance	Rated current	4 A				
	Rated voltage	48 VAC/60 VDC				
	Contact resistance	10 mΩ or less		10 mΩ or less		
	Insulation resistance	100 MΩ or more				
	Withstand voltage	1.4 kV				
	Ambient temperature	-20 to +60°C		-40 to +85°C		
	Connector					
	Cable					
Min. bending radius (Fixed)		77 mm		—		
Protection class		IP67 (Only with screw tightened)				
Allowable repeated insertion/withdrawal		100				
Material of knurl		Zinc die-cast (Nickel plating)				
Contact (Surface treatment)		CuSn (Au plating (Ni underplating))				
Connector material		TPU (UL94 HB)		PA66 (UL94 V0)		
Material of sheath (Sheath color)		PVC (Red)		—		
Weight		Approx. 306 g	Approx. 308 g	Approx. 37 g	Approx. 42 g	

*1 Can also be connected to an M12 5-pin socket A-coded connector

*2 The shaded sections show the specifications for the applicable cable. Adaptation for the connector may vary on account of the conductor construction of the electric wire.

Specifications

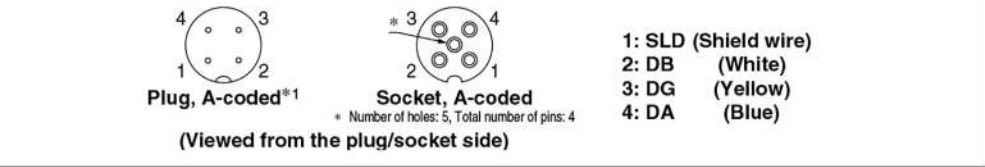
Description		Communication cable (With straight connector on both sides)	Communication cable (With angle connector on both sides)
Part no. (Cable length)		EX9-AC005MJ-SSPS (0.5 m) EX9-AC010MJ-SSPS (1 m) EX9-AC020MJ-SSPS (2 m) EX9-AC030MJ-SSPS (3 m) EX9-AC050MJ-SSPS (5 m) EX9-AC100MJ-SSPS (10 m)	EX9-AC005MJ-SAPA (0.5 m) EX9-AC010MJ-SAPA (1 m) EX9-AC020MJ-SAPA (2 m) EX9-AC030MJ-SAPA (3 m) EX9-AC050MJ-SAPA (5 m) EX9-AC100MJ-SAPA (10 m)
Product image			
Number of functional poles		M12: 5 pins	
Key type		A-coded (Normal key)	
Pin assignment		 <p> * Number of holes: 5, Total number of pins: 4 (Viewed from the plug/socket side) </p>	
Wiring	Fixed cable length	0.5 m, 1 m, 2 m, 3 m, 5 m, 10 m	
	Cable O.D.	7.7 mm	
	Conductor nominal cross section	0.5 mm ² /AWG20	
	Wire O.D. (Including insulating material)	1.4 mm	
Rating/Performance	Rated current	4 A	
	Rated voltage	48 VAC/60 VDC	
	Contact resistance	10 mΩ or less	
	Insulation resistance	100 MΩ or more	
	Withstand voltage	1.4 kV	
	Ambient temperature	-20 to +60°C	
	Min. bending radius (Fixed)	77 mm	
	Protection class	IP67 (Only with screw tightened)	
Material	Allowable repeated insertion/withdrawal	100	
	Material of knurl	Zinc die-cast (Nickel plating)	
	Contact (Surface treatment)	CuSn (Au plating (Ni underplating))	
	Connector material	TPU (UL94 HB)	
Material of sheath (Sheath color)		PVC (Red)	
Weight		0.5 m: Approx. 80 g 1 m: Approx. 120 g 2 m: Approx. 200 g 3 m: Approx. 280 g 5 m: Approx. 440 g 10 m: Approx. 840 g	0.5 m: Approx. 80 g 1 m: Approx. 120 g 2 m: Approx. 205 g 3 m: Approx. 285 g 5 m: Approx. 450 g 10 m: Approx. 865 g

*1 Can also be connected to an M12 5-pin socket A-coded connector

Communication Cable/Connector

M12



DeviceNet

Example of Connection

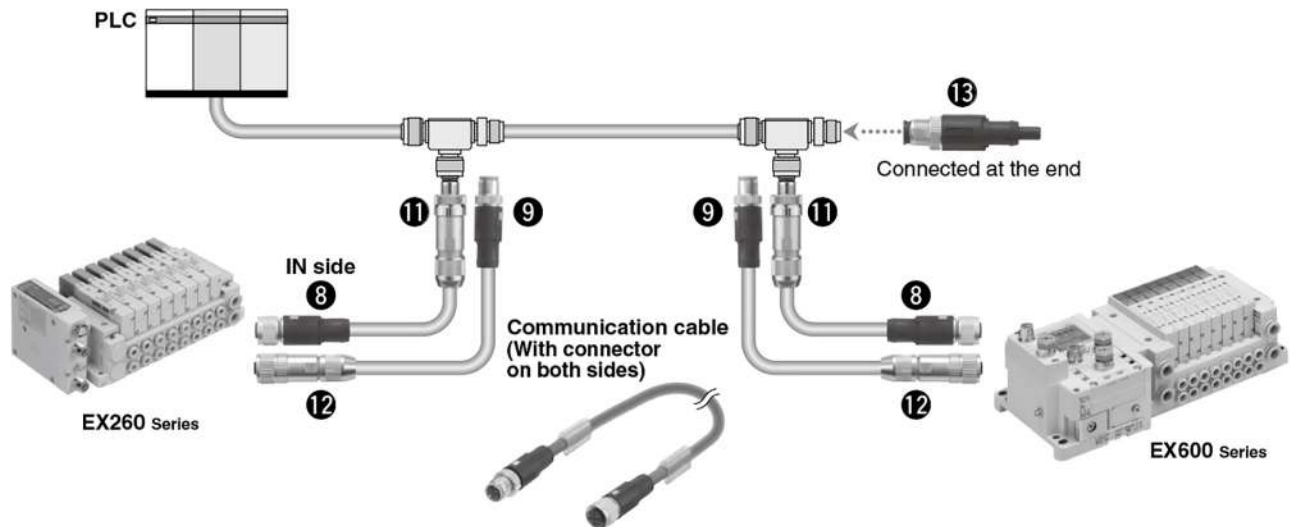



Specifications

Description		Communication cable (With connector on one side)		Field-wireable connector		Terminating resistor	
Part no. (Cable length)		PCA-1557633	PCA-1557646	PCA-1075528	PCA-1075529	PCA-1557675	
Product image							
Number of functional poles		M12: 5 pins					
Key type		A-coded (Normal key)					
Pin assignment		<p>Plug, A-coded Socket, A-coded (Viewed from the plug/socket side)</p>		DeviceNet® / CANopen*2 1: DRAIN 1: — 2: V+ (Red) 2: — 3: V- (Black) 3: CAN GND 4: CAN H (White) 4: CAN H 5: CAN L (Blue) 5: CAN L		1: DRAIN: NC 2: V+: NC 3: V-: NC 4: CAN H 5: CAN L	
Wiring	Fixed cable length	5 m		—		—	
	Cable O.D.	6.7 mm		Applicable cable*1	4.0 to 8.0 mm		
	Conductor nominal cross section	Power pair	0.34 mm ² /AWG22		0.14 to 0.75 mm ² /AWG26 to 18 (Solid cable/Flexible cable)		
		Data pair	0.25 mm ² /AWG24	0.08 to 0.5 mm ² /AWG28 to 20 (With ferrule)			
	Wire O.D. (including insulating material)	Power pair	1.4 mm	—			
	Data pair	1.95 mm	—				
Connection type		—		Push-in type		—	
Rating/Performance	Rated current		4 A		4 A		
	Rated voltage		48 VAC/60 VDC		48 VAC/60 VDC		
	Contact resistance		10 mΩ or less		10 mΩ or less		5 mΩ or less
	Insulation resistance		100 MΩ or more		100 MΩ or more		—
	Withstand voltage		1.0 kV		1.0 kV		—
	Ambient temperature	Connector	-20 to +80°C		-40 to +85°C		-25 to +90°C
		Cable					
	Min. bending radius (Fixed)		67 mm		—		—
Protection class		IP67 (Only with screw tightened)					
Allowable repeated insertion/withdrawal		100		100		200	
Material	Material of knurl		Zinc die-cast (Nickel plating)				
	Contact (Surface treatment)		CuSn (Au plating (Ni underplating))		CuSn (Au plating (Ni underplating))		
	Connector material		TPU (UL94 HB)		PA66 (UL94 V0)		TPU (UL94 HB)
	Material of sheath (Sheath color)		PUR (Purple (RAL 4001 equivalent))		—		
Weight		Approx. 308 g	Approx. 306 g	Approx. 37 g	Approx. 42 g	Approx. 12 g	

*1 The shaded sections show the specifications for the applicable cable. Adaptation for the connector may vary on account of the conductor construction of the electric wire.

*2 Can also be used for CANopen communication

Specifications

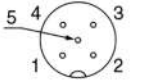
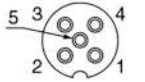
Description		Communication cable (With straight connector on both sides)	Communication cable (With angle connector on both sides)	
Part no. (Cable length)		EX9-AC005DN-SSPS (0.5 m) EX9-AC010DN-SSPS (1 m) EX9-AC020DN-SSPS (2 m) EX9-AC030DN-SSPS (3 m) EX9-AC050DN-SSPS (5 m) EX9-AC100DN-SSPS (10 m)	EX9-AC005DN-SAPA (0.5 m) EX9-AC010DN-SAPA (1 m) EX9-AC020DN-SAPA (2 m) EX9-AC030DN-SAPA (3 m) EX9-AC050DN-SAPA (5 m) EX9-AC100DN-SAPA (10 m)	
Product image				
Number of functional poles		M12: 5 pins		
Key type		A-coded (Normal key)		
Pin assignment		 <p>Plug, A-coded (Viewed from the plug/socket side)</p>	 <p>Socket, A-coded</p>	DeviceNet® / CANopen 1: DRAIN 1: — 2: V+ (Red) 2: — 3: V- (Black) 3: CAN GND 4: CAN H (White) 4: CAN H 5: CAN L (Blue) 5: CAN L
Wiring	Fixed cable length	0.5 m, 1 m, 2 m, 3 m, 5 m, 10 m		
	Cable O.D.	6.7 mm		
	Conductor nominal cross section	Power pair	0.34 mm ² /AWG22	
		Data pair	0.25 mm ² /AWG24	
	Wire O.D. (Including insulating material)	Power pair	1.4 mm	
Data pair		1.95 mm		
Rating/Performance	Rated current	4 A		
	Rated voltage	48 VAC/60 VDC		
	Contact resistance	10 mΩ or less		
	Insulation resistance	100 MΩ or more		
	Withstand voltage	1.0 kV		
	Ambient temperature	-20 to +80°C		
	Min. bending radius (Fixed)	67 mm		
	Protection class	IP67 (Only with screw tightened)		
	Allowable repeated insertion/withdrawal	100		
Material	Material of knurl	Zinc die-cast (Nickel plating)		
	Contact (Surface treatment)	CuSn (Au plating (Ni underplating))		
	Connector material	TPU (UL94 HB)		
	Material of sheath (Sheath color)	PUR (Purple (RAL 4001 equivalent))		
Weight		0.5 m: Approx. 75 g 1 m: Approx. 105 g 2 m: Approx. 165 g 3 m: Approx. 225 g 5 m: Approx. 345 g 10 m: Approx. 645 g	0.5 m: Approx. 75 g 1 m: Approx. 105 g 2 m: Approx. 165 g 3 m: Approx. 225 g 5 m: Approx. 345 g 10 m: Approx. 645 g	

Communication Cable/Connector



M12



Example of Connection

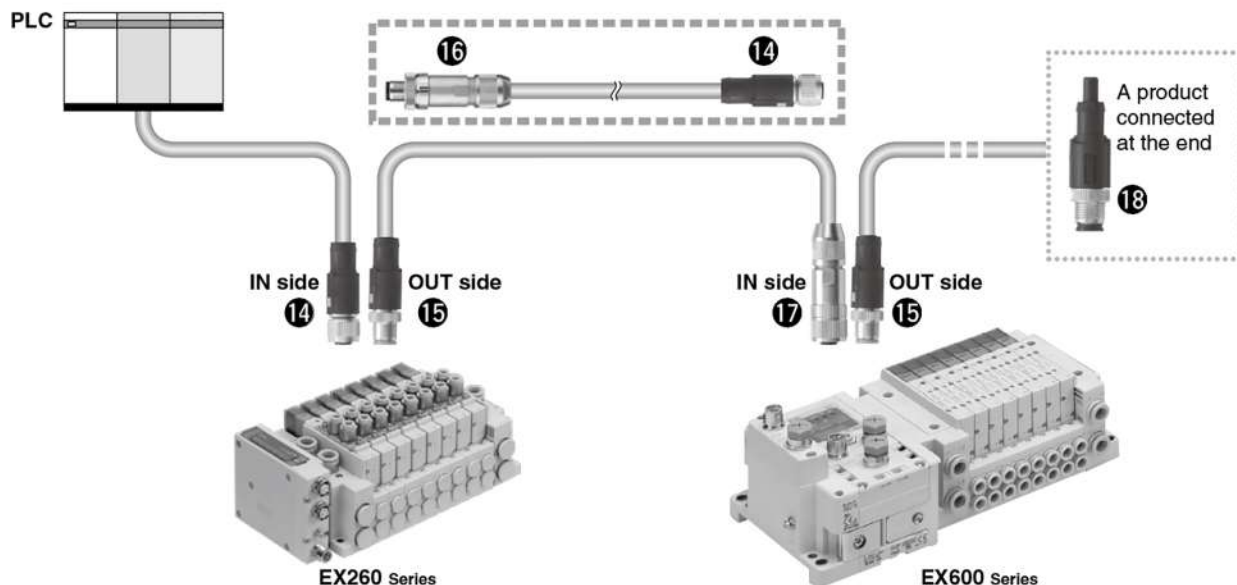

Specifications

Description		Communication cable (With connector on one side)		Field-wireable connector		Terminal resistor	
Part no.		PCA-1557688	PCA-1557691	PCA-1075530	PCA-1075531	PCA-1557727	
Product image							
		Socket	Plug	Plug	Socket	For PROFIBUS DP (Plug, B-coded)	
Number of functional poles		M12: 2 pins		M12: 3 pins		M12: 4 pins	
Key type		B-coded (Reverse key)					
Pin assignment				1: — 2: A Line (Green) 3: — 4: B Line (Red) 5: —		1: VP 4: B Line 2: A Line 3: DGND	
		Plug, B-coded (Viewed from the plug/socket side)					
Wiring	Fixed cable length	5 m		—			
	Cable O.D.	7.8 mm		Applicable cable*1	4.0 to 8.0 mm		
	Conductor nominal cross section	0.34 mm ² /AWG22			0.14 to 0.75 mm ² /AWG26 to 18 (Solid cable/Flexible cable) 0.08 to 0.5 mm ² /AWG28 to 20 (With ferrule)		
	Wire O.D. (Including insulating material)	2.55 mm		—			
Connection type	—		Push-in type				
Rating/Performance	Rated current	4 A					
	Rated voltage	60 V		48 VAC/60 VAC		60 V	
	Contact resistance	5 mΩ or less		10 mΩ or less		5 mΩ or less	
	Insulation resistance	100 MΩ or more					
	Withstand voltage	1.4 kV					
	Ambient temperature	Connector	-25 to +90°C		-40 to +85°C		-25 to +90°C
		Cable	-40 to +85°C		—		
	Min. bending radius (Fixed)	78 mm		—			
Protection class	IP67 (Only with screw tightened)						
Allowable repeated insertion/withdrawal	200						
Material	Material of knurl	Zinc die-cast (Nickel plating)					
	Contact (Surface treatment)	CuSn (Au plating (Ni underplating))					
	Connector material	TPU/PA66 (UL94 HB)		PA66 (UL94 V0)		TPU/PA66 (UL94 HB)	
	Material of sheath (Sheath color)	PUR (Purple (RAL 4001 equivalent))		—			
Weight	Approx. 343 g	Approx. 356 g	Approx. 37 g	Approx. 42 g	Approx. 12 g		

*1 The shaded sections show the specifications for the applicable cable. Adaptation for the connector may vary on account of the conductor construction of the electric wire.

Communication Cable

For EtherNet/IP™ For PROFINET For EtherCAT For Ethernet POWERLINK

① EX9-AC 020 EN-PSRJ (Plug/RJ-45 connector)

• Cable length (L)

010	1000 mm
020	2000 mm
030	3000 mm
050	5000 mm
100	10000 mm

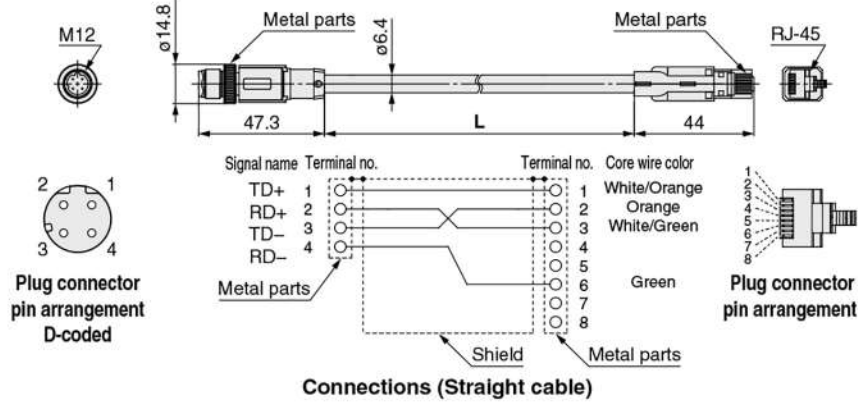

② PCA-1446566 (Plug)

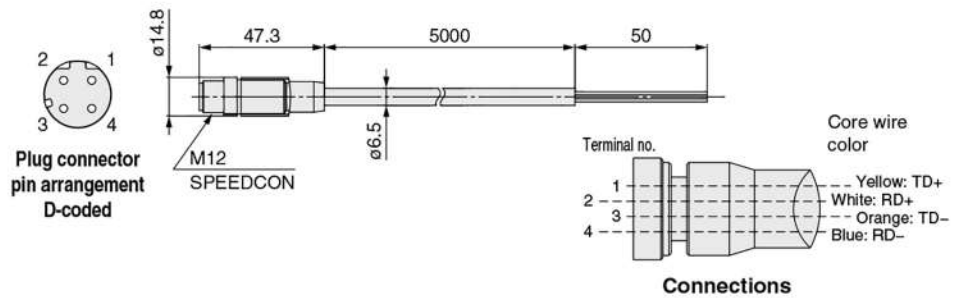

EX9-AC 005 EN-PSPS (With connector on both sides (Plug/Plug))

• Cable length (L)

005	500 mm
010	1000 mm
020	2000 mm
030	3000 mm
050	5000 mm
100	10000 mm

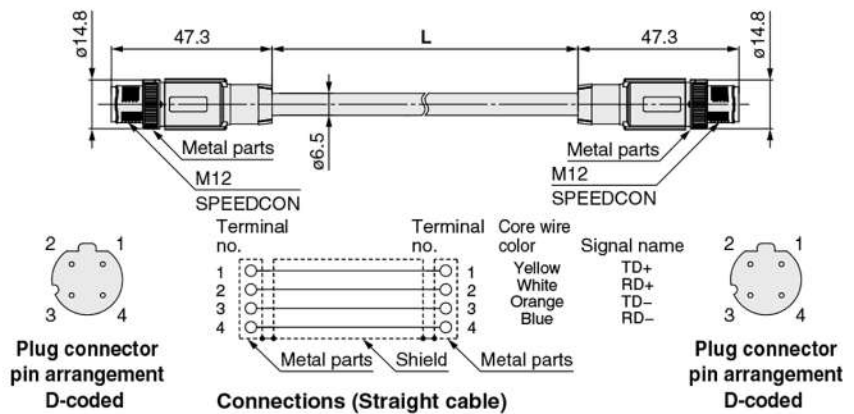

EX9-AC 005 EN-PAPA (With angle connector on both sides (Plug/Plug))

• Cable length (L)

005	500 mm
010	1000 mm
020	2000 mm
030	3000 mm
050	5000 mm
100	10000 mm

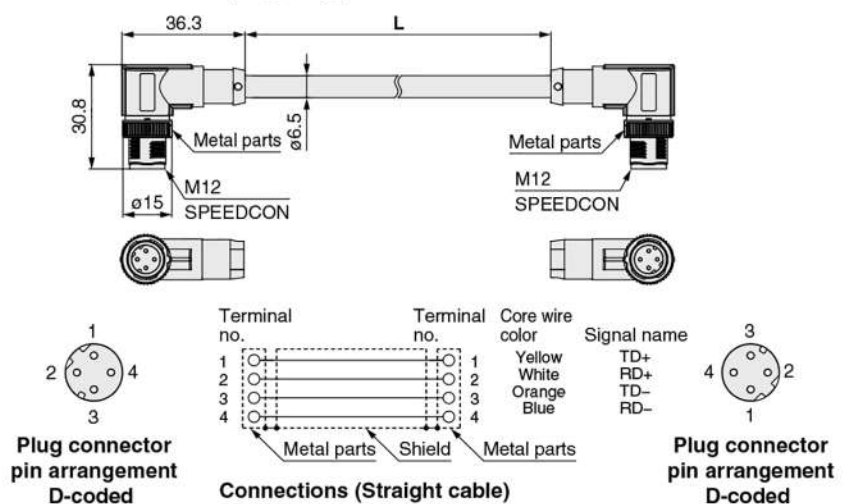

Communication Cable/Connector

Communication Cable

For CC-Link

④ PCA-1567720
(Socket)



Made to Order

Change in the cable length

p. 1538

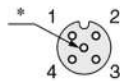

Socket connector pin arrangement
A-coded (Normal key)

* Number of holes: 5,
Total number of pins: 4

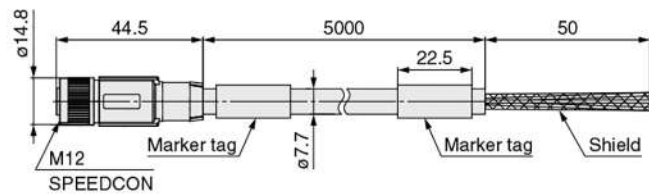

⑤ PCA-1567717
(Plug)

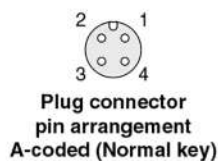

Plug connector pin arrangement
A-coded (Normal key)

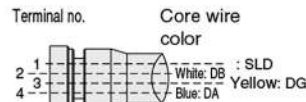
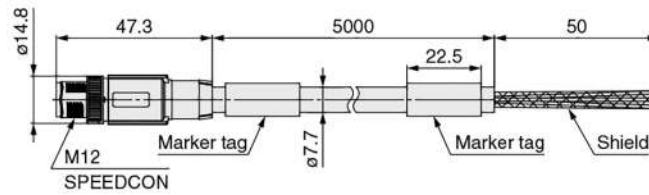

Connections

EX9-AC 005 MJ-SSPS (With connector on both sides (Socket/Plug))

● Cable length (L)

005	500 mm
010	1000 mm
020	2000 mm
030	3000 mm
050	5000 mm
100	10000 mm

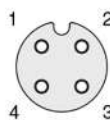
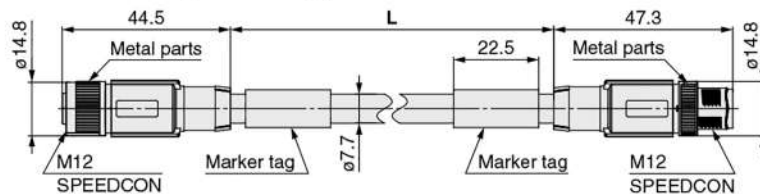

Socket connector pin arrangement
A-coded (Normal key)

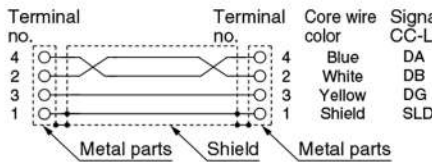

Connections

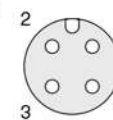

Plug connector pin arrangement
A-coded (Normal key)

EX9-AC 005 MJ-SAPA (With angle connector on both sides (Socket/Plug))

● Cable length (L)

005	500 mm
010	1000 mm
020	2000 mm
030	3000 mm
050	5000 mm
100	10000 mm

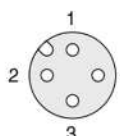
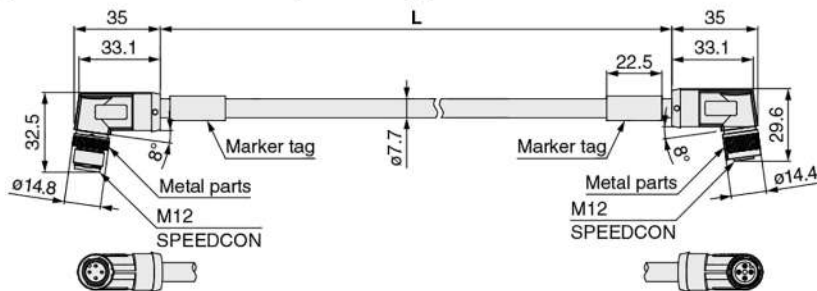

Plug connector pin arrangement
A-coded (Normal key)

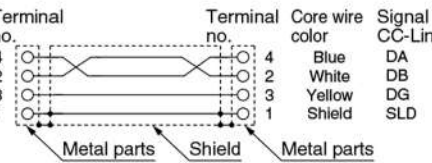

Connections

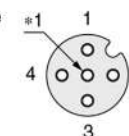

Socket connector pin arrangement
A-coded (Normal key)

*1 Number of holes: 5, Total number of pins: 4

Communication Cable

For DeviceNet®

8 PCA-1557633
(Socket)



Made to Order

Change in the cable length p. 1538

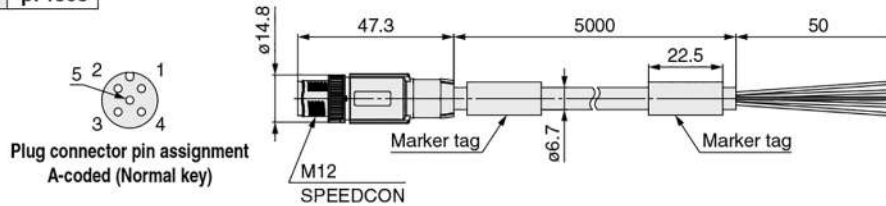
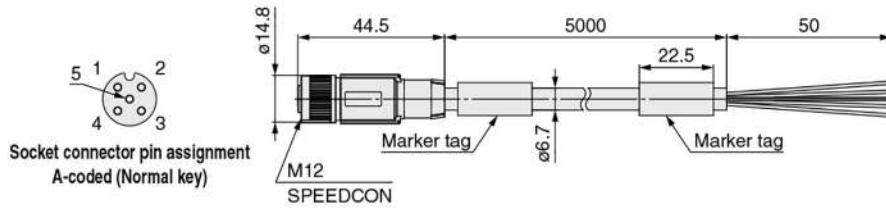

9 PCA-1557646
(Plug)

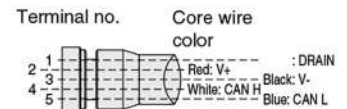

EX9-AC 005 DN-SSPS (With connector on both sides (Socket/Plug))

• Cable length (L)

005	500 mm
010	1000 mm
020	2000 mm
030	3000 mm
050	5000 mm
100	10000 mm

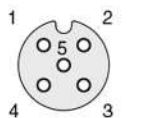
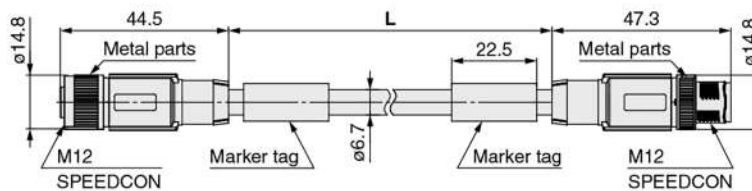

Socket connector pin arrangement
A-coded (Normal key)

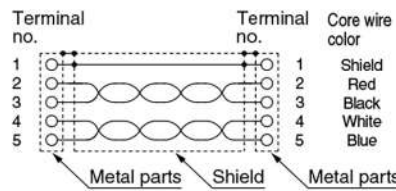

Connections

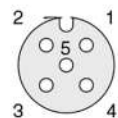

Plug connector pin arrangement
A-coded (Normal key)

EX9-AC 005 DN-SAPA (With angle connector on both sides (Socket/Plug))

• Cable length (L)

005	500 mm
010	1000 mm
020	2000 mm
030	3000 mm
050	5000 mm
100	10000 mm

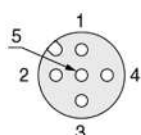
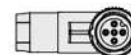
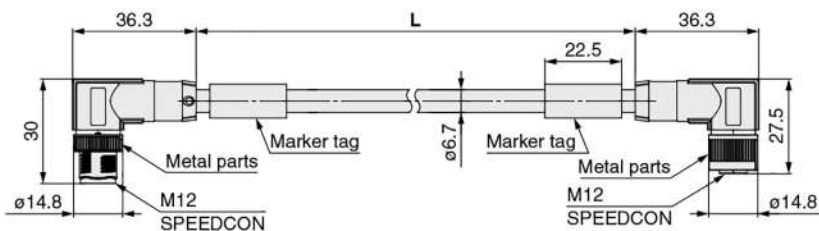

Plug connector pin arrangement
A-coded (Normal key)

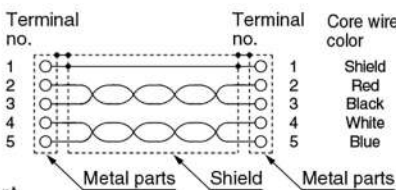

Connections

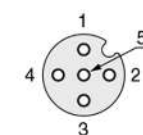

Socket connector pin arrangement
A-coded (Normal key)

Communication Cable/Connector

Communication Cable

For PROFIBUS DP

⑭ PCA-1557688
(Socket)

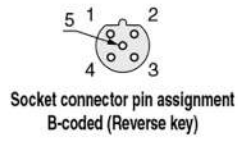

⑮ PCA-1557691
(Plug)

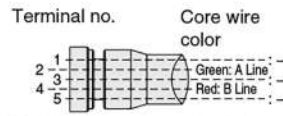
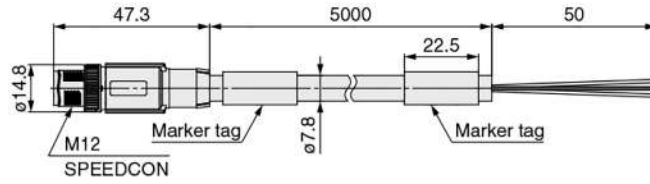
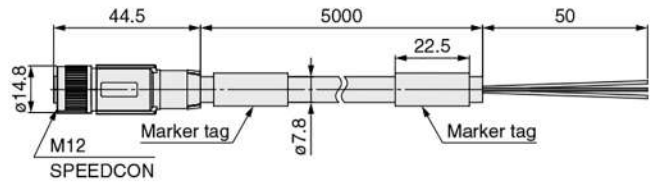
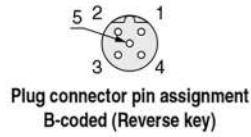

Connections

Field-wireable Communication Connector

Plug

For EtherNet/IP™ For PROFINET For EtherCAT

③ PCA-1446553

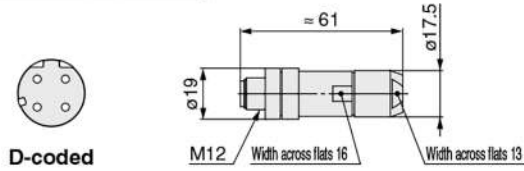

D-coded

Applicable Cable

Item	Specifications
Cable O.D.	4.0 to 8.0 mm
Wire gauge (Stranded wire cross section)	0.14 to 0.34 mm ² /AWG26 to 22

* The table above shows the specifications for the applicable cable. Adaptation for the connector may vary on account of the conductor construction of the electric wire.

For CC-Link For DeviceNet®

⑥ PCA-1075526 ⑪ PCA-1075528

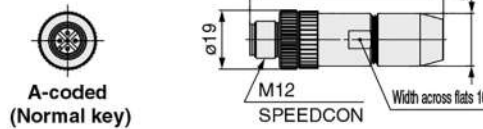

A-coded
(Normal key)

For PROFIBUS DP

⑬ PCA-1075530

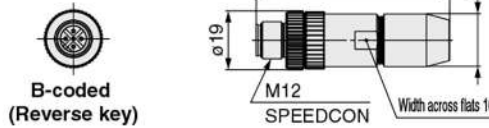

B-coded
(Reverse key)

Applicable Cable

Item	Specifications
Cable O.D.	4.0 to 8.0 mm
Wire gauge (Stranded wire cross section)	0.14 to 0.75 mm ² /AWG26 to 18 (Solid cable/Flexible cable) 0.08 to 0.5 mm ² /AWG28 to 20 (With ferrule)

Socket

For CC-Link For DeviceNet®

⑦ PCA-1075527 ⑫ PCA-1075529

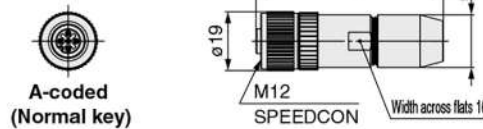

A-coded
(Normal key)

For PROFIBUS DP

⑭ PCA-1075531

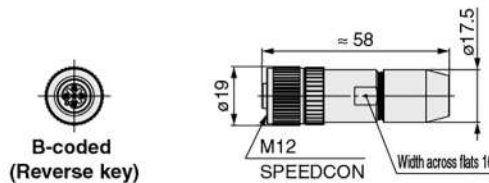

B-coded
(Reverse key)

Applicable Cable

Item	Specifications
Cable O.D.	4.0 to 8.0 mm
Wire gauge (Stranded wire cross section)	0.14 to 0.75 mm ² /AWG26 to 18 (Solid cable/Flexible cable) 0.08 to 0.5 mm ² /AWG28 to 20 (With ferrule)

Terminating Resistor

For DeviceNet®

⑬ PCA-1557675
Terminating resistor for DeviceNet®

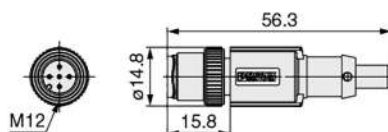

For PROFIBUS DP

⑬ PCA-1557727
Terminating resistor for PROFIBUS DP

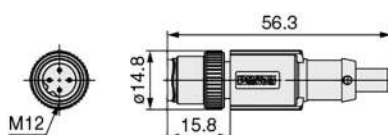

Power Supply Cable/Connector

EX600 Series

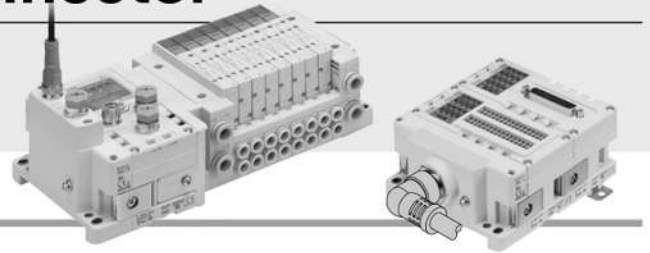

Specifications

Description		Power supply cable (With connector on one side)				Field-wireable connector		
		19	20	21	22	23 PCA-1578081		
Part no. (Cable length)		PCA-1564927 (2 m) PCA-1564930 (6 m)	PCA-1564943 (2 m) PCA-1564969 (6 m)	PCA-1558810 (2 m) PCA-1558823 (6 m)	PCA-1558836 (2 m) PCA-1558849 (6 m)			
Protocol		EtherNet/IP™, PROFINET, EtherCAT, PROFIBUS DP, DeviceNet®, CC-Link						
Number of functional poles		M12: 5 pins			7/8 inch: 5 pins			
Key type		B-coded			—			
Wiring	Cable O.D.	5.9 mm			12.58 mm		12.0 to 14.0 mm	
	Conductor nominal cross section	AWG22			AWG16		0.34 to 1.5 mm ² /AWG22 to 16	
	Wire O.D. (Including insulating material)	1.27 mm			2.35 mm		—	
Connection type		—			Screw tightening			
Rating/Performance	Rated current	4 A			8 A		9 A	
	Rated voltage	60 V			600 V		250 V	
	Contact resistance	5 mΩ or less						
	Insulation resistance	100 MΩ or more						
	Withstand voltage	1.0 kV			1.4 kV		4 kV	
	Ambient temperature	Connector	-25 to +90°C			-25 to +80°C		-25 to +85°C
		Cable	-25 to +80°C			-10 to +105°C		—
	Min. bending radius (Fixed)	59 mm			110 mm		—	
Protection class	IP67 (Only with screw tightened)							
Allowable repeated insertion/withdrawal	200			100		50		
Material	Material of knurl	Zinc die-cast (Nickel plating)			Brass (Nickel plating)		Zinc die-cast (Nickel plating)	
	Contact (Surface treatment)	CuSn (Au plating (Ni underplating))						
	Connector material	TPU (UL94 HB)			PUR (UL94 HB)		PUR/PA66/PBT (UL94 HB)	
	Material of sheath (Sheath color)	PUR (Black-Gray (RAL 7021 equivalent))			PVC (Yellow (RAL 1021 equivalent))		—	
Weight		2 m: Approx. 113 g 6 m: Approx. 425 g	2 m: Approx. 130 g 6 m: Approx. 475 g	2 m: Approx. 446 g 6 m: Approx. 1270 g	2 m: Approx. 455 g 6 m: Approx. 1300 g	Approx. 47.6 g		

*1 The shaded sections show the specifications for the applicable cable. Adaptation for the connector may vary on account of the conductor construction of the electric wire.

Power Supply Cable/Connector

19 20 PCA-1564927

Socket specification, Cable length (L)

1564927	Straight 2 m
1564930	Straight 6 m
1564943	Angle 2 m
1564969	Angle 6 m

Item	Specifications
Cable O.D.	ø5.9 mm
Conductor nominal cross section	0.34 mm ² /AWG22
Wire O.D. (Including insulator)	1.27 mm
Min. bending radius (Fixed)	59 mm

Straight connector type

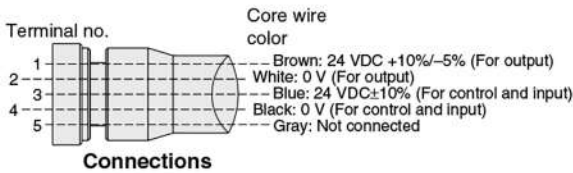
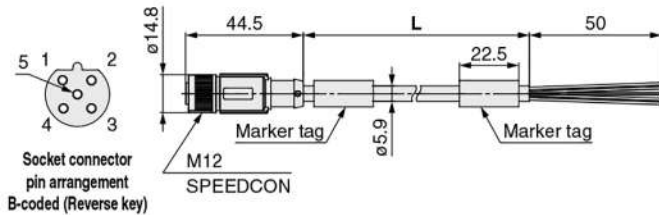

Angle connector type

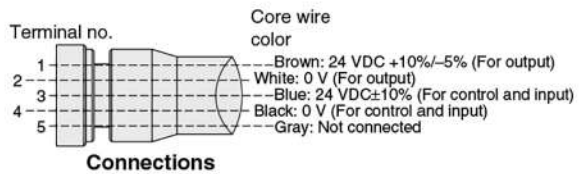
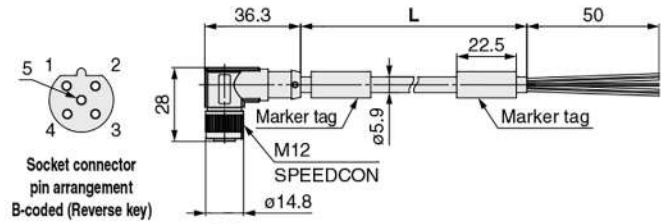

21 22 PCA-1558810

Socket specification, Cable length (L)

1558810	Straight 2 m
1558823	Straight 6 m
1558836	Angle 2 m
1558849	Angle 6 m

Item	Specifications
Cable O.D.	ø12.58 mm
Conductor nominal cross section	1.5 mm ² /AWG16
Wire O.D. (Including insulator)	2.35 mm
Min. bending radius (Fixed)	110 mm

Straight connector type

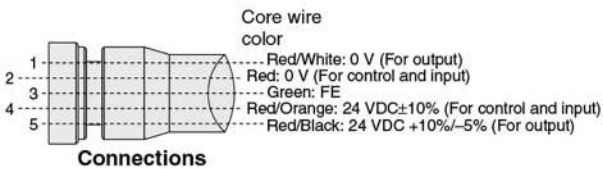
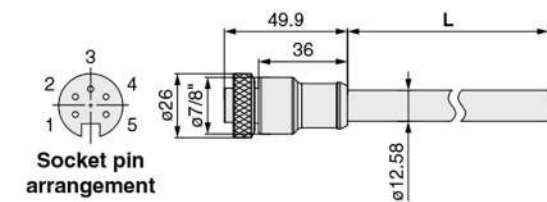

Angle connector type

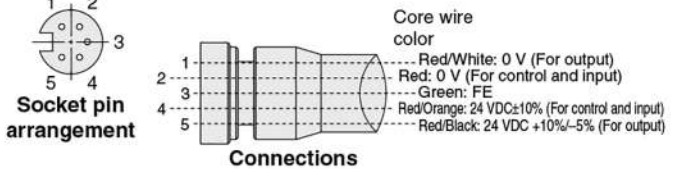
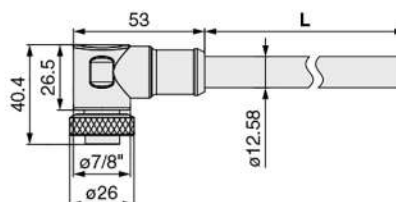

Socket

23 PCA-1578081

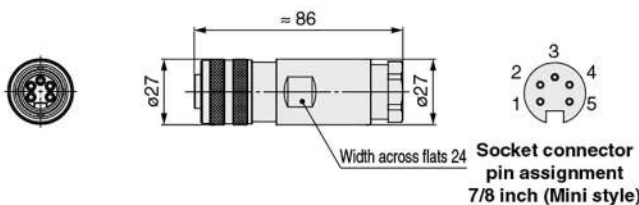

Power Supply Cable/Connector

EX500 Series

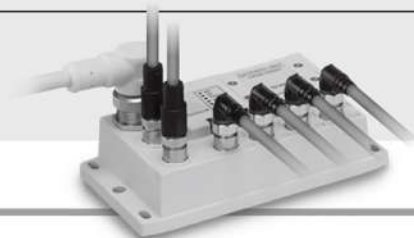

Specifications/Gateway Decentralized System 2 (128 Points)

Description		Power supply cable (With connector on one side)				
Part no. (Cable length)		24 PCA-1415999 (2 m) PCA-1415996 (6 m)	25 PCA-1416000 (2 m) PCA-1415997 (6 m)	21 PCA-1558810 (2 m) PCA-1558823 (6 m)	22 PCA-1558836 (2 m) PCA-1558849 (6 m)	
Protocol		EtherNet/IP™		PROFINET		
Number of functional poles		7/8 inch: 4 pins		7/8 inch: 5 pins		
Key type		—				
Wiring	Cable O.D.	10.7 mm		12.58 mm		
	Conductor nominal cross section	1.5 mm ² /AWG16		1.5 mm ² /AWG16		
	Wire O.D. (Including insulating material)	2.35 mm		2.35 mm		
Rating/Performance	Rated current	10 A		8 A		
	Rated voltage	600 V		600 V		
	Contact resistance	5 mΩ or less				
	Insulation resistance	100 MΩ or more				
	Withstand voltage	1.4 kV				
	Ambient temperature	Connector	-25 to 80°C			
		Cable	-30 to +105°C		-10 to +105°C	
	Min. bending radius (Fixed)	94 mm		110 mm		
	Protection class	IP67 (Only with screw tightened)				
	Allowable repeated insertion/withdrawal	100				
Material	Material of knurl	Brass (Nickel plating)		Brass (Nickel plating)		
	Contact (Surface treatment)	CuSn (Au plating)				
	Connector material	PUR (UL94 HB)				
	Material of sheath (Sheath color)	PVC (Yellow (RAL 1021 equivalent))				
Weight		2 m: Approx. 385 g 6 m: Approx. 1065 g	2 m: Approx. 395 g 6 m: Approx. 1075 g	2 m: Approx. 446 g 6 m: Approx. 475 g	2 m: Approx. 455 g 6 m: Approx. 1300 g	

Specifications/Gateway Decentralized System (64 Points)



Description		Power supply cable (With connector on one side)		
Part no. (Cable length)		26 EX500-AP010-S (1 m) EX500-AP050-S (5 m)	27 EX500-AP010-A (1 m) EX500-AP050-A (5 m)	
Protocol		PROFIBUS DP		
Number of functional poles		M12: 5 pins		
Key type		A-coded		
Wiring	Cable O.D.	6 mm		
	Conductor nominal cross section	0.3 mm ² /AWG22		
	Wire O.D. (Including insulating material)	1.5 mm		
Rating/Performance	Rated current	3 A		
	Rated voltage	125 V		
	Contact resistance	40 mΩ or less		
	Insulation resistance	1000 MΩ or more		
	Withstand voltage	1.5 kV		
	Ambient temperature	Connector	-25 to +60°C	
		Cable	-25 to +60°C	
	Min. bending radius (Fixed)	40 mm		
	Protection class	IP67 (Only with screw tightened)		
	Allowable repeated insertion/withdrawal	200		
Material	Material of knurl	Brass (Nickel plating)		
	Contact (Surface treatment)	Phosphor bronze (Au plating)		
	Connector material	Soft PBT (UL94 V0)		
	Material of sheath (Sheath color)	PVC (Light gray)		
Weight		1 m: Approx. 80 g 5 m: Approx. 395 g	1 m: Approx. 85 g 5 m: Approx. 400 g	

Power Supply Cable/Gateway Decentralized System 2 (128 Points)

For EtherNet/IP™

②④ PCA-1416000

Connector specification, Cable length (L)

1415999	Straight 2 m
1415996	Straight 6 m
1416000	Angle 2 m
1415997	Angle 6 m

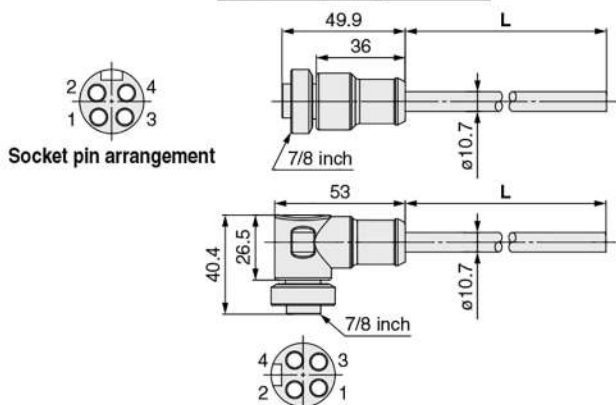

Socket pin arrangement

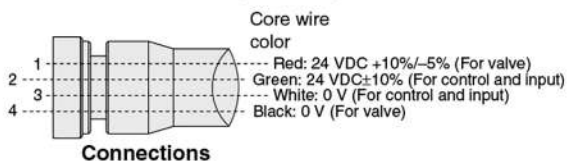

Connections

Item	Specifications
Cable O.D.	ø10.7 mm
Conductor nominal cross section	1.5 mm ² /AWG16
Min. bending radius (Fixed)	94 mm

For PROFINET

②① PCA-1558810

Connector specification, Cable length (L)

1558810	Straight 2 m
1558823	Straight 6 m
1558836	Angle 2 m
1558849	Angle 6 m

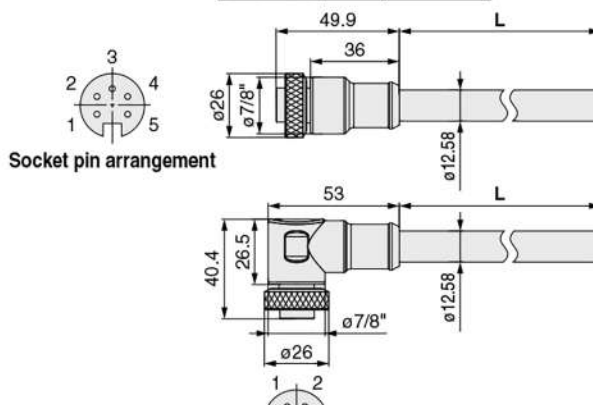

Socket pin arrangement

Socket pin arrangement

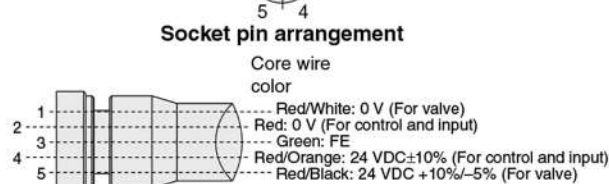

Connections

Item	Specifications
Cable O.D.	ø12.58 mm
Conductor nominal cross section	1.5 mm ² /AWG16
Wire O.D. (Including insulator)	2.35 mm
Min. bending radius (Fixed)	110 mm

Power Supply Cable/Gateway Decentralized System (64 Points)

For PROFIBUS DP

②⑥ EX500-AP 050 - S

Cable length (L)

010	1000 mm
050	5000 mm

Connector specification

S	Straight
A	Angle

Straight connector type

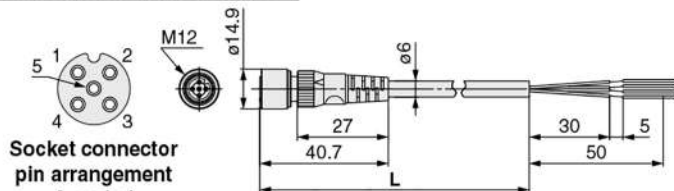

Socket connector pin arrangement A-coded (Normal key)

Item	Specifications
Cable O.D.	ø6 mm
Conductor nominal cross section	0.3 mm ² /AWG22
Wire O.D. (Including insulator)	1.5 mm
Min. bending radius (Fixed)	40 mm

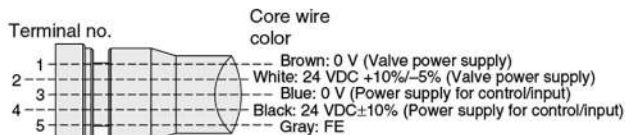

Connections (PROFIBUS DP)

Angle connector type

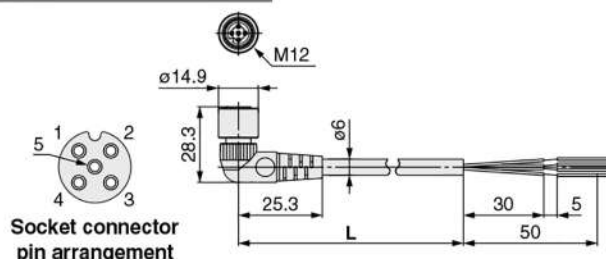

Socket connector pin arrangement A-coded (Normal key)

Item	Specifications
Cable O.D.	ø6 mm
Conductor nominal cross section	0.3 mm ² /AWG22
Wire O.D. (Including insulator)	1.5 mm
Min. bending radius (Fixed)	40 mm



Made to Order

Cable length	10000 mm	p. 1539
--------------	----------	---------

Power Supply Cable/Connector

EX260 Series

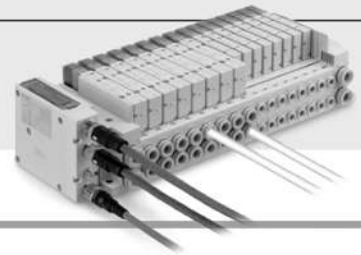

Specifications

Description		Power supply cable (With connector on one side)				
Part no. (Cable length)	26 EX500-AP010-S (1 m) EX500-AP050-S (5 m)	27 EX500-AP010-A (1 m) EX500-AP050-A (5 m)	28 PCA-1401804 (1.5 m) PCA-1401805 (3 m) PCA-1401806 (5 m)	29 EX9-AC010-1 (1 m) EX9-AC030-1 (3 m) EX9-AC050-1 (5 m)	30 PCA-1401807 (1.5 m) PCA-1401808 (3 m) PCA-1401809 (5 m)	
Protocol	PROFIBUS DP, DeviceNet®, EtherCAT, PROFINET, EtherNet/IP™			CC-Link		
Number of functional poles	M12: 5 pins					
Key type	A-coded		B-coded			
Wiring	Cable O.D.	6 mm	5 mm	6.6 mm	5 mm	
	Conductor nominal cross section	0.3 mm ² /AWG22	AWG22	0.3 mm ² /AWG22	AWG22	
	Wire O.D. (Including insulating material)	1.5 mm	1.27 mm	1.65 mm	1.27 mm	
Rating/Performance	Rated current	3 A	4 A	3.1 A	4 A	
	Rated voltage	125 V	60 V	125 V	60 V	
	Contact resistance	40 mΩ or less	5 mΩ or less	40 mΩ or less	5 mΩ or less	
	Insulation resistance	1000 MΩ or more	100 MΩ or more	1000 MΩ or more	100 MΩ or more	
	Withstand voltage	1.5 kV	1.0 kV	1.5 kV	1.0 kV	
	Ambient temperature	Connector	-25 to +60°C	-40 to +80°C	-25 to +60°C	-40 to +80°C
		Cable	-25 to +60°C	-40 to +80°C	-25 to +60°C	-40 to +80°C
	Min. bending radius (Fixed)	40 mm	21.7 mm	40 mm	21.7 mm	
	Protection class	IP67 (Only with screw tightened)				
	Allowable repeated insertion/withdrawal	200				
Material	Material of knurl	Brass (Nickel plating)	Zinc die-cast (Nickel plating)	Brass (Nickel plating)	Zinc die-cast (Nickel plating)	
	Contact (Surface treatment)	Phosphor bronze (Au plating)	CuSn (Au plating)	Phosphor bronze (Au plating)	CuSn (Au plating)	
	Connector material	Soft PBT (UL94 V0)	TPU (UL94 HB)	Soft PBT (UL94 V0)	TPU (UL94 HB)	
	Material of sheath (Sheath color)	PVC (Light gray)	PUR (Black-Gray (RAL 7021 equiv.))	PVC (Light gray)	PUR (Black-Gray (RAL 7021 equiv.))	
Weight	1 m: Approx. 80 g 5 m: Approx. 395 g	1 m: Approx. 85 g 5 m: Approx. 400 g	1.5 m: Approx. 65 g 3 m: Approx. 130 g 5 m: Approx. 195 g	1 m: Approx. 85 g 3 m: Approx. 215 g 5 m: Approx. 345 g	1.5 m: Approx. 65 g 3 m: Approx. 130 g 5 m: Approx. 195 g	

Power Supply Cable

For PROFIBUS DP For DeviceNet® For EtherCAT For PROFINET For EtherNet/IP™

26 27 EX500-AP 050 - S

Cable length (L)

010	1000 mm
050	5000 mm

Connector specification

S	Straight
A	Angle

Straight connector type

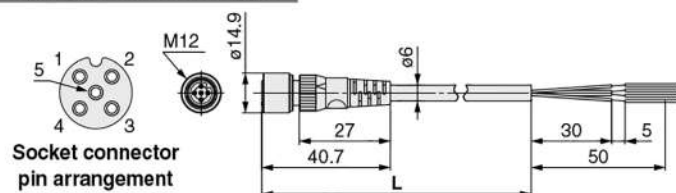

Socket connector pin arrangement A-coded (Normal key)

Item	Specifications
Cable O.D.	ø6 mm
Conductor nominal cross section	0.3 mm ² /AWG22
Wire O.D. (Including insulator)	1.5 mm
Min. bending radius (Fixed)	40 mm

Terminal no.



Connections (PROFIBUS DP/EtherCAT/PROFINET)

Angle connector type

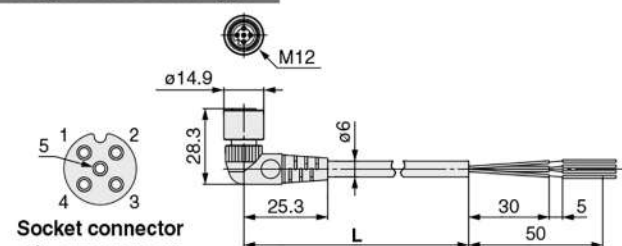

Socket connector pin arrangement A-coded (Normal key)

Item	Specifications
Cable O.D.	ø6 mm
Conductor nominal cross section	0.3 mm ² /AWG22
Wire O.D. (Including insulator)	1.5 mm
Min. bending radius (Fixed)	40 mm

Terminal no.

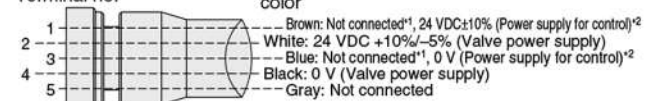

Connections (DeviceNet®, EtherNet/IP™)

*1 For DeviceNet®
*2 For EtherNet/IP™



Made to Order

Cable length	10000 mm	p. 1539
--------------	----------	---------

Power Supply Cable

For PROFIBUS DP For DeviceNet® For EtherCAT For PROFINET For EtherNet/IP™

28 PCA-1401804

• Cable length (L)

1401804	1500 mm
1401805	3000 mm
1401806	5000 mm

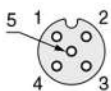

Socket connector pin arrangement
A-coded
(Normal key)

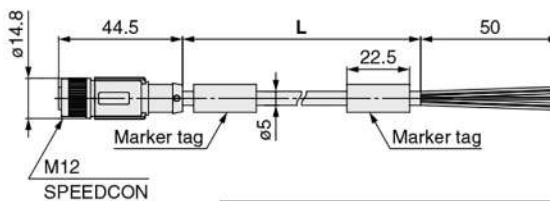

Item	Specifications
Cable O.D.	ø5 mm
Conductor nominal cross section	0.34 mm ² /AWG22
Wire O.D. (Including insulator)	1.27 mm
Min. bending radius (Fixed)	21.7 mm

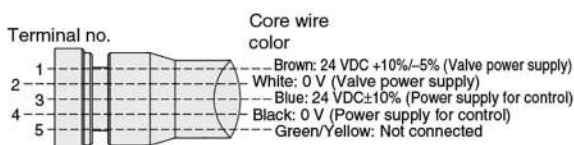

Connections (PROFIBUS DP/EtherCAT/PROFINET)

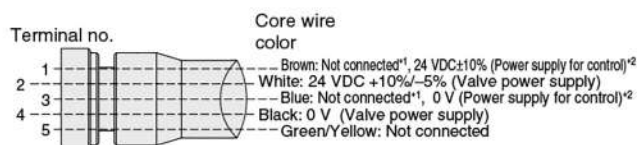

Connections (DeviceNet®, EtherNet/IP™)

*1 For DeviceNet®
*2 For EtherNet/IP™

For CC-Link

Straight connector type

29 EX9-AC 050 -1

• Cable length (L)

010	1000 mm
030	3000 mm
050	5000 mm

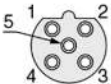

Socket connector pin arrangement
B-coded
(Reverse key)

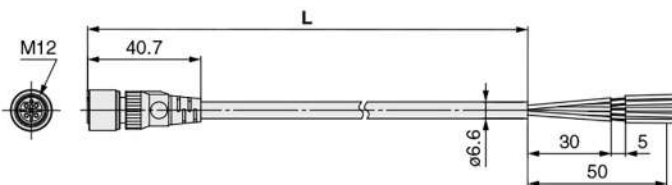

Item	Specifications
Cable O.D.	ø6.6 mm
Conductor nominal cross section	0.3 mm ² /AWG22
Wire O.D. (Including insulator)	1.65 mm
Min. bending radius (Fixed)	40 mm

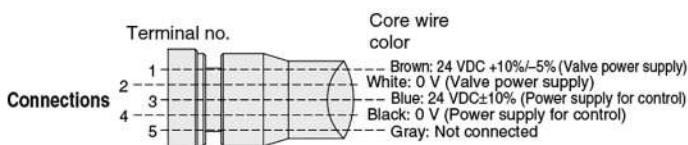

Connections



Made to Order

Cable length	10000 mm	p. 1539
--------------	----------	---------

30 PCA-1401807

• Cable length (L)

1401807	1500 mm
1401808	3000 mm
1401809	5000 mm

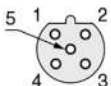

Socket connector pin arrangement
B-coded
(Reverse key)

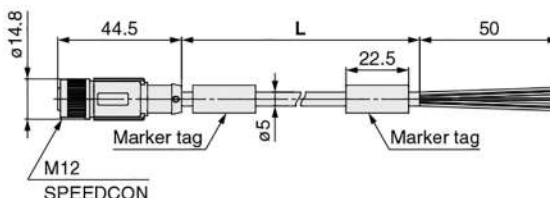

Item	Specifications
Cable O.D.	ø5 mm
Conductor nominal cross section	0.34 mm ² /AWG22
Wire O.D. (Including insulator)	1.27 mm
Min. bending radius (Fixed)	21.7 mm

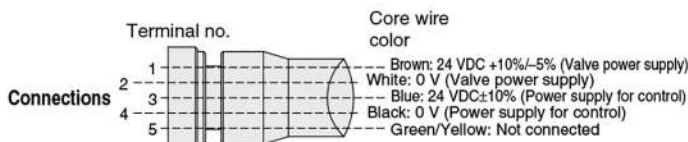

Connections

Power Supply Cable

EX250 Series



Specifications

Description		Power supply cable (With connector on one side)		
Part no. (Cable length)		29 EX9-AC010-1 (1 m) EX9-AC030-1 (3 m) EX9-AC050-1 (5 m)	26 EX500-AP010-S (1 m) EX500-AP050-S (5 m)	
Protocol		CC-Link, DeviceNet®	EtherNet/IP™	
Number of functional poles		M12: 5 pins	M12: 5 pins	
Key type		B-coded	A-coded	
Wiring	Cable O.D.	6.6 mm	6 mm	
	Conductor nominal cross section	0.3 mm ² /AWG22	0.3 mm ² /AWG22	
	Wire O.D. (Including insulating material)	1.65 mm	1.5 mm	
Rating/Performance	Rated current	3.1 A	3 A	
	Rated voltage	125 V		
	Contact resistance	40 mΩ or less		
	Insulation resistance	1000 MΩ or more		
	Withstand voltage	1.5 kV		
	Ambient temperature	Connector	-25 to +60°C	
		Cable	-25 to +60°C	
	Min. bending radius (Fixed)	40 mm		
	Protection class	IP67 (Only with screw tightened)		
	Allowable repeated insertion/withdrawal	200		
Material	Material of knurl	Brass (Nickel plating)		
	Contact (Surface treatment)	Phosphor bronze (Au plating)		
	Connector material	Soft PBT (UL94 V0)		
	Material of sheath (Sheath color)	PVC (Light gray)		
Weight		1 m: Approx. 85 g 3 m: Approx. 215 g 5 m: Approx. 345 g	1 m: Approx. 80 g 5 m: Approx. 395 g	

Power Supply Cable

For CC-Link For DeviceNet®

Straight connector type

29 EX9-AC 050 -1

Cable length (L)

010	1000 mm
030	3000 mm
050	5000 mm

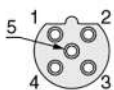

Socket connector pin arrangement
B-coded
(Reverse key)

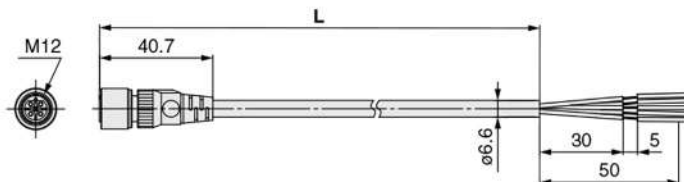

Item	Specifications
Cable O.D.	ø6.6 mm
Conductor nominal cross section	0.3 mm ² /AWG22
Wire O.D. (including insulator)	1.65 mm
Min. bending radius (Fixed)	40 mm



Made to Order

Cable length	10000 mm	p. 1539
--------------	----------	---------

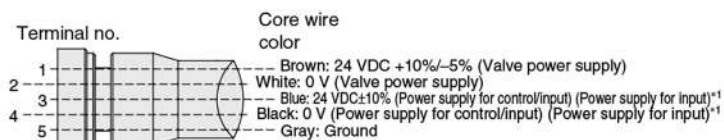

Connections

*1 For DeviceNet®

For EtherNet/IP™

Straight connector type

26 EX500-AP 050 -S

Cable length (L)

010	1000 mm
050	5000 mm

Connector specification

S	Straight
---	----------

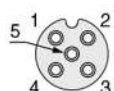

Socket connector pin arrangement
A-coded
(Normal key)

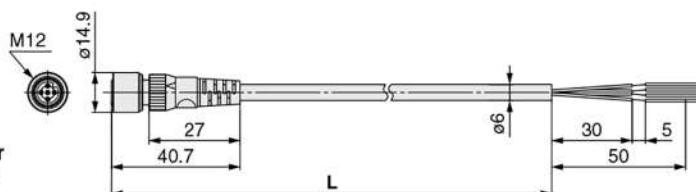

Item	Specifications
Cable O.D.	ø6 mm
Conductor nominal cross section	0.3 mm ² /AWG22
Wire O.D. (including insulator)	1.5 mm
Min. bending radius (Fixed)	40 mm



Made to Order

Cable length	10000 mm	p. 1539
--------------	----------	---------

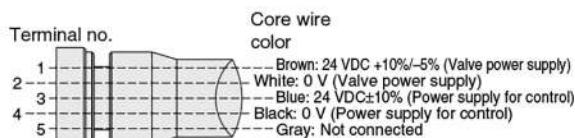



Connections

Accessory Between the Sensor/Switch and the Input Device

Field-wireable Connector

Specifications

Part no.	PCA-1557730	PCA-1557743	PCA-1557756	
Product image/Pin assignment				
Number of functional poles	M8: 3 poles	M12: 4 poles		
Key type	—	A-coded (Normal key)		
Wiring*1	Cable O.D.	3.0 to 5.0 mm	3.5 to 6.0 mm	4.0 to 8.0 mm
	Wire gauge (Stranded wire cross section)	0.14 to 0.25 mm ² /AWG26 to 24 0.25 to 0.34 mm ² /AWG24 to 22	0.14 to 0.34 mm ² /AWG26 to 22	0.34 to 0.75 mm ² /AWG22 to 18
	Core wire diameter (including insulating material)	1.0 to 1.6 mm	0.7 to 1.3 mm	1.3 to 2.5 mm
Connection type	Piercecon® connection	QUICKON-ONE connection		
Rating/Performance	Rated current	4 A		
	Rated voltage	60 V	250 V	
	Contact resistance	5 mΩ or less		
	Insulation resistance	100 MΩ or more		
	Withstand voltage	1.0 kV	1.4 kV	
	Ambient temperature	-40 to +85°C	-25 to +80°C	
	Protection class	IP67 (Only with screw tightened)		
	Allowable repeated insertion/withdrawal	100	200	
Allowable number of repeated connection between conductors of the same cross section	10			
Material	Material of knurl	Brass (Nickel plating)	Zinc die-cast (Nickel plating)	
	Contact (Surface treatment)	CuZn (Au plating (Ni underplating))		
	Connector material	PA66 (UL94 V0)		
Weight	Approx. 14 g	Approx. 13 g	Approx. 15 g	

*1 The shaded sections show the specifications for the applicable cable. Adaptation for the connector may vary on account of the conductor construction of the electric wire.

Field-wireable

31 PCA-1557730

Field-wireable connector (M8)

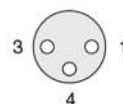
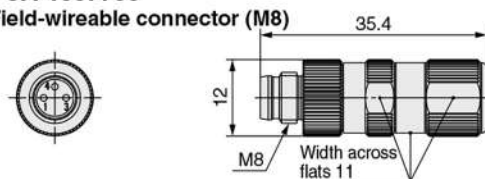

Plug connector pin assignment

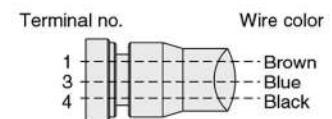

Wiring

32 PCA-1557743

Field-wireable connector (M12)

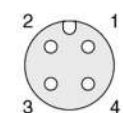
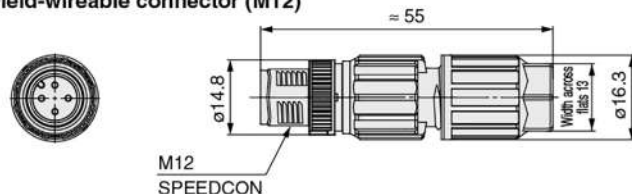

Plug connector pin assignment
A-coded (Normal key)

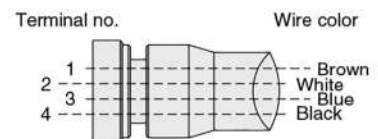

Wiring

33 PCA-1557756

Field-wireable connector (M12)

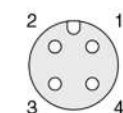
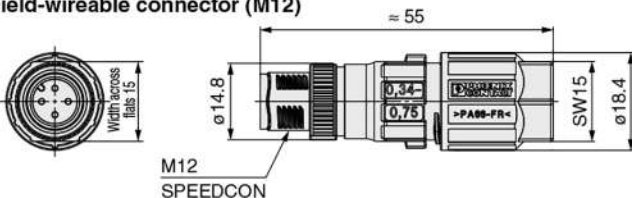

Plug connector pin assignment
A-coded (Normal key)

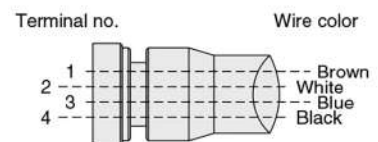





Wiring

Accessory Between the Sensor/Switch and the Input Device

Cable with Connector

Specifications

Part no.	PCA-1557769	PCA-1557772	
Product image	 	 	
Number of functional poles	M12: 4 poles	M8: 3 poles	
Key type	A-coded (Normal key)	—	
Wiring	Fixed cable length	3 m	
	Cable O.D.	4.7 mm	4.4 mm
	Conductor nominal cross section	0.34 mm ² /AWG22	0.25 mm ² /AWG24
	Min. bending radius (Fixed)	47 mm	44 mm
Rating/Performance	Rated current	4 A	
	Rated voltage	250 V	60 V
	Contact resistance	5 mΩ or less	
	Insulation resistance	100 MΩ or more	
	Withstand voltage	1.4 kV	1.0 kV
	Ambient temperature	-25 to +90°C	
	Connector	-40 to +80°C	
	Cable	-40 to +80°C	
Material	Protection class	IP67 (Only with screw tightened)	
	Allowable repeated insertion/withdrawal	200	
	Material of knurl	Zinc die-cast (Nickel plating)	
	Contact (Surface treatment)	CuSn (Au plating (Ni underplating))	
	Connector material	TPU (UL94 HB)	
Material of sheath (Sheath color)	PUR (Black-Gray (RAL 7021 equivalent))		
Weight	Approx. 111 g	Approx. 80 g	

Cable with Connector

34 PCA-1557769 Cable with M12 connector (4 poles)

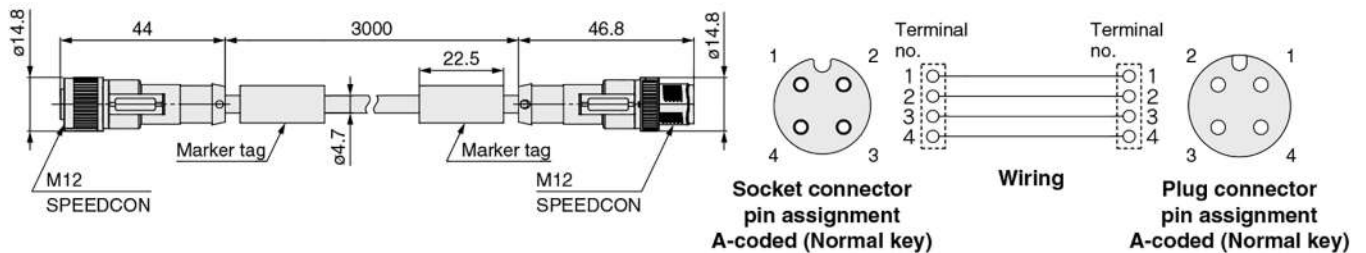

35 PCA-1557772 Cable with M8 connector (3 poles)

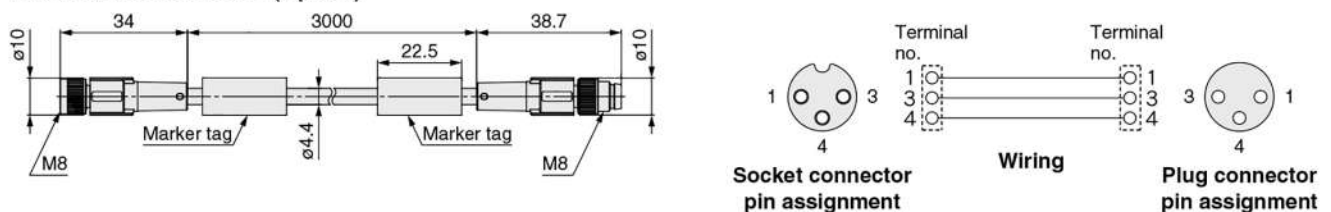

Accessory Between the Sensor/Switch and the Input Device

Y Connector

Specifications

Part no.	PCA-1557785	PCA-1557798
Product image		
Number of functional poles	2 x M12: 5 poles – M12: 5 poles	2 x M8: 3 poles – M12: 4 poles
Key type	A-coded (Normal key)	
Rating/Performance	Rated current	4 A
	Rated voltage	60 V
	Contact resistance	5 mΩ or less
	Insulation resistance	100 MΩ or more
	Withstand voltage	1.0 kV
	Ambient temperature	-25 to +90°C
	Protection class	IP67 (Only with screw tightened)
Allowable repeated insertion/withdrawal	200	
Material	Material of knurl	Zinc die-cast (Nickel plating)
	Contact (Surface treatment)	CuZn (Au plating (Ni underplating))
	Connector material	TPU (UL94 HB)
Weight	Approx. 29 g	Approx. 13 g

Y Connector

36 PCA-1557785
Y connector
(2 x M12-M12)

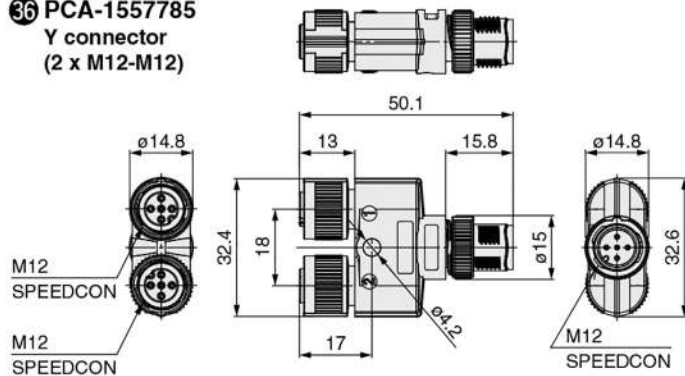

Socket connector
pin assignment
A-coded (Normal key)

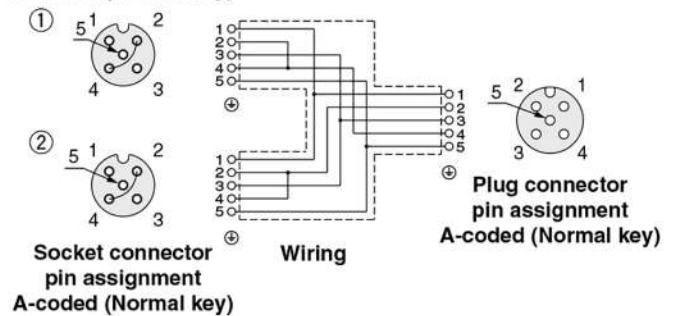

37 PCA-1557798
Y connector
(2 x M8-M12)

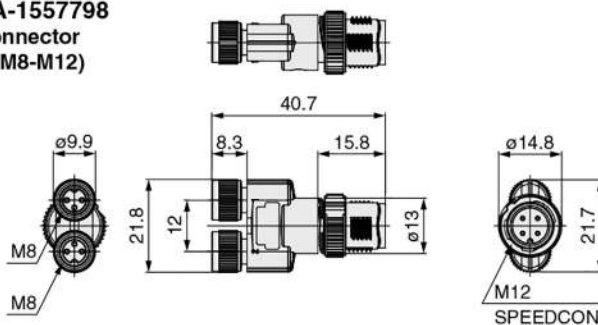

Socket connector
pin assignment

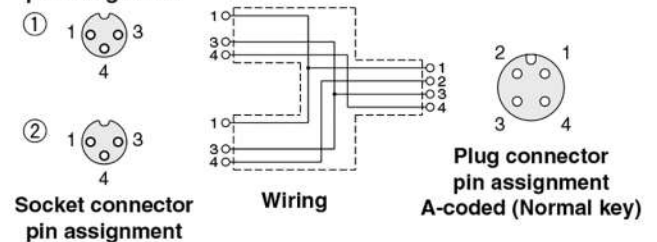

EX9/EX500 Series Other Accessories

A Power Cable with Connector (For power block)

Straight connector type

EX9-AC 050 -1

• Cable length (L)

010	1000 mm
030	3000 mm
050	5000 mm

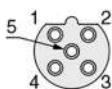

Socket connector
pin arrangement
B-coded
(Reverse key)

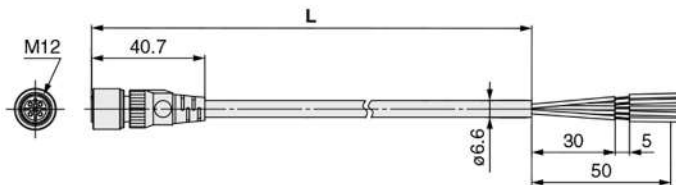

Item	Specifications
Cable O.D.	ø6.6 mm
Conductor nominal cross section	0.3 mm ² /AWG22
Wire O.D. (Including insulator)	1.65 mm
Min. bending radius (Fixed)	40 mm



Made to Order

Cable length	10000 mm	p. 1539
--------------	----------	---------

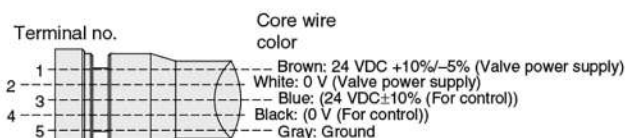

Connections

B Cable with M12 Connector

EX500-AC 030 -SSPS

• Cable length (L)

003	300 mm
005	500 mm
010	1000 mm
030	3000 mm
050	5000 mm
100	10000 mm

• Connector specification

SSPS	Socket side: Straight, Plug side: Straight
SAPA	Socket side: Angle, Plug side: Angle

Straight connector type

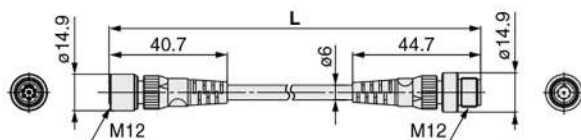

A-coded

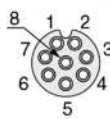

Socket
pin arrangement

Terminal no.

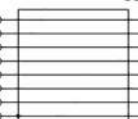
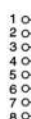

Connections

A-coded

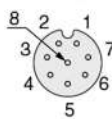

Plug
pin arrangement

Angle connector type

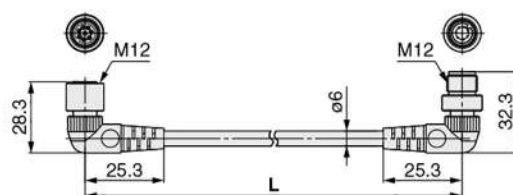

A-coded



Socket
pin arrangement

Terminal no.

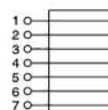

Core wire
color

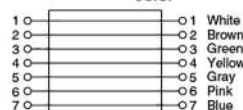

Connections

A-coded

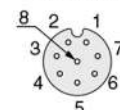

Plug
pin arrangement

Item	Specifications
Cable O.D.	ø6 mm
Conductor nominal cross section	0.25 mm ²
Wire O.D. (Including insulator)	1.27 mm
Min. bending radius (Fixed)	40 mm

Other Accessories

Ⓞ Terminal Plug

This is used in place of an input unit manifold (input unit/input block).
(If a terminal plug is not used, the GW unit's COM LED will not light up.)

EX500-AC000-S

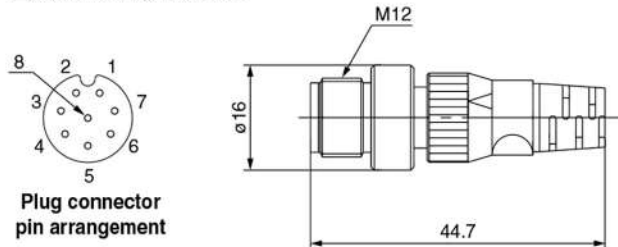

Ⓧ Cable with Connector for Output Entry

Connects the output block to the output device

Straight connector type

EX9-AC 030 -7

• Cable length (L)

010	1000 mm
030	3000 mm

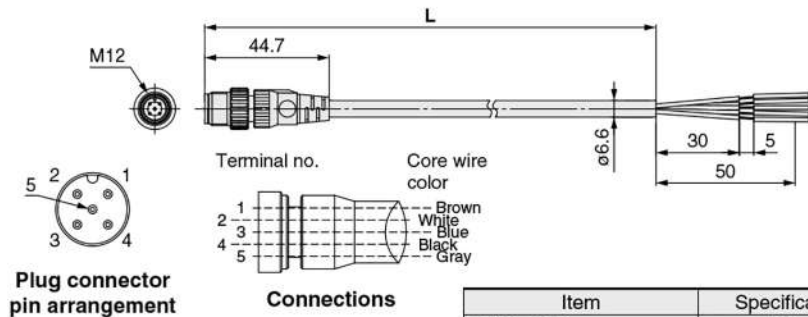

Terminal no.	Core wire color
1	Brown
2	White
3	Blue
4	Black
5	Gray

Connections

Item	Specifications
Cable O.D.	ø6.6 mm
Conductor nominal cross section	0.3 mm ² /AWG22
Wire O.D. (Including insulator)	1.65 mm
Min. bending radius (Fixed)	40 mm

Ⓨ Seal Cap: M12 Connector (For plug)

Use this on ports that are not being used for an M12 connector (plug).
Use of this seal cap maintains the integrity of the enclosure.

* Tighten the seal caps with the prescribed tightening torque. (For M12: 0.1 N·m)

EX500-AWTP

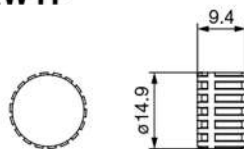

Ⓨ Seal Cap: M8, M12 Connector (For socket)

Use this on ports that are not being used for an M8 or M12 connector (socket). Use of this seal cap maintains the integrity of the enclosure.
(Seal caps are packed together with each unit.)

* Tighten the seal caps with the prescribed tightening torque. (For M8: 0.05 N·m, For M12: 0.1 N·m)

EX9-AW ES

• Connector type

ES	M8 connector (For socket), 10 pcs.
TS	M12 connector (For socket), 10 pcs.

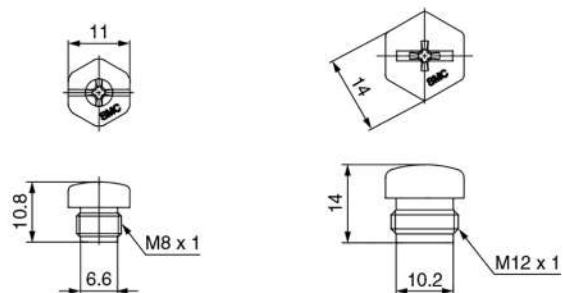

For M8 connector socket

For M12 connector socket

F Power Supply Cable (For connecting the SI unit to the power block)

Connects between the power supply connector for the power block and the SI unit power supply connector, bridging the external power supply, which is supplied with the power block, to the SI unit.

Straight connector type

EX9-AC002-2 2
SI unit type

2	EX250-SDN1 EX250-SMJ2 EX250-SCA1A	Compliant
3	EX250-SPR1 EX250-SEN1	
4	EX250-SAS3/5	Compliant



EX9-AC002-2

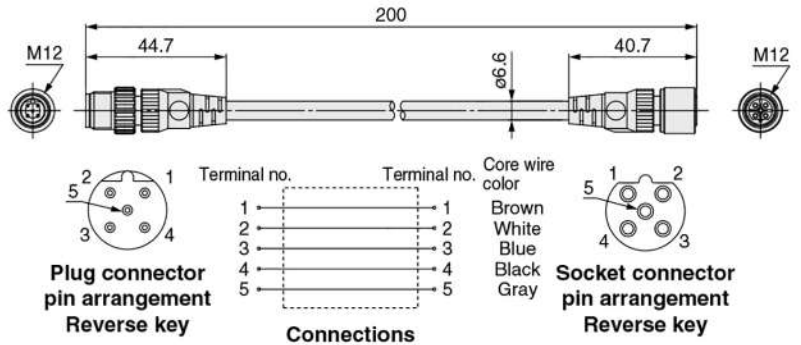

EX9-AC002-3

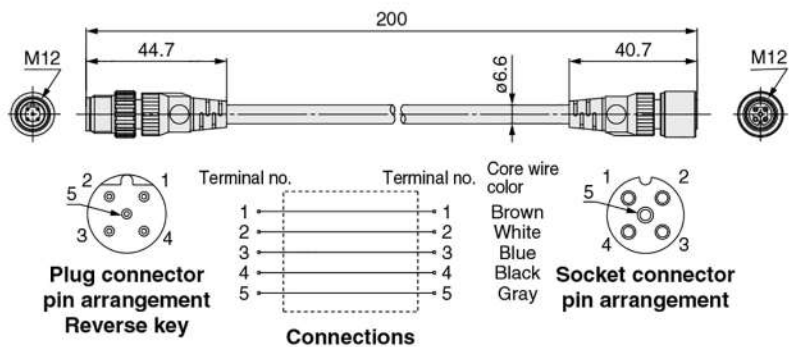

EX9-AC002-4

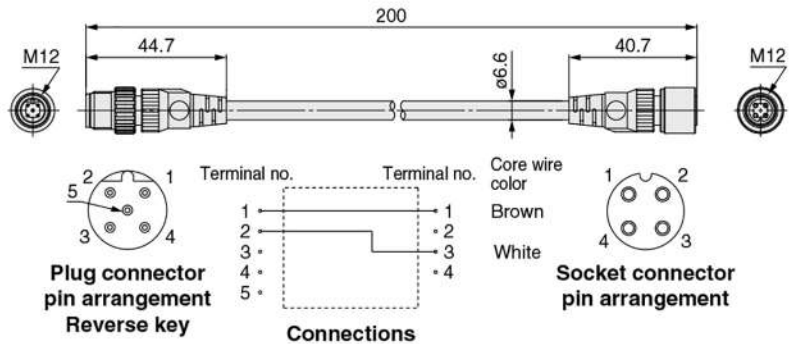

Item	Specifications
Cable O.D.	ø6.6 mm
Conductor nominal cross section	0.3 mm ² /AWG22
Wire O.D. (Including insulator)	1.65 mm
Min. bending radius (Fixed)	40 mm

G AS-Interface Power Supply Cable

Cable connecting between AS-Interface power supply line (for external devices) branch connector (M12) and the power block's power supply input connector.

Straight connector type

EX9-AC010-5 010 -5
Cable length (L)

010	1000 mm
030	3000 mm
050	5000 mm

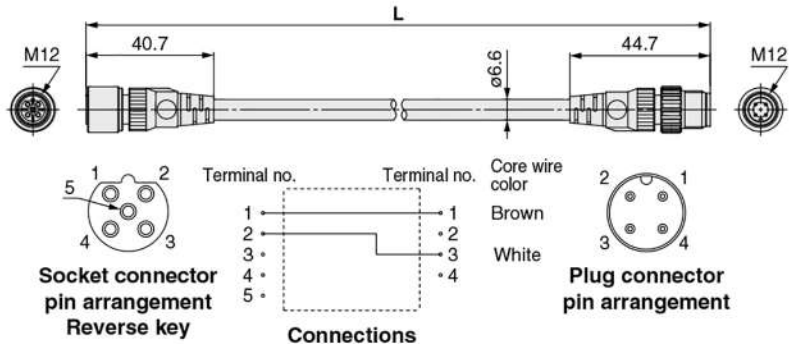

Item	Specifications
Cable O.D.	ø6.6 mm
Conductor nominal cross section	0.3 mm ² /AWG22
Wire O.D. (Including insulator)	1.65 mm
Min. bending radius (Fixed)	40 mm

Made to Order

Communication Cable

With connector on one side (Socket)

Cable length: 10000 mm

For CC-Link For DeviceNet®

EX9-AC100 MJ -X12

• Applicable protocol

MJ	CC-Link
DN	DeviceNet®

Dimensions

For CC-Link

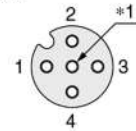
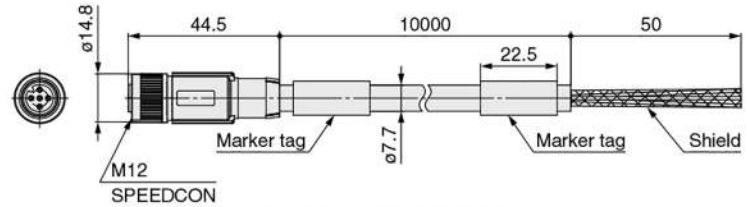

Socket connector pin arrangement A-coded (Normal key)

Connections

Terminal no.	Core wire color: Signal name (CC-Link)
1	Shield: SLD
2	White: DB
3	Yellow: DG
4	Blue: DA

*1 Number of holes: 5, Total number of pins: 4

Item	Specifications	
Cable O.D.	ø7.7 mm	
Conductor nominal cross section	Data pair	0.5 mm ² /AWG20
	Drain	0.34 mm ² /AWG22
Wire O.D. (Including insulator)	2.55 mm	
Min. bending radius (Fixed)	77 mm	

For DeviceNet®

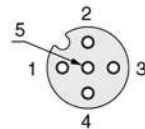
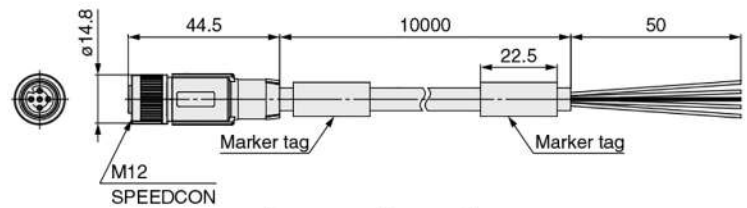

Socket connector pin arrangement A-coded (Normal key)

Connections

Terminal no.	Core wire color: Signal name (DeviceNet®)
1	Shield: DRAIN
2	Red: V+
3	Black: V-
4	White: CAN H
5	Blue: CAN L

Item	Specifications	
Cable O.D.	ø6.7 mm	
Conductor nominal cross section	Power pair	0.34 mm ² /AWG22
	Data pair	0.25 mm ² /AWG24
Wire O.D. (Including insulator)	Power pair	1.4 mm
	Data pair	2.05 mm
Min. bending radius (Fixed)	67 mm	

Power Supply Cable

① **With connector on one side (Socket)**

Cable length: 10000 mm

For EX250/EX260/EX500

EX500-AP100-S-X1

• **Connector specification**

S	Straight
A	Angle

Straight connector type

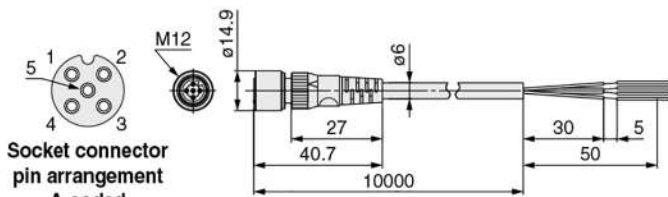

Socket connector pin arrangement A-coded (Normal key)

Item	Specifications
Cable O.D.	ø6 mm
Conductor nominal cross section	0.3 mm ² /AWG22
Wire O.D. (Including insulator)	1.5 mm
Min. bending radius (Fixed)	40 mm

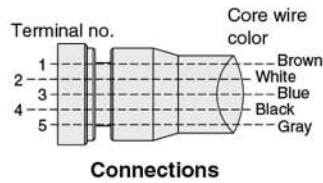

Connections

Angle connector type

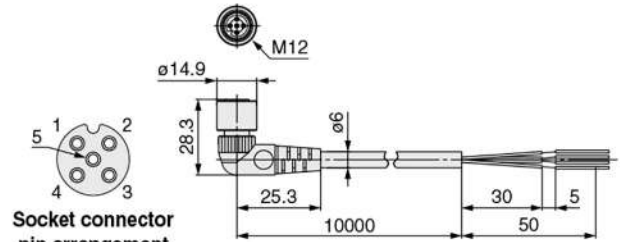

Socket connector pin arrangement A-coded (Normal key)

Item	Specifications
Cable O.D.	ø6 mm
Conductor nominal cross section	0.3 mm ² /AWG22
Wire O.D. (Including insulator)	1.5 mm
Min. bending radius (Fixed)	40 mm

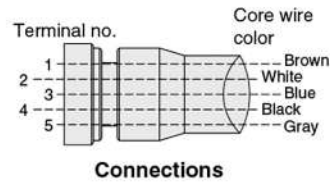

Connections

② **With connector on one side (Socket)**

Cable length: 10000 mm

For EX250/EX260/EX9

Straight connector type

EX9-AC100-1-X16

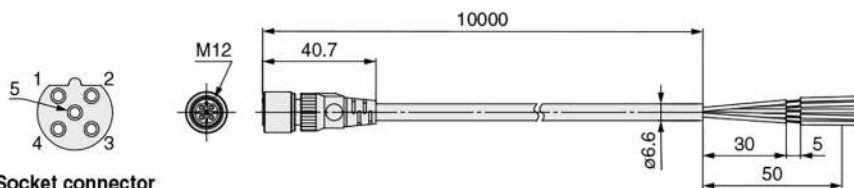

Socket connector pin arrangement B-coded (Reverse key)

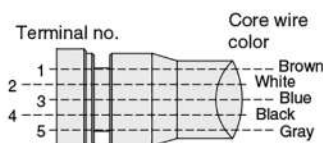

Connections

Item	Specifications
Cable O.D.	ø6.6 mm
Conductor nominal cross section	0.3 mm ² /AWG22
Wire O.D. (Including insulator)	1.65 mm
Min. bending radius (Fixed)	40 mm



PCA/EX9/EX500 Series

Specific Product Precautions 1

Be sure to read this before handling the products. Refer to page 7 for safety instructions and pages 15 to 17 for fieldbus system precautions.

Explanation of Terms

SPEEDCON

There are two types of cable with M12 connector: SPEEDCON compatible and non-compatible. If both plug and socket sides have connectors for SPEEDCON, the cable can be inserted and connected by rotating it 180°, leading to a reduction in labor hours. A non-compatible connector can be connected to a compatible connector as well as an M12.

Marker tag

By inserting the marked insertion label into the tag, the cable can be identified. For details of the insertion label, please make an inquiry to PHOENIX CONTACT.

· Part no.: 1013779 (PABA WH/23)



* If an insertion label is not to be used, the marker tag can be removed before use.

Wiring

⚠ Caution

1. Do not lay the wires while they are energized. Doing so may give you an electric shock.
2. It should be cabled according to the connection diagram.
3. Check if it can be connected when using a sensor or switch.
4. When the cable sheath is stripped, confirm the stripping direction.

(For SMC switches with oblong cables)

The insulator may be split or damaged depending on the direction.

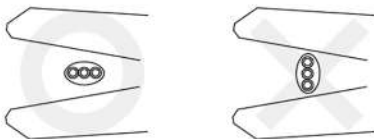

Tightening of Screw

⚠ Caution

1. The enclosure (IP65/67) cannot be maintained and the screws may become loose if they are not tightened sufficiently.
2. Check that they are tightened enough at appropriate intervals during operation.

Connection and Disconnection of Connector

⚠ Caution

1. Be sure to turn the power off when connecting and disconnecting the connectors.
2. Do not touch the engagement surface with wet hands.
3. Do not pull the cable out by holding the cable.
4. Note the key direction.

Especially for the SPEEDCON specification, match the protrusion of the knurl (bracket) and the mark at the mold for insertion so that the SPEEDCON function can be maintained.

5. When engaging the connectors, insert the connectors until the entire engagement surface is no longer visible and tighten the screws so as not to damage the thread ridges.

Handling of Cable with Connector

⚠ Caution

1. Avoid repeatedly bending or stretching the cable and applying heavy objects or force to it.
2. Set up the cables in a place where they will not be stepped on in order to prevent them from being broken and to prevent damage to the connectors. Install a protective cover when deemed necessary.
3. Do not pull the connector or cable unnecessarily. It may damage the connectors or break the cables.
4. Do not bend the cable at the root of the connector when installed.

Handling of Field-wireable Connector

⚠ Caution

Common Precautions

1. Follow the "Assembly Procedure" provided by SMC. If it is not followed correctly, it may not maintain IP65/67.
2. Do not use it for any purpose other than its original purpose.
3. This connector may only be operated when under no load.
4. Working with wet hands may lead to an electric shock.
5. Never attempt to repair the product yourself.

Spring-cage Connection

1. Do not use it for any purpose other than its original purpose.
2. This connector may only be operated when under no load.
3. Working with wet hands may lead to an electric shock.
4. Never attempt to repair the product yourself.



PCA/EX9/EX500 Series

Specific Product Precautions 2

Be sure to read this before handling the products. Refer to page 7 for safety instructions and pages 15 to 17 for fieldbus system precautions.

Handling of Field-wireable Connector

Caution

QUICKON-ONE Connection

1. **Connection between cables** (with the same material and the same cross section) **is 10 times at max.**
2. **PVC or PE is suitable for sheath material, however fluoro resin is not suitable for sheath material.**
3. **Only for flexible cable, not for solid cable.**
4. **When you remove the cable, pull the cable. However, if you remove the cable gland, cable and the splice ring remain to the body.**

When you connect the cable again, screw the splice ring approx. two turns into the cable gland before using.

5. **When you connect the cable again, cut and strip the cable.**

Piercecon® Connection

1. **Connection between cables** (with the same material and the same cross section) **is 10 times at max.**
2. **Only for flexible cable, not for solid cable.**
3. **If you connect the cable again, cut and strip the cable.**

Operating Environment

Caution

1. **Do not use in the atmosphere and environment over the rated specifications.**
2. **Do not use in the environment of corrosive gas or liquid splash.**
3. **Do not use in an environment where oil and chemicals are used.**

Maintenance

Caution

1. **Perform periodic inspection.**