

e-Actuator





 * Excludes size 16
 For details, refer to page 81.

Easy to Operate Integrated Controller RoHS Slider Type/Rod Type/Guide Rod Type

Battery-less Absolute (Step Motor 24 VDC)

Easy to set up, just like air equipment!

Space saving
Built-in controller

Wiring saving

Labor saving
Programless
Reduced adjustment time

Annual CO₂ emissions:
Max. **59%** reduction
(SMC comparison) p. 4

5.8 kg-CO₂e/year (14.1)

* The numerical values vary depending on the operating conditions.

2-position stop

- Single solenoid mode
- Double solenoid mode



Control mode switching

3-position stop

- Closed center mode

Cycle time setting available

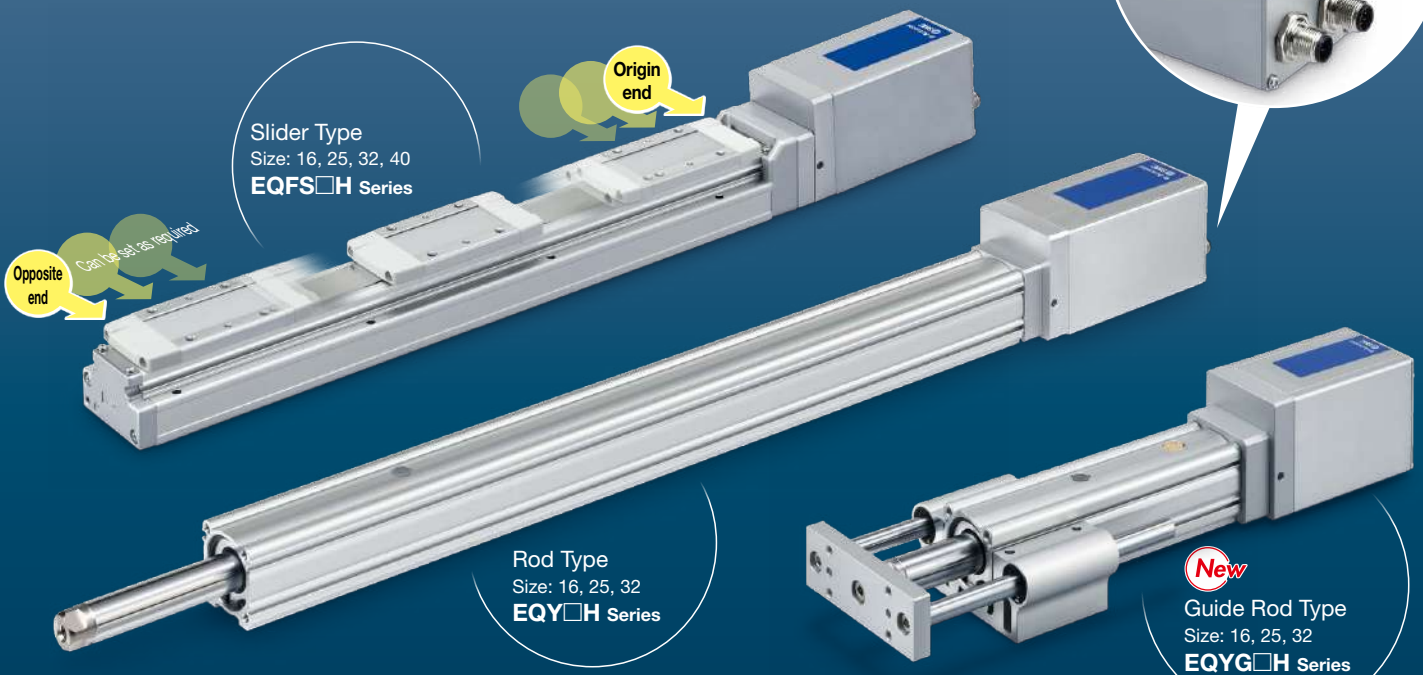

Slider Type
Size: 16, 25, 32, 40
EQFS□H Series

Origin end

Opposite end

Can be set as required

Rod Type
Size: 16, 25, 32
EQY□H Series

New

Guide Rod Type
Size: 16, 25, 32
EQYG□H Series

EQFS□H/EQY□H/EQYG□H Series

 CAT.ES100-154C

Simple setting allows for immediate use.

Two position stop with no programming required

For single solenoid mode (2-position)/
double solenoid mode (2-position)

All configurable on one screen.

Just **2 steps** to complete!

* When used in single solenoid mode, the control mode must be changed.



Step 1 Select the control mode.

Double solenoid mode

Double solenoid mode (2-position)

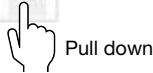

Pull down

Step 2 Set the speed, acceleration, and deceleration.

Operating Conditions

* In these charts, settling time is not included.

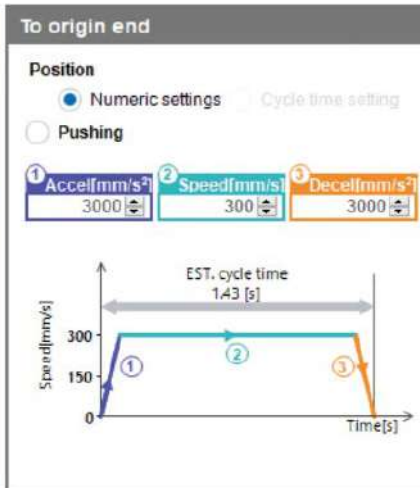
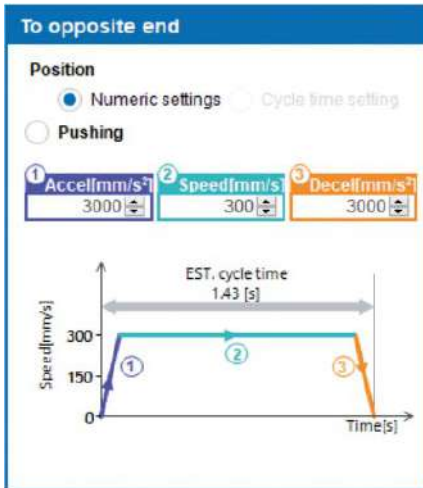

Setting complete Test operation is possible immediately after setting up.



Just press the forward/backward button.

⚠ Caution

The stop position can be changed. For use in positions other than the default setting, refer to the operation manual.

Easy to set intermediate positions

Three position stop with no programming required For closed center mode (3-position)

All configurable on one screen.
 Just **3 steps** to complete!

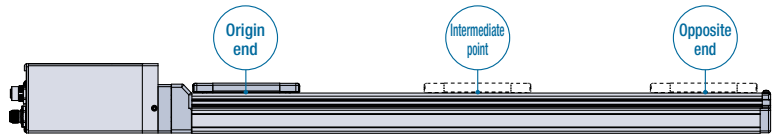

Step 1 Select the control mode.

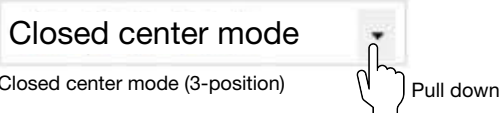

Step 2 Set the intermediate point position.

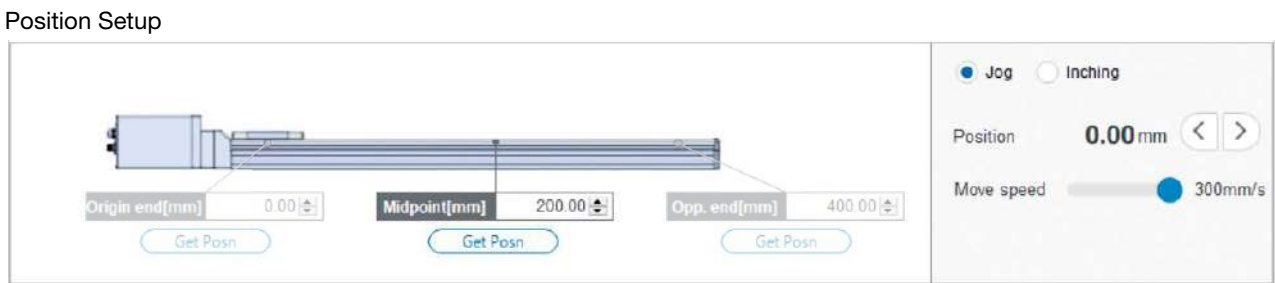

Step 3 Set the speed, acceleration, and deceleration.

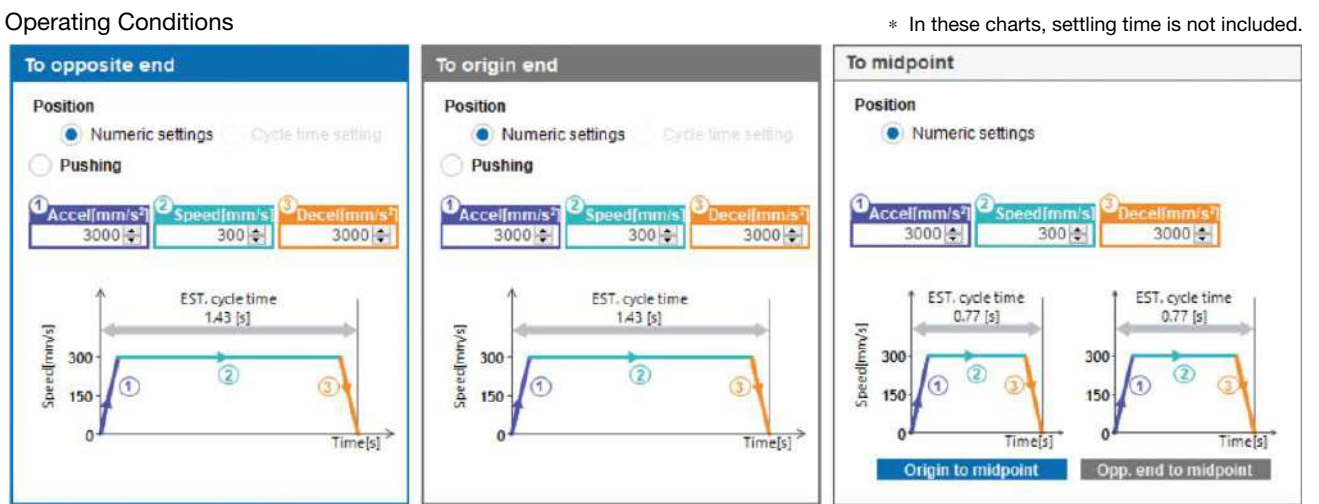

Setting complete Test operation is possible immediately after setting up.

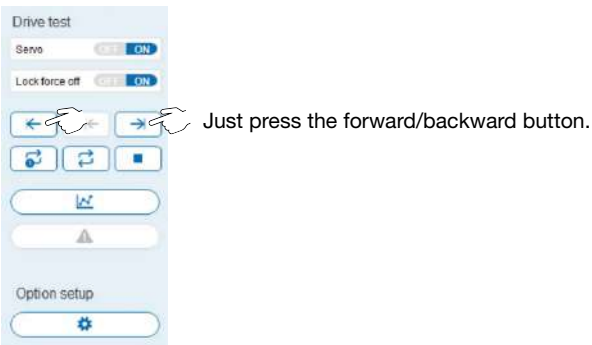

Cycle times are also *easily set*.

Cycle time can be set in all control modes.

For single solenoid mode (2-position)/ double solenoid mode (2-position)



Step 1 Temporary setting of forward and backward speeds, acceleration/deceleration

Operating Conditions

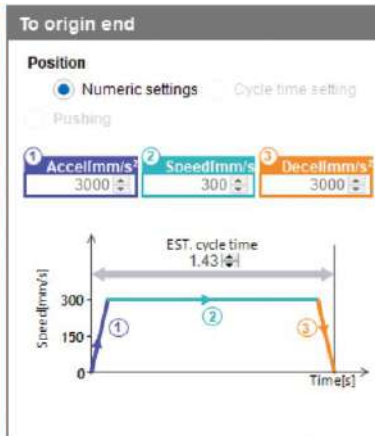
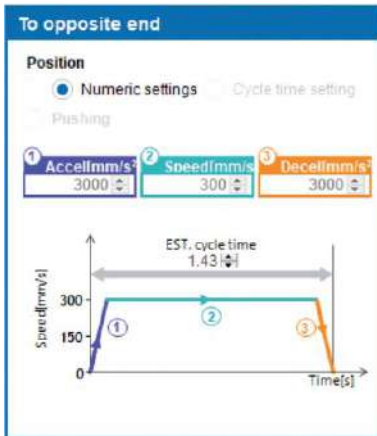

- * In these charts, settling time is not included.
- * The operating conditions to an intermediate point do not correspond to the cycle time setting.
- * Cycle time cannot be set for pushing operation.

Step 2 Operate one cycle and check the graph.

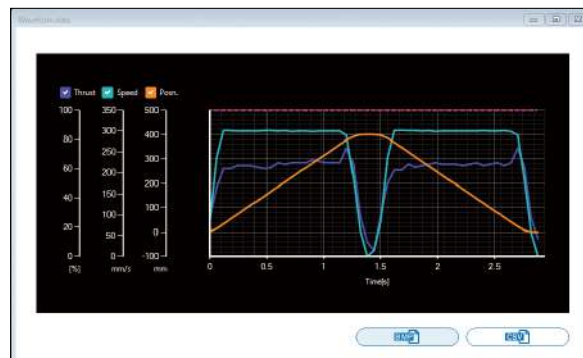
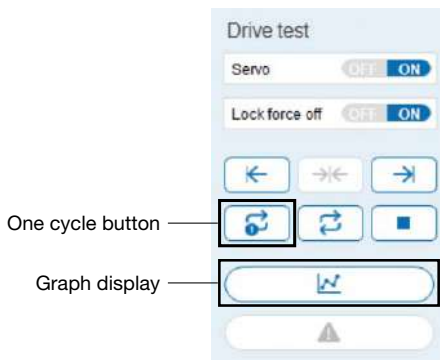

Green: Current speed
 Blue: Current force
 Orange: Current position

Setting complete Adjustable according to cycle time

Operating Conditions

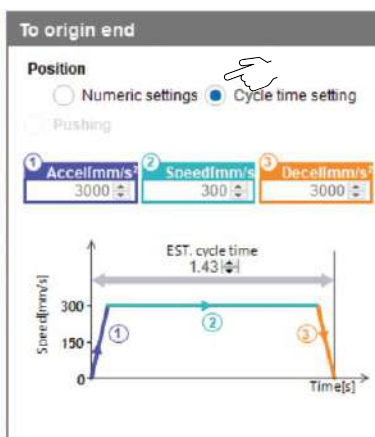
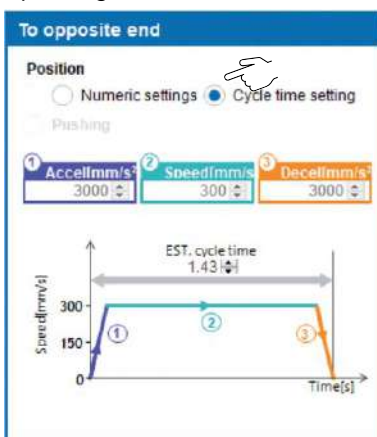

- * In these charts, settling time is not included.

Caution

The stop position can be changed. For use in positions other than the default setting, refer to the operation manual.

Annual CO₂ emissions reduced by up to 59% through motor control optimization (SMC comparison)

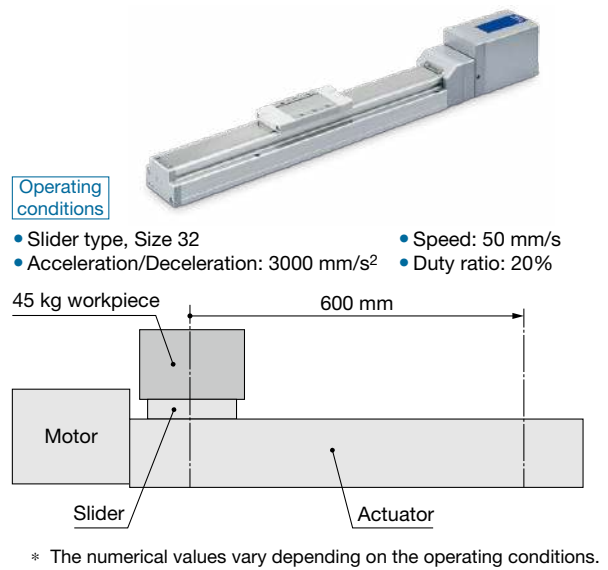
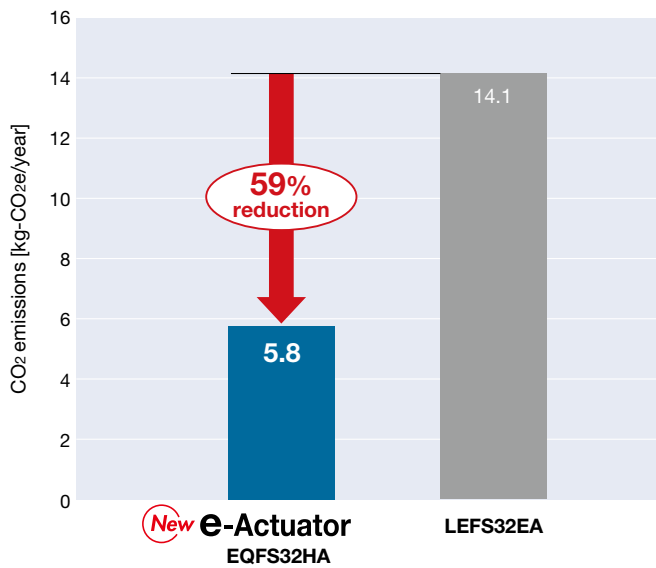

LEDs indicate the load condition.

- PWR Green** : Lights up during normal operation after power on
- ALM Red** : Lights up when an alarm is generated
- OVL Orange** : Lights up when an overload condition occurs

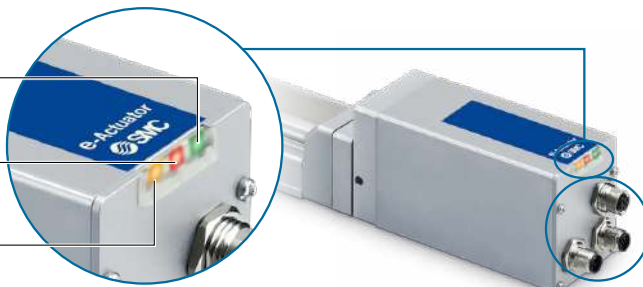

Increased metal connector strength

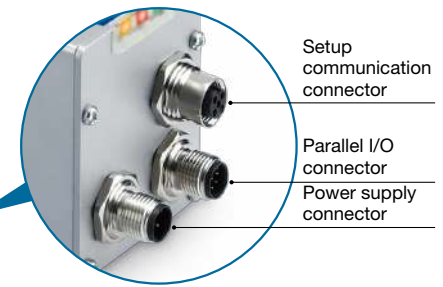

* A female dustproof cap comes with the setup communication connector (M12).

Restart from the last stop position is possible.

Easy operation restart after recovery of the power supply

The position information is held by the encoder even when the power supply is turned off. A return to origin operation is not necessary when the power supply is recovered.

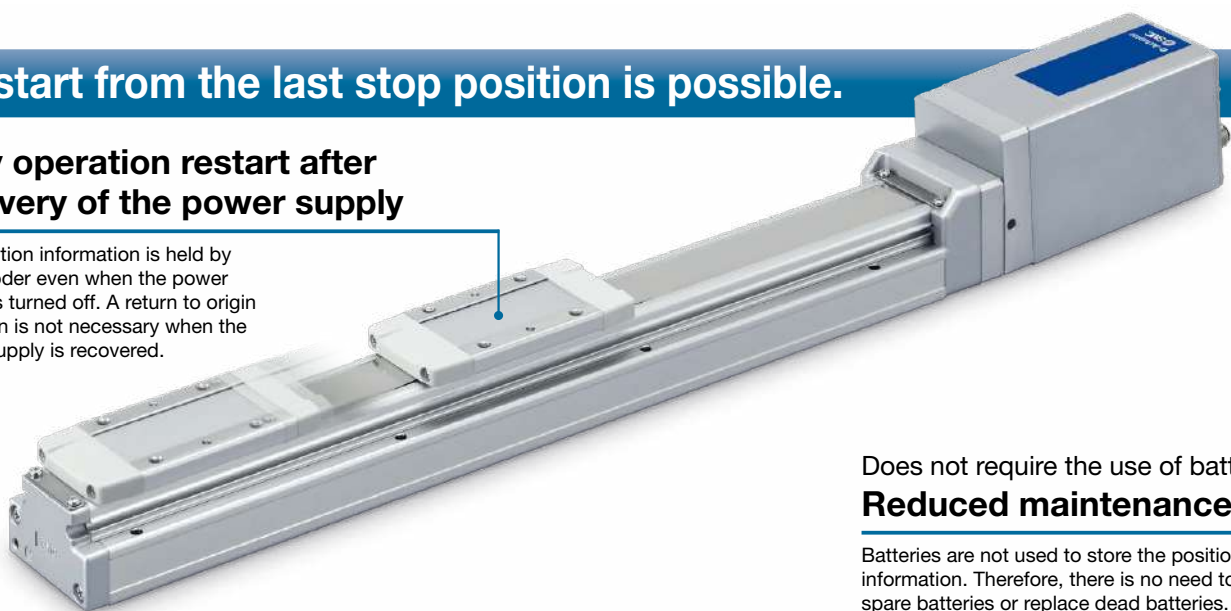

Does not require the use of batteries. Reduced maintenance

Batteries are not used to store the position information. Therefore, there is no need to store spare batteries or replace dead batteries.

Can be selected from 4 directions (In-line motor type)

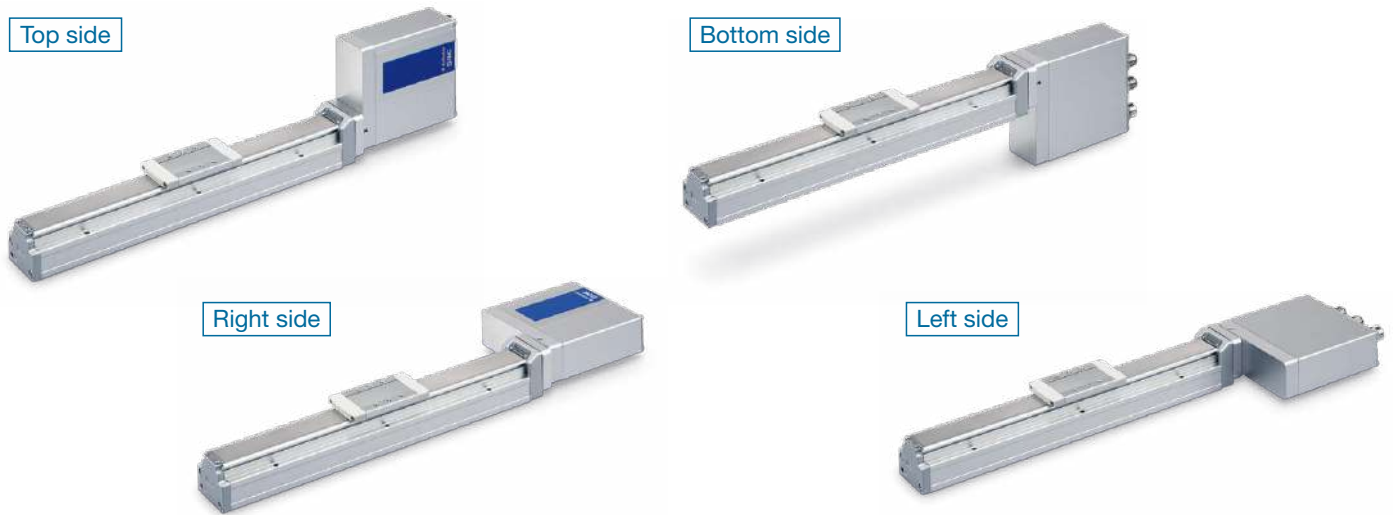

Detection of table stop position by means of an auto switch is possible. p. 29

2-color indicator solid state auto switch (D-M9□ series)

Accurate setting of the mounting position can be performed without mistakes.

A green light lights up when within the optimum operating range.

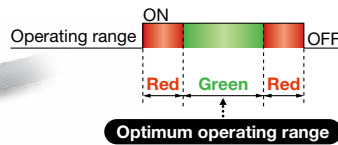

For the slider type

Allows for position detection of the table throughout the stroke



For the rod type/guide rod type

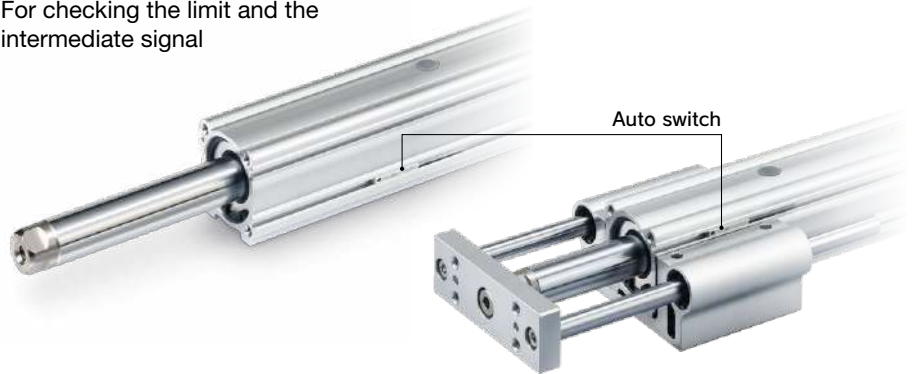

For checking the limit and the intermediate signal

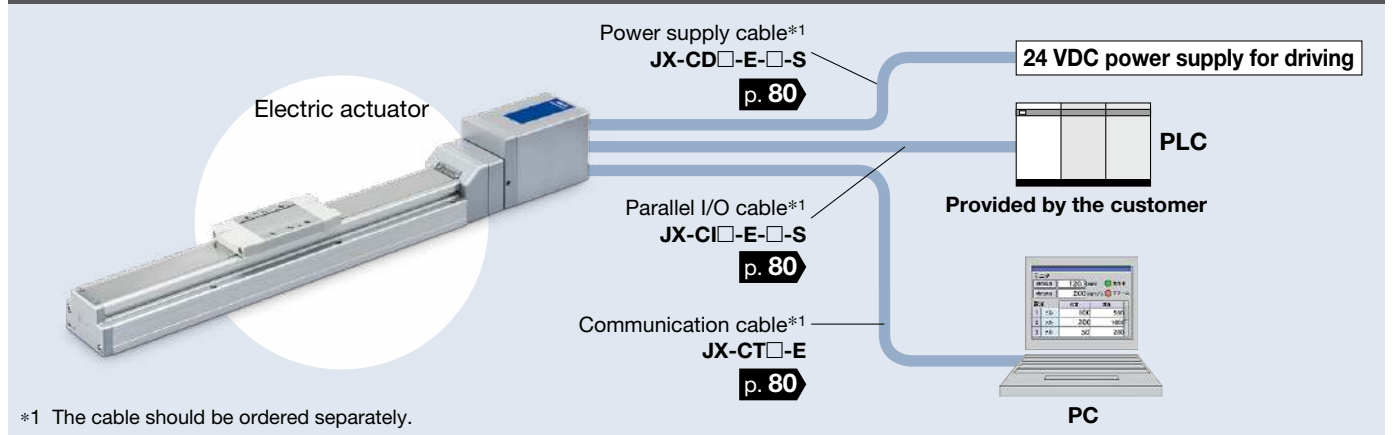

System Construction/General Purpose I/O



Variations

Type	Slider type	Rod type	Guide rod type
Series	EQFS□H  p. 8	EQY□H  p. 34	EQYG□H  p. 56
Actuation type	In-line: Ball screw Parallel: Ball screw + Belt	In-line: Ball screw Parallel: Ball screw + Belt	In-line: Ball screw Parallel: Ball screw + Belt
Max. speed*1 [mm/s]	1200	900	900
Positioning repeatability [mm]	±0.02	±0.02	±0.02
Drive motor	Battery-less absolute (Step motor 24 VDC) <div style="display: flex; justify-content: space-around; margin-top: 5px;"> ● ● ● </div>		
Power supply	24 VDC ±10%		
I/O signal	Parallel input: 3 inputs Parallel output: 4 outputs		
Operation mode	Positioning operation	Positioning operation Pushing operation (Excludes intermediate points)	Positioning operation Pushing operation (Excludes intermediate points)
Size	16	●	●
	25	●	●
	32	●	●
	40	●	—
Max. work load [kg] <small>The values in parentheses are for when mounted vertically</small>	16	18 (12)	40 (10)
	25	40 (15)	70 (30)
	32	68 (20)	100 (46)
	40	80 (40)	—
Max. pushing force [N]	16	—	154
	25	—	511
	32	—	796
	40	—	—
Max. stroke [mm]	1200	500	300
Auto switch mounting	●	●	●

*1 The numerical values vary depending on the actuator type, work load, speed, and specifications. Please contact SMC for further details.

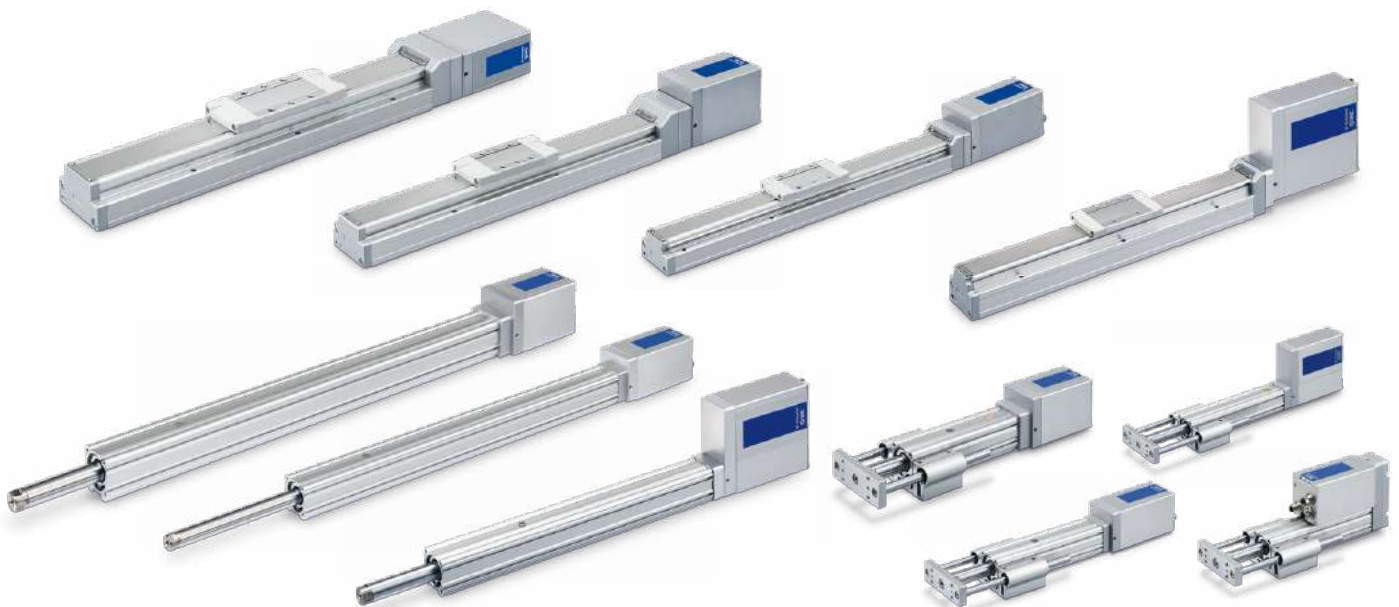

e-Actuator

Easy to Operate Integrated Controller

Slider Type *EQFS*□*H* Series **p. 8**

Battery-less Absolute (Step Motor 24 VDC)

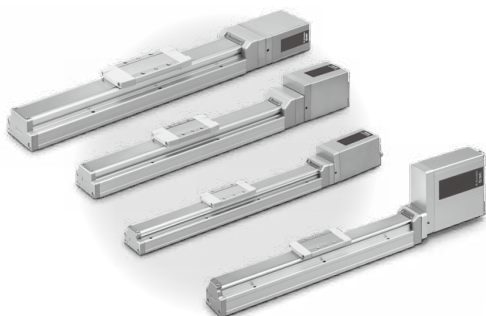

Model Selection	p. 9
How to Order	p. 17
Specifications	p. 18
Construction	p. 20
Dimensions	p. 21

Rod Type *EQY*□*H* Series **p. 34**

Battery-less Absolute (Step Motor 24 VDC)

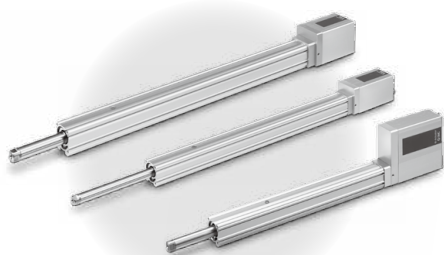

Model Selection	p. 35
How to Order	p. 41
Specifications	p. 42
Construction	p. 44
Dimensions	p. 45

Guide Rod Type *EQYG*□*H* Series **p. 56**

Battery-less Absolute (Step Motor 24 VDC)

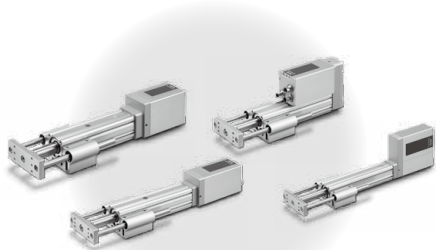

Model Selection	p. 57
How to Order	p. 68
Specifications	p. 69
Construction	p. 71
Dimensions	p. 73
Support Block	p. 77

Auto Switch Mounting	p. 29, 51
Solid State Auto Switch, Normally Closed Solid State Auto Switch, 2-Color Indicator Solid State Auto Switch	p. 30, 52

e-Actuator Electric Specifications	p. 78
Wiring Examples	p. 79
Options	p. 80

e-Actuator

Easy to Operate Integrated Controller / Slider Type

EQFS□H Series

p. 9

Battery-less Absolute (Step Motor 24 VDC)

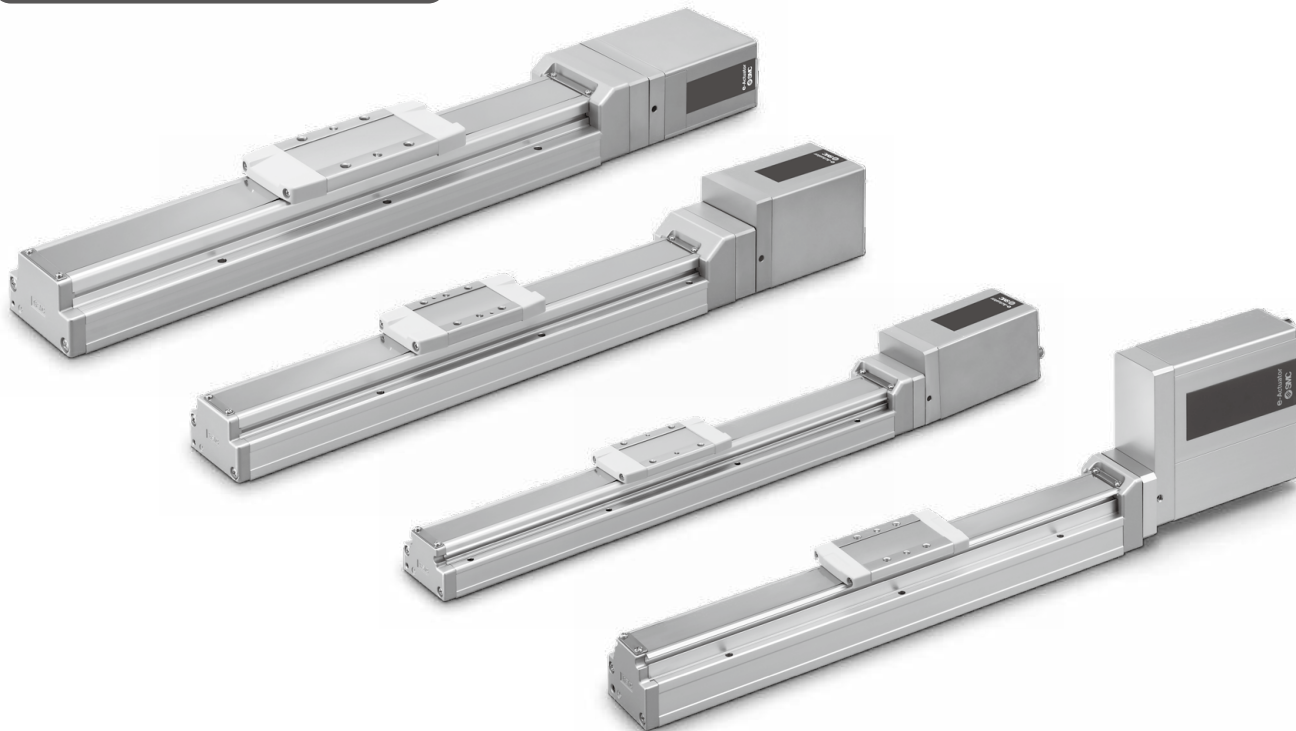

Model Selection

EQFS□H Series

EQY□H Series

EQYG□H Series

Auto Switch

Electric Specifications

Wiring Examples

Options

Model Selection

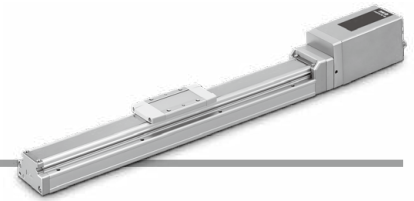

Selection Procedure



Selection Example

Operating conditions

- Workpiece mass: 10 [kg]
- Speed: 300 [mm/s]
- Acceleration/Deceleration: 10000 [mm/s²]
- Stroke: 200 [mm]
- Mounting orientation: Horizontal upward

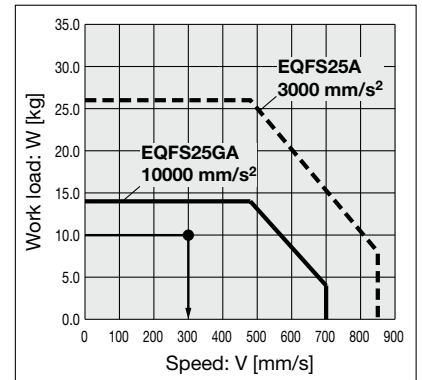
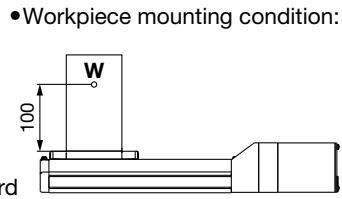

<Speed-Work load graph>
(EQFS25HA/Battery-less absolute)

Step 1 Check the work load-speed. <Speed-Work load graph> (pages 10 to 13)
 Select a model based on the workpiece mass and speed while referencing the speed-work load graph.

Selection example) The **EQFS25HA-200** can be temporarily selected as a possible candidate based on the graph shown on the right side.

Step 2 Check the cycle time.

Calculate the **cycle time** using the following calculation method.

Cycle time:

T can be found from the following equation.

$$T = T1 + T2 + T3 + T4 \text{ [s]}$$

- T1: Acceleration time and T3: Deceleration time can be found by the following equation.

$$T1 = V/a1 \text{ [s]} \quad T3 = V/a2 \text{ [s]}$$

- T2: Constant speed time can be found from the following equation.

$$T2 = \frac{L - 0.5 \cdot V \cdot (T1 + T3)}{V} \text{ [s]}$$

- T4: Settling time varies depending on the conditions such as actuator types, load, and in position of the step data. Reference value for settling time: 0.15 s or less. The following value is used for this calculation.

$$T4 = 0.15 \text{ [s]}$$

Calculation example)

T1 to T4 can be calculated as follows.

$$T1 = V/a1 = 300/10000 = 0.03 \text{ [s]}$$

$$T3 = V/a2 = 300/10000 = 0.03 \text{ [s]}$$

$$T2 = \frac{L - 0.5 \cdot V \cdot (T1 + T3)}{V} = \frac{200 - 0.5 \cdot 300 \cdot (0.03 + 0.03)}{300} = 0.64 \text{ [s]}$$

$$T4 = 0.15 \text{ [s]}$$

The **cycle time** can be found as follows.

$$T = T1 + T2 + T3 + T4 = 0.03 + 0.64 + 0.03 + 0.15 = 0.85 \text{ [s]}$$

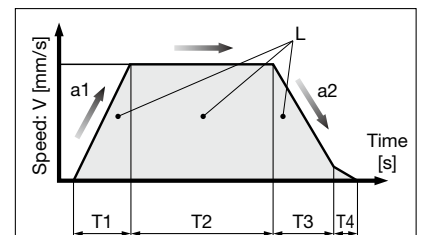

- L : Stroke [mm] ... (Operating condition)
- V : Speed [mm/s] ... (Operating condition)
- a1 : Acceleration [mm/s²] ... (Operating condition)
- a2 : Deceleration [mm/s²] ... (Operating condition)

- T1: Acceleration time [s]
Time until reaching the set speed
- T2: Constant speed time [s]
Time while the actuator is operating at a constant speed
- T3: Deceleration time [s]
Time from the beginning of the constant speed operation to stop
- T4: Settling time [s]
Time until positioning is completed

Step 3 Check the allowable moment. <Static allowable moment> (page 13) <Dynamic allowable moment> (pages 14 and 15)

Confirm the moment that applies to the actuator is within the allowable range for both static and dynamic conditions.

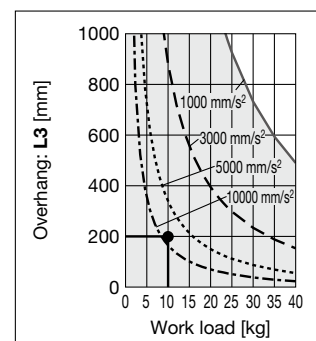
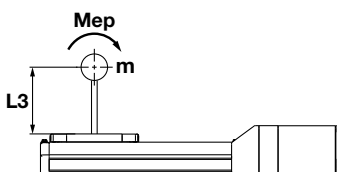

Based on the above calculation result, the **EQFS25A-200** should be selected.

Speed-Work Load Graph (Guide)

EQFS16□HA/Ball Screw Drive

Horizontal/Lead 10

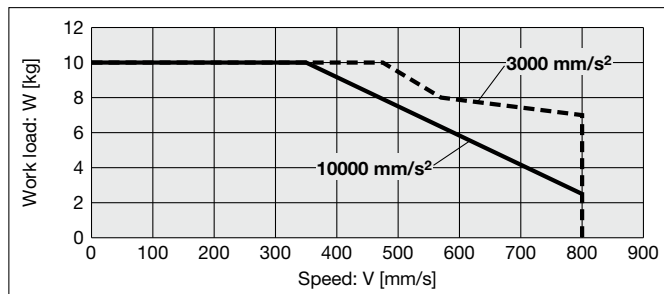

Vertical/Lead 10

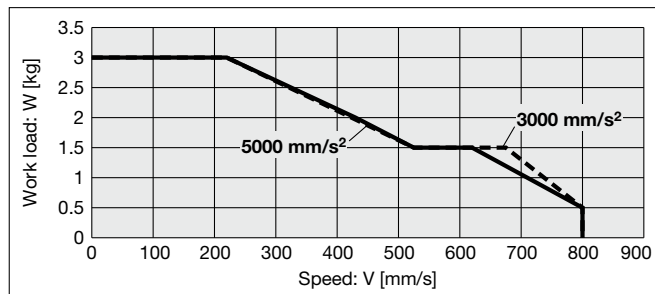

EQFS16□HB/Ball Screw Drive

Horizontal/Lead 5

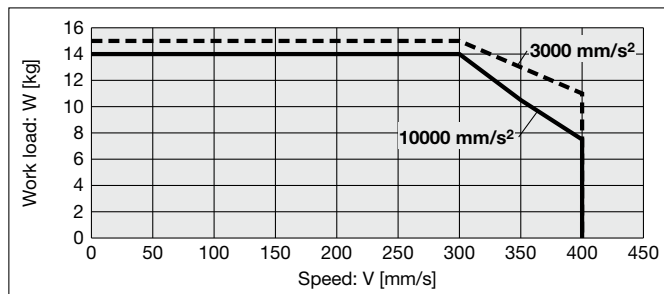

Vertical/Lead 5

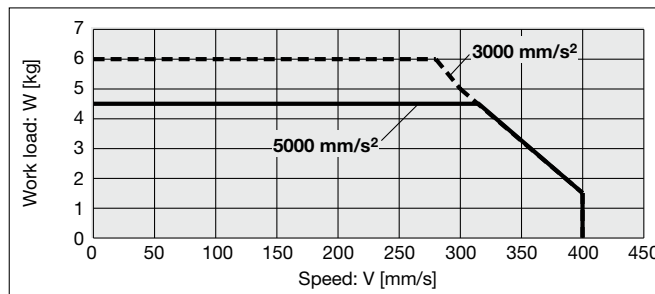

EQFS16□HC/Ball Screw Drive

Horizontal/Lead 2.5

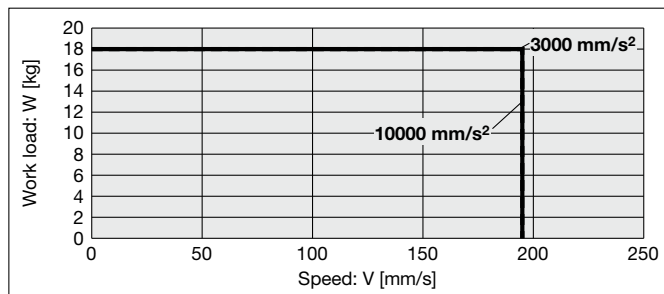

Vertical/Lead 2.5

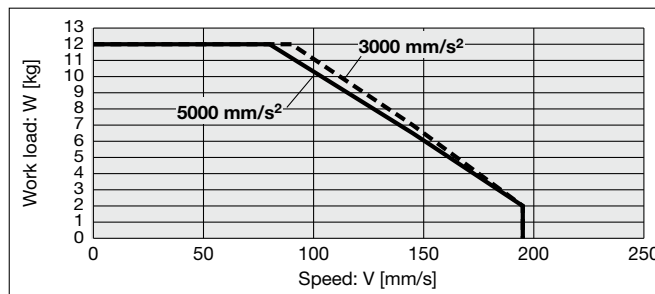

Speed-Work Load Graph (Guide)

EQFS25 HH/Ball Screw Drive

Horizontal/Lead 20

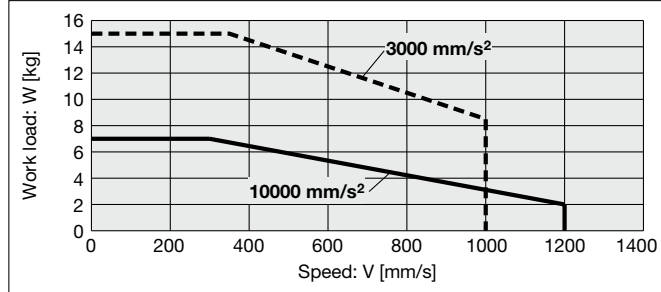

Vertical/Lead 20

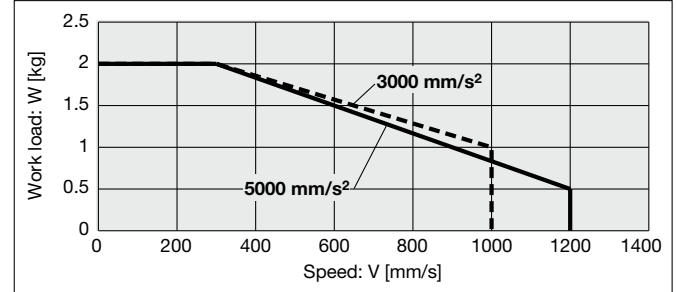

EQFS25 HA/Ball Screw Drive

Horizontal/Lead 12

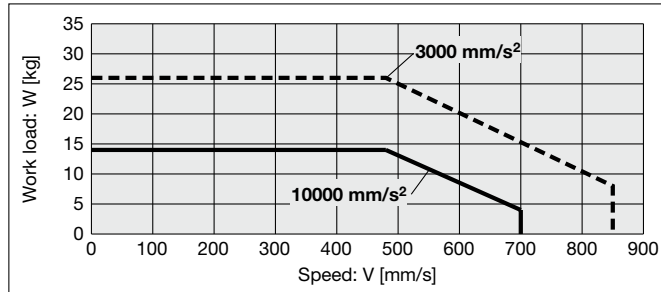

Vertical/Lead 12

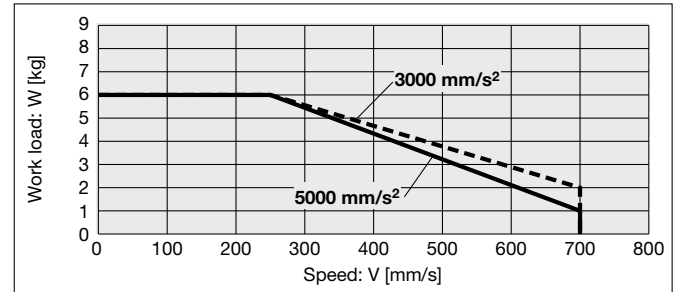

EQFS25 HB/Ball Screw Drive

Horizontal/Lead 6

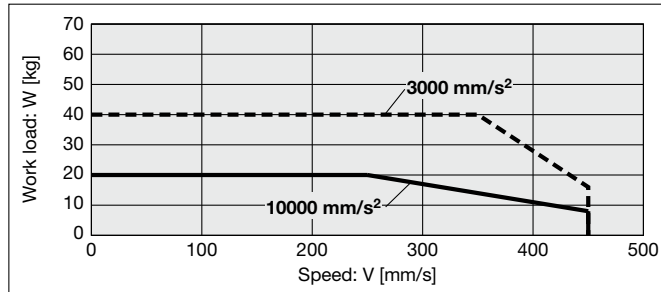

Vertical/Lead 6

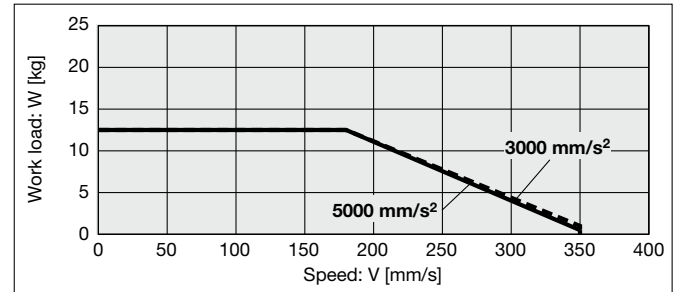

EQFS25 HC/Ball Screw Drive

Horizontal/Lead 3

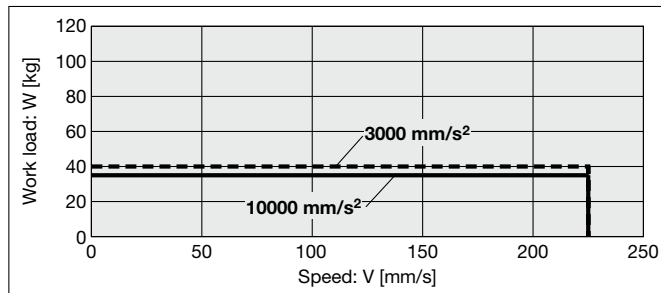

Vertical/Lead 3

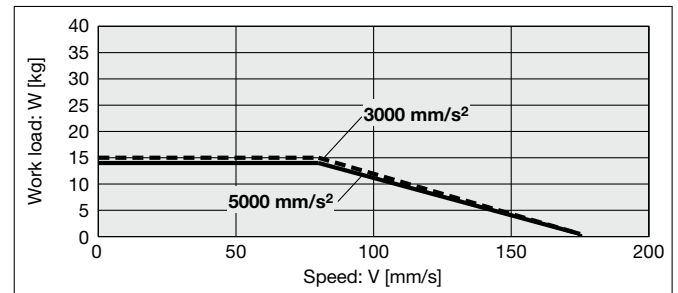

Speed-Work Load Graph (Guide)

EQFS32□HH/ Ball Screw Drive

Horizontal/Lead 24

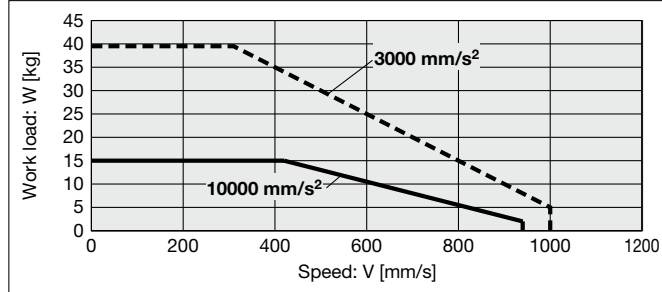

Vertical/Lead 24

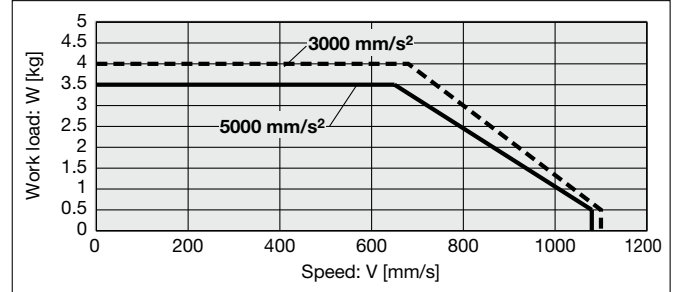

EQFS32□HA/ Ball Screw Drive

Horizontal/Lead 16

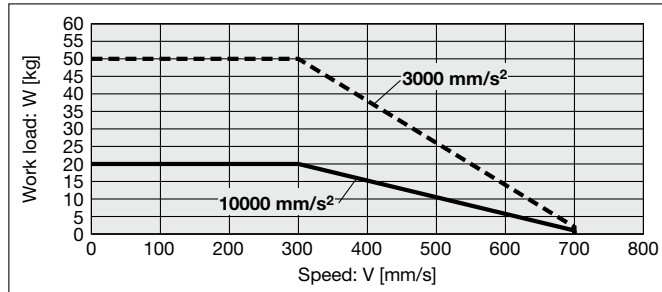

Vertical/Lead 16

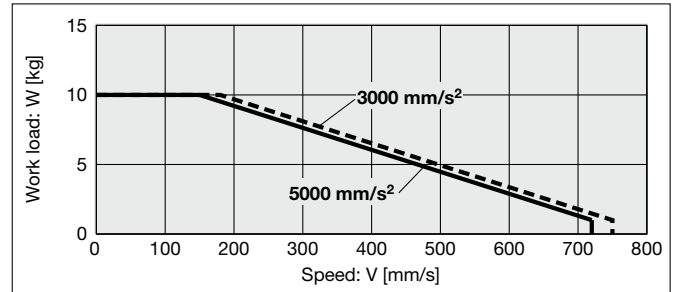

EQFS32□HB/ Ball Screw Drive

Horizontal/Lead 8

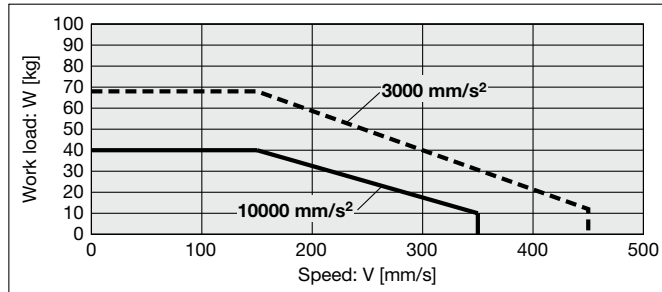

Vertical/Lead 8

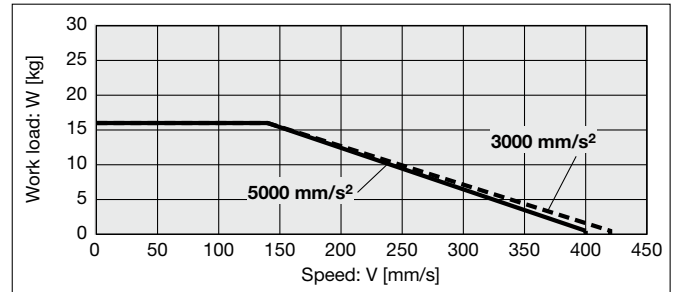

EQFS32□HC/ Ball Screw Drive

Horizontal/Lead 4

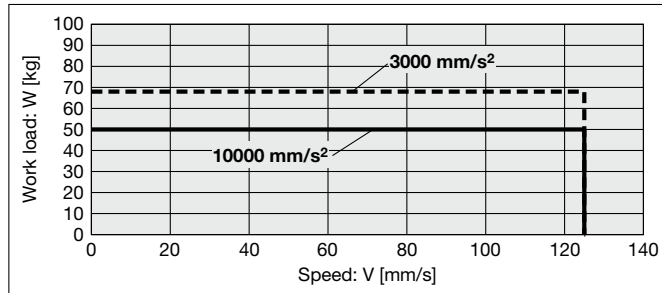

Vertical/Lead 4

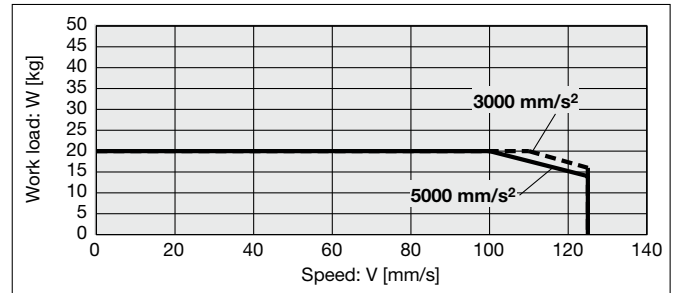

Model Selection
 EQFS□H Series
 EQY□H Series
 EQYG□H Series
 Auto Switch
 Electric Specifications
 Wiring Examples
 Options

Speed-Work Load Graph (Guide)

EQFS40□HH/ Ball Screw Drive

Horizontal/Lead 30

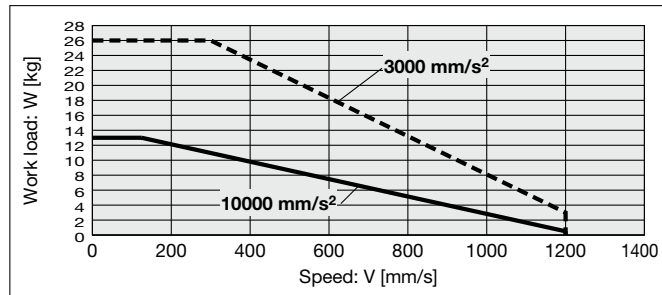

Vertical/Lead 30

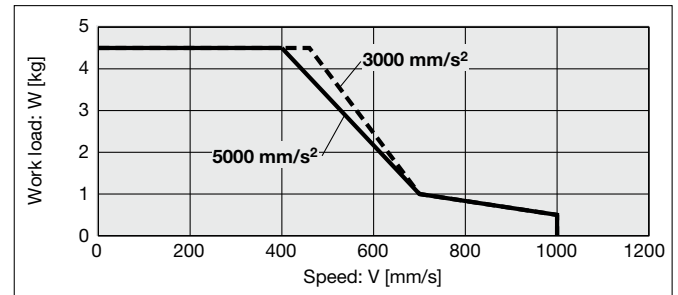

EQFS40□HA/ Ball Screw Drive

Horizontal/Lead 20

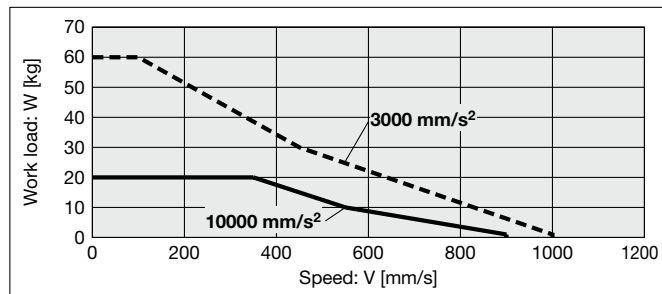

Vertical/Lead 20

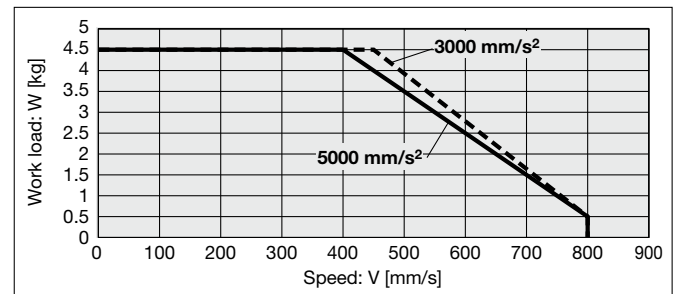

EQFS40□HB/ Ball Screw Drive

Horizontal/Lead 10

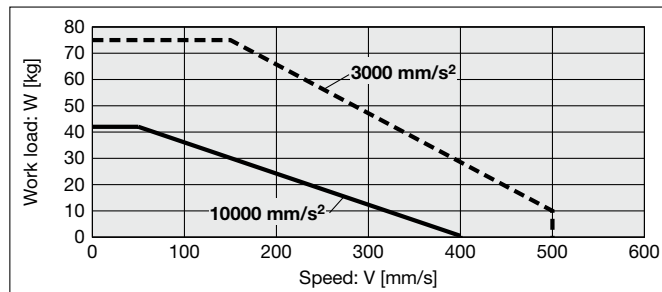

Vertical/Lead 10

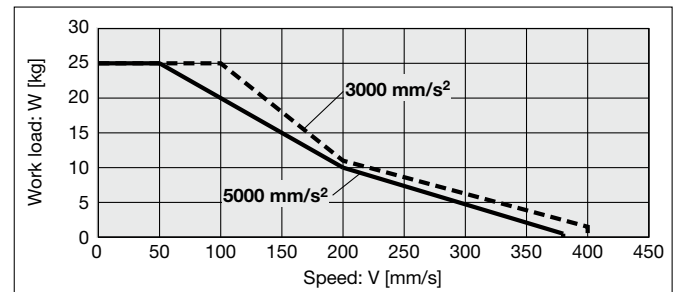

EQFS40□HC/ Ball Screw Drive

Horizontal/Lead 5

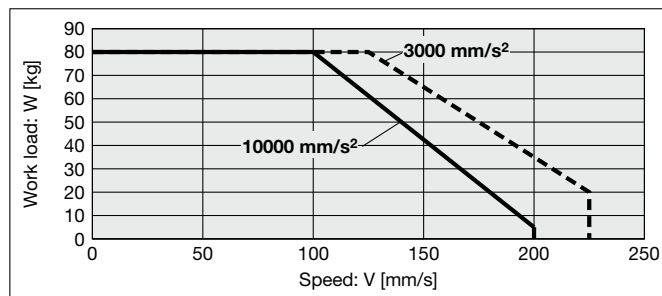

Vertical/Lead 5

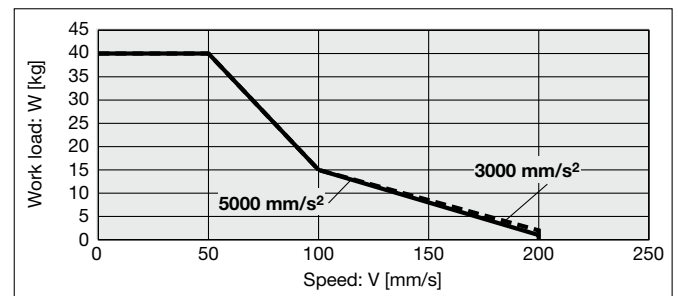

Static Allowable Moment*1

Model	Size	Pitching	Yawing	Rolling
EQFS□H	16	10.0	10.0	20.0
	25	27.0	27.0	52.0
	32	46.0	46.0	101.0
	40	110.0	110.0	207.0

[N·m] *1 The static allowable moment is the amount of static moment which can be applied to the actuator when it is stopped.
 If the product is exposed to impact or repeated load, be sure to take adequate safety measures when using the product.

Dynamic Allowable Moment

* These graphs show the amount of allowable overhang (guide unit) when the center of gravity of the workpiece overhangs in one direction.

Acceleration ——— 1000 mm/s² - - - 3000 mm/s² ····· 5000 mm/s² - - - - 10000 mm/s²

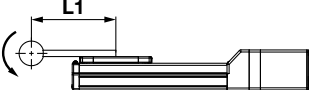
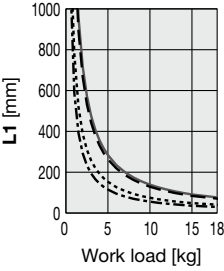
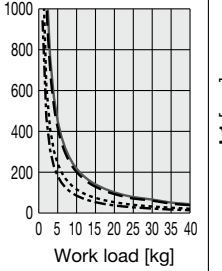
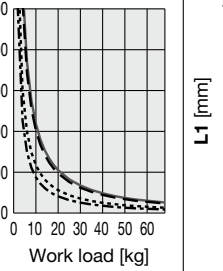
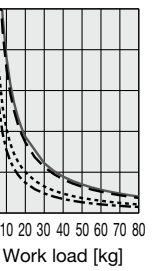
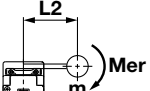
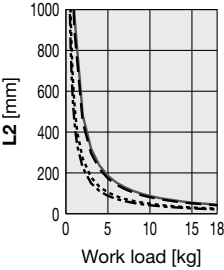
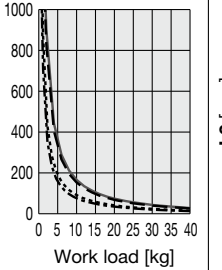
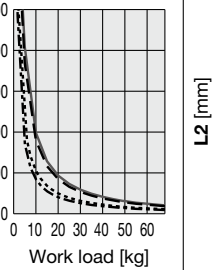
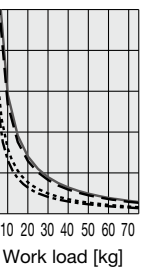
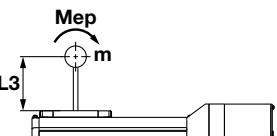
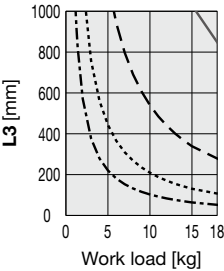
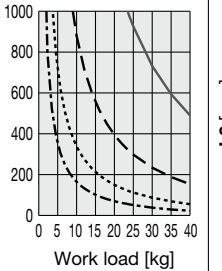
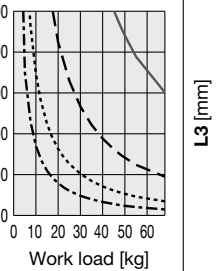
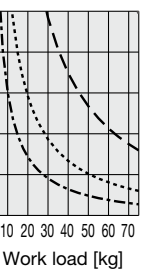
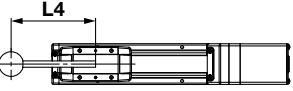
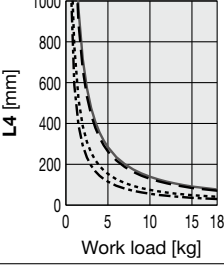
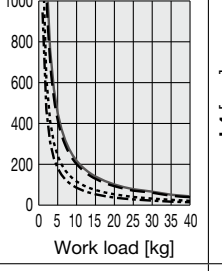
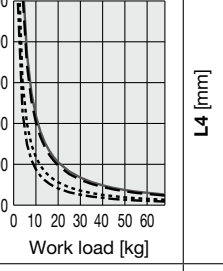
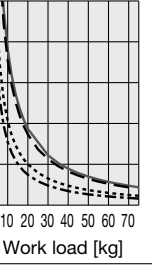
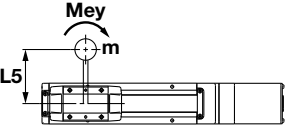
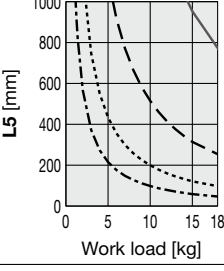
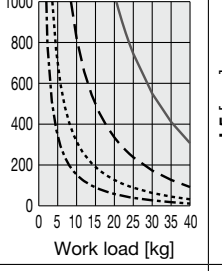
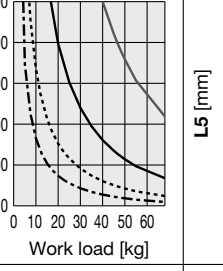
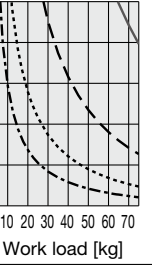
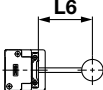
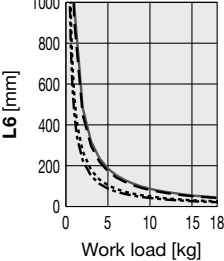
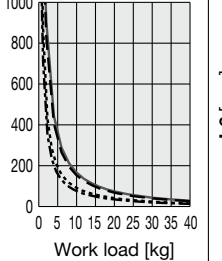
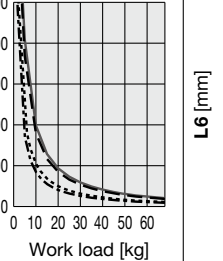
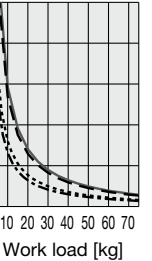
Orientation	Load overhanging direction m : Work load [kg] Me: Allowable moment [N·m] L : Overhang to the work load center of gravity [mm]	Model			
		EQFS16□H	EQFS25□H	EQFS32□H	EQFS40□H
Horizontal/Bottom	 X				
	 Y				
	 Z				
Wall	 X				
	 Y				
	 Z				

Model Selection

EQFS□H Series

EQY□H Series

EQYG□H Series

Auto Switch

Electric Specifications

Wiring Examples

Options

Dynamic Allowable Moment

* These graphs show the amount of allowable overhang (guide unit) when the center of gravity of the workpiece overhangs in one direction.

Acceleration ——— 1000 mm/s² - - - 3000 mm/s² ······ 5000 mm/s²

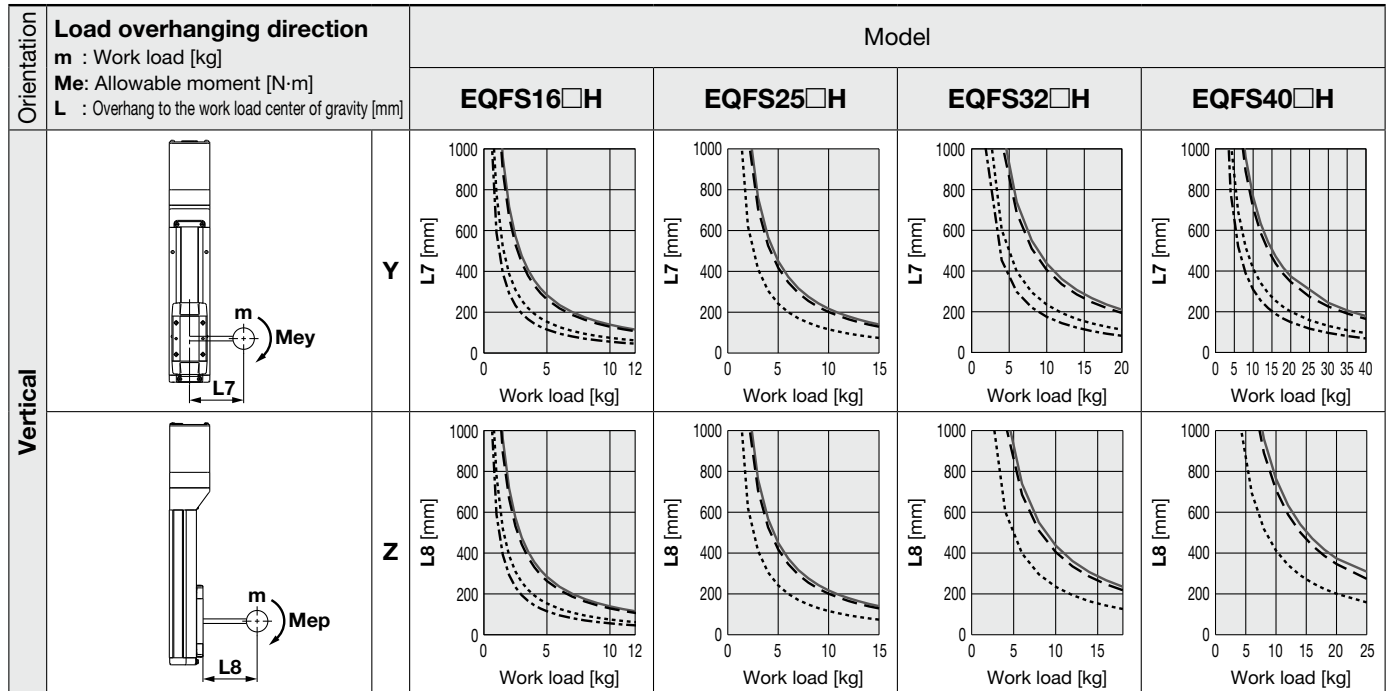

Calculation of Guide Load Factor

- Decide operating conditions.

Model: EQFS□H

Size: 16/25/32/40

Mounting orientation: Horizontal/Bottom/Wall/Vertical

Acceleration [mm/s²]: a

Work load [kg]: m

Work load center position [mm]: Xc/Yc/Zc

- Select the target graph while referencing the model, size, and mounting orientation.

- Based on the acceleration and work load, find the overhang [mm]: Lx/Ly/Lz from the graph.

- Calculate the load factor for each direction.

$$\alpha_x = X_c/L_x, \alpha_y = Y_c/L_y, \alpha_z = Z_c/L_z$$

- Confirm the total of α_x , α_y , and α_z is 1 or less.

$$\alpha_x + \alpha_y + \alpha_z \leq 1$$

When 1 is exceeded, please consider a reduction of acceleration and work load, or a change of the work load center position and series.

Mounting orientation

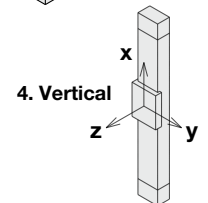
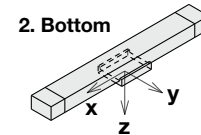
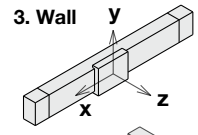
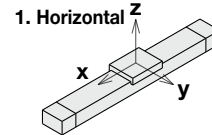

Example

- Operating conditions

Model: EQFS40□H

Size: 40

Mounting orientation: Horizontal

Acceleration [mm/s²]: 3000

Work load [kg]: 20

Work load center position [mm]: Xc = 0, Yc = 50, Zc = 200

- Select the graphs for horizontal of the EQFS40□H on page 14.

- Lx = 350 mm, Ly = 250 mm, Lz = 1000 mm

- The load factor for each direction can be found as follows.

$$\alpha_x = 0/350 = 0$$

$$\alpha_y = 50/250 = 0.2$$

$$\alpha_z = 200/1000 = 0.2$$

- $\alpha_x + \alpha_y + \alpha_z = 0.4 \leq 1$

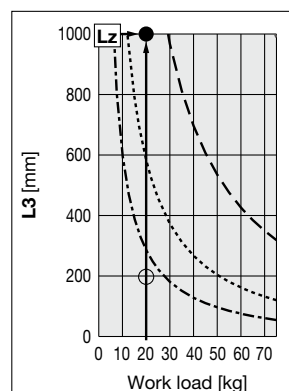
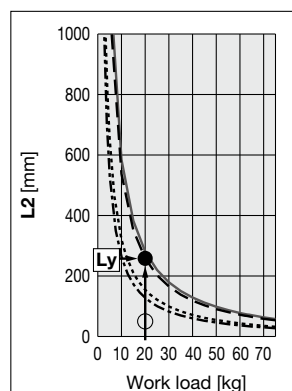
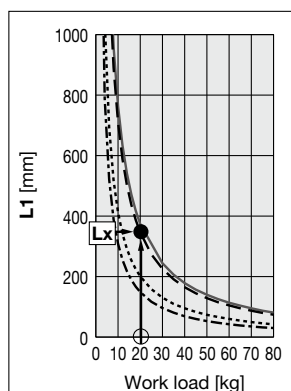
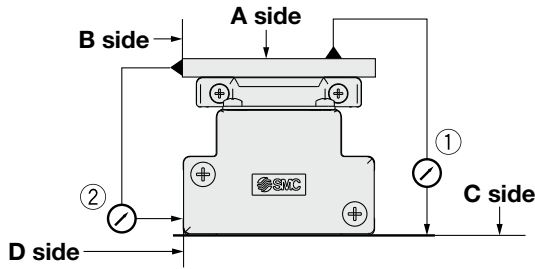

Table Accuracy (Reference Value)



Model	Traveling parallelism [mm] (Every 300 mm)	
	① C side traveling parallelism to A side	② D side traveling parallelism to B side
EQFS16	0.05	0.03
EQFS25	0.05	0.03
EQFS32	0.05	0.03
EQFS40	0.05	0.03

* Traveling parallelism does not include the mounting surface accuracy.
(Excludes when the stroke exceeds 2000 mm)

Table Displacement (Reference Value)

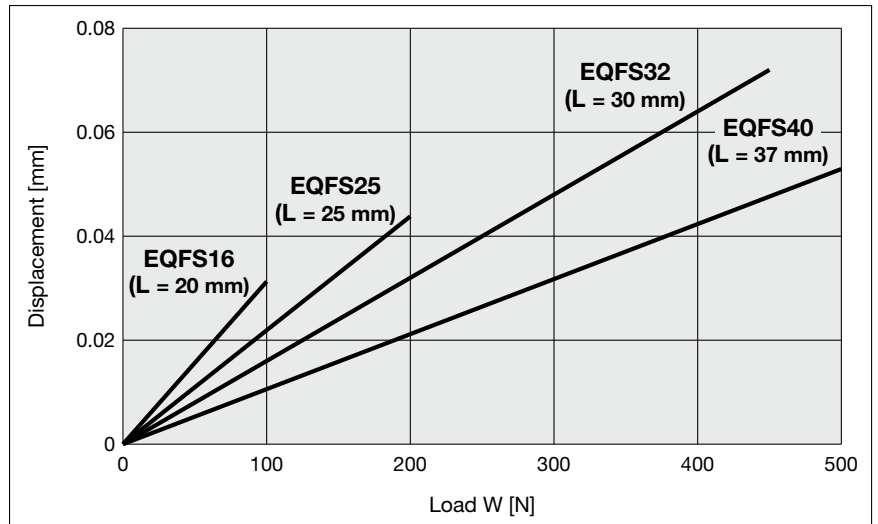
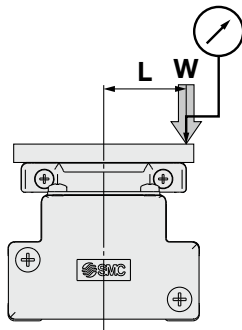

* This displacement is measured when a 15 mm aluminum plate is mounted and fixed on the table.
* Check the clearance and play of the guide separately.

Overhang Displacement Due to Table Clearance (Initial Reference Value)

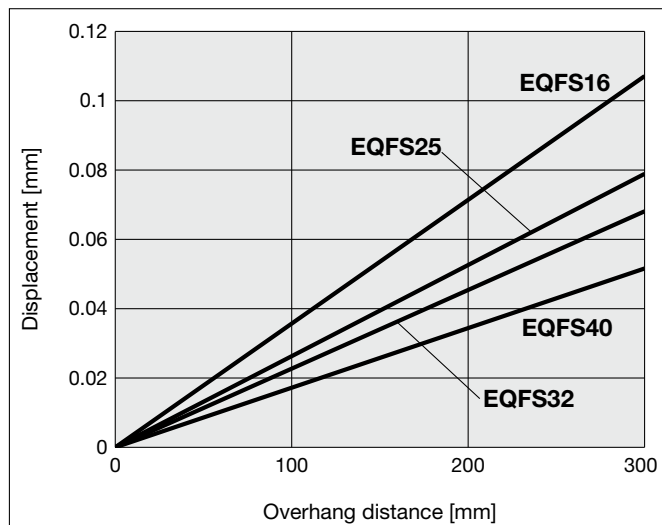

Battery-less Absolute (Step Motor 24 VDC)

e-Actuator Easy to Operate

Integrated Controller / Slider Type

EQFS□H Series EQFS16, 25, 32, 40



* Excludes size 16

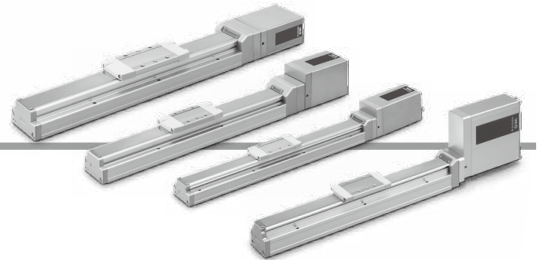

How to Order

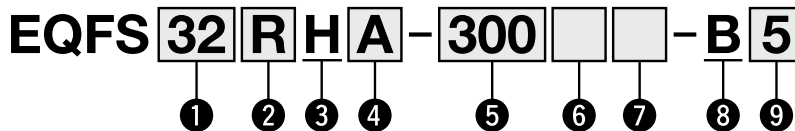

① Size

16
25
32
40

② Motor mounting position/

Motor cover direction

Motor mounting position: In-line

Symbol	Motor cover direction*1	Size
Nil	—	25/32/40
D1	Left side	16
D2	Right side	
D3	Top side	
D4	Bottom side	

*1 This is the direction seen from the connector side.

Motor mounting position: Parallel

Symbol	Direction	Size
R	Right side	16/25/32/40
L	Left side	

③ Motor type

H	Battery-less absolute (Step motor 24 VDC)
---	---

④ Lead [mm]

Symbol	EQFS16	EQFS25	EQFS32	EQFS40
H	—	20	24	30
A	10	12	16	20
B	5	6	8	10
C	2.5	3	4	5

EQFS16 Motor cover direction

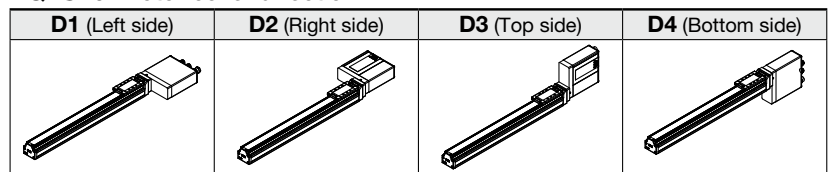

Motor mounting position: Parallel

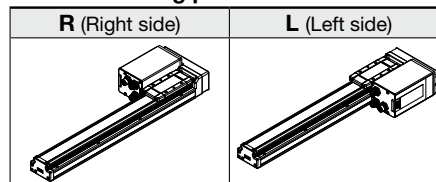

⑤ Stroke

50	50
to	to
1200	1200

* For details, refer to the applicable stroke table below.

⑥ Motor option

Nil	Without option
B	With lock

⑦ Grease application (Seal band part)

Nil	With
N	Without (Roller specification)

⑧ Controller position

B	Integrated controller
---	-----------------------

⑨ Parallel input

5	NPN
6	PNP

The power cable and the parallel I/O cable need to be ordered separately. Refer to page 80 for details.

The auto switches should be ordered separately. For details, refer to pages 29 to 32.

Applicable Stroke Table

Size	Stroke																					
	50	100	150	200	250	300	350	400	450	500	550	600	650	700	750	800	850	900	950	1000	1100	1200
16	●	●	●	●	●	●	●	●	●	●	—	—	—	—	—	—	—	—	—	—	—	—
25	●	●	●	●	●	●	●	●	●	●	●	●	●	●	●	●	—	—	—	—	—	—
32	●	●	●	●	●	●	●	●	●	●	●	●	●	●	●	●	●	●	●	●	—	—
40	—	—	●	●	●	●	●	●	●	●	●	●	●	●	●	●	●	●	●	●	●	●

Specifications

Model		EQFS16□H				EQFS25□H				EQFS32□H				EQFS40□H				
Actuator specifications	Stroke [mm]*1	50 to 500				50 to 800				50 to 1000				150 to 1200				
	Work load [kg]*2	Horizontal	10	15	18	15	26	40	40	39.5	50	68	68	26	60	75	80	
		Vertical	3	6	12	2	6	12.5	15	4	10	16	20	4.5	4.5	25	40	
	Speed [mm/s]	Stroke range	Up to 400	10 to 800	5 to 400	3 to 195	20 to 1200	12 to 850	6 to 450	3 to 225	24 to 1100	16 to 750	8 to 450	4 to 125	30 to 1200	20 to 1000	10 to 500	5 to 225
			401 to 450	10 to 700	5 to 360	3 to 170	20 to 1100	12 to 750	6 to 400	3 to 225	24 to 1100	16 to 750	8 to 450	4 to 125	30 to 1200	20 to 1000	10 to 500	5 to 225
			451 to 500	10 to 600	5 to 300	3 to 140	20 to 1100	12 to 750	6 to 400	3 to 225	24 to 1100	16 to 750	8 to 450	4 to 125	30 to 1200	20 to 1000	10 to 500	5 to 225
			501 to 600	—	—	—	20 to 900	12 to 540	6 to 270	3 to 135	24 to 1100	16 to 750	8 to 400	4 to 125	30 to 1200	20 to 1000	10 to 500	5 to 225
			601 to 700	—	—	—	20 to 630	12 to 420	6 to 230	3 to 115	24 to 930	16 to 620	8 to 310	4 to 125	30 to 1200	20 to 900	10 to 440	5 to 220
			701 to 800	—	—	—	20 to 550	12 to 330	6 to 180	3 to 90	24 to 750	16 to 500	8 to 250	4 to 125	30 to 1140	20 to 760	10 to 350	5 to 175
			801 to 900	—	—	—	—	—	—	—	24 to 610	16 to 410	8 to 200	4 to 100	30 to 930	20 to 620	10 to 280	5 to 140
			901 to 1000	—	—	—	—	—	—	—	24 to 500	16 to 340	8 to 170	4 to 85	30 to 780	20 to 520	10 to 250	5 to 125
			1001 to 1100	—	—	—	—	—	—	—	—	—	—	—	30 to 660	20 to 440	10 to 220	5 to 110
	1101 to 1200	—	—	—	—	—	—	—	—	—	—	—	30 to 570	20 to 380	10 to 190	5 to 95		
	Max. acceleration/ deceleration [mm/s ²]	Horizontal	10000															
		Vertical	5000															
Positioning repeatability [mm]		±0.02																
Lost motion [mm]*3		0.1 or less																
Lead [mm]		10	5	2.5	20	12	6	3	24	16	8	4	30	20	10	5		
Impact/Vibration resistance [m/s ²]*4		50/20																
Actuation type		Ball screw (EQFS□H), Ball screw + Belt (EQFS□ ^R H)																
Guide type		Linear guide																
Operating temperature range [°C]		5 to 40																
Operating humidity range [%RH]		90 or less (No condensation)																
Enclosure		IP30																
Electric specifications	Motor size	□28				□42				□56.4								
	Motor type	Battery-less absolute (Step motor 24 VDC)																
	Encoder	Battery-less absolute																
	Power supply voltage [V]	24 VDC ±10%																
Lock unit specifications	Power [W]*5 *7	Max. power 61				Max. power 89				Max. power 116				Max. power 116				
	Type*6	Non-magnetizing lock																
	Holding force [N]	29	59	118	20	59	123	147	39	98	157	196	44	44	245	392		
	Power [W]*7	2.9				5				5				5				
Rated voltage [V]		24 VDC ±10%																

- *1 Please contact SMC for non-standard strokes as they are produced as special orders.
- *2 The max. work load at 3000 mm/s² acceleration and deceleration speed
Work load varies depending on the speed and acceleration. Check the "Speed-Work Load Graph."
Furthermore, if the cable length exceeds 5 m, the speed and work load specified in the "Speed-Work Load Graph" may decrease by up to 10% for each 5 m increase.
- *3 A reference value for correcting errors in reciprocal operation
- *4 Impact resistance: No malfunction occurred when the actuator was tested with a drop tester in both an axial direction and a perpendicular direction to the lead screw. (The test was performed with the actuator in the initial state.)
Vibration resistance: No malfunction occurred in a test ranging between 45 to 2000 Hz. The test was performed in both an axial direction and a perpendicular direction to the lead screw. (The test was performed with the actuator in the initial state.)
- *5 Indicates the max. power during operation (including the controller). This value can be used for the selection of the power supply.
- *6 With lock only
- *7 For an actuator with lock, add the power for the lock.

Model Selection
 EQFS□H Series
 EQY□H Series
 EQYG□H Series
 Auto Switch
 Electric Specifications
 Wiring Examples
 Options

Weight

In-line Motor

Series	EQFS16									
Stroke [mm]	50	100	150	200	250	300	350	400	450	500
Product weight [kg]	1.06	1.15	1.24	1.33	1.41	1.50	1.59	1.68	1.77	1.86
Additional weight with lock [kg]	0.19									

Series	EQFS25															
Stroke [mm]	50	100	150	200	250	300	350	400	450	500	550	600	650	700	750	800
Product weight [kg]	1.77	1.91	2.05	2.19	2.33	2.47	2.61	2.75	2.89	3.03	3.17	3.31	3.45	3.59	3.73	3.87
Additional weight with lock [kg]	0.31															

Series	EQFS32																			
Stroke [mm]	50	100	150	200	250	300	350	400	450	500	550	600	650	700	750	800	850	900	950	1000
Product weight [kg]	3.12	3.32	3.52	3.72	3.92	4.12	4.32	4.52	4.72	4.92	5.12	5.32	5.52	5.72	5.92	6.12	6.32	6.52	6.72	6.92
Additional weight with lock [kg]	0.58																			

Series	EQFS40																			
Stroke [mm]	150	200	250	300	350	400	450	500	550	600	650	700	750	800	850	900	950	1000	1100	1200
Product weight [kg]	4.99	5.27	5.55	5.83	6.11	6.39	6.77	6.95	7.23	7.51	7.79	8.07	8.35	8.63	8.91	9.19	9.47	9.75	10.31	10.87
Additional weight with lock [kg]	0.60																			

Right/Left Side Parallel Motor*1

Series	EQFS16 ^R _L									
Stroke [mm]	50	100	150	200	250	300	350	400	450	500
Product weight [kg]	1.02	1.11	1.20	1.29	1.37	1.46	1.55	1.64	1.73	1.82
Additional weight with lock [kg]	0.19									

Series	EQFS25 ^R _L															
Stroke [mm]	50	100	150	200	250	300	350	400	450	500	550	600	650	700	750	800
Product weight [kg]	1.75	1.89	2.03	2.17	2.31	2.45	2.59	2.73	2.87	3.01	3.15	3.29	3.43	3.57	3.71	3.85
Additional weight with lock [kg]	0.31															

Series	EQFS32 ^R _L																			
Stroke [mm]	50	100	150	200	250	300	350	400	450	500	550	600	650	700	750	800	850	900	950	1000
Product weight [kg]	3.09	3.29	3.49	3.69	3.89	4.09	4.29	4.49	4.69	4.89	5.09	5.29	5.49	5.69	5.89	6.09	6.29	6.49	6.69	6.89
Additional weight with lock [kg]	0.58																			

Series	EQFS40 ^R _L																			
Stroke [mm]	150	200	250	300	350	400	450	500	550	600	650	700	750	800	850	900	950	1000	1100	1200
Product weight [kg]	5.15	5.43	5.71	5.99	6.27	6.55	6.93	7.11	7.39	7.67	7.95	8.23	8.51	8.79	9.07	9.35	9.63	9.91	10.47	11.03
Additional weight with lock [kg]	0.60																			

*1 The product weight in the table includes the weight of the table spacer.

Table Spacer Weight [g]

EQFS16 ^R _L	5
EQFS25 ^R _L	95
EQFS32 ^R _L	125
EQFS40 ^R _L	30

Construction

In-line motor

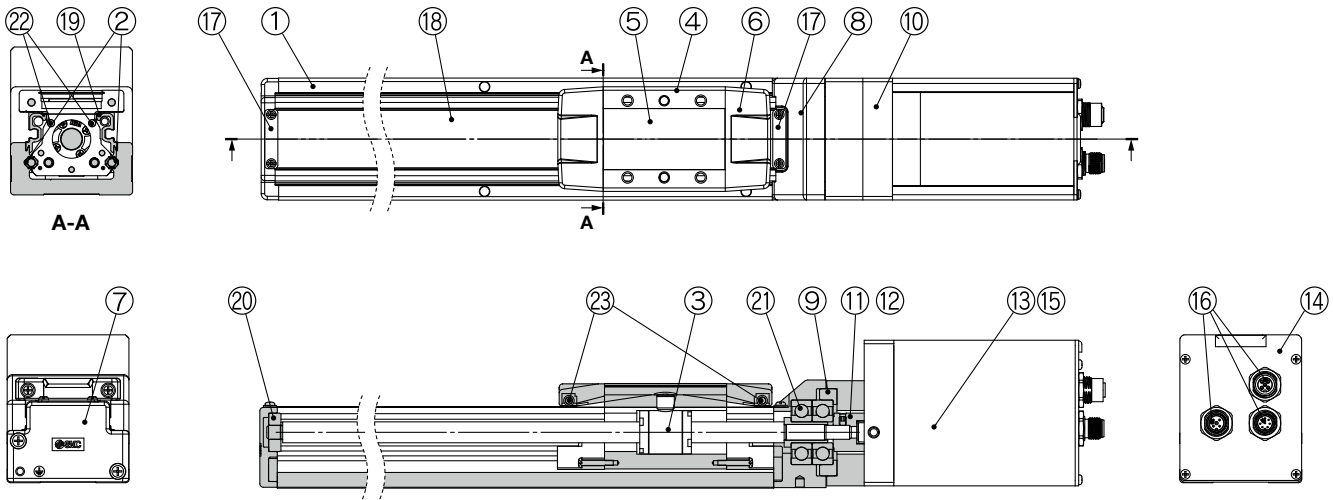

Right/Left side parallel motor

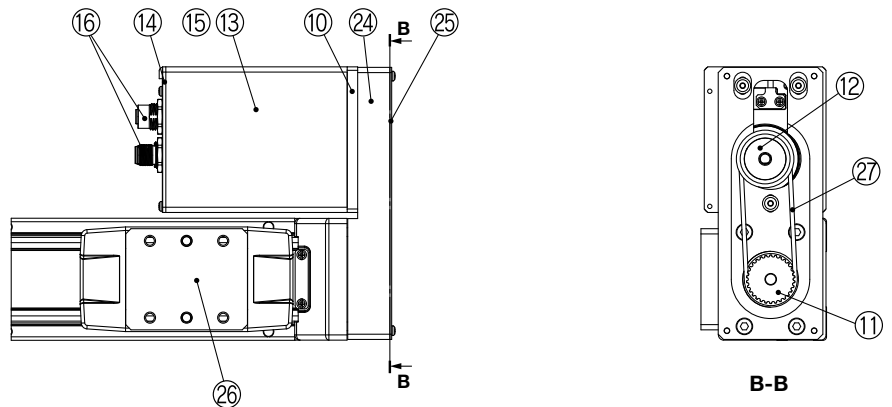

Component Parts

No.	Description	Material	Note
1	Body	Aluminum alloy	Anodized
2	Rail guide	—	
3	Ball screw assembly	—	
4	Table	Aluminum alloy	Anodized
5	Blanking plate	Aluminum alloy	Anodized
6	Seal band holder	Synthetic resin	
7	Housing A	Aluminum die-casted	Coating
8	Housing B	Aluminum die-casted	Coating
9	Bearing stopper	Aluminum alloy	
10	Motor adapter	Aluminum alloy	Coating
11	Screw hub/pulley	Aluminum alloy	
12	Motor hub/pulley	Aluminum alloy	
13	Motor cover	Aluminum alloy	Anodized
14	End cover	Aluminum alloy	Anodized
15	Motor	—	
16	Connector	—	
17	Band stopper	Stainless steel	
18	Dust seal band	Stainless steel	
19	Seal magnet	—	
20	Bearing	—	201 mm stroke or more
21	Bearing	—	
22	Magnet	—	
23	Roller shaft	Stainless steel	Without grease application

Component Parts (Right/Left side parallel only)

No.	Description	Material	Note
24	Return plate	Aluminum alloy	Coating
25	Cover plate	Aluminum alloy	Anodized
26	Table spacer	Aluminum alloy	Anodized
27	Belt	—	

Replacement Parts (Right/Left side parallel only)/Belt

No.	Size	Order no.
27	16	LE-D-6-5
	25	LE-D-15-1
	32	LE-D-19-1
	40	LE-D-19-2

Replacement Parts/Grease Pack

Applied portion	Order no.
Ball screw	GR-S-010 (10 G) GR-S-020 (20 G)
Rail guide	
Dust seal band	
(When "Without" is selected for the grease application, grease is applied only on the back side.)	

Model Selection

EQFS□H Series

EQY□H Series

EQYG□H Series

Auto Switch

Electric Specifications

Wiring Examples

Options

Dimensions: In-line Motor

EQFS16H

* This drawing shows the EQFS16D3H (Motor cover direction: Top side).

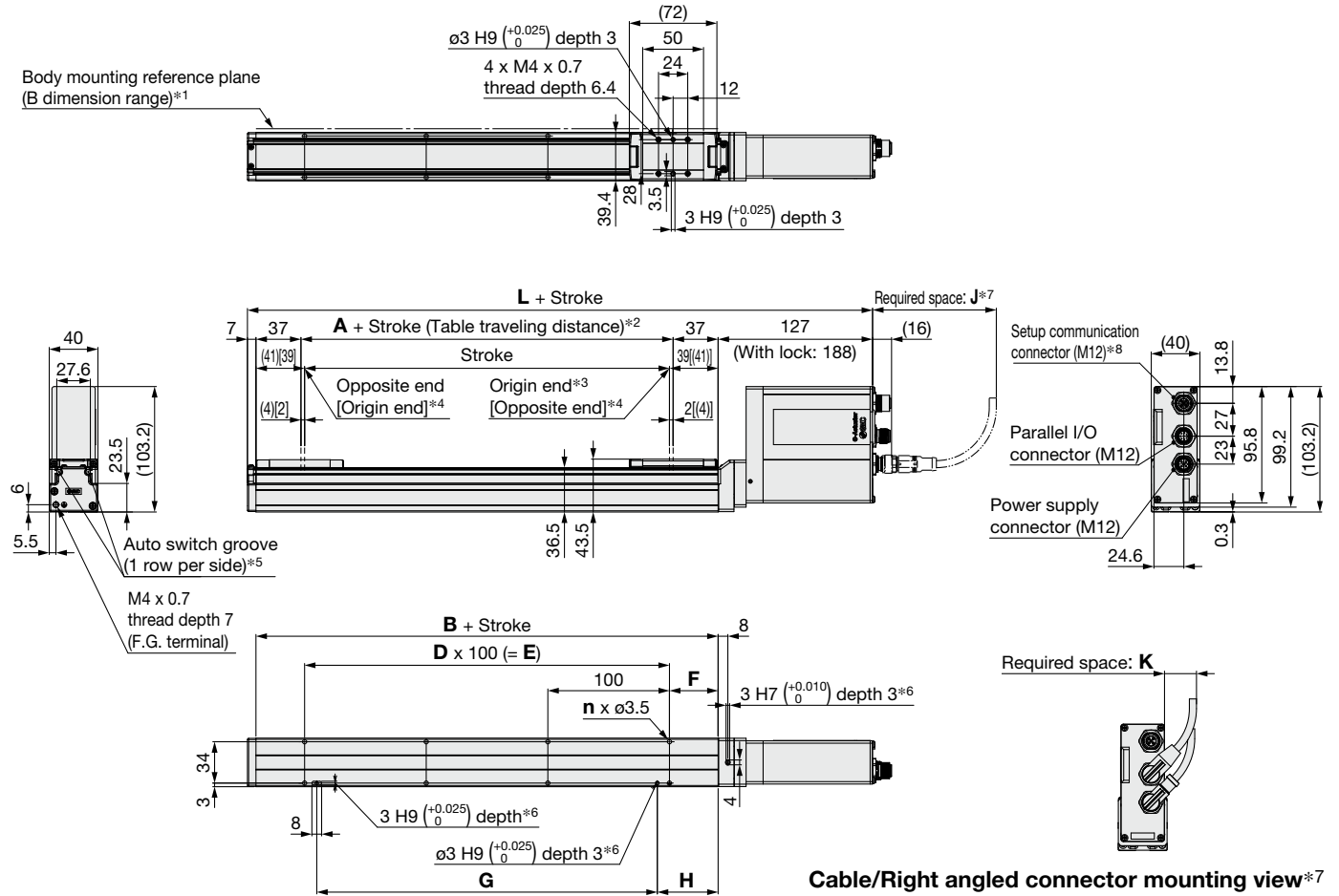

Cable/Right angled connector mounting view*7

Motor mounting position: Motor cover direction (Right angled cable)

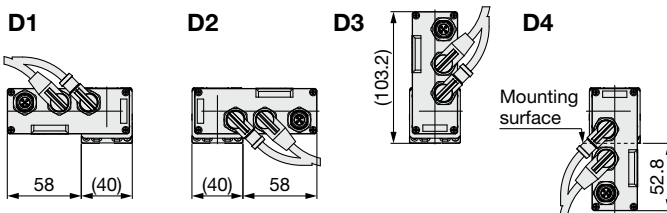

Required Space*7

Cable connector type	J	K
Straight	115	115
Right angled	50*9	25

*9 Secure a space of 100 mm or more to connect the communication cable for controller setting.

- *1 When mounting the actuator using the body mounting reference plane, set the height of the opposite surface or pin to be 3 mm or more. (Recommended height: 5 mm)
 In addition, be aware that surfaces other than the body mounting reference plane (B dimension range) may slightly protrude from the body mounting reference plane. Be sure to provide a clearance of 1 mm or more to avoid interference with workpieces, facilities, etc.
- *2 The distance the table moves according to movement instructions
 Make sure that workpieces mounted on the table do not interfere with other workpieces or the facilities around the table.
- *3 Indicates the factory default origin position (0 mm)
- *4 [] refers to when the rotation direction reference is changed.
- *5 The applicable auto switch (D-M9□) should be ordered separately.
- *6 When using the positioning pin holes on the bottom, use either the one on the body side or the one on the housing side.
- *7 The amount of space required to connect the various cables and mount the product
 Provide this amount of space for cable handling. Order the cable separately.
- *8 A female dustproof cap comes with the setup communication connector (M12).

Dimensions

Stroke [mm]	L		A	B	n	D	E	F	G	H
	Without lock	With lock								
50	214	275	6	80	4	—	—	15	80	25
100, 150					6	2	200	40	180	50
200, 250					8	3	300		280	
300, 350					10	4	400		380	
400, 450					12	5	500		480	
500										

Dimensions: In-line Motor

EQFS25H

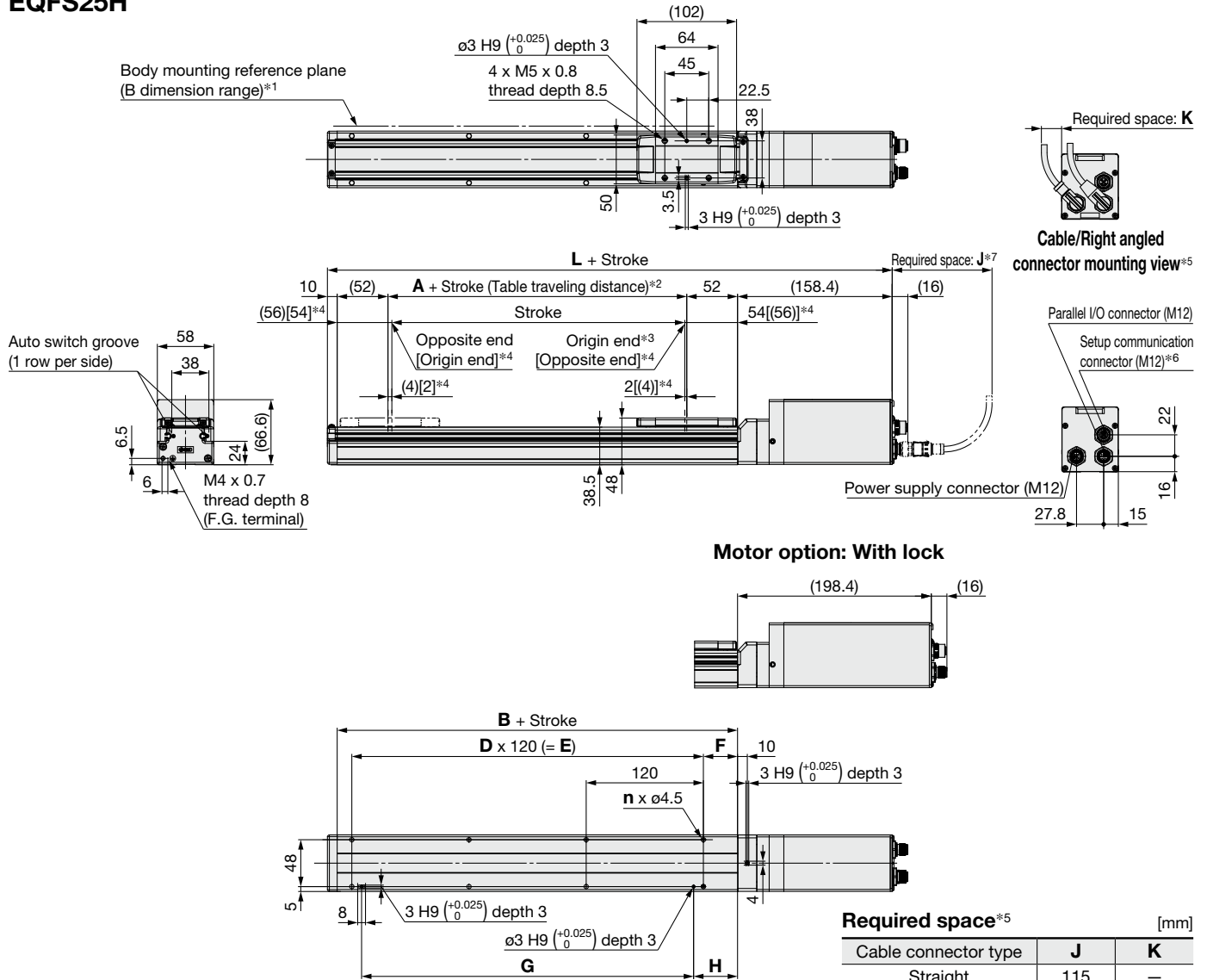

- *1 When mounting the actuator using the body mounting reference plane, set the height of the opposite surface or pin to be 3 mm or more. (Recommended height: 5 mm)
In addition, be aware that surfaces other than the body mounting reference plane (B dimension range) may slightly protrude from the body mounting reference plane. Be sure to provide a clearance of 1 mm or more to avoid interference with workpieces, facilities, etc.
- *2 The distance the table moves according to movement instructions
Make sure that workpieces mounted on the table do not interfere with other workpieces or the facilities around the table.
- *3 Indicates the factory default origin position (0 mm)
- *4 [] refers to when the rotation direction reference is changed.
- *5 The amount of space required to connect the various cables and mount the product
Provide this amount of space for cable handling. Order the cable separately.
- *6 A female dustproof cap comes with the setup communication connector (M12).
- *7 The applicable auto switch (D-M9□) should be ordered separately.
- * When using the positioning pin holes on the bottom, use either the one on the body side or the one on the housing side.

Dimensions

Stroke [mm]	L		A	B	n	D	E	F	G	H
	Without lock	With lock								
50	278.4	318.4	6	110	4	—	—	20	100	30
100, 150					6	2	240		220	
200, 250					8	3	360		340	
300, 350, 400					10	4	480		460	
450, 500					12	5	600		580	
550, 600, 650					14	6	720		700	
700, 750					16	7	840		820	

Model Selection
 EQFS□H Series
 EQY□H Series
 EQYG□H Series
 Auto Switch
 Electric Specifications
 Wiring Examples
 Options

Dimensions: In-line Motor

EQFS32H

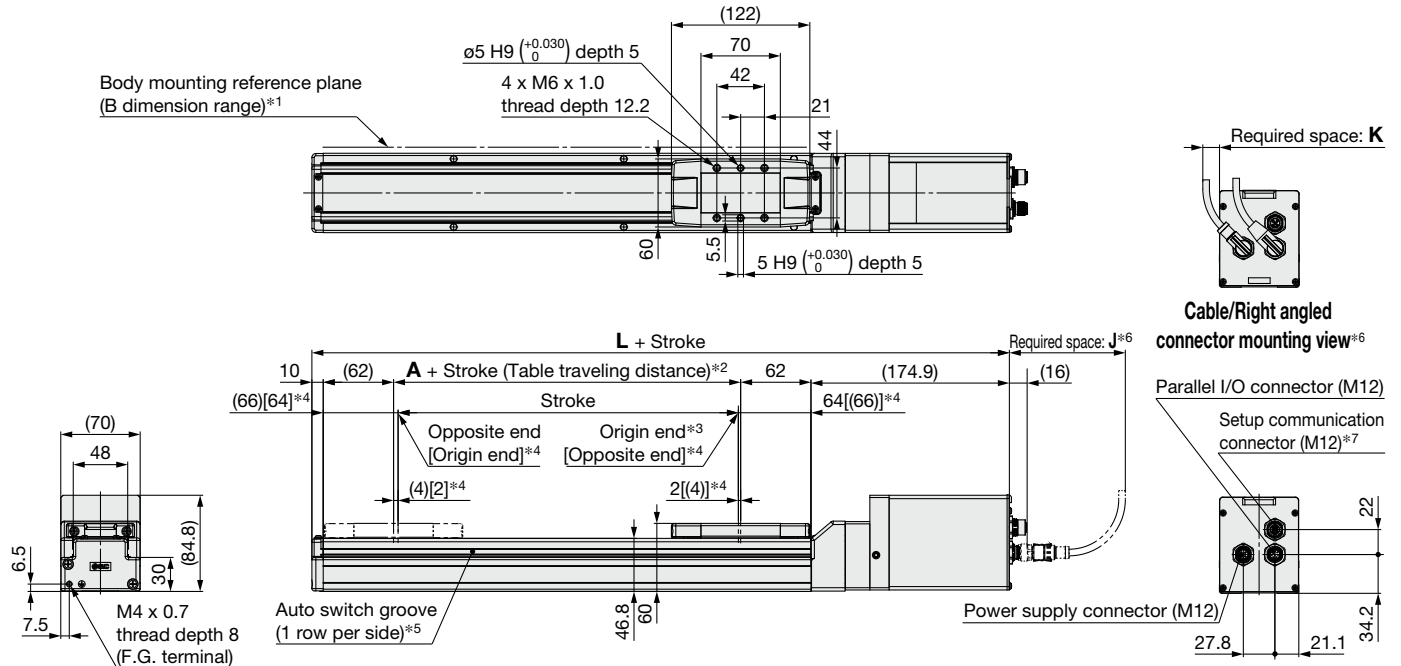

Motor option: With lock

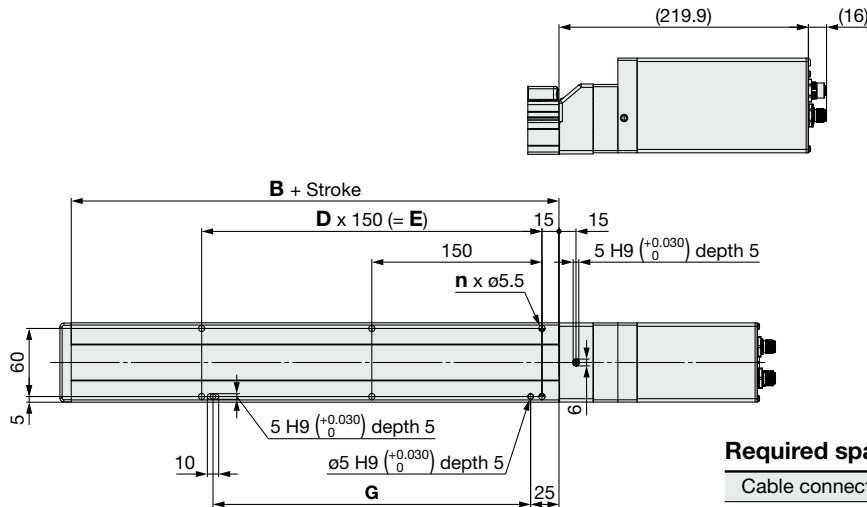

Required space*6 [mm]

Cable connector type	J	K
Straight	115	—
Right angled	50*8	20

*8 Secure a space of 100 mm or more to connect the communication cable for controller setting.

- *1 When mounting the actuator using the body mounting reference plane, set the height of the opposite surface or pin to be 3 mm or more. (Recommended height: 5 mm)
In addition, be aware that surfaces other than the body mounting reference plane (B dimension range) may slightly protrude from the body mounting reference plane. Be sure to provide a clearance of 1 mm or more to avoid interference with workpieces, facilities, etc.
- *2 The distance the table moves according to movement instructions
Make sure that workpieces mounted on the table do not interfere with other workpieces or the facilities around the table.
- *3 Indicates the factory default origin position (0 mm)
- *4 [] refers to when the rotation direction reference is changed.
- *5 The applicable auto switch (D-M9□) should be ordered separately.
- *6 The amount of space required to connect the various cables and mount the product
Provide this amount of space for cable handling. Order the cable separately.
- *7 A female dustproof cap comes with the setup communication connector (M12).
- * A switch spacer (BM3-016) is required to secure auto switches. Please order it separately.
- * When using the positioning pin holes on the bottom, use either the one on the body side or the one on the housing side.

Dimensions [mm]

Stroke [mm]	L		A	B	n	D	E	G
	Without lock	With lock						
50, 100, 150	314.9	359.9	6	130	4	—	—	130
200, 250, 300					6	2	300	280
350, 400, 450					8	3	450	430
500, 550, 600					10	4	600	580
650, 700, 750					12	5	750	730
800, 850, 900					14	6	900	880
950, 1000				16	7	1050	1030	

Dimensions: In-line Motor

EQFS40H

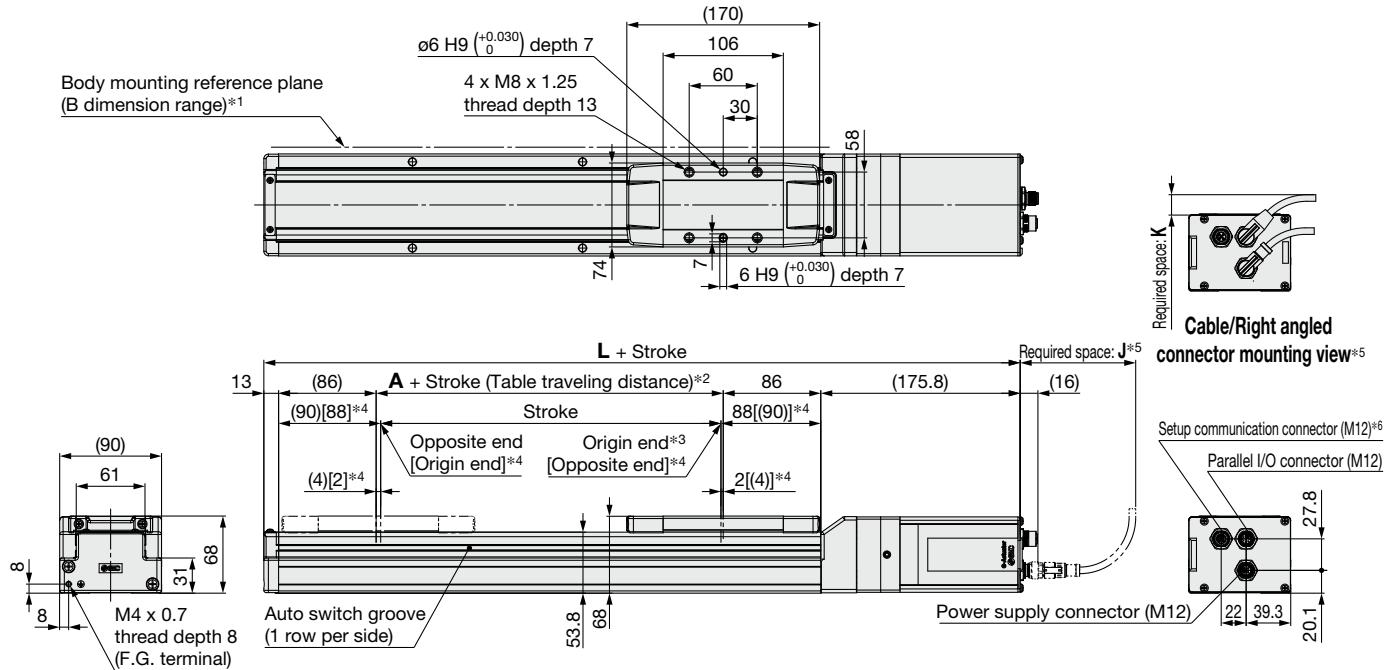

Motor option: With lock

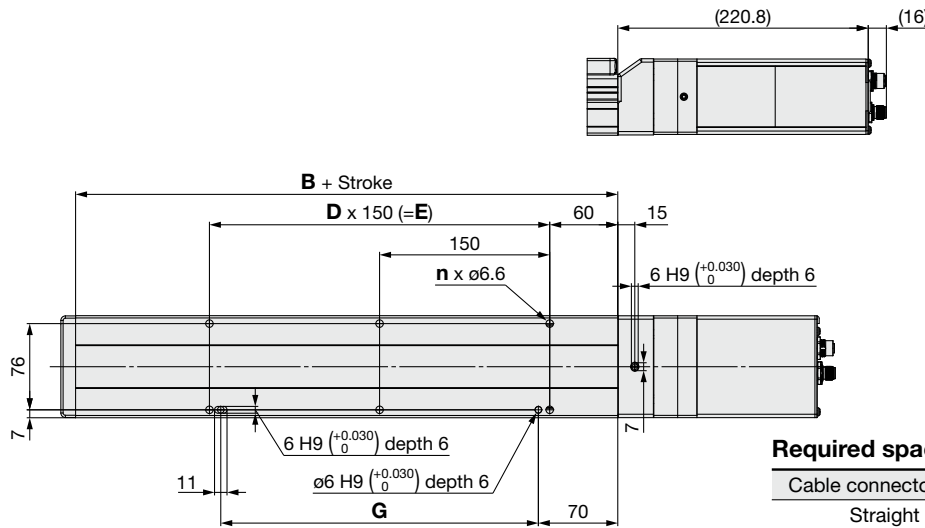

Required space*5 [mm]

Cable connector type	J	K
Straight	115	—
Right angled	50*7	20

*7 Secure a space of 100 mm or more to connect the communication cable for controller setting.

- *1 When mounting the actuator using the body mounting reference plane, set the height of the opposite surface or pin to be 3 mm or more. (Recommended height: 5 mm)
In addition, be aware that surfaces other than the body mounting reference plane (B dimension range) may slightly protrude from the body mounting reference plane. Be sure to provide a clearance of 1 mm or more to avoid interference with workpieces, facilities, etc.
- *2 The distance the table moves according to movement instructions
Make sure that workpieces mounted on the table do not interfere with other workpieces or the facilities around the table.
- *3 Indicates the factory default origin position (0 mm)
- *4 [] refers to when the rotation direction reference is changed.
- *5 The amount of space required to connect the various cables and mount the product
Provide this amount of space for cable handling.
Order the cable separately.
- *6 A female dustproof cap comes with the setup communication connector (M12).
* The applicable auto switch (D-M9□) should be ordered separately.
* A switch spacer (BMY3-016) is required to secure auto switches. Please order it separately.
* When using the positioning pin holes on the bottom, use either the one on the body side or the one on the housing side.

Dimensions

Stroke [mm]	L		A	B	n	D	E	G
	Without lock	With lock						
150	366.8	411.8	6	178	4	—	—	130
200, 250, 300					6	2	300	280
350, 400, 450					8	3	450	430
500, 550, 600					10	4	600	580
650, 700, 750					12	5	750	730
800, 850, 900					14	6	900	880
950, 1000					16	7	1050	1030
1100, 1200					18	8	1200	1180

Dimensions: Right/Left Side Parallel Motor

EQFS16RH

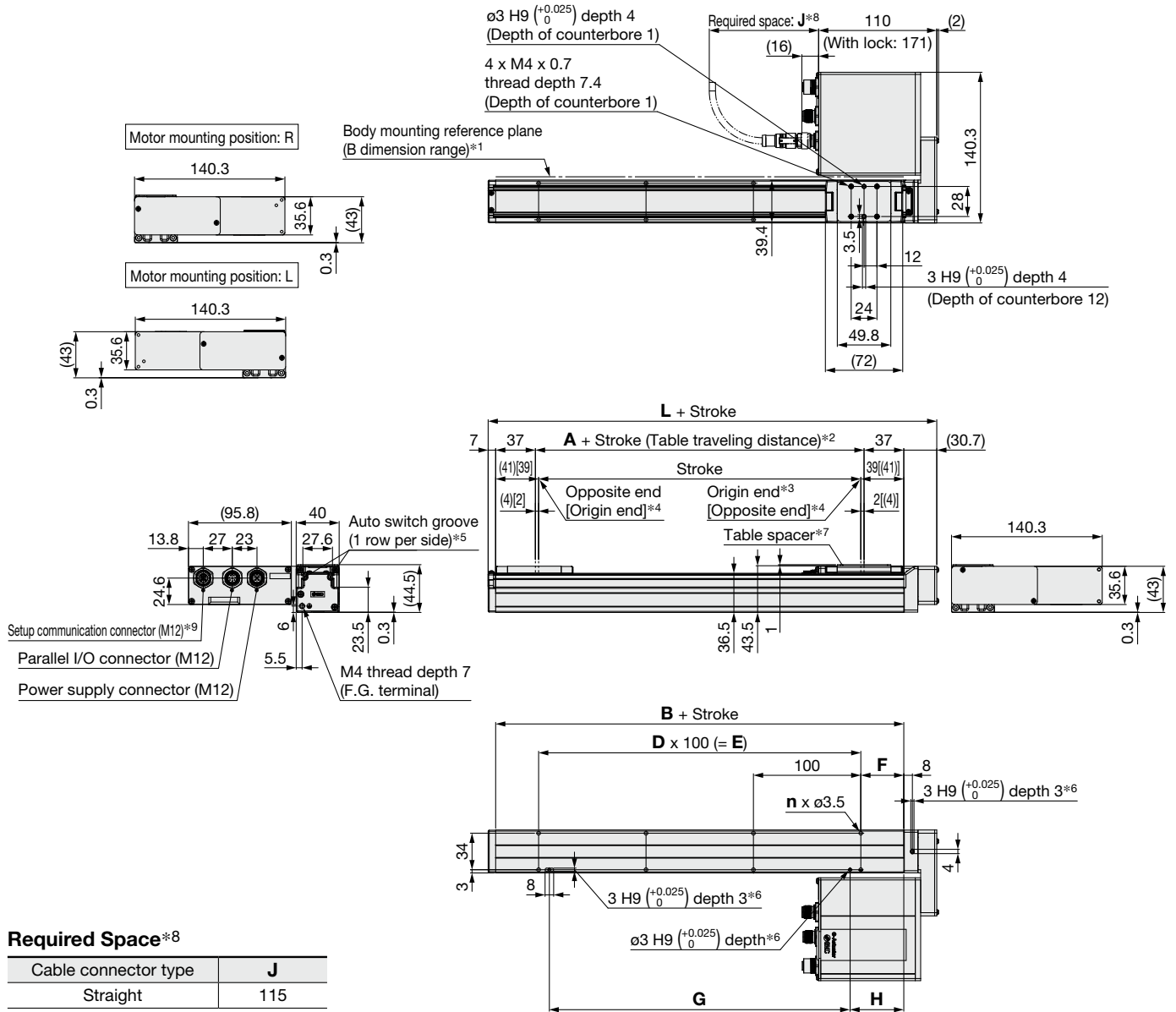

Required Space*8

Cable connector type	J
Straight	115

* The right angled type connector cannot be used.

- *1 When mounting the actuator using the body mounting reference plane, set the height of the opposite surface or pin to be 3 mm or more. (Recommended height: 5 mm)
 In addition, be aware that surfaces other than the body mounting reference plane (B dimension range) may slightly protrude from the body mounting reference plane. Be sure to provide a clearance of 1 mm or more to avoid interference with workpieces, facilities, etc.
- *2 The distance the table moves according to movement instructions
 Make sure that workpieces mounted on the table do not interfere with other workpieces or the facilities around the table.
- *3 Indicates the factory default origin position (0 mm)
- *4 [] refers to when the rotation direction reference is changed.
- *5 The applicable auto switch (D-M9□) should be ordered separately.
- *6 When using the positioning pin holes on the bottom, use either the one on the body side or the one on the housing side.
- *7 The table spacer is shipped together with the product but does not come assembled.
- *8 The amount of space required to connect the various cables and mount the product
 Provide this amount of space for cable handling. Order the cable separately.
- *9 A female dustproof cap comes with the setup communication connector (M12).

Dimensions

Stroke [mm]	L	A	B	n	D	E	F	G	H
50	117.7	6	90	4	—	—	15	80	25
100, 150				6	2	200	40	180	50
200, 250				8	3	300		280	
300, 350				10	4	400		380	
400, 450				12	5	500		480	
500									

Dimensions: Right/Left Side Parallel Motor

EQFS25RH

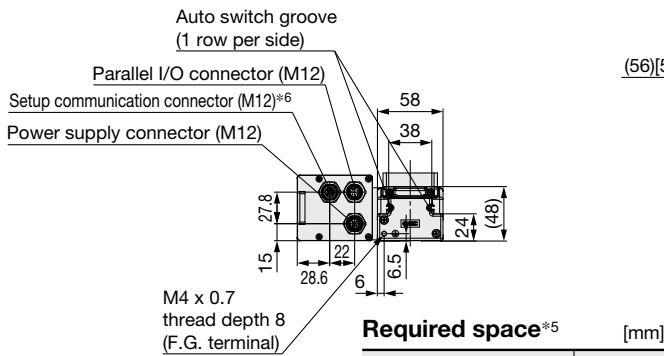
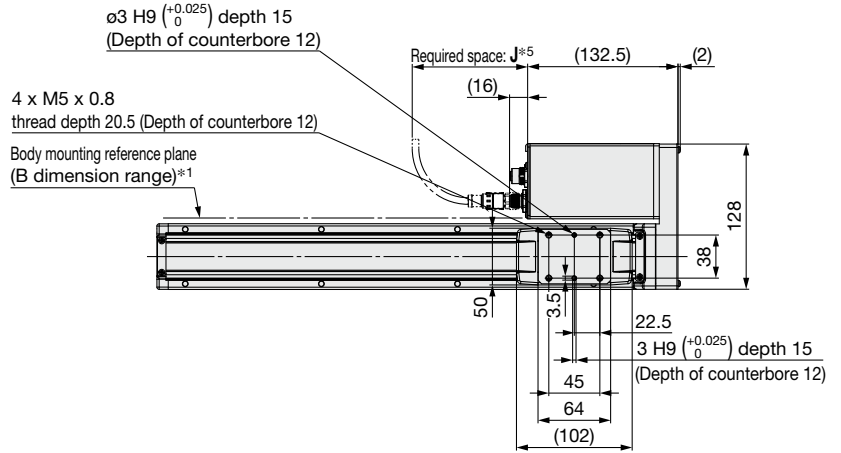
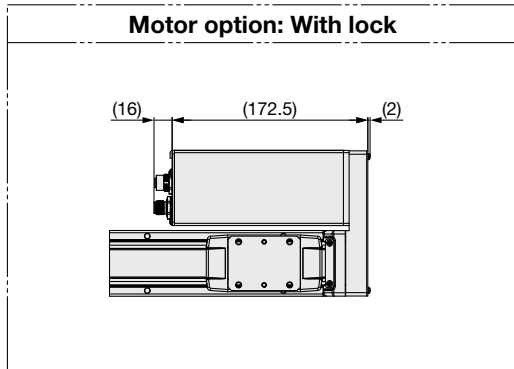

Required space*5 [mm]

Cable connector type	J
Straight	115

* The right angled type connector cannot be used.

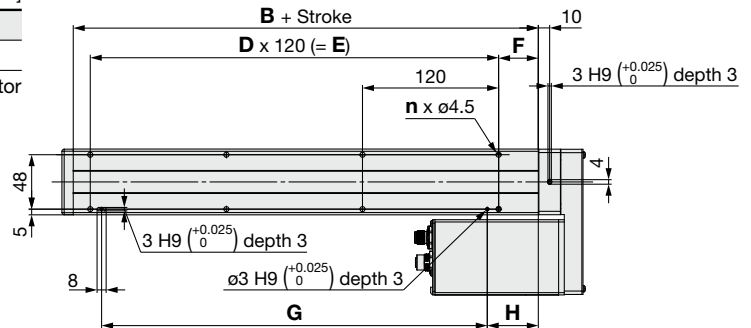
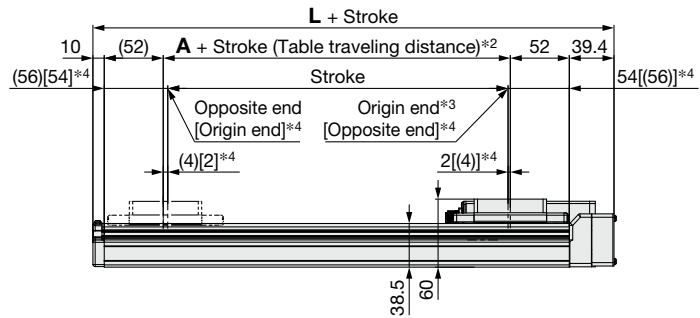
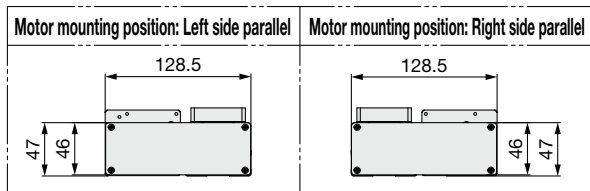

- *1 When mounting the actuator using the body mounting reference plane, set the height of the opposite surface or pin to be 3 mm or more. (Recommended height: 5 mm)
In addition, be aware that surfaces other than the body mounting reference plane (B dimension range) may slightly protrude from the body mounting reference plane. Be sure to provide a clearance of 1 mm or more to avoid interference with workpieces, facilities, etc.
- *2 The distance the table moves according to movement instructions
Make sure that workpieces mounted on the table do not interfere with other workpieces or the facilities around the table.
- *3 Indicates the factory default origin position (0 mm)
- *4 [] refers to when the rotation direction reference is changed.
- *5 The amount of space required to connect the various cables and mount the product
Provide this amount of space for cable handling. Order the cable separately.
- *6 A female dustproof cap comes with the setup communication connector (M12).
- * The applicable auto switch (D-M9□) should be ordered separately.
- * When using the positioning pin holes on the bottom, use either the one on the body side or the one on the housing side.
- * The table spacer is shipped together with the product but does not come assembled.

Dimensions

Stroke [mm]	L	A	B	n	D	E	F	G	H
50	159.4	6	110	4	—	—	20	100	30
100, 150				6	2	240	35	220	45
200, 250				8	3	360		340	
300, 350, 400				10	4	480		460	
450, 500				12	5	600		580	
550, 600, 650				14	6	720		700	
700, 750				16	7	840		820	
800									

Model Selection
 EQFS□H Series
 EQY□H Series
 EQYG□H Series
 Auto Switch
 Electric Specifications
 Wiring Examples
 Options

Dimensions: Right/Left Side Parallel Motor

EQFS32RH

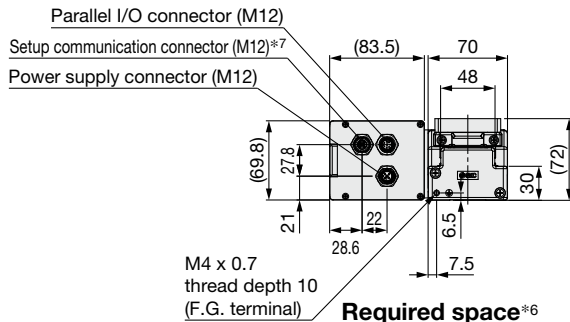
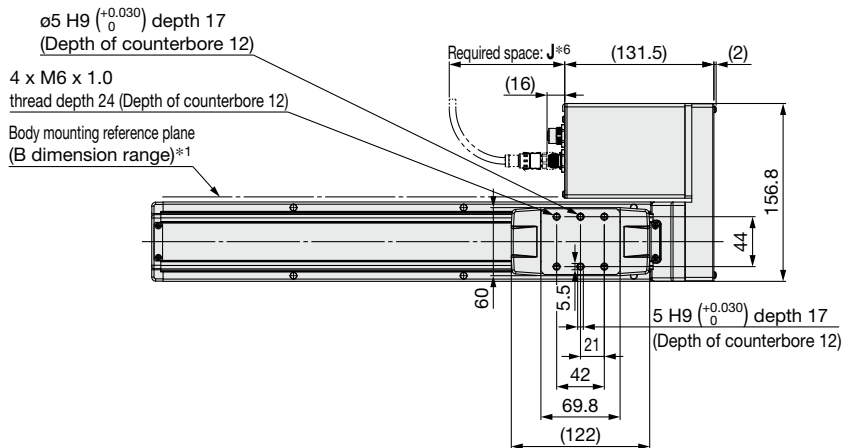
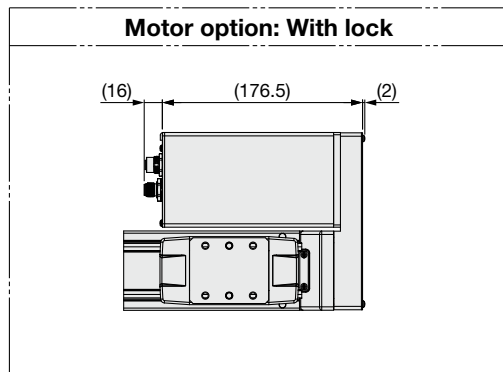

Required space*6 [mm]

Cable connector type	J
Straight	115

* The right angled type connector cannot be used.

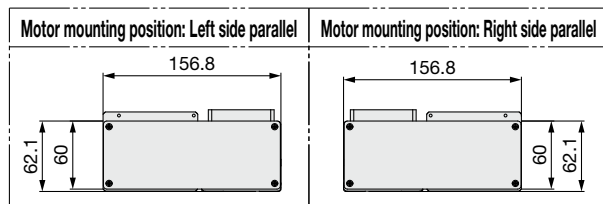
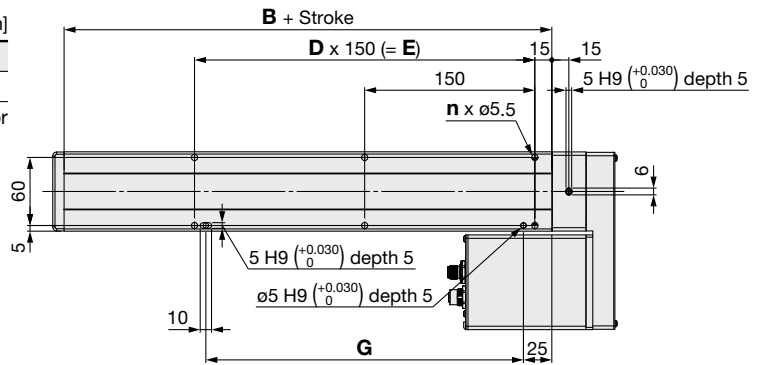
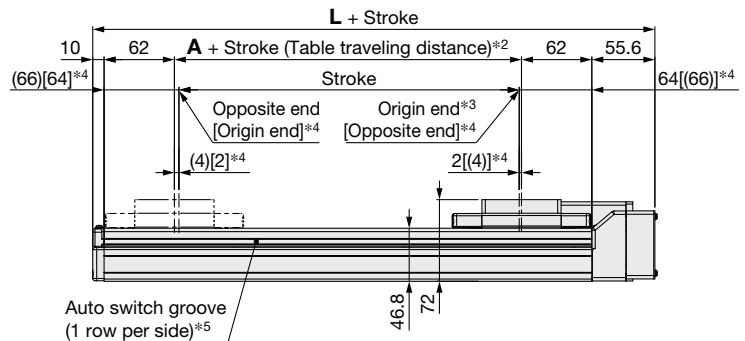

- *1 When mounting the actuator using the body mounting reference plane, set the height of the opposite surface or pin to be 3 mm or more. (Recommended height: 5 mm)
In addition, be aware that surfaces other than the body mounting reference plane (B dimension range) may slightly protrude from the body mounting reference plane. Be sure to provide a clearance of 1 mm or more to avoid interference with workpieces, facilities, etc.
- *2 The distance the table moves according to movement instructions
Make sure that workpieces mounted on the table do not interfere with other workpieces or the facilities around the table.
- *3 Indicates the factory default origin position (0 mm)
- *4 [] refers to when the rotation direction reference is changed.
- *5 The applicable auto switch (D-M9□) should be ordered separately.
- *6 The amount of space required to connect the various cables and mount the product
Provide this amount of space for cable handling. Order the cable separately.
- *7 A female dustproof cap comes with the setup communication connector (M12).
- * A switch spacer (BMY3-016) is required to secure auto switches. Please order it separately.
- * When using the positioning pin holes on the bottom, use either the one on the body side or the one on the housing side.
- * The table spacer is shipped together with the product but does not come assembled.

Dimensions

Stroke [mm]	L	A	B	n	D	E	G
50, 100, 150	195.6	6	130	4	—	—	130
200, 250, 300				6	2	300	280
350, 400, 450				8	3	450	430
500, 550, 600				10	4	600	580
650, 700, 750				12	5	750	730
800, 850, 900				14	6	900	880
950, 1000				16	7	1050	1030

Dimensions: Right/Left Side Parallel Motor

EQFS40RH

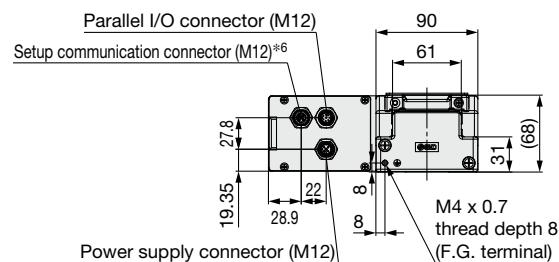
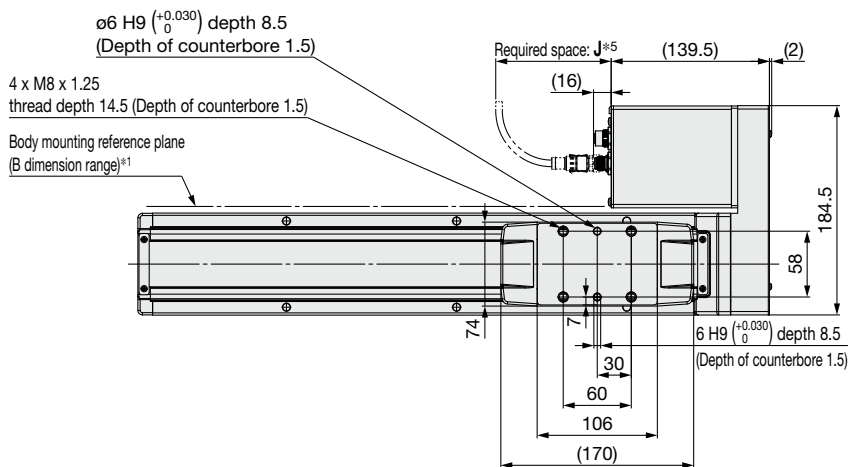
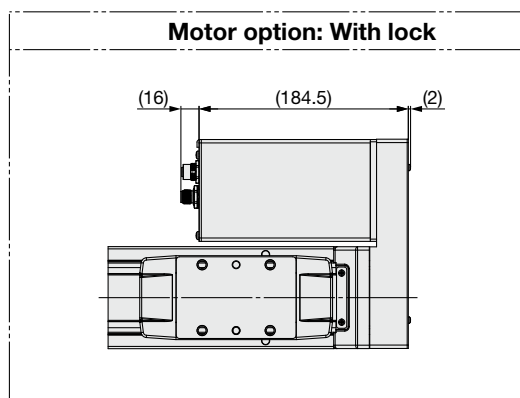

Required space*5 [mm]

Cable connector type	J
Straight	115

* The right angled type connector cannot be used.

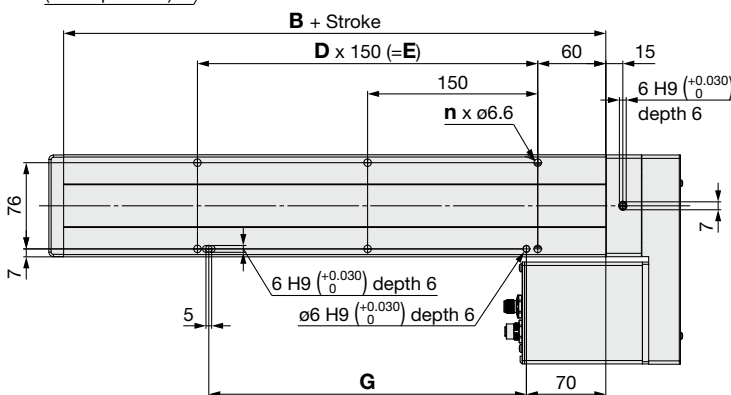
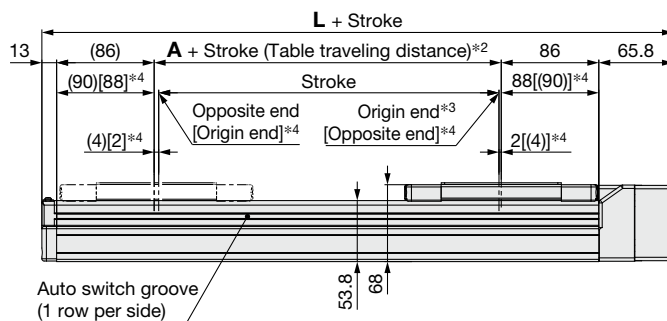
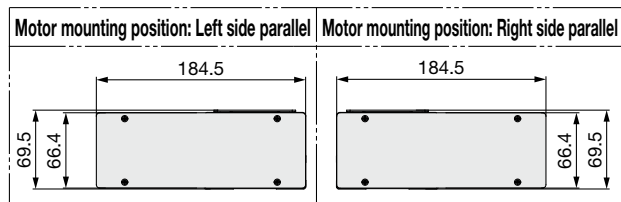

- *1 When mounting the actuator using the body mounting reference plane, set the height of the opposite surface or pin to be 3 mm or more. (Recommended height: 5 mm) In addition, be aware that surfaces other than the body mounting reference plane (B dimension range) may slightly protrude from the body mounting reference plane. Be sure to provide a clearance of 1 mm or more to avoid interference with workpieces, facilities, etc.
- *2 The distance the table moves according to movement instructions. Make sure that workpieces mounted on the table do not interfere with other workpieces or the facilities around the table.
- *3 Indicates the factory default origin position (0 mm)
- *4 [] refers to when the rotation direction reference is changed.
- *5 The amount of space required to connect the various cables and mount the product. Provide this amount of space for cable handling. Order the cable separately.
- *6 A female dustproof cap comes with the setup communication connector (M12).
- * The applicable auto switch (D-M9□) should be ordered separately.
- * A switch spacer (BMY3-016) is required to secure auto switches. Please order it separately.
- * When using the positioning pin holes on the bottom, use either the one on the body side or the one on the housing side.
- * The table spacer is shipped together with the product but does not come assembled.

Stroke [mm]	L	A	B	n	D	E	G
150	256.8	6	178	4	—	—	130
200, 250, 300				6	2	300	280
350, 400, 450				8	3	450	430
500, 550, 600				10	4	600	580
650, 700, 750				12	5	750	730
800, 850, 900				14	6	900	880
950, 1000				16	7	1050	1030
1100, 1200				18	8	1200	1180

Model Selection
 EQFS□H Series
 EQY□H Series
 EQYG□H Series
 Auto Switch
 Electric Specifications
 Wiring Examples
 Options

Slider Type/EQFS□H Series Auto Switch Mounting

Auto Switch Proper Mounting Position

Applicable auto switch: D-M9□, D-M9□E(V), D-M9□W

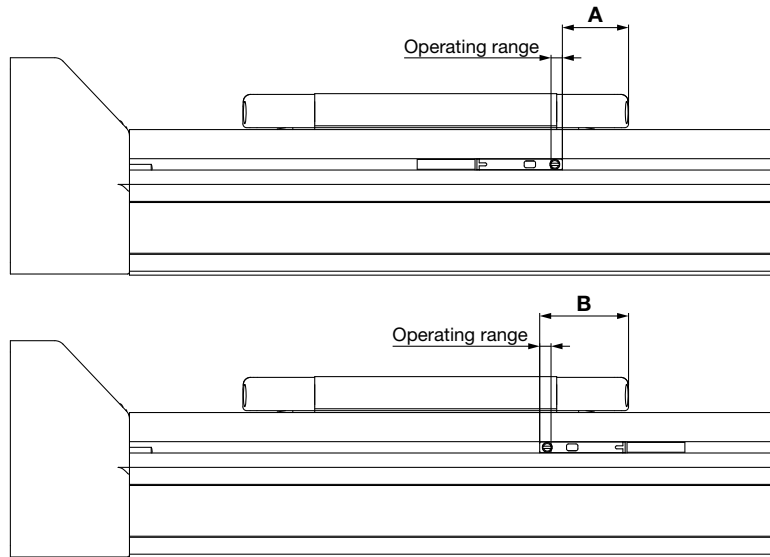

Size	A	B	Operating range
16	12.5	24.5	3.0
25	17.5	23.5	3.0
32	26.3	32.3	3.4
40	32.2	38.2	3.6

- * The operating range is a guideline including hysteresis, not meant to be guaranteed. There may be large variations depending on the ambient environment.
- * Adjust the auto switch after confirming the operating conditions in the actual setting.

Auto Switch Mounting

EQFS16/25H

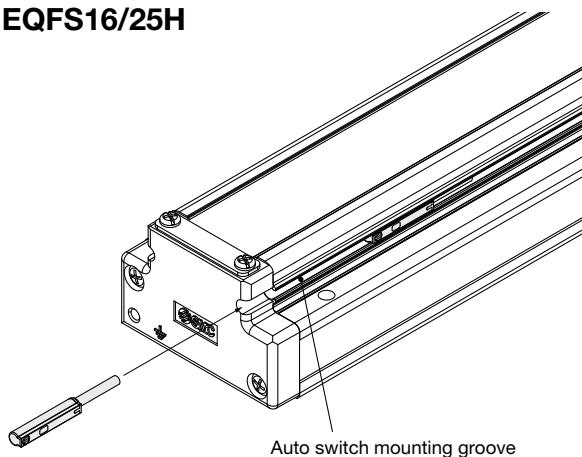

EQFS32/40H

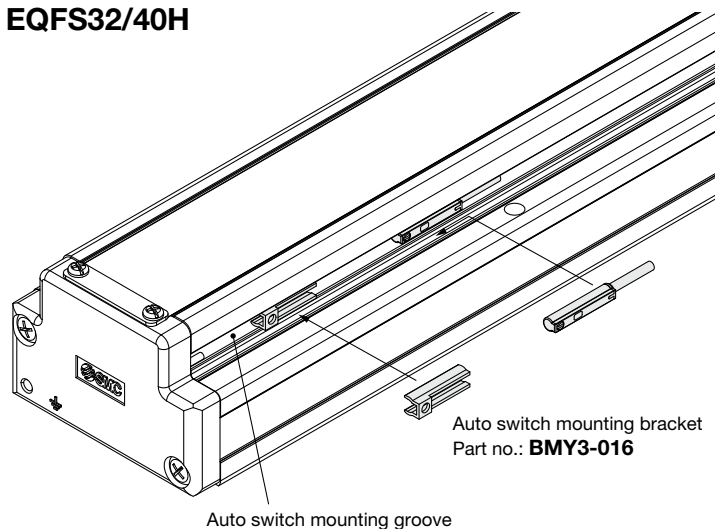

Tightening Torque for Auto Switch Mounting Screw [N·m]

Auto switch model	Tightening torque
D-M9□ D-M9□E(V) D-M9□W	0.1 to 0.15

- * When tightening the auto switch mounting screw (included with the auto switch), use a watchmaker's screwdriver with a handle diameter of 5 to 6 mm.
- * Prepare an auto switch mounting bracket (BMY3-016) when mounting the auto switch on to the EQFS32/40H.

Solid State Auto Switch Direct Mounting Type D-M9N/D-M9P/D-M9B

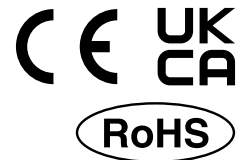

Refer to the SMC website for details on products that are compliant with international standards.

Grommet

- 2-wire load current is reduced (2.5 to 40 mA).
- Using flexible cable as standard spec.



Caution

Precautions

Fix the auto switch with the existing screw installed on the auto switch body. The auto switch may be damaged if a screw other than the one supplied is used.

Auto Switch Specifications

PLC: Programmable Logic Controller

D-M9□ (With indicator light)			
Auto switch model	D-M9N	D-M9P	D-M9B
Electrical entry direction	In-line		
Wiring type	3-wire		2-wire
Output type	NPN	PNP	—
Applicable load	IC circuit, Relay, PLC		24 VDC relay, PLC
Power supply voltage	5, 12, 24 VDC (4.5 to 28 V)		—
Current consumption	10 mA or less		—
Load voltage	28 VDC or less	—	24 VDC (10 to 28 VDC)
Load current	40 mA or less		2.5 to 40 mA
Internal voltage drop	0.8 V or less at 10 mA (2 V or less at 40 mA)		4 V or less
Leakage current	100 μA or less at 24 VDC		0.8 mA or less
Indicator light	Red LED illuminates when turned ON.		
Standard	CE/UKCA marking		

Oilproof Flexible Heavy-duty Lead Wire Specifications

Auto switch model		D-M9N	D-M9P	D-M9B
Sheath	Outside diameter [mm]	ø2.6		
	Number of cores	3 cores (Brown/Blue/Black)		2 cores (Brown/Blue)
Insulator	Outside diameter [mm]	ø0.88		
	Effective area [mm ²]	0.15		
Conductor	Strand diameter [mm]	ø0.05		
	Min. bending radius [mm] (Reference values)	17		

- * Refer to the **Web Catalog** for solid state auto switch common specifications.
- * Refer to the **Web Catalog** for lead wire lengths.

Weight

[g]

Auto switch model		D-M9N	D-M9P	D-M9B
Lead wire length	0.5 m (Nil)	8	7	7
	1 m (M)	14	13	13
	3 m (L)	41	38	38
	5 m (Z)	68	63	63

Dimensions

[mm]

D-M9□

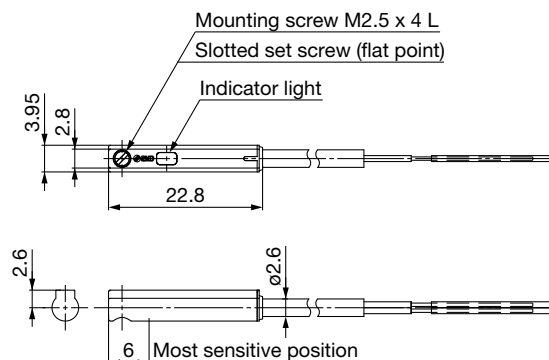

Normally Closed Solid State Auto Switch Direct Mounting Type D-M9NE(V)/D-M9PE(V)/D-M9BE(V)

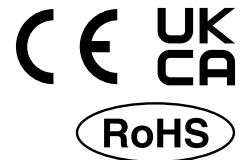

Refer to the SMC website for details on products that are compliant with international standards.

Auto Switch Specifications

PLC: Programmable Logic Controller

D-M9□E, D-M9□EV (With indicator light)						
Auto switch model	D-M9NE	D-M9NEV	D-M9PE	D-M9PEV	D-M9BE	D-M9BEV
Electrical entry direction	In-line	Perpendicular	In-line	Perpendicular	In-line	Perpendicular
Wiring type	3-wire				2-wire	
Output type	NPN		PNP		—	
Applicable load	IC circuit, Relay, PLC				24 VDC relay, PLC	
Power supply voltage	5, 12, 24 VDC (4.5 to 28 V)					
Current consumption	10 mA or less				—	
Load voltage	28 VDC or less		—		24 VDC (10 to 28 VDC)	
Load current	40 mA or less				2.5 to 40 mA	
Internal voltage drop	0.8 V or less at 10 mA (2 V or less at 40 mA)				4 V or less	
Leakage current	100 μA or less at 24 VDC				0.8 mA or less	
Indicator light	Red LED illuminates when turned ON.					
Standard	CE/UKCA marking					

Grommet

- Output signal turns on when no magnetic force is detected.
- Can be used for the actuator adopted by the solid state auto switch D-M9 series (excluding special order products)

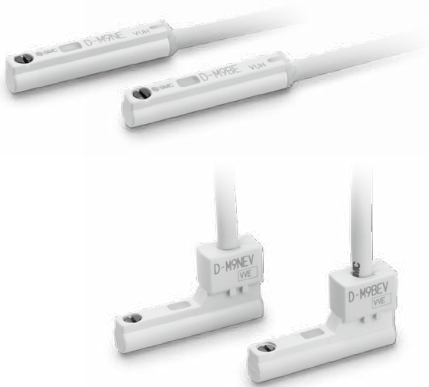

Oilproof Flexible Heavy-duty Lead Wire Specifications

Auto switch model		D-M9NE(V)	D-M9PE(V)	D-M9BE(V)
Sheath	Outside diameter [mm]	ø2.6		
Insulator	Number of cores	3 cores (Brown/Blue/Black)		2 cores (Brown/Blue)
	Outside diameter [mm]	ø0.88		
Conductor	Effective area [mm ²]	0.15		
	Strand diameter [mm]	ø0.05		
Min. bending radius [mm] (Reference values)		17		

- * Refer to the **Web Catalog** for solid state auto switch common specifications.
- * Refer to the **Web Catalog** for lead wire lengths.

Caution

Precautions

Fix the auto switch with the existing screw installed on the auto switch body. The auto switch may be damaged if a screw other than the one supplied is used.

Weight

[g]

Auto switch model		D-M9NE(V)	D-M9PE(V)	D-M9BE(V)
Lead wire length	0.5 m (Nil)	8	7	7
	1 m (M)*1	14	13	13
	3 m (L)	41	38	38
	5 m (Z)*1	68	63	63

*1 The 1 m and 5 m options are produced upon receipt of order.

Dimensions

[mm]

D-M9□E

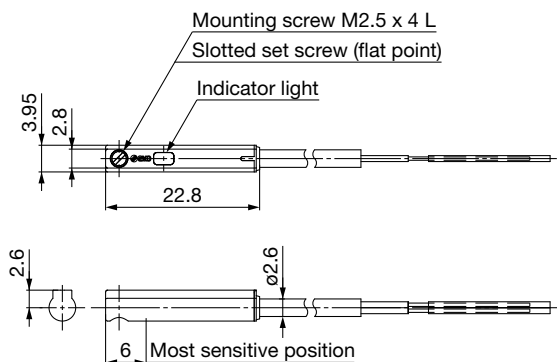

D-M9□EV

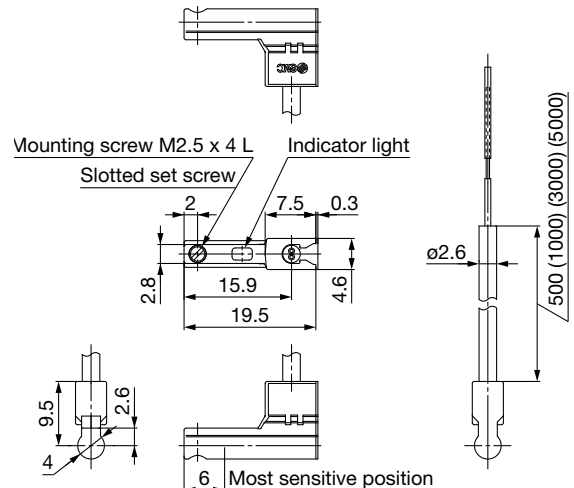

2-Color Indicator Solid State Auto Switch Direct Mounting Type D-M9NW/D-M9PW/D-M9BW



Refer to the SMC website for details on products that are compliant with international standards.

Grommet

- 2-wire load current is reduced (2.5 to 40 mA).
- Using flexible cable as standard spec.
- The proper operating range can be determined by the color of the light. (Red → Green ← Red)



Caution

Precautions

Fix the auto switch with the existing screw installed on the auto switch body. The auto switch may be damaged if a screw other than the one supplied is used.

Auto Switch Specifications

PLC: Programmable Logic Controller

D-M9□W (With indicator light)			
Auto switch model	D-M9NW	D-M9PW	D-M9BW
Electrical entry direction	In-line		
Wiring type	3-wire		2-wire
Output type	NPN	PNP	—
Applicable load	IC circuit, Relay, PLC		24 VDC relay, PLC
Power supply voltage	5, 12, 24 VDC (4.5 to 28 V)		—
Current consumption	10 mA or less		
Load voltage	28 VDC or less	—	24 VDC (10 to 28 VDC)
Load current	40 mA or less		2.5 to 40 mA
Internal voltage drop	0.8 V or less at 10 mA (2 V or less at 40 mA)		4 V or less
Leakage current	100 μA or less at 24 VDC		0.8 mA or less
Indicator light	Operating range Red LED illuminates. Proper operating range Green LED illuminates.		
Standard	CE/UKCA marking		

Oilproof Flexible Heavy-duty Lead Wire Specifications

Auto switch model		D-M9NW	D-M9PW	D-M9BW
Sheath	Outside diameter [mm]	ø2.6		
Insulator	Number of cores	3 cores (Brown/Blue/Black)		2 cores (Brown/Blue)
	Outside diameter [mm]	ø0.88		
Conductor	Effective area [mm ²]	0.15		
	Strand diameter [mm]	ø0.05		
Min. bending radius [mm] (Reference values)		17		

- * Refer to the **Web Catalog** for solid state auto switch common specifications.
- * Refer to the **Web Catalog** for lead wire lengths.

Weight

[g]

Auto switch model		D-M9NW	D-M9PW	D-M9BW
Lead wire length	0.5 m (Nil)	8	7	7
	1 m (M)	14	13	13
	3 m (L)	41	38	38
	5 m (Z)	68	63	63

Dimensions

[mm]

D-M9□W

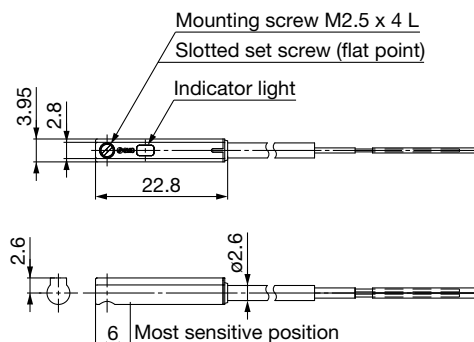

e-Actuator

Easy to Operate Integrated Controller / Rod Type

EQY□H Series

p. 35

Battery-less Absolute (Step Motor 24 VDC)

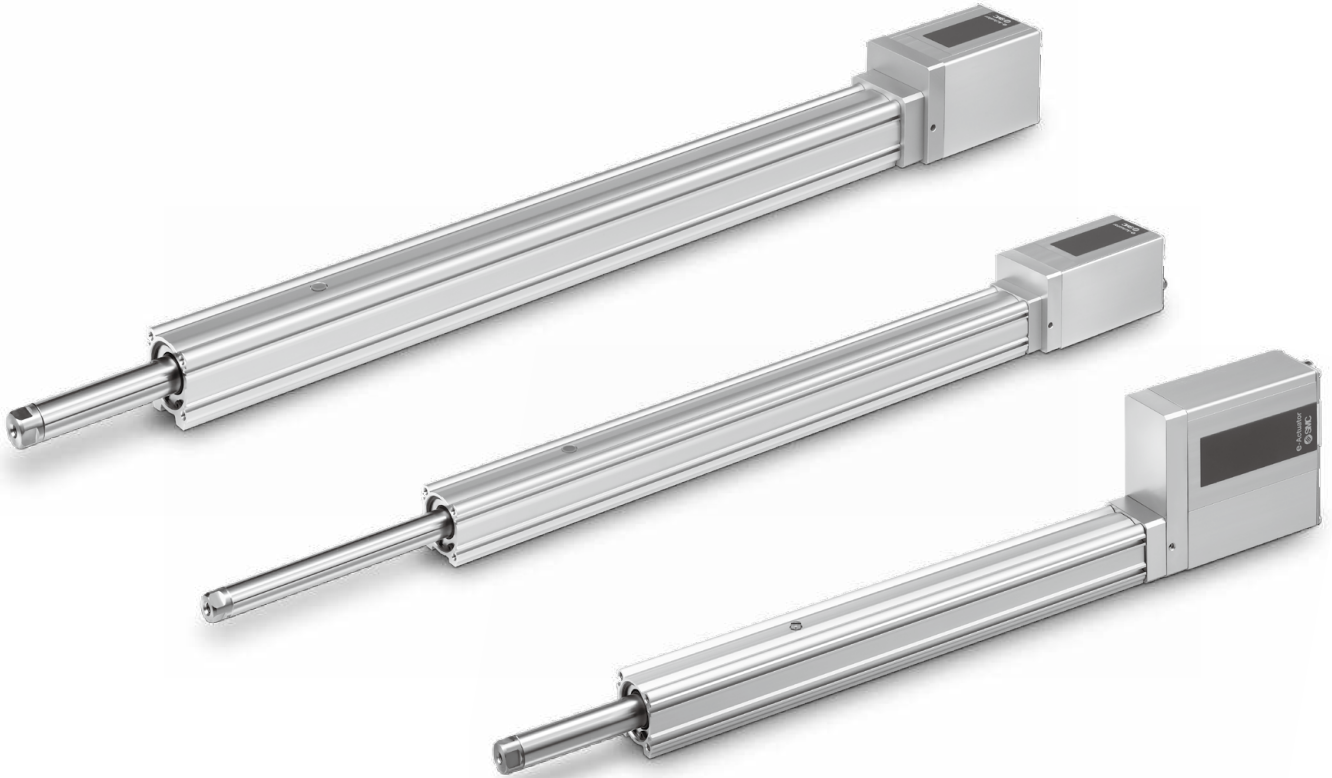

Model Selection

EQFS□H Series

EQY□H Series

EQYG□H Series

Auto Switch

Electric Specifications

Wiring Examples

Options

Model Selection

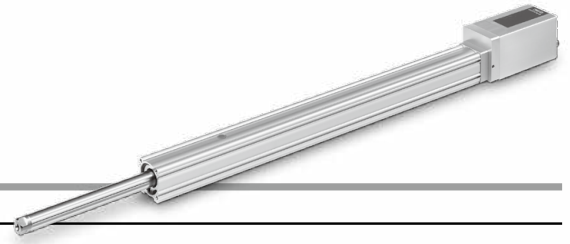

Selection Procedure

Positioning Control Selection Procedure

- Step 1** Check the work load–speed. (Vertical transfer) → **Step 2** Check the cycle time.

Selection Example

Operating conditions

- Workpiece mass: 10 [kg]
- Speed: 100 [mm/s]
- Acceleration/Deceleration: 5000 [mm/s²]
- Stroke: 200 [mm]
- Workpiece mounting condition: Vertical upward downward transfer

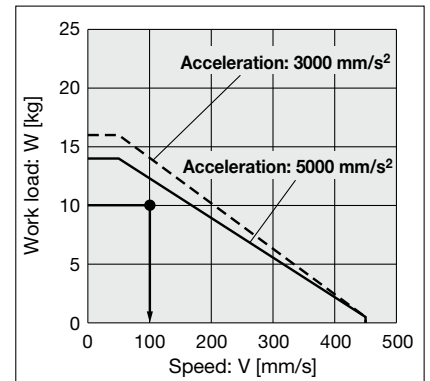

<Speed-Vertical work load graph>
(EQY25HB/Step motor)

Step 1 Check the work load–speed. <Speed-Vertical work load graph>

Select a model based on the workpiece mass and speed while referencing the speed–vertical work load graph.

Selection example) The **EQY25DHB-200** can be temporarily selected as a possible candidate based on the graph shown on the right side.

* It is necessary to mount a guide outside the actuator when used for horizontal transfer. When selecting the target model, refer to the horizontal work load in the specifications on page 42 and the precautions.

Step 2 Check the cycle time.

Calculate the cycle time using the following calculation method.

Cycle time:

T can be found from the following equation.

$$T = T1 + T2 + T3 + T4 \text{ [s]}$$

- T1: Acceleration time and T3: Deceleration time can be found by the following equation.

$$T1 = V/a1 \text{ [s]} \quad T3 = V/a2 \text{ [s]}$$

- T2: Constant speed time can be found from the following equation.

$$T2 = \frac{L - 0.5 \cdot V \cdot (T1 + T3)}{V} \text{ [s]}$$

- T4: Settling time varies depending on the conditions such as actuator types, load, and in position of the step data. Reference value for settling time: 0.15 s or less. The following value is used for this calculation.

$$T4 = 0.15 \text{ [s]}$$

Calculation example)

T1 to T4 can be calculated as follows.

$$T1 = V/a1 = 100/5000 = 0.02 \text{ [s]}, \quad T3 = V/a2 = 100/5000 = 0.02 \text{ [s]}$$

$$T2 = \frac{L - 0.5 \cdot V \cdot (T1 + T3)}{V} = \frac{200 - 0.5 \cdot 100 \cdot (0.02 + 0.02)}{100} = 1.98 \text{ [s]}$$

$$T4 = 0.15 \text{ [s]}$$

The cycle time can be found as follows.

$$T = T1 + T2 + T3 + T4 = 0.02 + 1.98 + 0.02 + 0.15 = 2.17 \text{ [s]}$$

Based on the above calculation result, the **EQY25HB-200** should be selected.

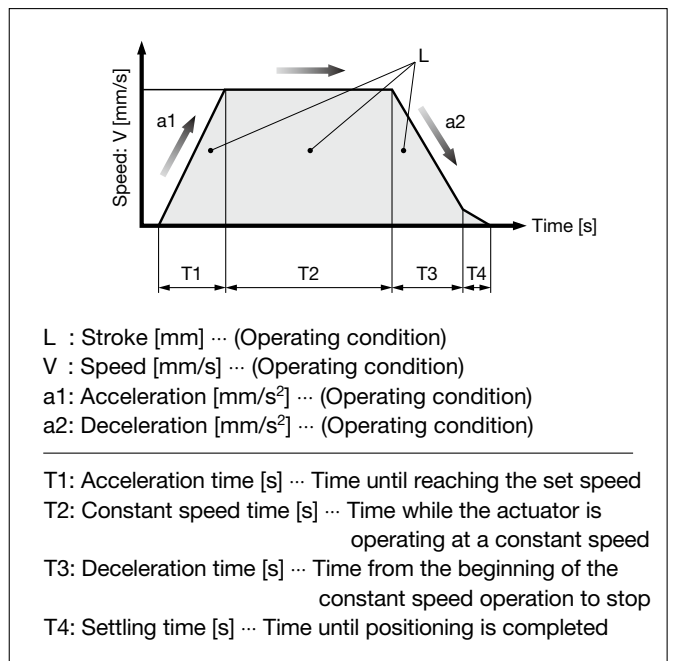

Selection Procedure

Pushing Control Selection Procedure



* The duty ratio is a ratio of the operation time in one cycle.

Selection Example

Operating conditions

- Mounting condition: Horizontal (pushing)
- Attachment weight: 0.2 [kg]
- Pushing force: 100 [N]
- Duty ratio: 15 [%]
- Speed: 100 [mm/s]
- Stroke: 200 [mm]

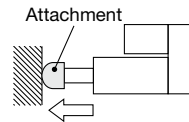

Step 1 Check the duty ratio.

<Conversion table of pushing force–duty ratio>

Select the [Pushing force] from the duty ratio while referencing the conversion table of pushing force–duty ratio.

Selection example)

Based on the table below,

- Duty ratio: 15 [%]

The pushing force set value will be 50 [%].

<Conversion table of pushing force–duty ratio>

(EQY25/Battery-less absolute)

Ambient temperature	Pushing force set value [%]	Duty ratio [%]	Continuous pushing time [min]
40°C or less	50 or less	100	—

* [Pushing force set value] is one of the step data input to the controller.

* [Continuous pushing time] is the time that the actuator can continuously keep pushing.

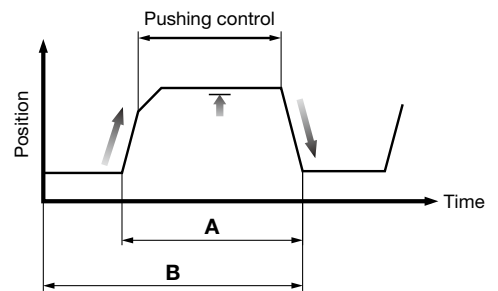

$$\text{Duty ratio} = A/B \times 100 \text{ [%]}$$

Step 2 Check the pushing force.

<Force conversion graph>

Select a model based on the pushing force set value and force while referencing the force conversion graph.

Selection example)

Based on the graph shown on the right side,

- Pushing force: 100 [N]
- Pushing force set value: 40 [%]

The **EQY25DHB** can be temporarily selected as a possible candidate.

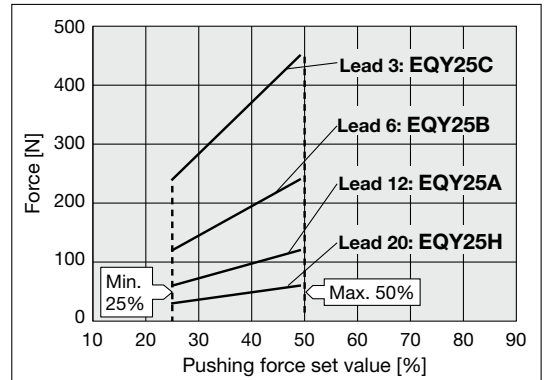

<Force conversion graph>
(EQY25□H/Step motor)

Step 3 Check the lateral load on the rod end.

<Graph of allowable lateral load on the rod end>

Confirm the allowable lateral load on the rod end of the actuator: EQY25, which has been selected temporarily while referencing the graph of allowable lateral load on the rod end.

Selection example)

Based on the graph shown on the right side,

- Attachment weight: 0.2 [kg] ≈ 2 [N]
- Product stroke: 200 [mm]

The lateral load on the rod end is in the allowable range.

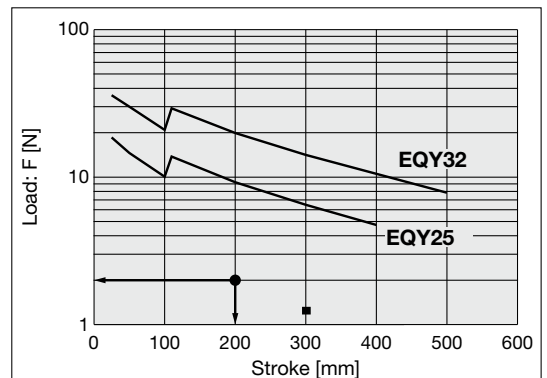

<Graph of allowable lateral load on the rod end>

Based on the above calculation result, the EQY25DHB-200 should be selected.

Speed-Work Load Graph (Guide)

* The following graphs show the values when the external guide is used together.

EQY16□HA

Horizontal/Lead 10

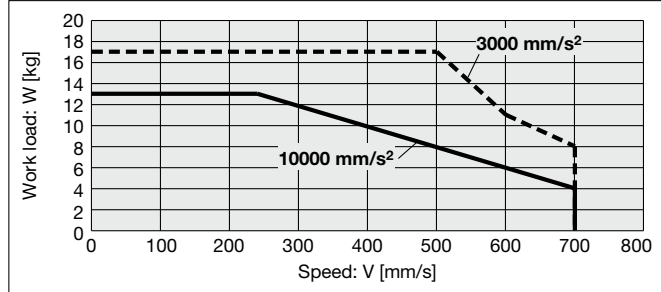

Vertical/Lead 10

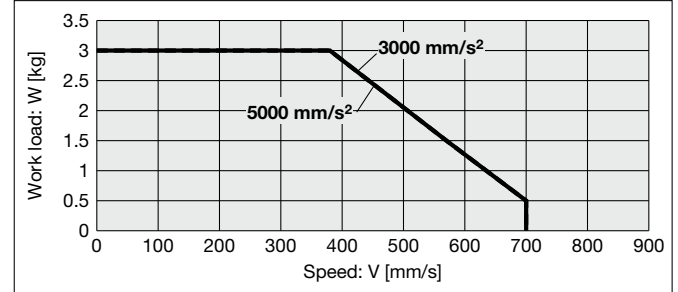

EQY16□HB

Horizontal/Lead 5

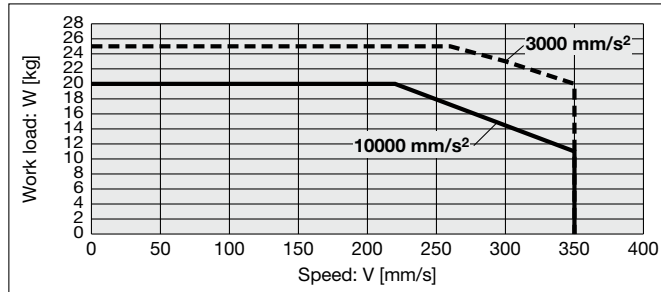

Vertical/Lead 5

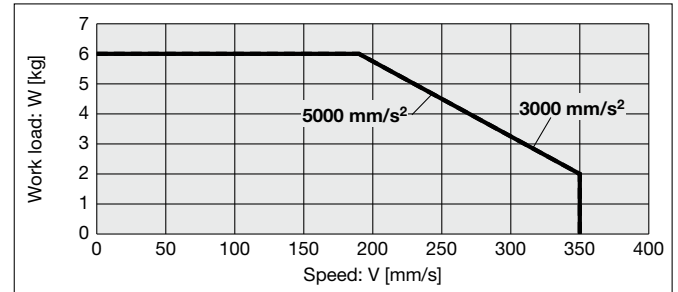

EQY16□HC

Horizontal/Lead 2.5

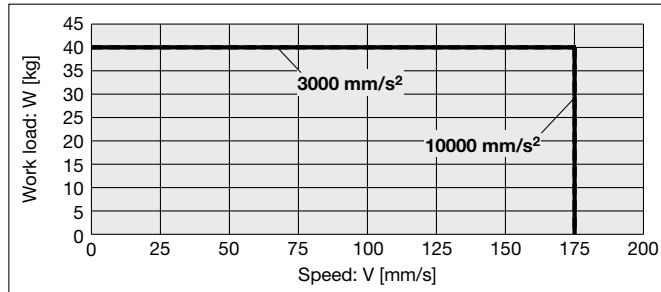

Vertical/Lead 2.5

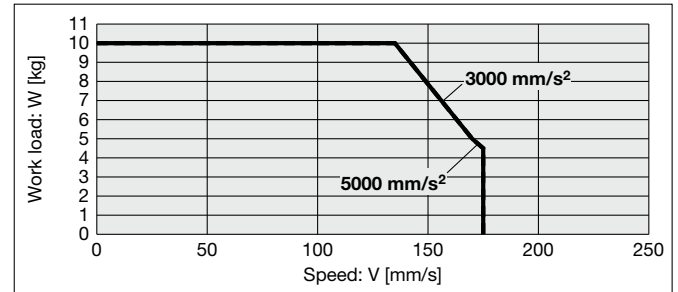

Speed-Work Load Graph (Guide)

* The following graphs show the values when the external guide is used together.

EQY25□HH

Horizontal/Lead 20

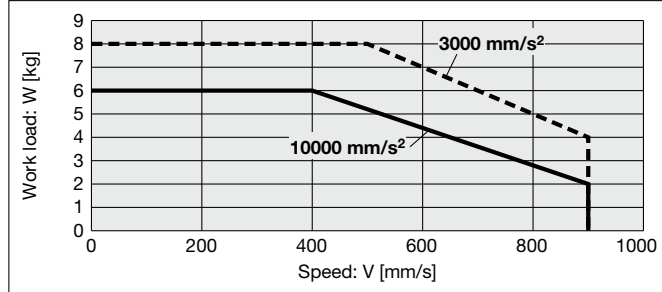

Vertical/Lead 20

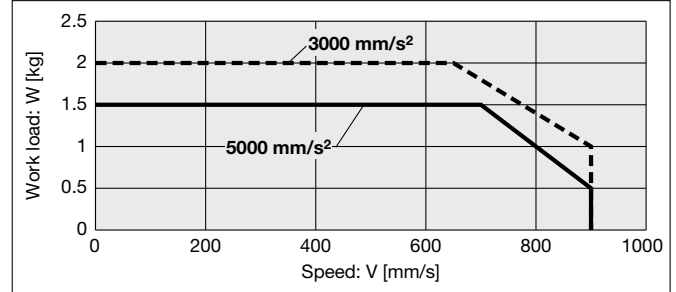

EQY25□HA

Horizontal/Lead 12

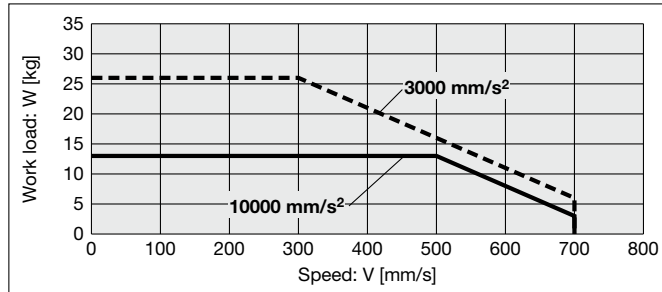

Vertical/Lead 12

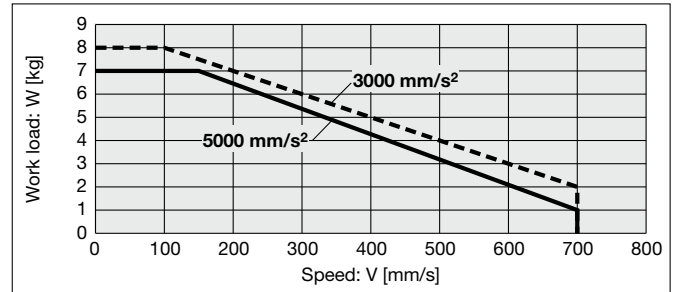

EQY25□HB

Horizontal/Lead 6

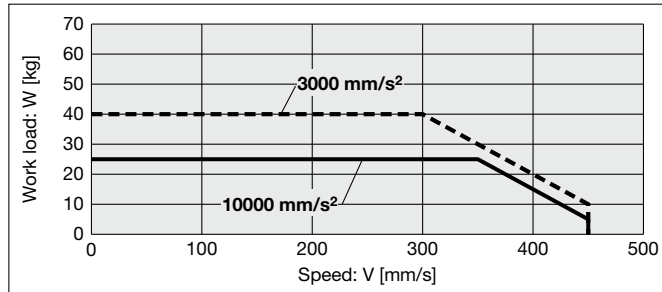

Vertical/Lead 6

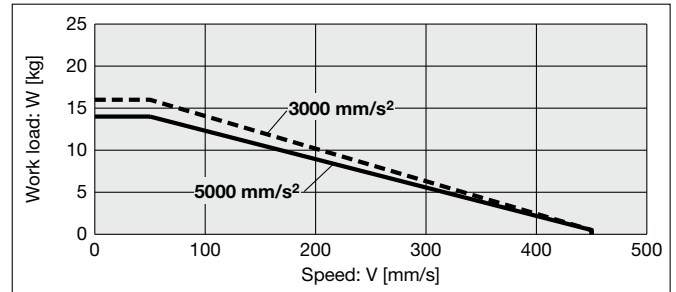

EQY25□HC

Horizontal/Lead 3

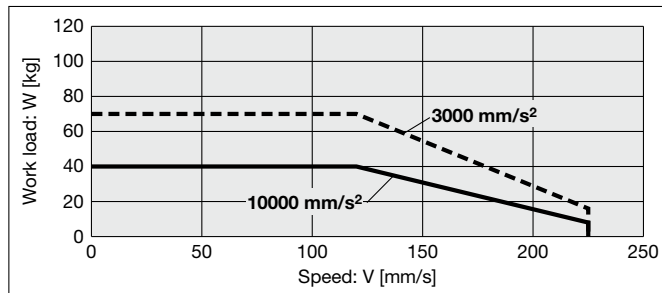

Vertical/Lead 3

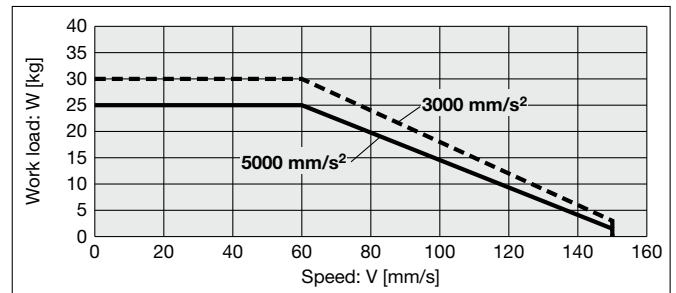

Model Selection
 EQFS□H Series
 EQY□H Series
 EQYG□H Series
 Auto Switch
 Electric Specifications
 Wiring Examples
 Options

Speed-Work Load Graph (Guide)

* The following graphs show the values when the external guide is used together.

EQY32□HH

Horizontal/Lead 24

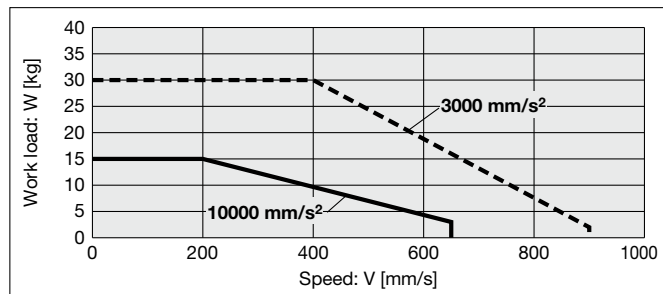

Vertical/Lead 24

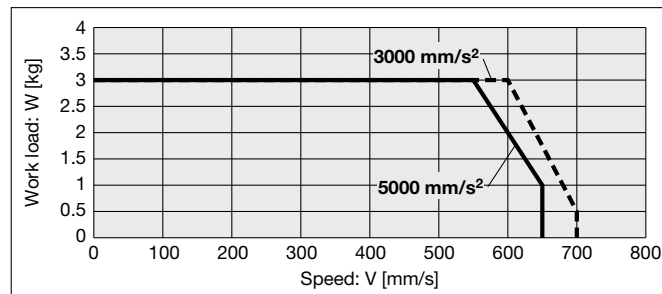

EQY32□HA

Horizontal/Lead 16

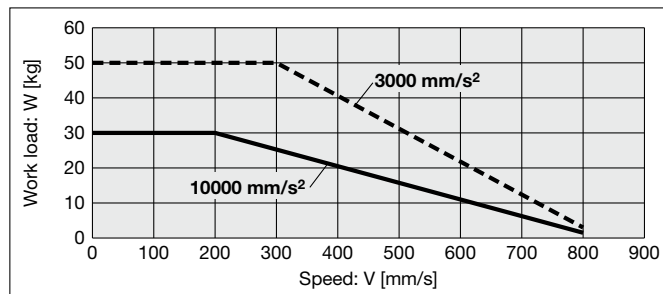

Vertical/Lead 16

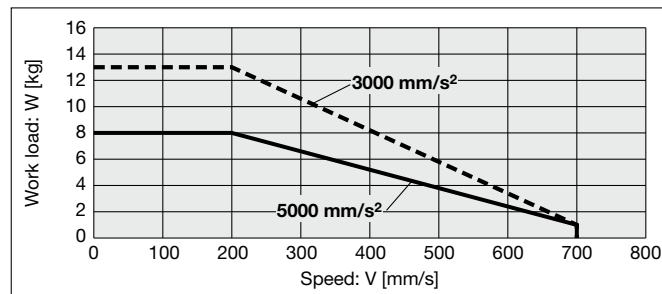

EQY32□HB

Horizontal/Lead 8

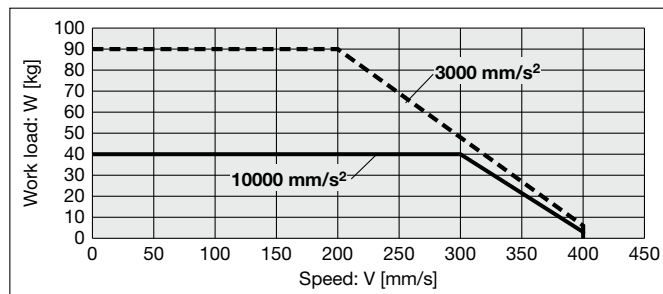

Vertical/Lead 8

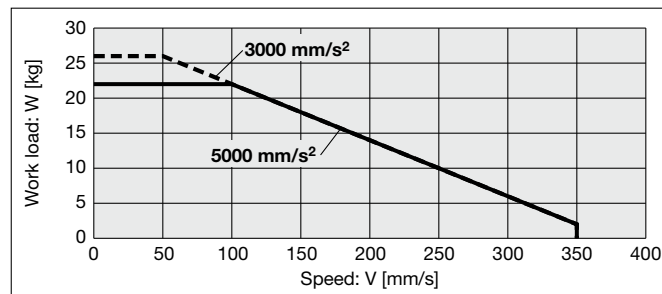

EQY32□HC

Horizontal/Lead 4

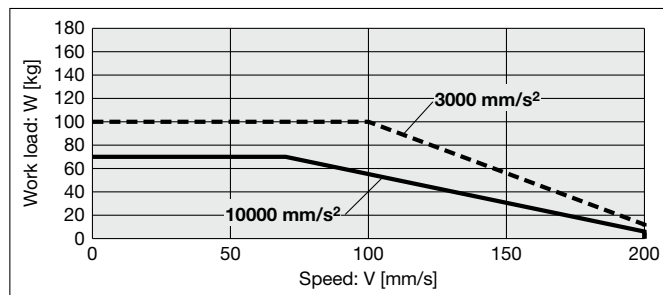

Vertical/Lead 4

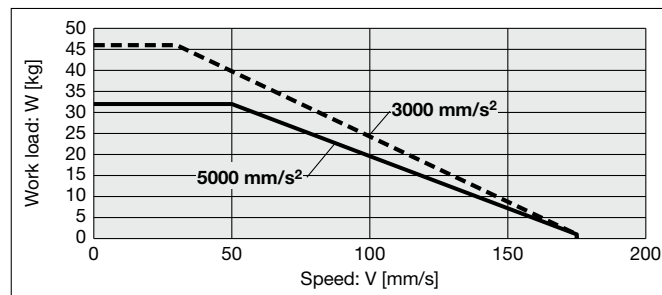

Graph of Allowable Lateral Load on the Rod End (Guide)

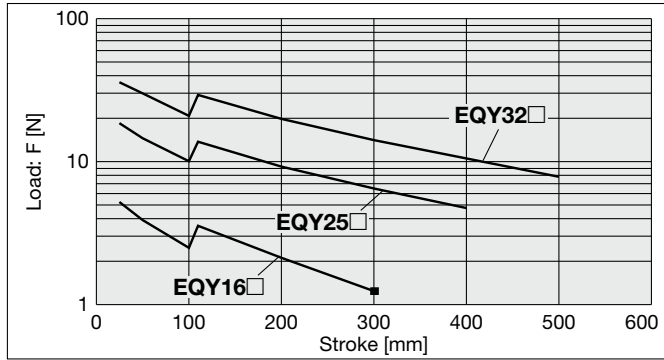

[Stroke] = [Product stroke] + [Distance from the rod end to the center of gravity of the workpiece]

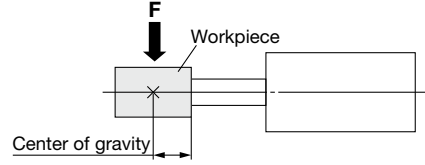

Rod Displacement: δ [mm]

Stroke Size	30	50	100	150	200	250	300	350	400	450	500
16	±0.4	±0.5	±0.9	±0.8	±1.1	±1.3	±1.5	—	—	—	—
25	±0.3	±0.4	±0.7	±0.7	±0.9	±1.1	±1.3	±1.5	±1.7	—	—
32	±0.3	±0.4	±0.7	±0.6	±0.8	±1.0	±1.1	±1.3	±1.5	±1.7	±1.8

* The values without a load are shown.

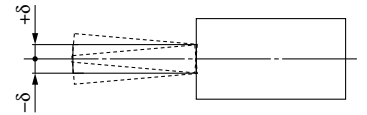

Non-rotating Accuracy of Rod

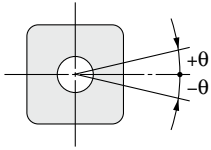

Size	Non-rotating accuracy θ
16	±1.1°
25	±0.8°
32	±0.7°

* Avoid using the electric actuator in such a way that rotational torque would be applied to the piston rod.

Failure to do so may result in the deformation of the non-rotating guide, abnormal auto switch responses, play in the internal guide, or an increase in the sliding resistance.

Force Conversion Graph (Guide)

EQY16□H

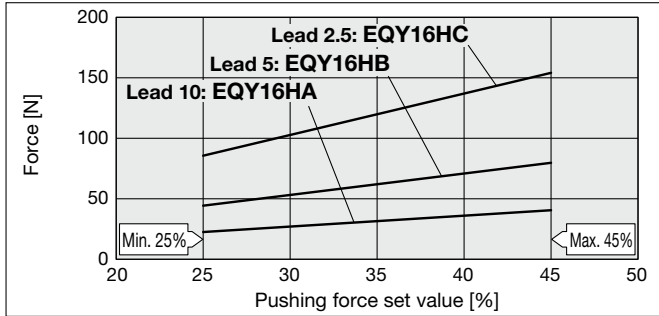

Ambient temperature	Pushing force set value [%]	Duty ratio [%]	Continuous pushing time [min]
40°C or less	45 or less	100	No restriction

EQY32□H

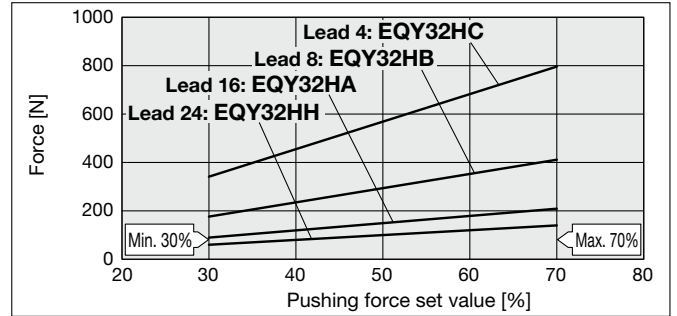

Ambient temperature	Pushing force set value [%]	Duty ratio [%]	Continuous pushing time [min]
40°C or less	70 or less	100	No restriction

EQY25□H

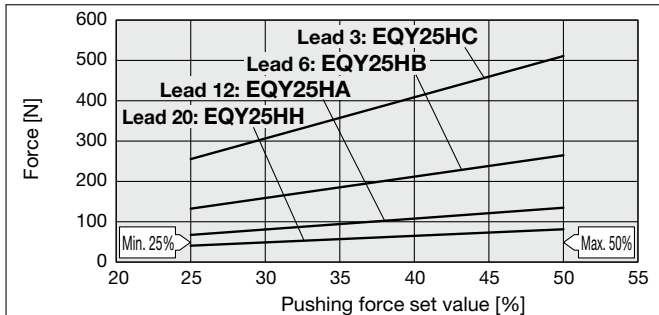

Ambient temperature	Pushing force set value [%]	Duty ratio [%]	Continuous pushing time [min]
40°C or less	50 or less	100	No restriction

<Set Values for Vertical Upward Transfer Pushing Operations>

For vertical loads (upward), set the pushing force to the max. value shown below and operate at the work load or less.

Model	EQY16			EQY25			EQY32					
Lead	A	B	C	H	A	B	C	H	A	B	C	
Work load [kg]	1	1.5	3	1	2.5	5	10	2	4.5	9	18	
Pushing force	45%			50%			70%					

e-Actuator Easy to Operate

Integrated Controller / Rod Type

EQY□H Series EQY16, 25, 32



* Excludes size 16



How to Order

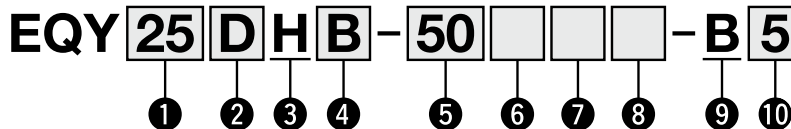

① Size

16
25
32

② Motor mounting position/Motor cover direction

Motor mounting position: In-line

Symbol	Motor cover direction*1	Size
D	—	25/32
D1	Left side	16
D2	Right side	
D3	Top side	
D4	Bottom side	

*1 This is the direction seen from the connector side.

Motor mounting position: Parallel

Symbol	Direction	Size
Nil	Top side	16/25/32
R	Right side	
L	Left side	

③ Motor type

H	Battery-less absolute (Step motor 24 VDC)
---	---

④ Lead [mm]

Symbol	EQY16	EQY25	EQY32
H	—	20	24
A	10	12	16
B	5	6	8
C	2.5	3	4

⑤ Stroke [mm]

30	30
to	to
500	500

* For details, refer to the applicable stroke table below.

⑥ Motor option

Nil	Without option
B	With lock

⑦ Rod end thread

Nil	Rod end female thread
M	Rod end male thread (1 rod end nut is included.)

⑨ Controller position

B	Integrated controller
---	-----------------------

⑩ Parallel input

5	NPN
6	PNP

EQY16 Motor cover direction

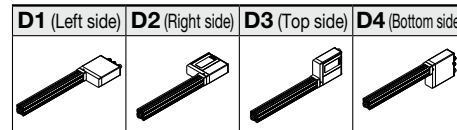

Motor mounting position: Parallel

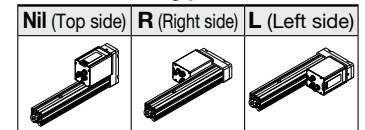

⑧ Mounting*2

Symbol	Type	Motor mounting position					
		Parallel			In-line		
		16	25	32	16	25	32
Nil	Ends tapped*3 Body bottom tapped	●	●	●	●	●	●
L	Foot bracket	●	●	●	—	—	—
F	Rod flange*3 *6	●	●	●	●	●	●
G	Head flange*5	●	●	—	—	—	—
D	Double clevis*4	●	●	●	—	—	—

*1 Motor mounting position: For the parallel mounting type, the motor units with the following sizes and strokes protrude from the body end. Check for interference with workpieces before selecting a model.

- EQY16 Without lock: 30 mm stroke, With lock: 30, 50 mm strokes
- EQY25 Without lock: 30 mm stroke, With lock: 30, 50 mm strokes
- EQY32 Without lock: 30 mm stroke, With lock: 30, 50 mm strokes

*2 The mounting bracket is shipped together with the product but does not come assembled.

*3 For the horizontal cantilever mounting of the rod flange or ends tapped types, use the actuator within the following stroke range.

- EQY25: 200 or less ·EQY32: 100 or less

*4 For the mounting of the double clevis type, use the actuator within the following stroke range.

- EQY16: 100 or less ·EQY25: 200 or less ·EQY32: 200 or less

*5 The head flange type is not available for the EQY32.

*6 For the parallel motor mounting position, the rod flange type is not available for the following sizes and strokes.

- EQY16 Without lock: 30 mm stroke, With lock: 30, 50, 100 mm strokes
- EQY25 Without lock: 30 mm stroke, With lock: 30, 50 mm strokes
- EQY32 Without lock: 30 mm stroke, With lock: 30, 50 mm strokes

Applicable Stroke Table

Size	Stroke [mm]											
	30	50	100	150	200	250	300	350	400	450	500	Manufacturable stroke range
16	●	●	●	●	●	●	●	—	—	—	—	10 to 300
25	●	●	●	●	●	●	●	●	●	—	—	15 to 400
32	●	●	●	●	●	●	●	●	●	●	●	20 to 500

The power cable and the parallel I/O cable need to be ordered separately. Refer to page 80 for details.

The auto switches should be ordered separately. For details, refer to pages 51 to 54.

Specifications

Model		EQY16□H			EQY25□H				EQY32□H					
Actuator specifications	Stroke [mm]	30 to 300			30 to 400				30 to 500					
	Work load [kg]*1	Horizontal	17	25	40	8	26	40	70	30	50	90	100	
		Vertical	3	6	10	2	8	16	30	3	13	26	46	
	Pushing force [N]*2 *3 *4		23 to 41	44 to 80	86 to 154	41 to 81	67 to 135	132 to 265	255 to 511	60 to 140	90 to 209	176 to 411	341 to 796	
	Speed [mm/s]	Stroke range	Up to 300	15 to 700	8 to 350	4 to 175	30 to 900	18 to 700	9 to 450	5 to 225	30 to 900	24 to 800	12 to 400	6 to 200
			350 to 400	—	—	—	30 to 900	18 to 600	9 to 300	5 to 150	30 to 900	24 to 640	12 to 320	6 to 160
			450 to 500	—	—	—	—	—	—	—	30 to 900	24 to 640	12 to 320	6 to 160
	Max. acceleration/ deceleration [mm/s ²]	Horizontal	10000*1											
		Vertical	5000*1											
	Pushing speed [mm/s]*5		25			35				30				
	Positioning repeatability [mm]		±0.02											
	Lost motion [mm]*6		0.1 or less											
	Lead [mm]		10	5	2.5	20	12	6	3	24	16	8	4	
Impact/Vibration resistance [m/s ²]*7		50/20												
Actuation type		Ball screw + Belt (EQY□H), Ball screw (EQY□DH)												
Guide type		Sliding bushing (Piston rod)												
Operating temperature range [°C]		5 to 40												
Operating humidity range [%RH]		90 or less (No condensation)												
Enclosure		IP40												
Electric specifications	Motor size	□28			□42				□56.4					
	Motor type	Battery-less absolute (Step motor 24 VDC)												
	Encoder	Battery-less absolute												
	Power supply voltage [V]	24 VDC ±10%												
Lock unit specifications	Power [W]*8 *9	Max. power 82			Max. power 86				Max. power 109					
	Type*10	Non-magnetizing lock												
	Holding force [N]	29	59	98	20	78	157	294	29	127	255	451		
	Power [W]*9	2.9			5				5					
Power supply voltage [V]		24 VDC ±10%												

- *1 Horizontal: Please use an external guide (friction coefficient: 0.1 or less). The work load shows the maximum value. The actual work load and transfer speed change according to the condition of the external guide.
 For the speed, acceleration, and duty ratio according to the work load, check the "Speed-Work Load Graph" in the catalog.
 Vertical: If the rod orientation is vertical or radial load is applied to the rod, please use an external guide (friction coefficient: 0.1 or less). The work load represents the maximum value. The actual work load and transfer speed change according to the condition of the external guide.
 For the speed, acceleration, and duty ratio according to the work load, check the "Speed-Work Load Graph" in the catalog.
 The values shown in () are the max. acceleration/deceleration.
 Set the acceleration/deceleration speed to 10000 [mm/s²] or less for the horizontal direction and 5000 [mm/s²] or less for the vertical direction.
- *2 Pushing force accuracy is ±20% (F.S.).
- *3 The pushing force set values for EQY16□H are 25% to 45%, for EQY25□H are 25% to 50%, and for EQY32□H are 30% to 70%.
 The pushing force values change according to the duty ratio and pushing speed. Check the "Force Conversion Graph" in the catalog.
- *4 The speed and force may change depending on the cable length, load, and mounting conditions. Furthermore, if the cable length exceeds 5 m, then it will decrease by up to 10% for each 5 m. (At 15 m: Reduced by up to 20%)
- *5 The allowable speed for pushing operation. When push conveying a workpiece, operate at the vertical work load or less.
- *6 A reference value for correcting errors in reciprocal operation
- *7 Impact resistance: No malfunction occurred when the actuator was tested with a drop tester in both an axial direction and a perpendicular direction to the lead screw. (The test was performed with the actuator in the initial state.)
 Vibration resistance: No malfunction occurred in a test ranging between 45 to 2000 Hz. The test was performed in both an axial direction and a perpendicular direction to the lead screw. (The test was performed with the actuator in the initial state.)
- *8 Indicates the max. power during operation (including the controller). This value can be used for the selection of the power supply.
- *9 For an actuator with lock, add the power for the lock.
- *10 With lock only

Model Selection

EQFS□H Series

EQY□H Series

EQYG□H Series

Auto Switch

Electric Specifications

Wiring Examples

Options

Weight

Top/Right/Left Side Parallel Motor

Series	EQY16						
Stroke [mm]	30	50	100	150	200	250	300
Product weight [kg]	0.85	0.88	1.01	1.17	1.34	1.45	1.56

Series	EQY25										EQY32									
Stroke [mm]	30	50	100	150	200	250	300	350	400	30	50	100	150	200	250	300	350	400	450	500
Product weight [kg]	1.74	1.81	1.98	2.24	2.42	2.59	2.77	2.94	3.12	2.74	2.85	3.14	3.42	3.82	4.11	4.39	4.68	4.97	5.25	5.54

In-line Motor

Series	EQY16D						
Stroke [mm]	30	50	100	150	200	250	300
Product weight [kg]	0.84	0.86	0.99	1.15	1.33	1.44	1.55

Series	EQY25D										EQY32D									
Stroke [mm]	30	50	100	150	200	250	300	350	400	30	50	100	150	200	250	300	350	400	450	500
Product weight [kg]	1.60	1.67	1.84	2.10	2.28	2.45	2.63	2.80	2.98	2.55	2.66	2.95	3.23	3.63	3.92	4.20	4.49	4.78	5.06	5.35

Additional Weight

[kg]

Size	16	25	32	
Lock/Motor cover	0.19	0.33	0.65	
Rod end male thread	Male thread	0.01	0.03	0.03
	Nut	0.01	0.02	0.02
Foot bracket (2 sets including mounting bolt)	0.06	0.08	0.14	
Rod flange (including mounting bolt)	0.13	0.17	0.20	
Head flange (including mounting bolt)				
Double clevis (including pin, retaining ring, and mounting bolt)	0.08	0.16	0.22	

Construction

Top/Right/Left side parallel motor

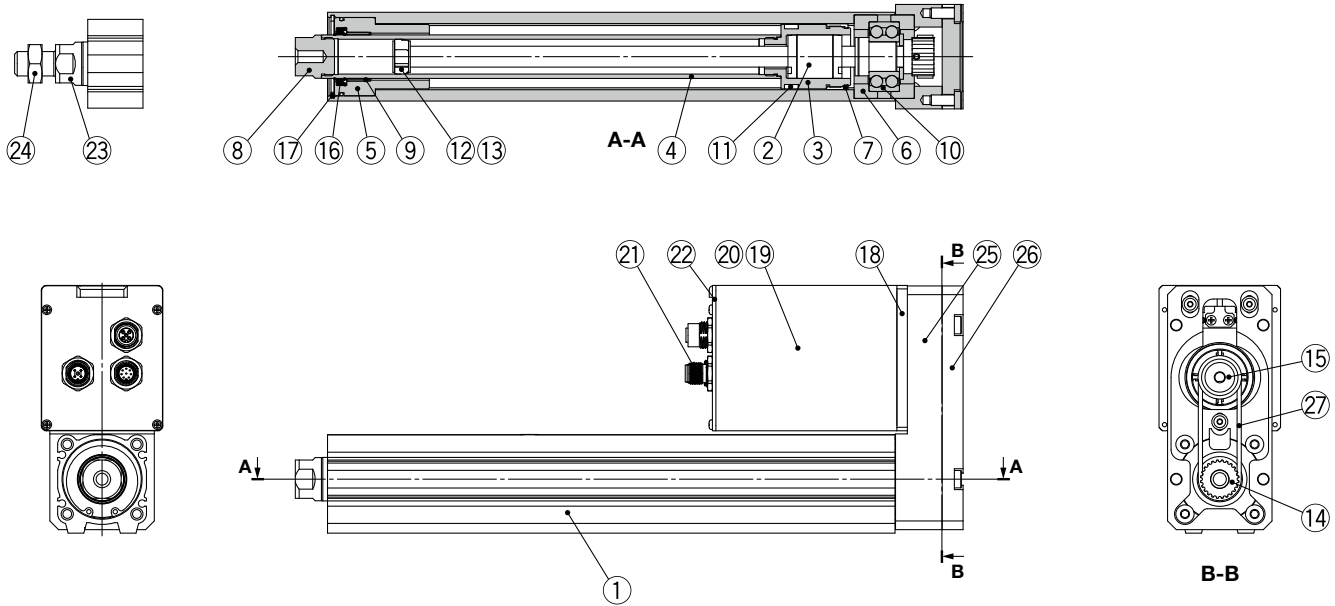

In-line motor

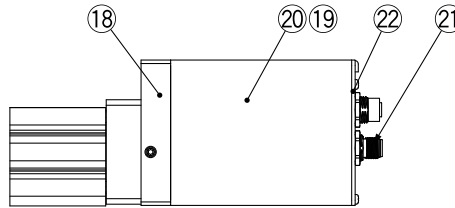

Component Parts

No.	Description	Material	Note
1	Body	Aluminum alloy	Anodized
2	Ball screw assembly	—	
3	Piston	Aluminum alloy	
4	Piston rod	Stainless steel	Hard chrome plating
5	Rod cover	Aluminum alloy	
6	Bearing holder	Aluminum alloy	
7	Rotation stopper	Synthetic resin	
8	Socket (Female thread)	Free cutting carbon steel	Nickel plating
9	Bushing	Bearing alloy	
10	Bearing	—	
11	Magnet	—	
12	Wear ring holder	Stainless steel	101 mm stroke or more
13	Wear ring	Synthetic resin	101 mm stroke or more
14	Screw pulley/hub	Aluminum alloy	
15	Motor pulley/hub	Aluminum alloy	
16	Seal	NBR	
17	Retaining ring	Steel for spring	
18	Motor adapter	Aluminum alloy	Anodized
19	Motor	—	
20	Motor cover	Aluminum alloy	Anodized
21	Connector	—	
22	End cover	Aluminum alloy	Anodized
23	Socket (Male thread)	Free cutting carbon steel	Nickel plating/ Rod end male thread
24	Hexagon nut	—	Rod end male thread

Component Parts (Top/Right/Left side parallel only)

No.	Description	Material	Note
25	Return box	Aluminum die-casted	Coating
26	Return plate	Aluminum die-casted	Coating
27	Belt	—	

Replacement Parts (Top/Right/Left side parallel only)/Belt

No.	Size	Order no.
27	16	LE-D-2-7
	25	LE-D-19-3
	32	LE-D-19-4

Replacement Parts/Grease Pack

Applied portion	Order no.
Piston rod	GR-S-010 (10 G) GR-S-020 (20 G)

Model Selection

EQFS□H Series

EQY□H Series

EQYG□H Series

Auto Switch

Electric Specifications

Wiring Examples

Options

Dimensions: Top Side Parallel Motor

EQY16H

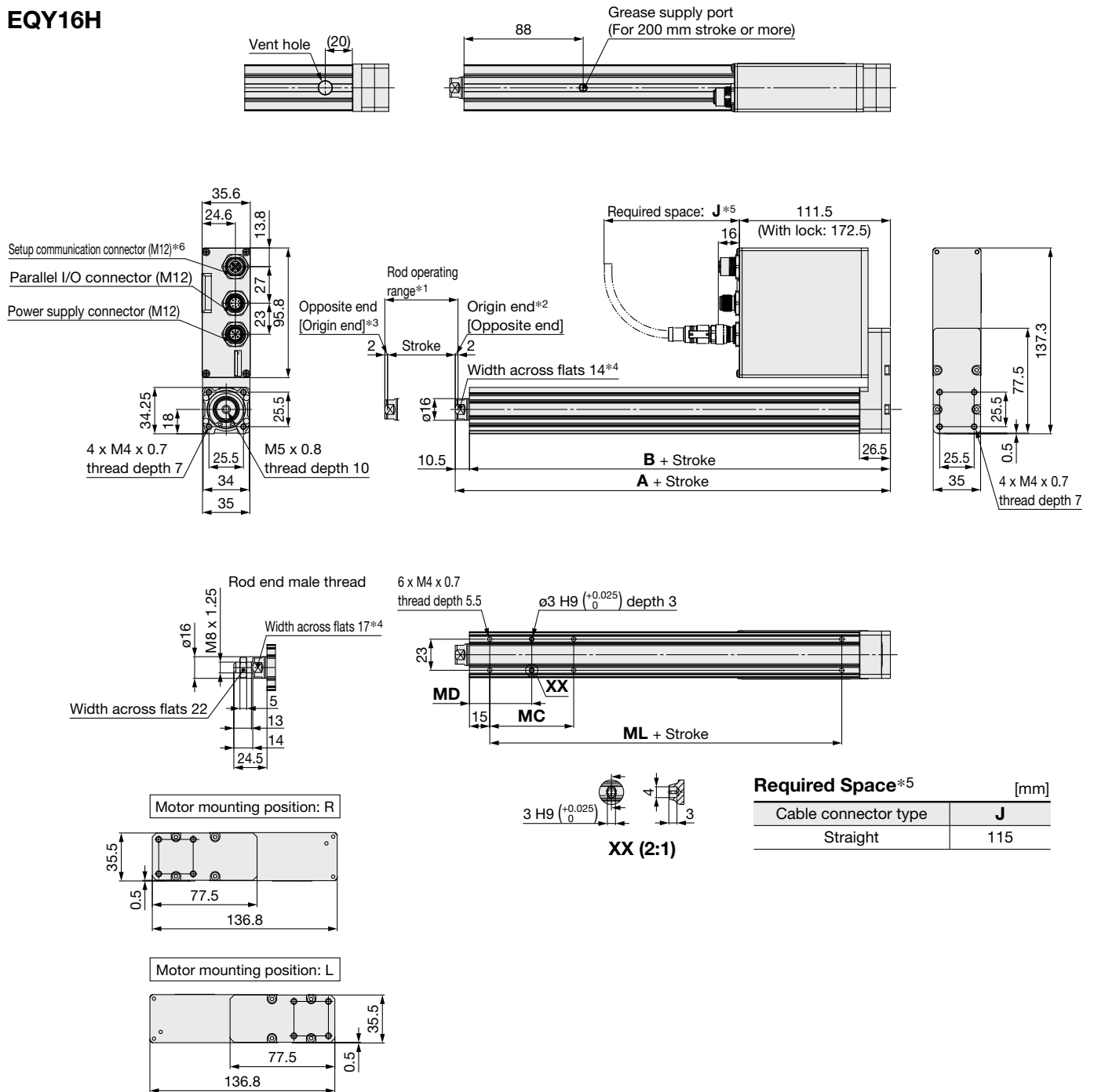

- *1 The range of movement of the rod according to the movement instructions. Make sure that workpieces mounted on the rod do not interfere with other workpieces or the facilities around the rod.
- *2 Indicates the factory default origin position (0 mm)
- *3 [] refers to when the rotation direction reference is changed.
- *4 The direction of the rod end width across flats is different for each single unit, so it is not always the same as the direction in the drawing.
- *5 The amount of space required to connect the various cables and mount the product
Provide this amount of space for cable handling. Order the cable separately.
- *6 A female dustproof cap comes with the setup communication connector (M12).

Dimensions						[mm]
Stroke [mm]	A	B	MC	MD	ML	
30	105	94.5	17	23.5	40	
50, 100			32	31		
150, 200, 250, 300	125	114.5	62	46	60	

Dimensions: Top Side Parallel Motor

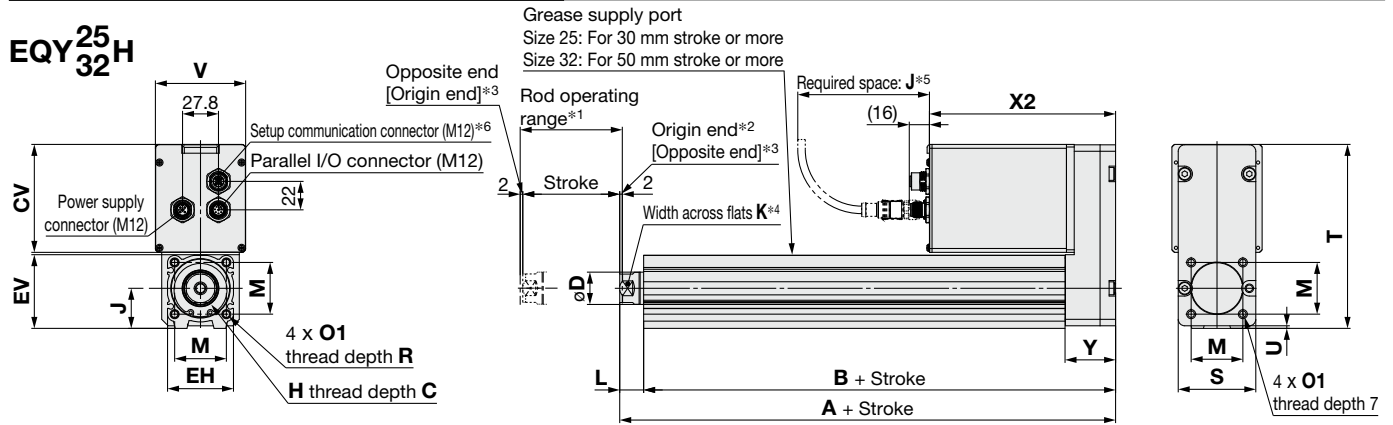

Motor option: With lock

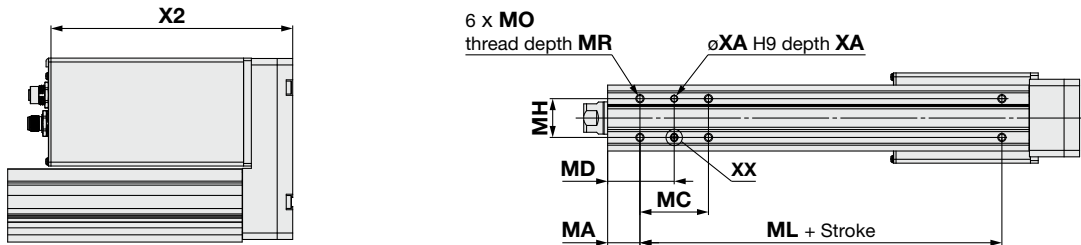

Motor mounting position

Left side parallel Right side parallel

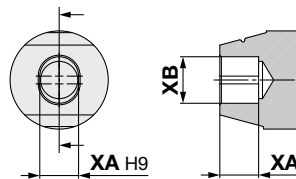
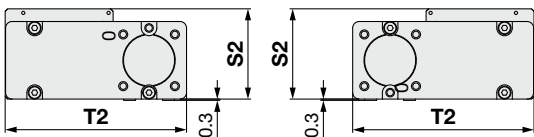

XX (2:1)

Required space*5 [mm]

Cable connector type	J
Straight	115

* The right angled type connector cannot be used.

- *1 The range of movement of the rod according to the movement instructions. Make sure that workpieces mounted on the rod do not interfere with other workpieces or the facilities around the rod.
- *2 Indicates the factory default origin position (0 mm)
- *3 [] refers to when the rotation direction reference is changed.
- *4 The direction of rod end width across flats differs depending on the products.
- *5 The amount of space required to connect the various cables and mount the product. Provide this amount of space for cable handling. Order the cable separately.
- *6 A female dustproof cap comes with the setup communication connector (M12).

Dimensions

Size	Stroke range [mm]	A	B	C	D	EH	EV	H	J	K	L	M	O1	R	S	S2	T	T2	U	CV	V	X2		Y
																						Without lock	With lock	
25	15 to 100	136.2	121.7	13	20	44	45.5	M8 x 1.25	24	17	14.5	34	M5 x 0.8	8	46	58.1	115	113.6	1	66.3	57.8	144	184	32.2
	101 to 400	161.2	146.7																					
32	20 to 100	153.6	135.1	13	25	51	56.5	M8 x 1.25	31	22	18.5	40	M6 x 1	10	60	70.8	142	140.3	2	83.5	69.8	144	189	39.1
	101 to 500	183.6	165.1																					

Body Bottom Tapped

Size	Stroke range [mm]	MA	MC	MD	MH	ML	MO	MR	XA	XB
25	15 to 39	20	24	32	29	50	M5 x 0.8	6.5	4	5
	40 to 100		42	41		75				
	101 to 124		59	49.5		75				
	125 to 200		76	58		75				
	201 to 400		76	58		75				
32	20 to 39	25	22	36	30	50	M6 x 1	8.5	5	6
	40 to 100		36	43		80				
	101 to 124		53	51.5		80				
	125 to 200		53	51.5		80				
	201 to 500		70	60		80				

Model Selection
 EQFS□H Series
 EQY□H Series
 EQYG□H Series
 Auto Switch
 Electric Specifications
 Wiring Examples
 Options

Dimensions: In-line Motor

EQY16DH

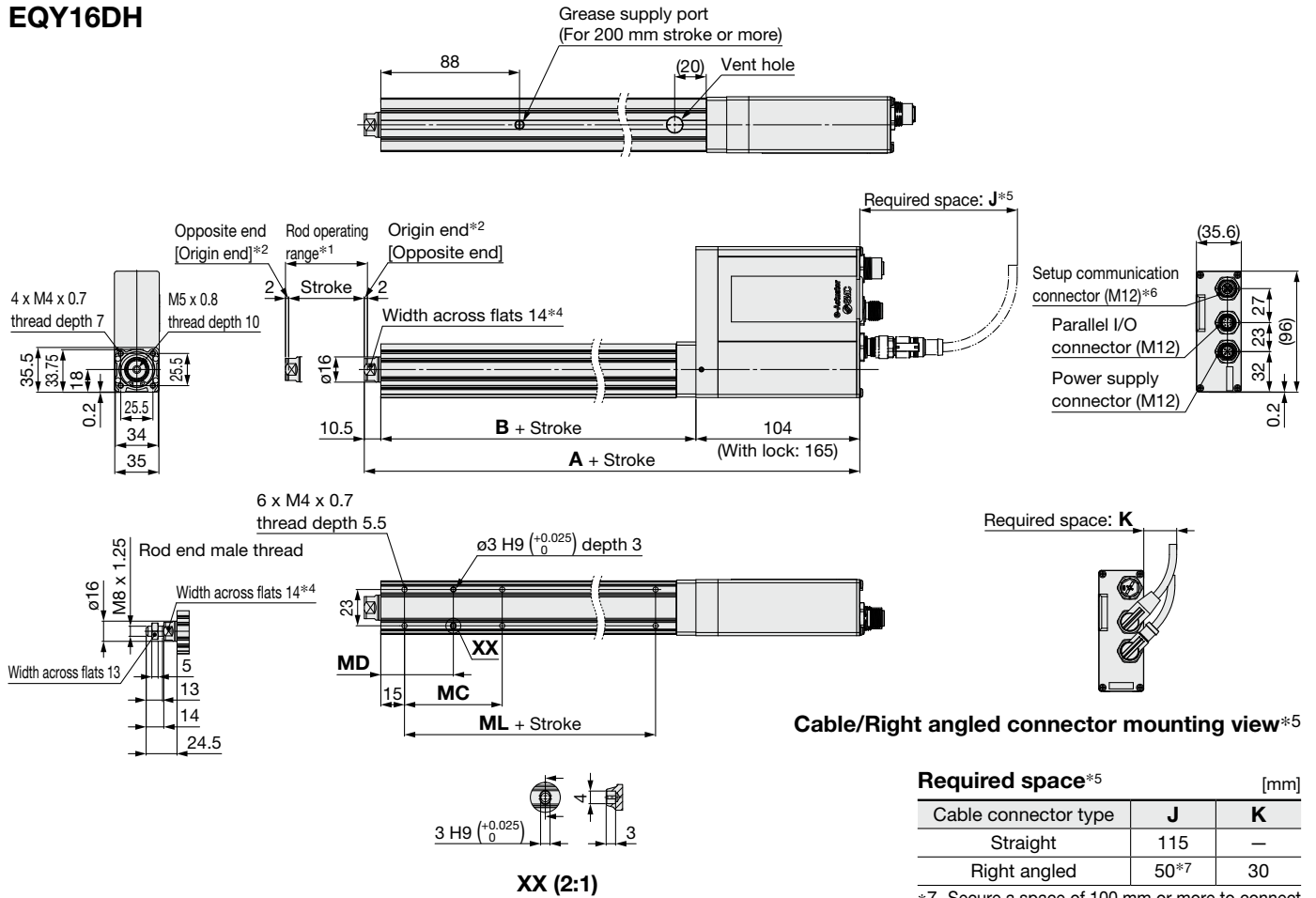

Motor mounting position: Motor cover direction (Right angled cable)

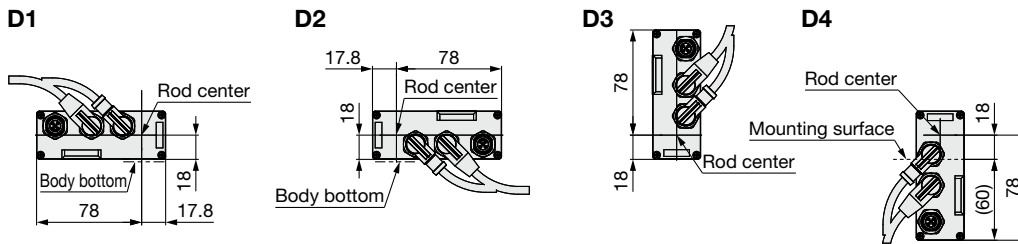

- *1 The range of movement of the rod according to the movement instructions. Make sure that workpieces mounted on the rod do not interfere with other workpieces or the facilities around the rod.
- *2 Indicates the factory default origin position (0 mm)
- *3 [] refers to when the rotation direction reference is changed.
- *4 The direction of the rod end width across flats is different for each single unit, so it is not always the same as the direction in the drawing.
- *5 The amount of space required to connect the various cables and mount the product
Provide this amount of space for cable handling. Order the cable separately.
- *6 A female dustproof cap comes with the setup communication connector (M12).

Dimensions

Stroke [mm]	A		B	MC	MD	ML
	Without lock	With lock				
30	190	251	76.5	17	23.5	40
50, 100				32	31	
150, 200, 250, 300	215	276	100.6	62	46	60

Dimensions: In-line Motor

EQY²⁵₃₂DH

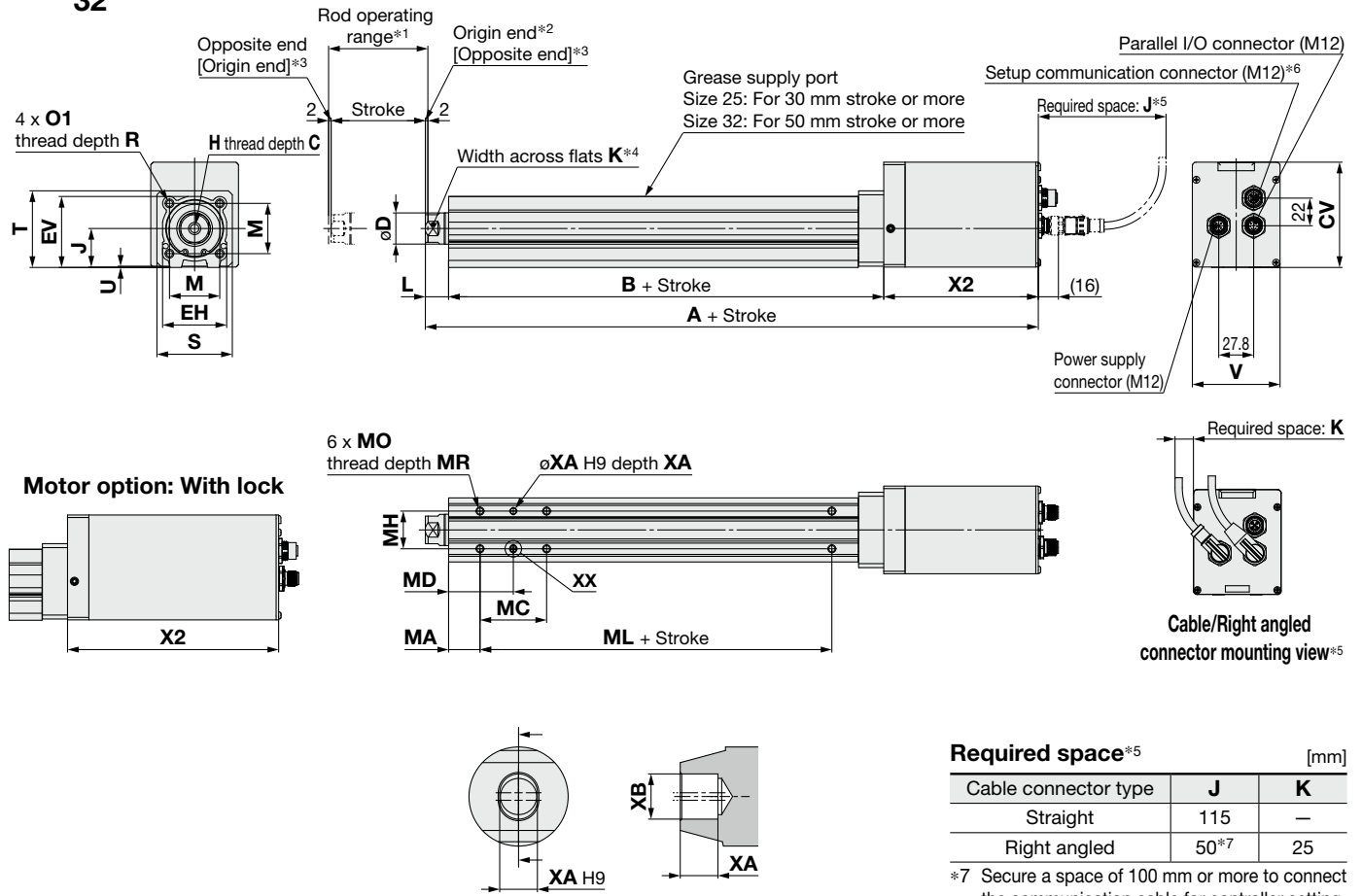

- *1 The range of movement of the rod according to the movement instructions. Make sure that workpieces mounted on the rod do not interfere with other workpieces or the facilities around the rod.
- *2 Indicates the factory default origin position (0 mm)
- *3 [] refers to when the rotation direction reference is changed.
- *4 The direction of rod end width across flats differs depending on the products.
- *5 The amount of space required to connect the various cables and mount the product. Provide this amount of space for cable handling. Order the cable separately.
- *6 A female dustproof cap comes with the setup communication connector (M12).

Dimensions

Size	Stroke range [mm]	A		B	C	D	EH	EV	H	J	K	L	M	O1	R	S	T	U	V	X2		CV
		Without lock	With lock																	Without lock	With lock	
25	15 to 100	243.4	283.4	102.9	13	20	44	45.5	M8 x 1.25	24	17	14.5	34	M5 x 0.8	8	45	46.5	1.5	57.8	126	166	66.6
	101 to 400	268.4	308.4	127.9																		
32	20 to 100	257.8	302.8	116.3	13	25	51	56.5	M8 x 1.25	31	22	18.5	40	M6 x 1	10	60	61	1	69.8	123	168	83.8
	101 to 500	287.8	332.8	146.3																		

Body Bottom Tapped

Size	Stroke range [mm]	MA	MC	MD	MH	ML	MO	MR	XA	XB
25	15 to 39	20	24	32	29	50	M5 x 0.8	6.5	4	5
	40 to 100		42	41		75				
	101 to 124		59	49.5						
	125 to 200		76	58						
	201 to 400		76	58						
32	20 to 39	25	22	36	30	50	M6 x 1	8.5	5	6
	40 to 100		36	43		80				
	101 to 124		53	51.5						
	125 to 200		53	51.5						
	201 to 500		70	60						

Model Selection
 EQFS□H Series
 EQY□H Series
 EQYG□H Series
 Auto Switch
 Electric Specifications
 Wiring Examples
 Options

Dimensions

End male thread: EQY ¹⁶25□H ^HA ^B□ ^C□M

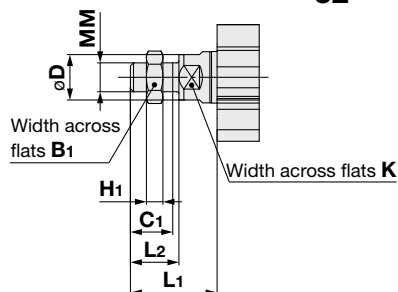

End Male Thread [mm]

Size	B1	C1	øD	H1	K	L1	L2	MM
16	13	12	16	5	14	24.5	14	M8 x 1.25
25	22	20.5	20	8	17	38	23.5	M14 x 1.5
32	22	20.5	25	8	22	42	23.5	M14 x 1.5

* The L1 measurement is when the unit is in the original position. At this position, 2 mm at the end.

* Refer to the **Web Catalog** for details on the rod end nut and mounting bracket.
 * Refer to the specific product precautions (“Handling”) in the **Web Catalog** when mounting end brackets such as knuckle joint or workpieces.

Foot bracket: EQY ¹⁶25H ^HA ^B□ ^C□L

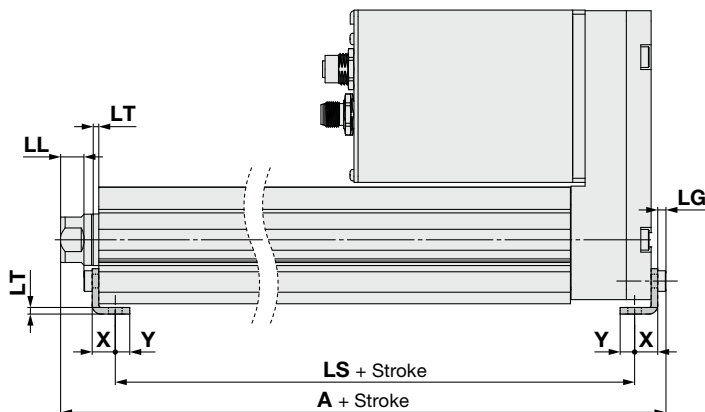
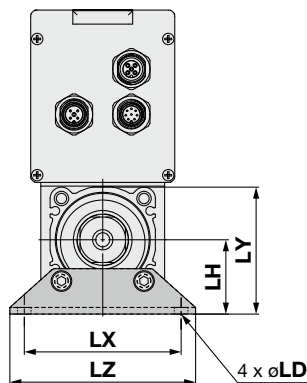

Outward mounting

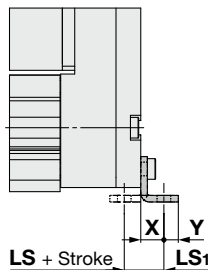

Included parts
 · Foot bracket
 · Body mounting bolt

Foot Bracket [mm]

Size	Stroke range [mm]	A	LS	LS ₁	LL	LD	LG	LH	LT	LX	LY	LZ	X	Y
16	30 to 100	106.5	77.1	16.1	5.4	6.6	2.8	24	2.3	48	40.3	62	9.2	5.8
	101 to 300	126.5	97.1											
25	30 to 100	142.3	104.5	19.8	8.4	6.6	3.5	30	2.6	57	51.5	71	11.2	5.8
	101 to 400	167.3	129.5											
32	30 to 100	160.8	119.1	19.2	11.3	6.6	4	36	3.2	76	61.5	90	11.2	7
	101 to 500	190.8	149.1											

Material: Carbon steel (Chromating)

* The A measurement is when the unit is in the original position. At this position, 2 mm at the end.

* When the motor mounting is the right or left side parallel type, the head side foot bracket should be mounted outward.

Dimensions

Rod flange: EQY $\begin{matrix} 16 \\ 25 \\ 32 \end{matrix}$ □ $\begin{matrix} H \\ A \\ B \\ C \end{matrix}$ - □ □ □ F

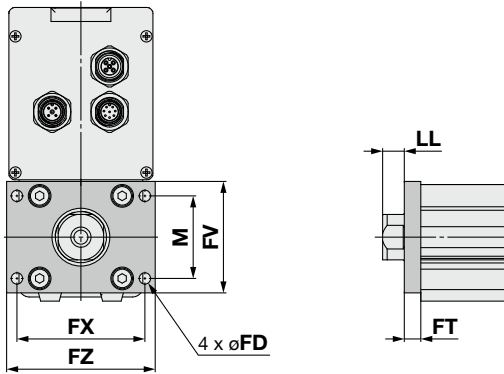

Head flange: EQY $\begin{matrix} 16 \\ 25 \\ 32 \end{matrix}$ H $\begin{matrix} A \\ B \\ C \end{matrix}$ - □ □ □ G

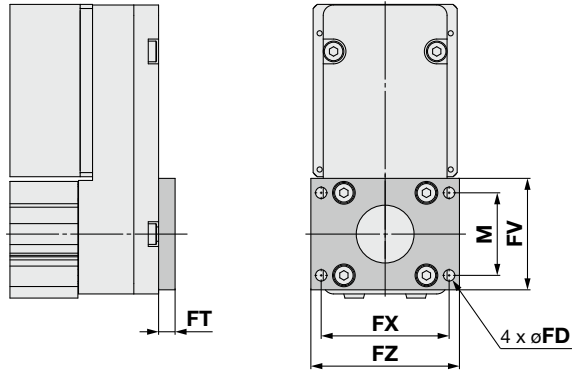

* The head flange type is not available for the EQY32.

Included parts
 · Flange
 · Body mounting bolt

Rod/Head Flange [mm]

Size	FD	FT	FV	FX	FZ	LL	M
16	6.6	8	39	48	60	2.5	—
25	5.5	8	48	56	65	6.5	34
32	5.5	8	54	62	72	10.5	40

Material: Carbon steel (Nickel plating)

Double clevis: EQY $\begin{matrix} 16 \\ 25 \\ 32 \end{matrix}$ H $\begin{matrix} A \\ B \\ C \end{matrix}$ - □ □ □ D

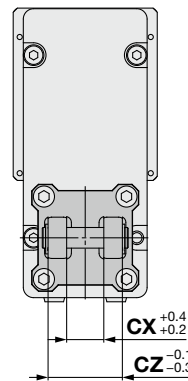
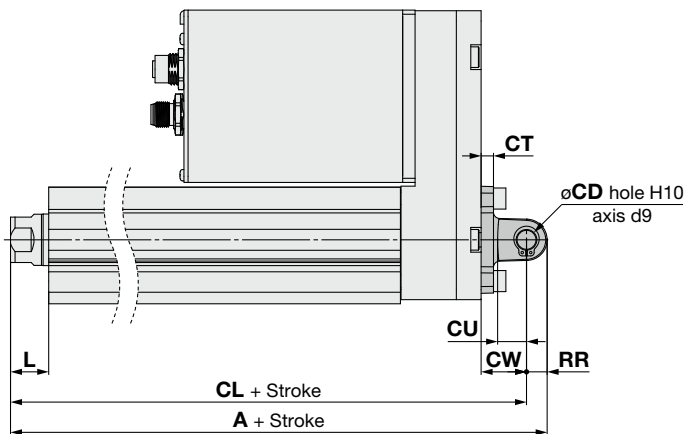

Included parts
 · Double clevis
 · Body mounting bolt
 · Clevis pin
 · Retaining ring

For the models and dimensions of the mounting bracket and simple joint bracket, refer to the **Web Catalog** for the LEY series.

* Refer to the **Web Catalog** for details on the rod end nut and mounting bracket.

Double Clevis [mm]

Size	Stroke range [mm]	A	CL	CB	CD	CT	CU	CW	CX	CZ	L	RR
16	30 to 100	128.4	119.4	20	8	5	12	18	8	16	10.5	9
	101 to 200	166.2	156.2	—	10	5	14	20	18	36	14.5	10
25	30 to 100	185.6	175.6	—	10	6	14	22	18	36	18.5	10
	101 to 200	215.6	205.6	—	10	6	14	22	18	36	18.5	10

Material: Cast iron (Coating)

* The A and CL measurements are when the unit is in the original position. At this position, 2 mm at the end.

Rod Type/EQY□H Series Auto Switch Mounting

Auto Switch Proper Mounting Position

Applicable auto switch: D-M9□(V), D-M9□E(V), D-M9□W(V), D-M9□A(V)

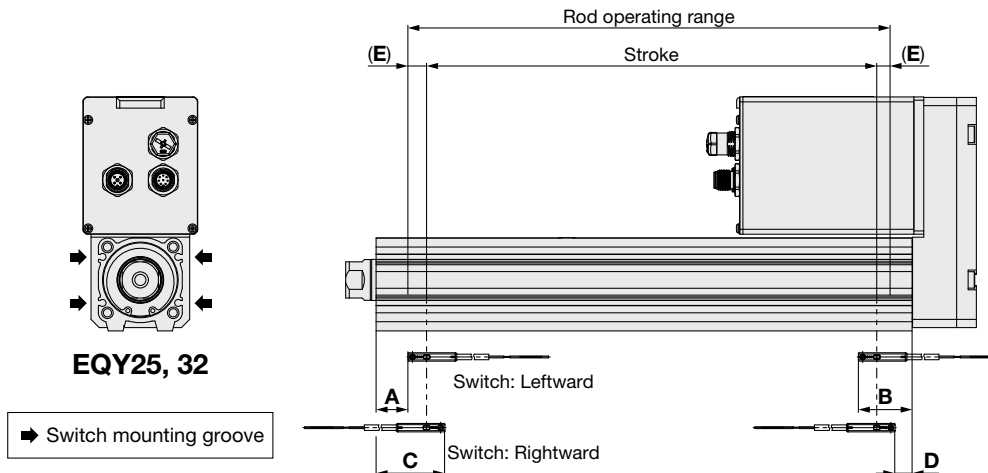

Size	Stroke range	Auto switch position				Return to origin distance	Operating range
		Leftward mounting		Rightward mounting			
		A	B	C	D		
16	30 to 100	21.5	46.5	33.5	34.5	(2)	2.9
	105 to 300	41.5		53.5			
25	30 to 100	27	62.5	39	50.5	(2)	4.2
	105 to 400	52		64			
32	30 to 100	30.5	65.5	42.5	53.5	(2)	4.9
	105 to 500	60.5		72.5			

- * The values in the table above are to be used as a reference when mounting auto switches for stroke end detection. Adjust the auto switch after confirming the operating conditions in the actual setting.
- * An auto switch cannot be mounted on the same side as a motor.
- * Since the operating range is provided as a guideline including hysteresis, it cannot be guaranteed (assuming approx. $\pm 30\%$ dispersion). It may change substantially depending on the ambient environment.
- * For the guide rod type (EQY□H), auto switches cannot be mounted behind the guide attachment (in the bottom groove on the side of the rod that sticks out).

Auto Switch Mounting

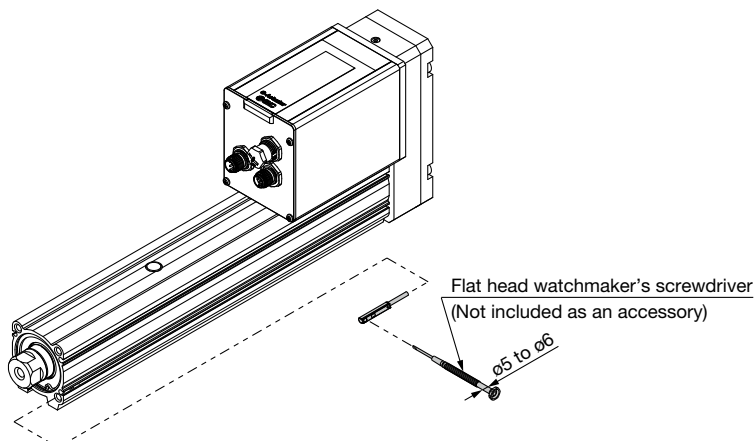

Tightening Torque for Auto Switch Mounting Screw [N·m]

Auto switch model	Tightening torque
D-M9□(V) D-M9□E(V) D-M9□W(V)	0.05 to 0.15
D-M9□A(V)	0.05 to 0.10

- * When tightening the auto switch mounting screw (included with the auto switch), use a watchmaker's screwdriver with a handle diameter of 5 to 6 mm.

Solid State Auto Switch Direct Mounting Type D-M9N(V)/D-M9P(V)/D-M9B(V)



Refer to the SMC website for details on products that are compliant with international standards.

Auto Switch Specifications

PLC: Programmable Logic Controller

D-M9□, D-M9□V (With indicator light)						
Auto switch model	D-M9N	D-M9NV	D-M9P	D-M9PV	D-M9B	D-M9BV
Electrical entry direction	In-line	Perpendicular	In-line	Perpendicular	In-line	Perpendicular
Wiring type	3-wire				2-wire	
Output type	NPN		PNP		—	
Applicable load	IC circuit, Relay, PLC				24 VDC relay, PLC	
Power supply voltage	5, 12, 24 VDC (4.5 to 28 V)				—	
Current consumption	10 mA or less				—	
Load voltage	28 VDC or less		—		24 VDC (10 to 28 VDC)	
Load current	40 mA or less				2.5 to 40 mA	
Internal voltage drop	0.8 V or less at 10 mA (2 V or less at 40 mA)				4 V or less	
Leakage current	100 μA or less at 24 VDC				0.8 mA or less	
Indicator light	Red LED illuminates when turned ON.					
Standard	CE/UKCA marking					

Grommet

- 2-wire load current is reduced (2.5 to 40 mA).
- Using flexible cable as standard spec.



Caution

Precautions

Fix the auto switch with the existing screw installed on the auto switch body. The auto switch may be damaged if a screw other than the one supplied is used.

Oilproof Flexible Heavy-duty Lead Wire Specifications

Auto switch model		D-M9N(V)	D-M9P(V)	D-M9B(V)
Sheath	Outside diameter [mm]	ø2.6		
Insulator	Number of cores	3 cores (Brown/Blue/Black)		2 cores (Brown/Blue)
	Outside diameter [mm]	ø0.88		
Conductor	Effective area [mm ²]	0.15		
	Strand diameter [mm]	ø0.05		
Min. bending radius [mm] (Reference values)		17		

- * Refer to the **Web Catalog** for solid state auto switch common specifications.
- * Refer to the **Web Catalog** for lead wire lengths.

Weight

[g]

Auto switch model		D-M9N(V)	D-M9P(V)	D-M9B(V)
Lead wire length	0.5 m (Nil)	8	7	7
	1 m (M)	14	13	13
	3 m (L)	41	38	38
	5 m (Z)	68	63	63

Dimensions

[mm]

D-M9□

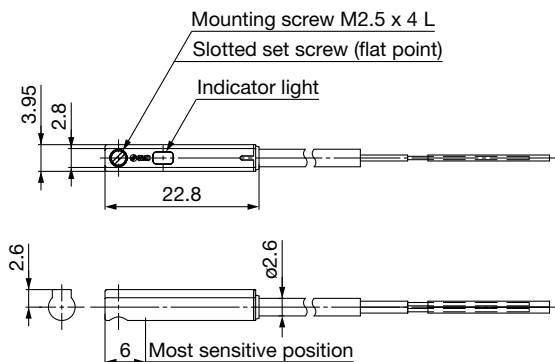

D-M9□V

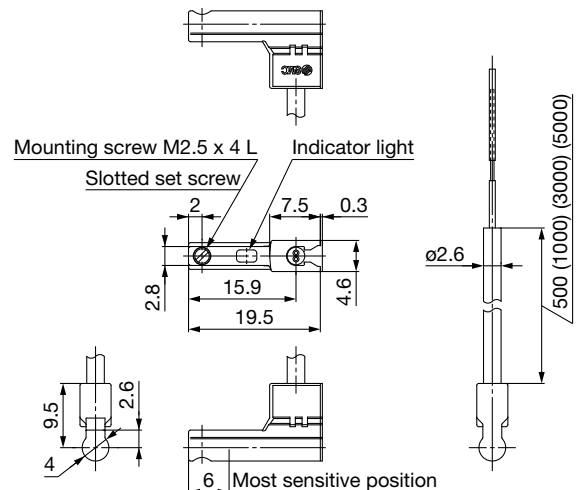

Normally Closed Solid State Auto Switch Direct Mounting Type D-M9NE(V)/D-M9PE(V)/D-M9BE(V)

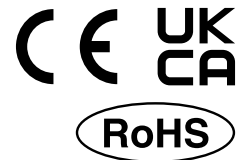

Refer to the SMC website for details on products that are compliant with international standards.

Auto Switch Specifications

PLC: Programmable Logic Controller

D-M9□E, D-M9□EV (With indicator light)						
Auto switch model	D-M9NE	D-M9NEV	D-M9PE	D-M9PEV	D-M9BE	D-M9BEV
Electrical entry direction	In-line	Perpendicular	In-line	Perpendicular	In-line	Perpendicular
Wiring type	3-wire				2-wire	
Output type	NPN		PNP		—	
Applicable load	IC circuit, Relay, PLC				24 VDC relay, PLC	
Power supply voltage	5, 12, 24 VDC (4.5 to 28 V)				—	
Current consumption	10 mA or less				—	
Load voltage	28 VDC or less		—		24 VDC (10 to 28 VDC)	
Load current	40 mA or less				2.5 to 40 mA	
Internal voltage drop	0.8 V or less at 10 mA (2 V or less at 40 mA)				4 V or less	
Leakage current	100 μA or less at 24 VDC				0.8 mA or less	
Indicator light	Red LED illuminates when turned ON.					
Standard	CE/UKCA marking					

Grommet

- Output signal turns on when no magnetic force is detected.
- Can be used for the actuator adopted by the solid state auto switch D-M9 series (excluding special order products)

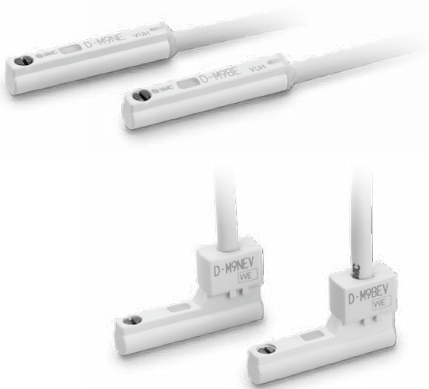

Oilproof Flexible Heavy-duty Lead Wire Specifications

Auto switch model		D-M9NE(V)	D-M9PE(V)	D-M9BE(V)
Sheath	Outside diameter [mm]	ø2.6		
Insulator	Number of cores	3 cores (Brown/Blue/Black)		2 cores (Brown/Blue)
	Outside diameter [mm]	ø0.88		
Conductor	Effective area [mm ²]	0.15		
	Strand diameter [mm]	ø0.05		
Min. bending radius [mm] (Reference values)		17		

- * Refer to the **Web Catalog** for solid state auto switch common specifications.
- * Refer to the **Web Catalog** for lead wire lengths.

Caution

Precautions

Fix the auto switch with the existing screw installed on the auto switch body. The auto switch may be damaged if a screw other than the one supplied is used.

Weight

[g]

Auto switch model		D-M9NE(V)	D-M9PE(V)	D-M9BE(V)
Lead wire length	0.5 m (Nil)	8	7	7
	1 m (M)*1	14	13	13
	3 m (L)	41	38	38
	5 m (Z)*1	68	63	63

*1 The 1 m and 5 m options are produced upon receipt of order.

Dimensions

[mm]

D-M9□E

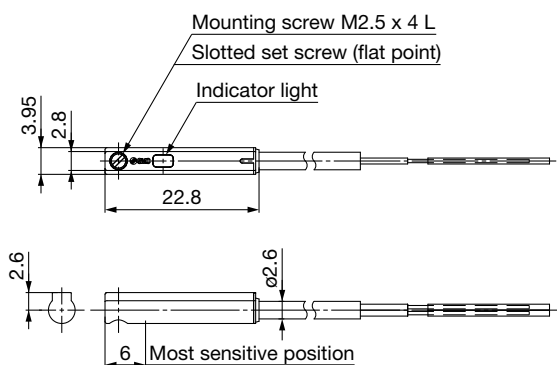

D-M9□EV

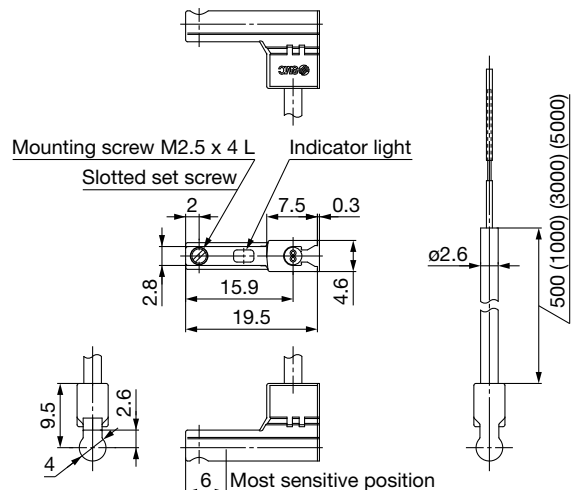

2-Color Indicator Solid State Auto Switch Direct Mounting Type D-M9NW(V)/D-M9PW(V)/D-M9BW(V)

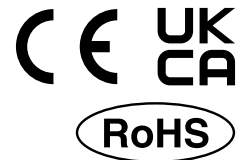

Refer to the SMC website for details on products that are compliant with international standards.

Auto Switch Specifications

PLC: Programmable Logic Controller

D-M9□W, D-M9□WV (With indicator light)						
Auto switch model	D-M9NW	D-M9NWV	D-M9PW	D-M9PWV	D-M9BW	D-M9BWV
Electrical entry direction	In-line	Perpendicular	In-line	Perpendicular	In-line	Perpendicular
Wiring type	3-wire				2-wire	
Output type	NPN		PNP		—	
Applicable load	IC circuit, Relay, PLC				24 VDC relay, PLC	
Power supply voltage	5, 12, 24 VDC (4.5 to 28 V)				—	
Current consumption	10 mA or less				—	
Load voltage	28 VDC or less		—		24 VDC (10 to 28 VDC)	
Load current	40 mA or less				2.5 to 40 mA	
Internal voltage drop	0.8 V or less at 10 mA (2 V or less at 40 mA)				4 V or less	
Leakage current	100 μA or less at 24 VDC				0.8 mA or less	
Indicator light	Operating range Red LED illuminates. Proper operating range Green LED illuminates.					
Standard	CE/UKCA marking					

Grommet

- 2-wire load current is reduced (2.5 to 40 mA).
- Using flexible cable as standard spec.
- The proper operating range can be determined by the color of the light. (Red → Green ← Red)



Caution

Precautions

Fix the auto switch with the existing screw installed on the auto switch body. The auto switch may be damaged if a screw other than the one supplied is used.

Oilproof Flexible Heavy-duty Lead Wire Specifications

Auto switch model		D-M9NW(V)	D-M9PW(V)	D-M9BW(V)
Sheath	Outside diameter [mm]	ø2.6		
Insulator	Number of cores	3 cores (Brown/Blue/Black)		2 cores (Brown/Blue)
	Outside diameter [mm]	ø0.88		
Conductor	Effective area [mm ²]	0.15		
	Strand diameter [mm]	ø0.05		
Min. bending radius [mm] (Reference values)		17		

- * Refer to the **Web Catalog** for solid state auto switch common specifications.
- * Refer to the **Web Catalog** for lead wire lengths.

Weight

[g]

Auto switch model		D-M9NW(V)	D-M9PW(V)	D-M9BW(V)
Lead wire length	0.5 m (Nil)	8	7	7
	1 m (M)	14	13	13
	3 m (L)	41	38	38
	5 m (Z)	68	63	63

Dimensions

[mm]

D-M9□W

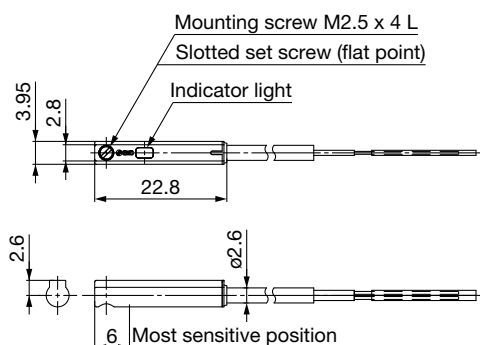

D-M9□WV

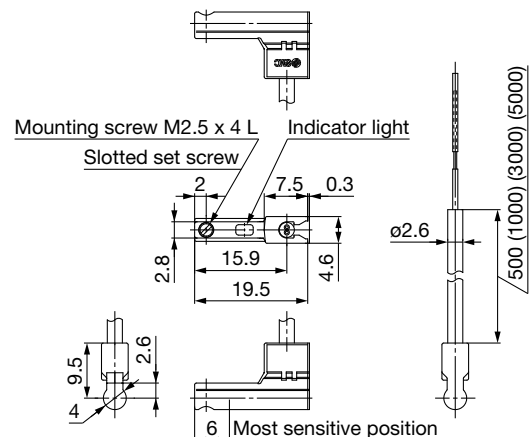

e-Actuator

Easy to Operate

Integrated Controller / Guide Rod Type

EQYG□H Series

p. 57

Battery-less Absolute (Step Motor 24 VDC)

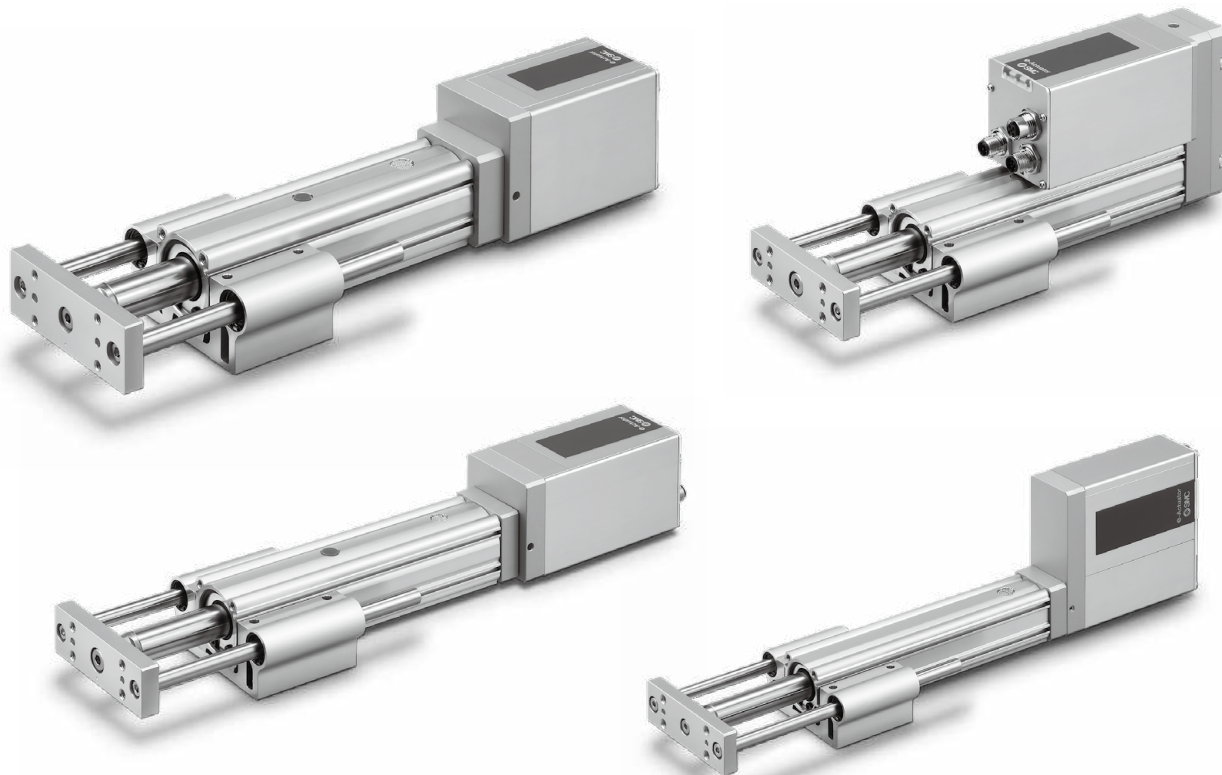

Model Selection

EQFS□H Series

EQY□H Series

EQYG□H Series

Auto Switch

Electric Specifications

Wiring Examples

Options

Model Selection

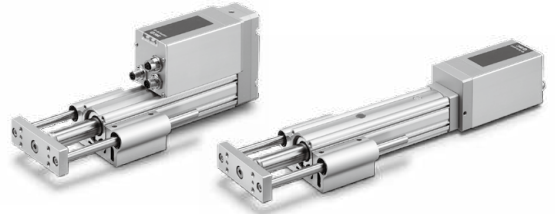

Moment Load Graph

Selection conditions

Mounting position		Vertical		Horizontal	
Max. speed [mm/s]		"Speed-Work Load Graph"		200 or less	Over 200
Bearing	Sliding bearing	Graphs ①, ②		Graphs ⑤, ⑥*1	Graphs ⑦, ⑧*1
	Ball bushing bearing	Graphs ③, ④		Graphs ⑨, ⑩	Graphs ⑪, ⑫

*1 For the sliding bearing type, the speed is restricted with a horizontal/moment load.

* The limit of vertical load mass varies depending on the lead and transfer speed. Check the "Speed-Work Load Graph."

Vertical Mounting, Sliding Bearing

① 70 mm stroke or less

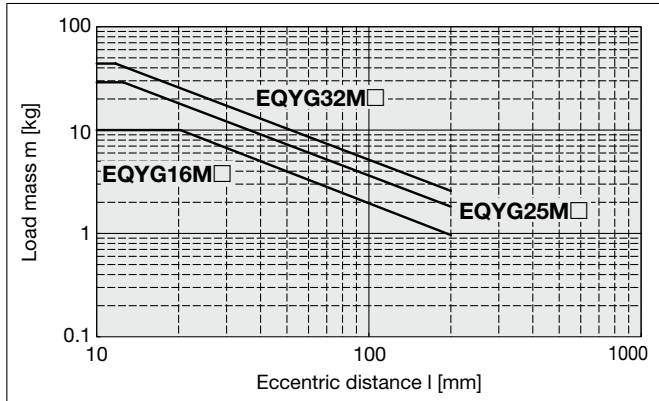

* The limit of vertical load mass varies depending on "lead" and "speed."
Check the "Speed-Work Load Graph" on pages 59 to 64.

② Over 75 mm stroke

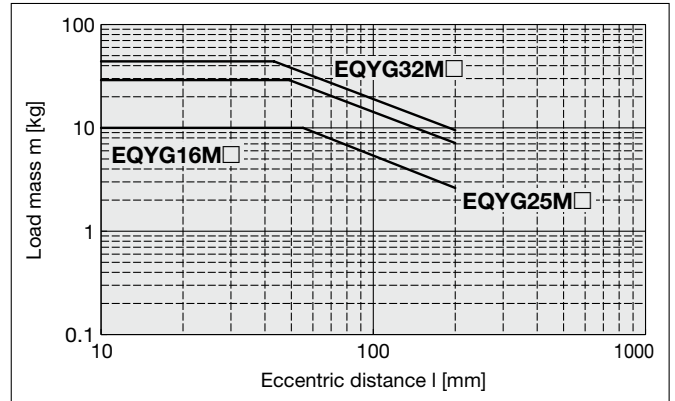

Vertical Mounting, Ball Bushing Bearing

③ 35 mm stroke or less

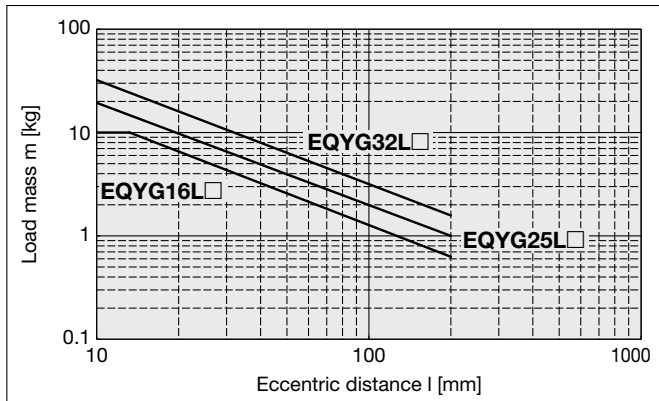

* The limit of vertical load mass varies depending on "lead" and "speed."
Check the "Speed-Work Load Graph" on pages 59 to 64.

④ Over 40 mm stroke

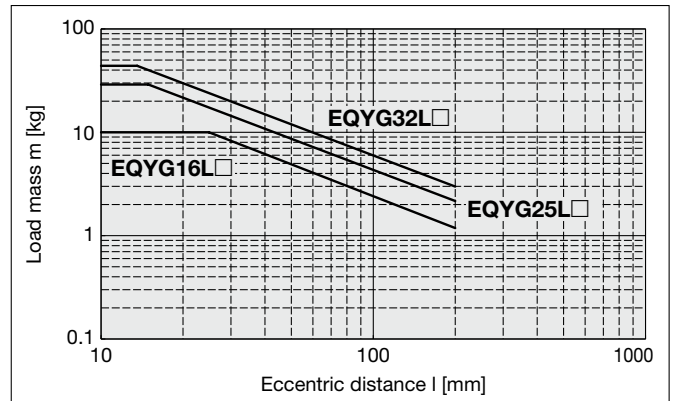

Moment Load Graph

Horizontal Mounting, Sliding Bearing

⑤ L = 50 mm Max. speed = 200 mm/s or less

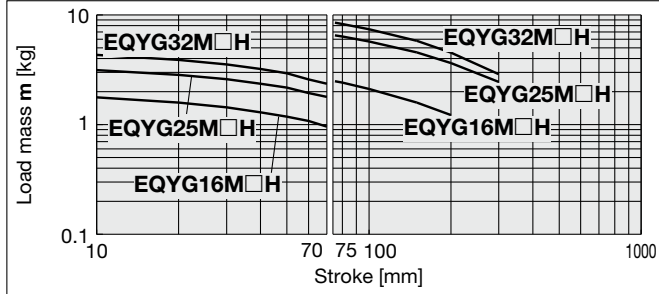

⑥ L = 100 mm Max. speed = 200 mm/s or less

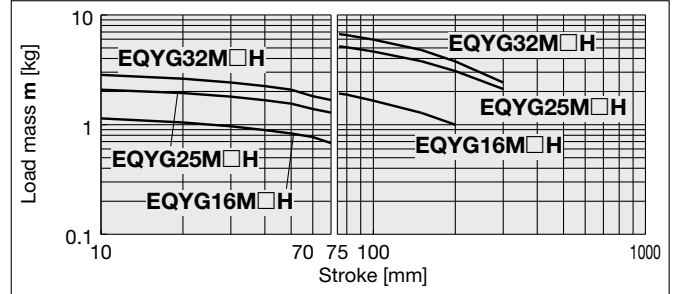

⑦ L = 50 mm Max. speed = Over 200 mm/s

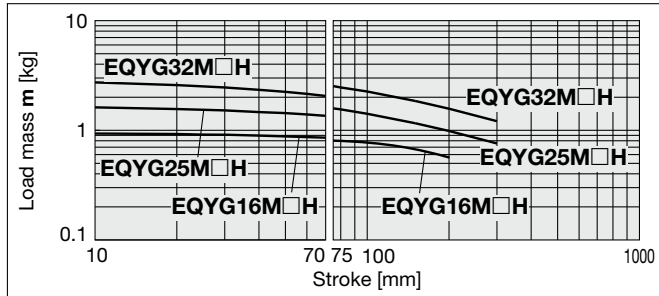

⑧ L = 100 mm Max. speed = Over 200 mm/s

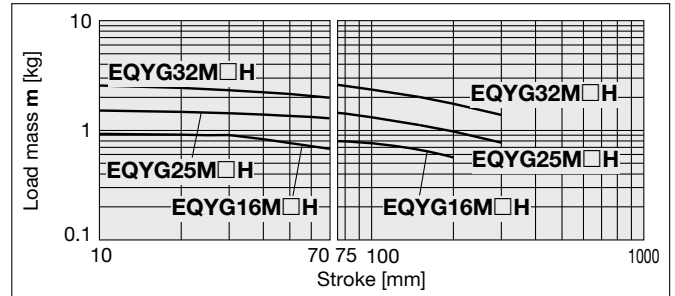

Horizontal Mounting, Ball Bushing Bearing

⑨ L = 50 mm Max. speed = 200 mm/s or less

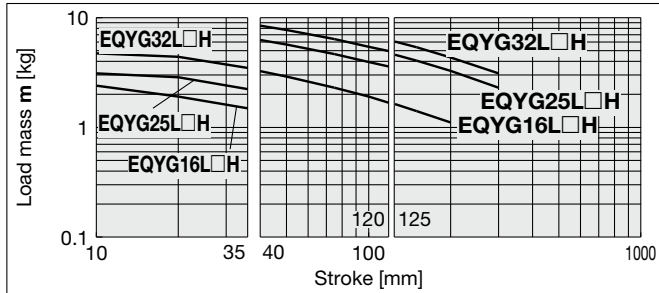

⑩ L = 100 mm Max. speed = 200 mm/s or less

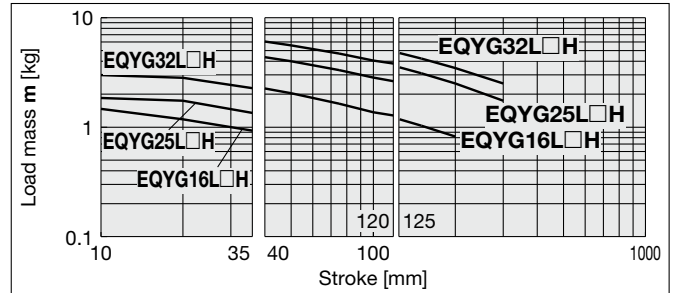

⑪ L = 50 mm Max. speed = Over 200 mm/s

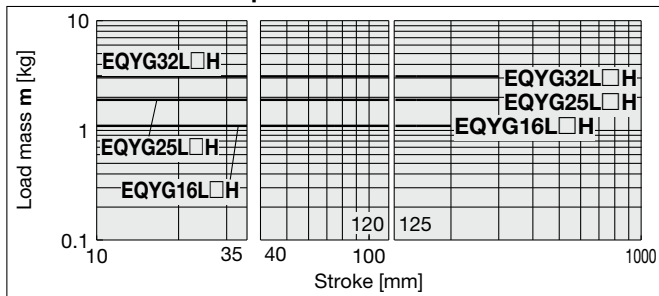

⑫ L = 100 mm Max. speed = Over 200 mm/s

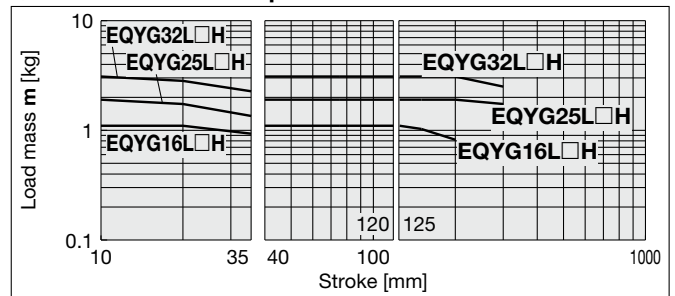

Operating Range when Used as a Stopper

EQYG□M (Sliding bearing)

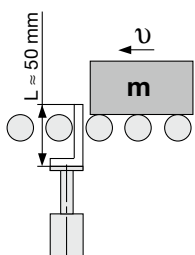

⚠ Caution

Handling Precautions

- * When used as a stopper, select a model with a stroke of 30 mm or less.
- * EQYG□L (ball bushing bearing) cannot be used as a stopper.
- * Workpiece collision in series with guide rod cannot be permitted (Fig. a).
- * The body should not be mounted on the end. It must be mounted on the top or bottom (Fig. b).

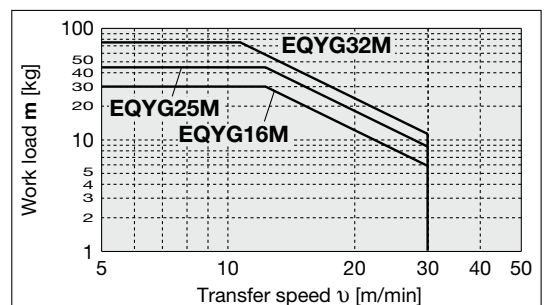
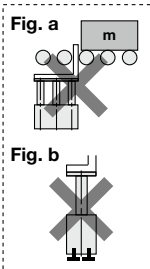

Speed-Work Load Graph (Guide)

* The following graphs show the values when the external guide is used together.

EQYG16LHA

Horizontal/Lead 10

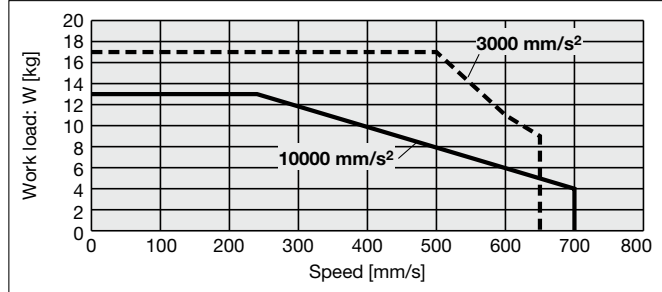

Vertical/Lead 10

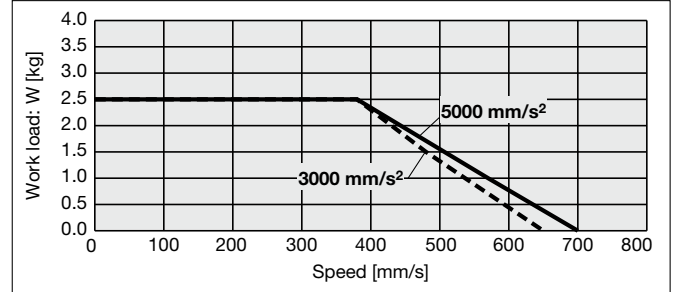

EQYG16LHB

Horizontal/Lead 5

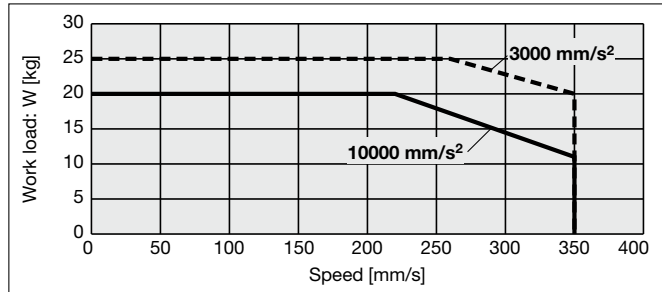

Vertical/Lead 5

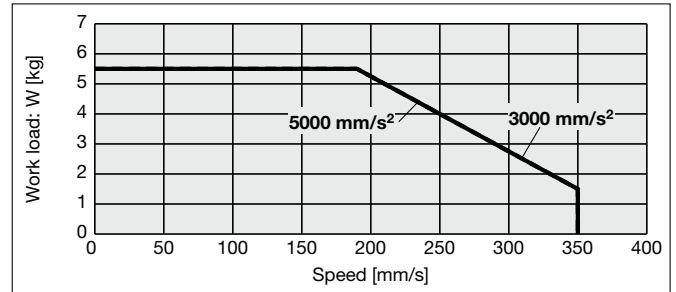

EQYG16LHC

Horizontal/Lead 2.5

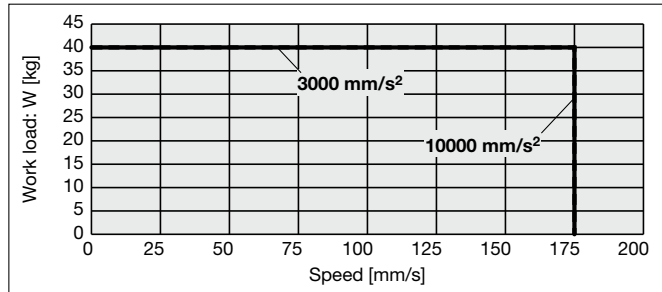

Vertical/Lead 2.5

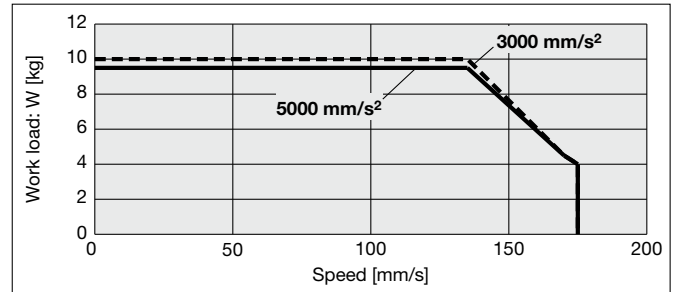

Speed-Work Load Graph (Guide)

* The following graphs show the values when the external guide is used together.

EQYG16MHA

Horizontal/Lead 10

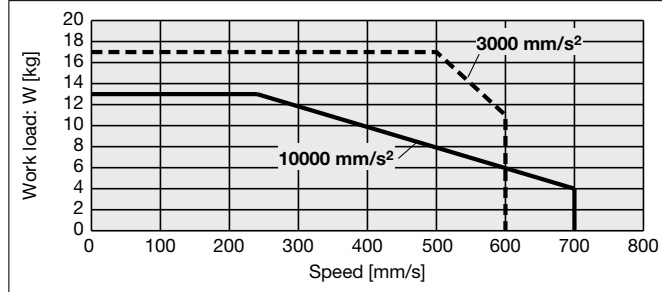

Vertical/Lead 10

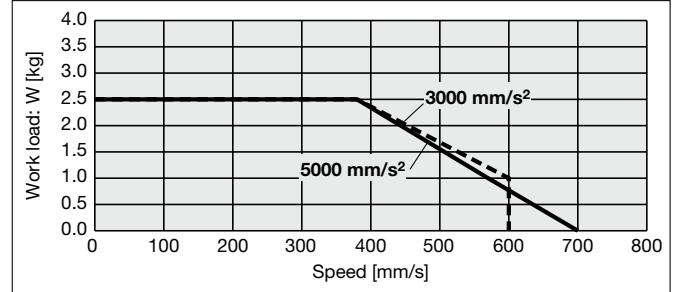

EQYG16MHB

Horizontal/Lead 5

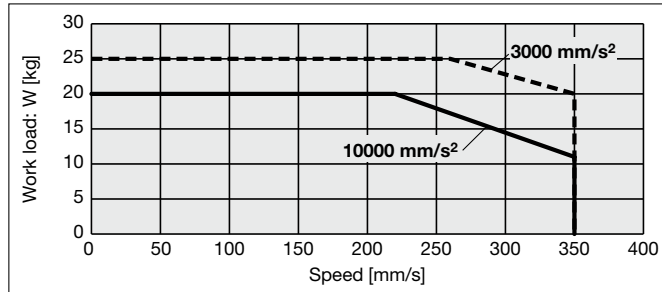

Vertical/Lead 5

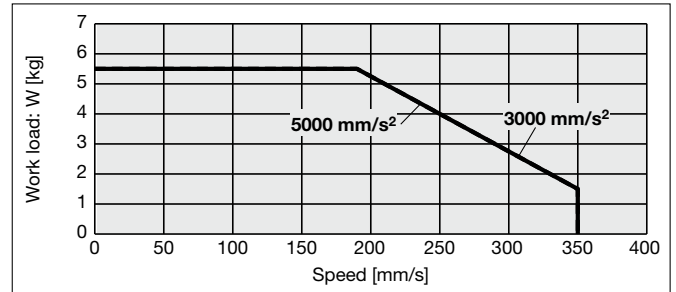

EQYG16MHC

Horizontal/Lead 2.5

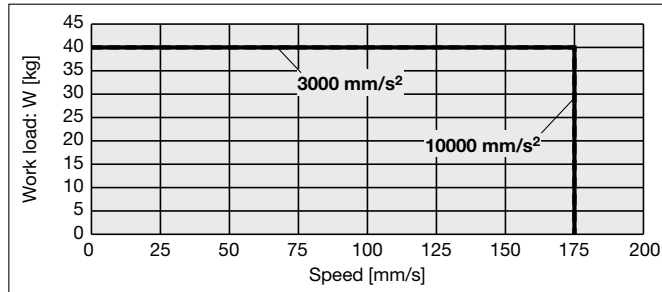

Vertical/Lead 2.5

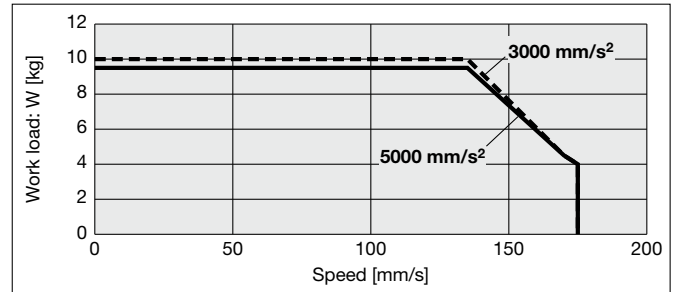

Model Selection

EQFS□H Series

EQY□H Series

EQYG□H Series

Auto Switch

Electric Specifications

Wiring Examples

Options

Speed-Work Load Graph (Guide)

* The following graphs show the values when the external guide is used together.

EQYG25LHH

Horizontal/Lead 20

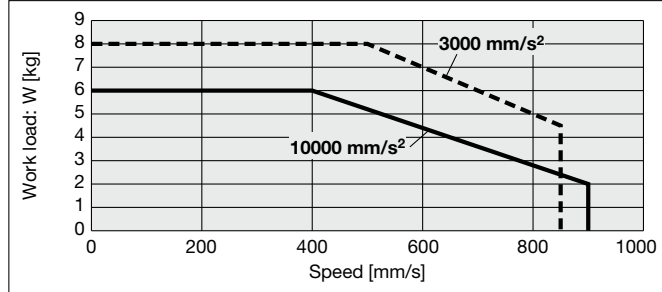

Vertical/Lead 20

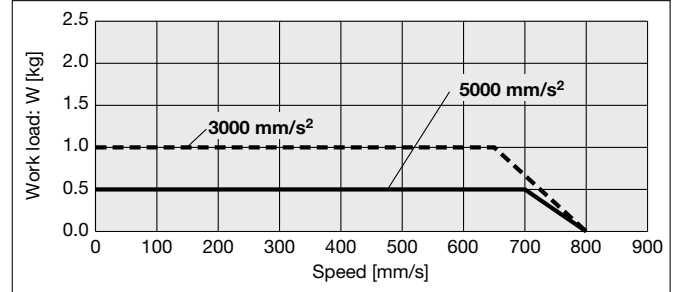

EQYG25LHA

Horizontal/Lead 12

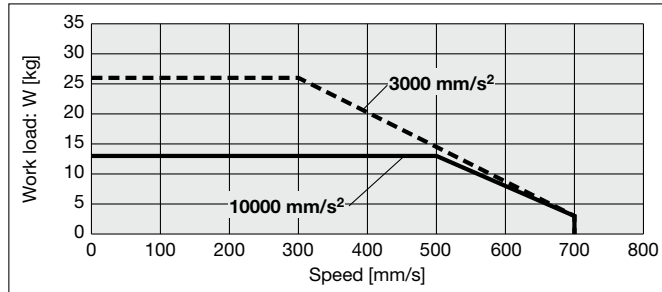

Vertical/Lead 12

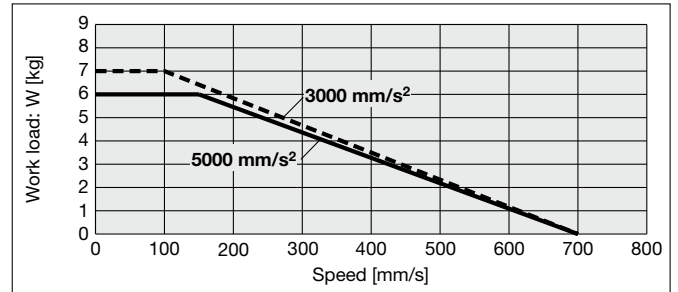

EQYG25LHB

Horizontal/Lead 6

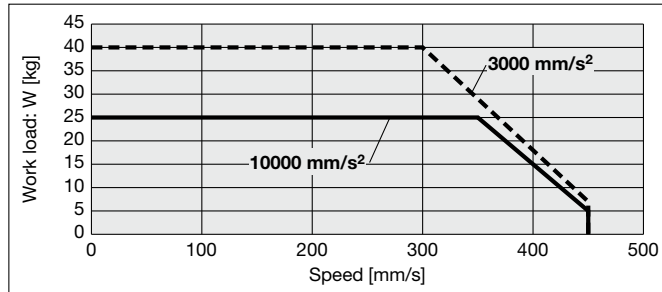

Vertical/Lead 6

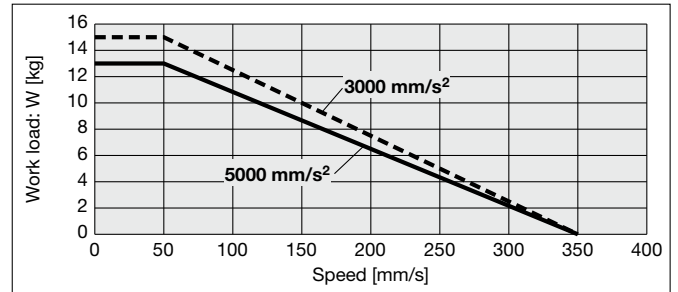

EQYG25LHC

Horizontal/Lead 3

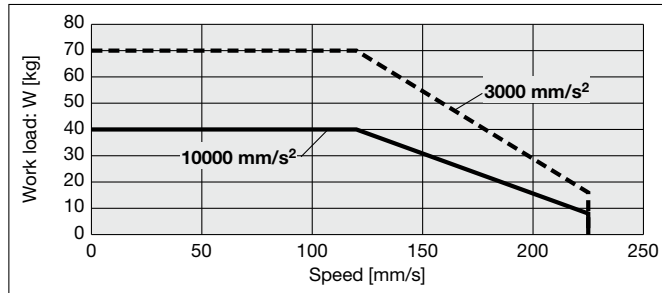

Vertical/Lead 3

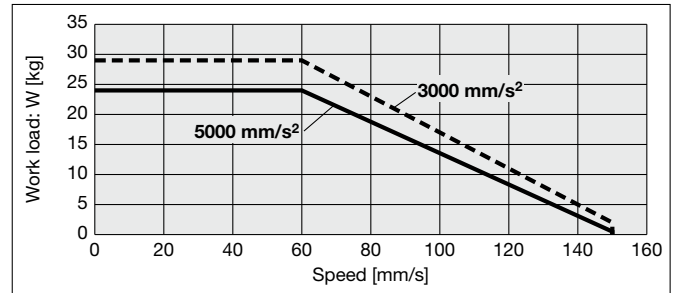

Speed-Work Load Graph (Guide)

* The following graphs show the values when the external guide is used together.

EQYG25MHH

Horizontal/Lead 20

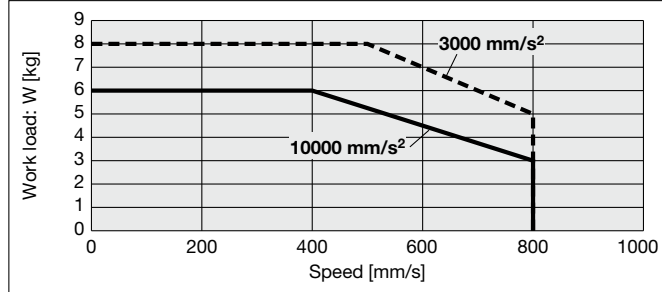

Vertical/Lead 20

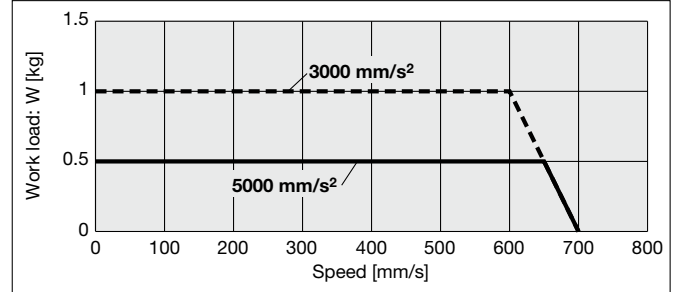

EQYG25MHA

Horizontal/Lead 12

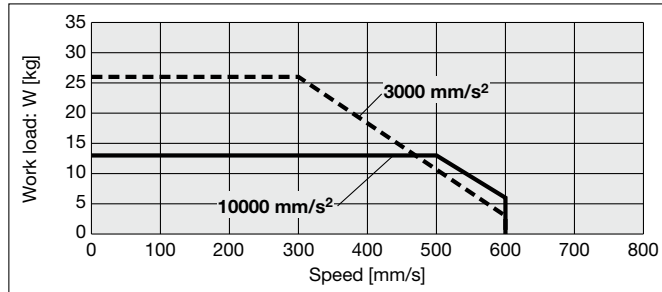

Vertical/Lead 12

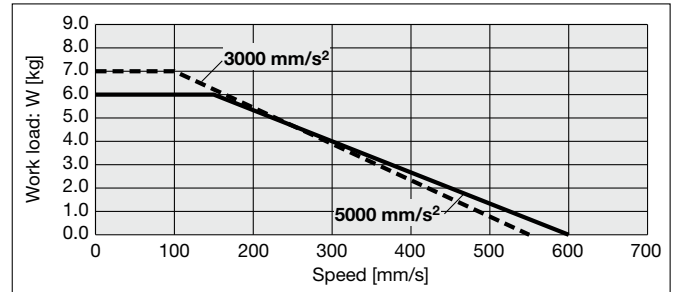

EQYG25MHB

Horizontal/Lead 6

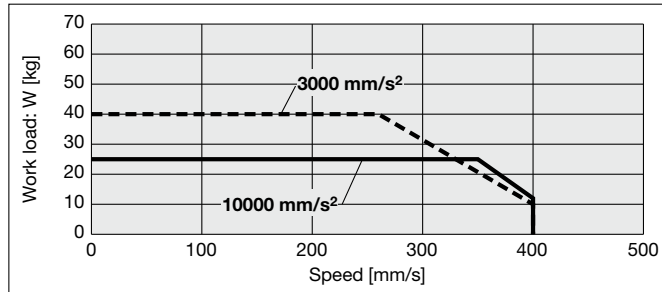

Vertical/Lead 6

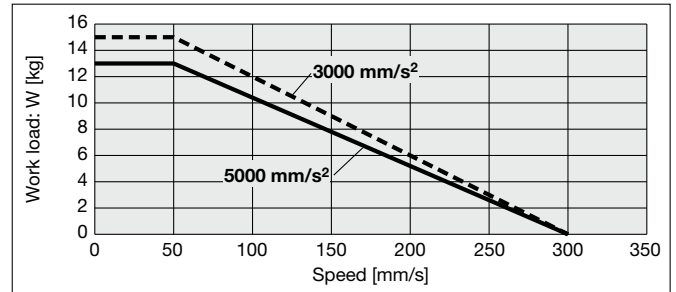

EQYG25MHC

Horizontal/Lead 3

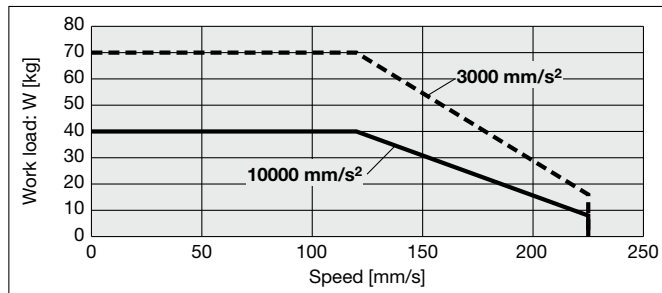

Vertical/Lead 3

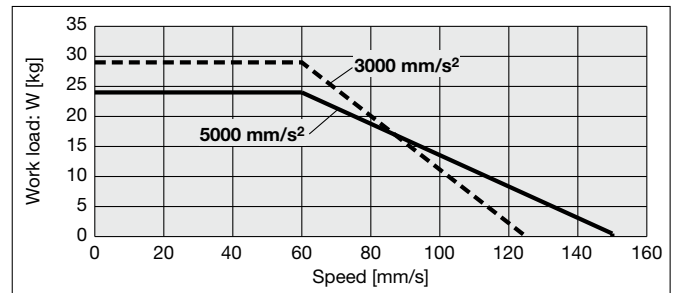

Model Selection

EQFS□H Series

EQY□H Series

EQYG□H Series

Auto Switch

Electric Specifications

Wiring Examples

Options

Speed-Work Load Graph (Guide)

* The following graphs show the values when the external guide is used together.

EQYG32LHH

Horizontal/Lead 24

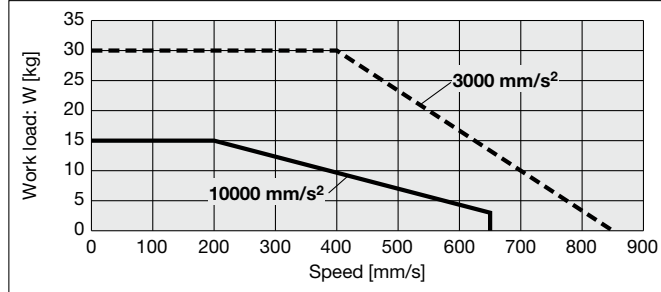

Vertical/Lead 24

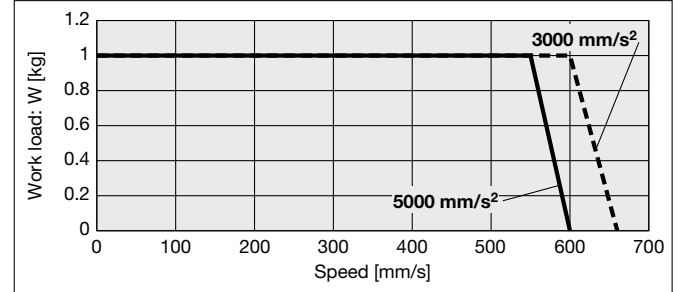

EQYG32LHA

Horizontal/Lead 16

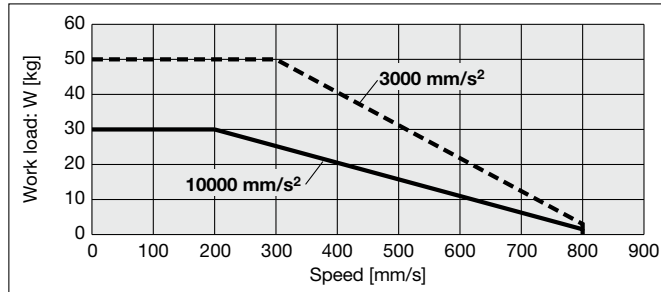

Vertical/Lead 16

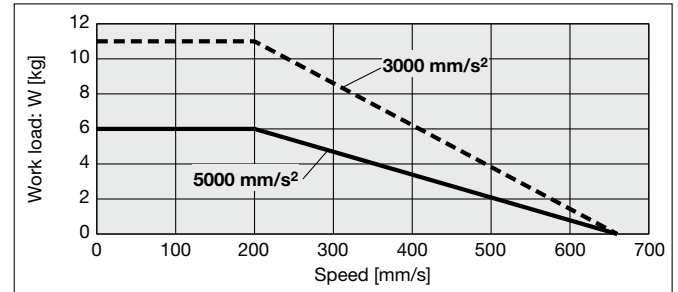

EQYG32LHB

Horizontal/Lead 8

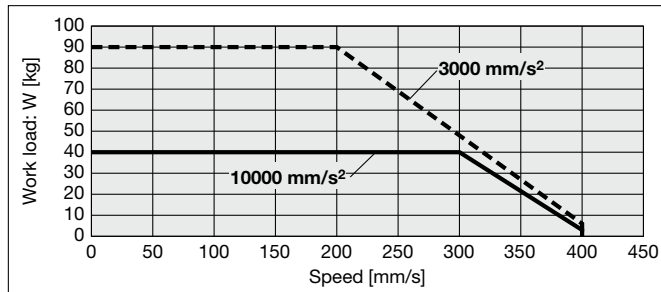

Vertical/Lead 8

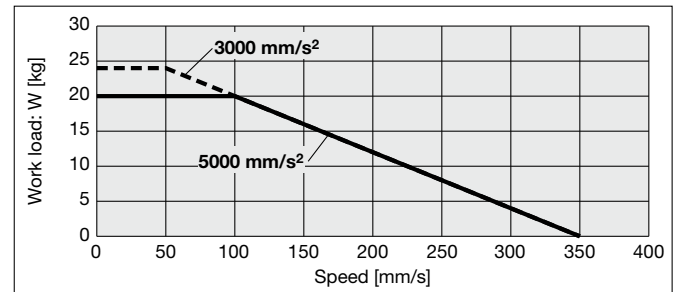

EQYG32LHC

Horizontal/Lead 4

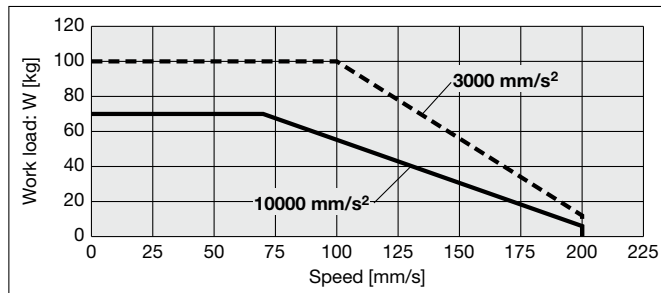

Vertical/Lead 4

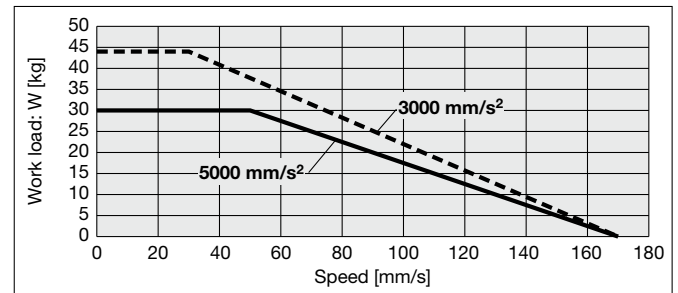

Speed-Work Load Graph (Guide)

* The following graphs show the values when the external guide is used together.

EQYG32MHH

Horizontal/Lead 24

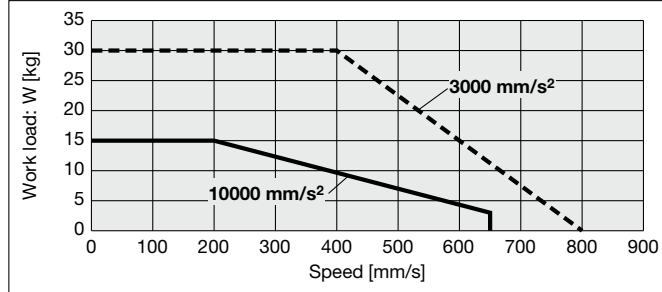

Vertical/Lead 24

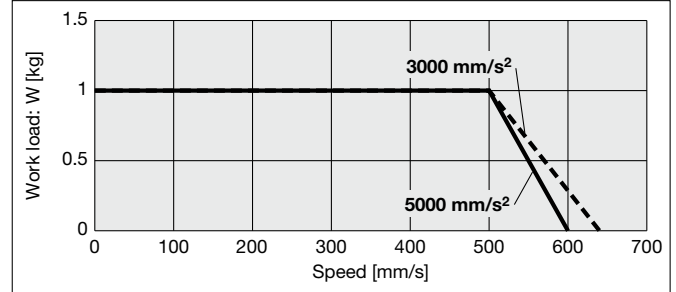

EQYG32MHA

Horizontal/Lead 16

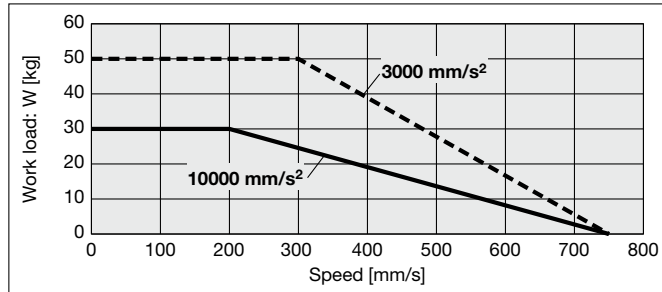

Vertical/Lead 16

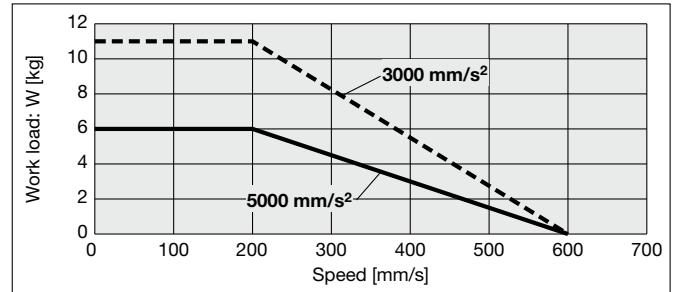

EQYG32MHB

Horizontal/Lead 8

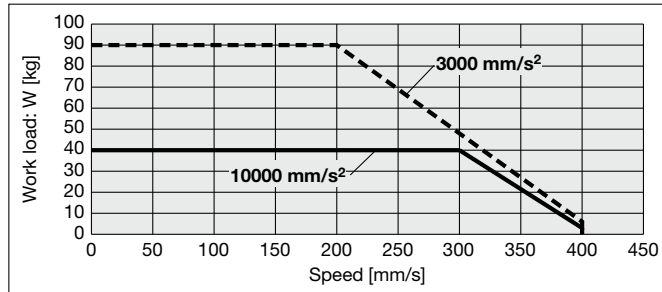

Vertical/Lead 8

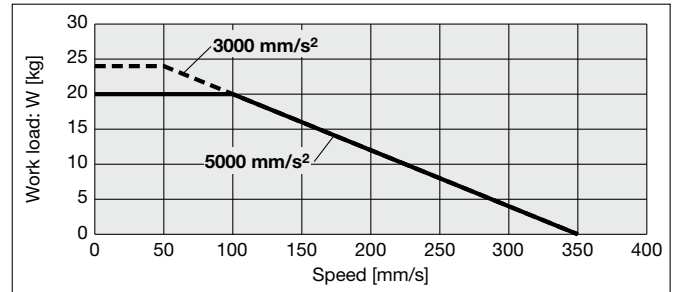

EQYG32MHC

Horizontal/Lead 4

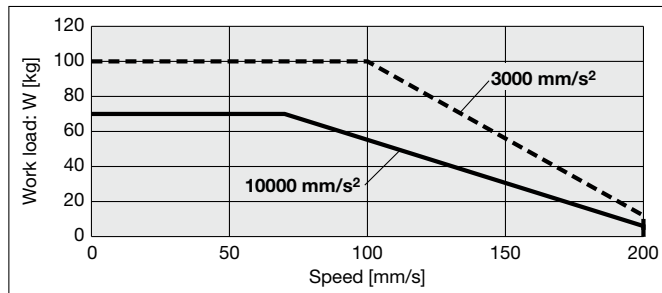

Vertical/Lead 4

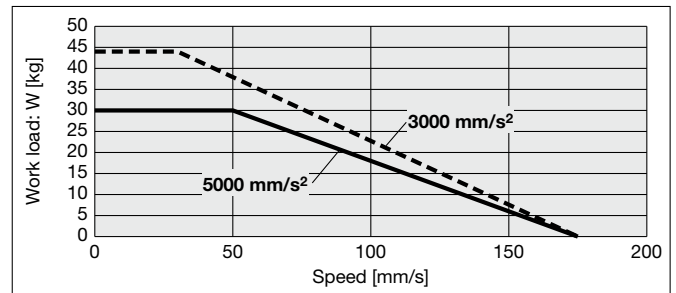

Model Selection

EQFS□H Series

EQY□H Series

EQYG□H Series

Auto Switch

Electric Specifications

Wiring Examples

Options

Allowable Rotational Torque of Plate: T

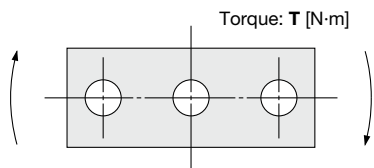

Model	Stroke [mm]					T [N·m]
	30	50	100	200	300	
EQYG16M	0.70	0.57	1.05	0.56	—	
EQYG16L	0.82	1.48	0.97	0.57	—	
EQYG25M	1.56	1.29	3.50	2.18	1.36	
EQYG25L	1.52	3.57	2.47	2.05	1.44	
EQYG32M	2.55	2.09	5.39	3.26	1.88	
EQYG32L	2.80	5.76	4.05	3.23	2.32	

Non-rotating Accuracy of Plate: θ

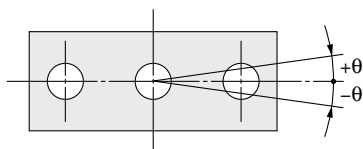

Size	Non-rotating accuracy θ	
	EQYG□M	EQYG□L
16	0.06°	0.05°
25		0.04°
32	0.05°	

Plate Displacement: δ

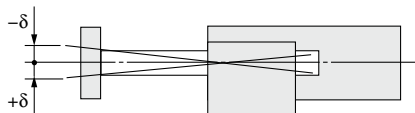

Model	Stroke [mm]					[mm]
	30	50	100	200	300	
EQYG16M	±0.20	±0.25	±0.24	±0.27	—	
EQYG16L	±0.13	±0.12	±0.17	±0.19	—	
EQYG25M	±0.26	±0.31	±0.25	±0.38	±0.36	
EQYG25L	±0.13	±0.13	±0.17	±0.20	±0.23	
EQYG32M	±0.23	±0.29	±0.23	±0.36	±0.34	
EQYG32L	±0.11	±0.11	±0.15	±0.19	±0.22	

* The values without a load are shown.

Force Conversion Graph (Guide)

EQYG16□H

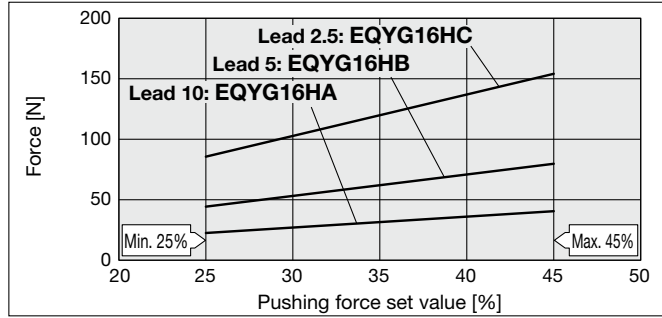

Ambient temperature	Pushing force set value [%]	Duty ratio [%]	Continuous pushing time [min]
40°C or less	45 or less	100	No restriction

EQYG25□H

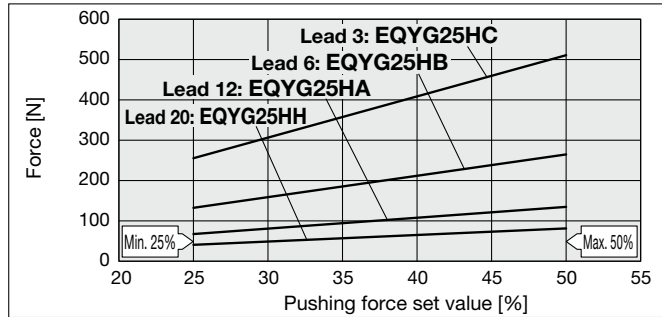

Ambient temperature	Pushing force set value [%]	Duty ratio [%]	Continuous pushing time [min]
40°C or less	50 or less	100	No restriction

EQYG32□H

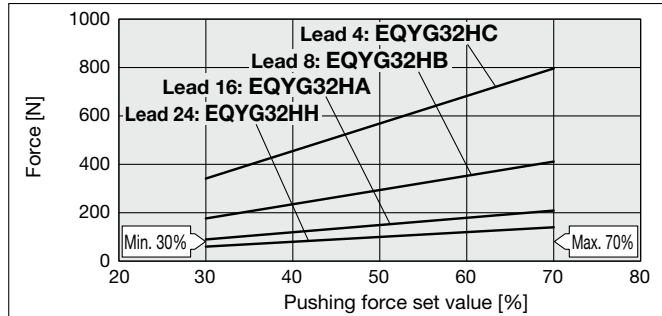

Ambient temperature	Pushing force set value [%]	Duty ratio [%]	Continuous pushing time [min]
40°C or less	70 or less	100	No restriction

<Set Values for Vertical Upward Transfer Pushing Operations>

For vertical loads (upward), set the pushing force to the max. value shown below and operate at the work load or less.

Model	EQYG16 ^M _L □			EQYG25 ^M _L □			EQYG32 ^M _L □					
	A	B	C	H	A	B	C	H	A	B	C	
Work load [kg]	0.5	1	2.5	0.5	1.5	4	9	0.5	2.5	7	16	
Pushing force	45%			50%			70%					

e-Actuator Easy to Operate

Integrated Controller / Guide Rod Type

EQYG□H Series EQYG16, 25, 32

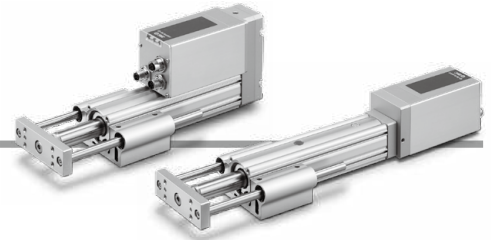

How to Order

EQYG **25** **M** **D** **H** **B** - **50** **□** - **B** **5**

①
②
③
④
⑤
⑥
⑦
⑧
⑨

① Size

16
25
32

② Bearing type

M	Sliding bearing
L	Ball bushing bearing

③ Motor mounting position/Motor cover direction*1 *2

Symbol	Motor mounting position	Motor cover direction	Size
Nil	Top side parallel	—	16/25/32
D	In-line	—	25/32
D1		Left side	16
D2		Right side	
D3		Top side	
D4		Bottom side	

④ Motor type

H	Battery-less absolute (Step motor 24 VDC)
----------	---

⑤ Lead [mm]

Symbol	EQYG16	EQYG25	EQYG32
H	—	20	24
A	10	12	16
B	5	6	8
C	2.5	3	4

⑥ Stroke [mm]

30	30
to	to
300	300

* For details, refer to the applicable stroke table below.

⑦ Motor option

Nil	Without option
B	With lock

⑧ Controller position

B	Integrated controller
----------	-----------------------

⑨ Parallel input

5	NPN
6	PNP

Applicable Stroke Table

Size	Stroke [mm]							Manufacturable stroke range
	30	50	100	150	200	250	300	
16	●	●	●	●	●	—	—	10 to 200
25	●	●	●	●	●	●	●	15 to 300
32	●	●	●	●	●	●	●	20 to 300

*1 Motor mounting position: For the parallel mounting type, the motor units with the following sizes and strokes protrude from the body end. Check for interference with workpieces before selecting a model.

- EQYG16 Without lock: 30 mm stroke, With lock: 30, 50 mm strokes
- EQYG25 Without lock: 30 mm stroke, With lock: 30, 50 mm strokes
- EQYG32 Without lock: 30 mm stroke, With lock: 30, 50 mm strokes

*2 There is a limit for mounting size 25/32 top side parallel motor types and strokes of 100 mm or less.

For details on auto switches, refer to pages 51 to 54.

Use of auto switches for the guide rod type/EQYG

- Auto switches must be inserted from the front side with the rod (plate) sticking out.
- Auto switches cannot be mounted behind the guide attachment (in the bottom groove on the side of the rod that sticks out).
- Contact SMC when mounting an auto switch in the bottom groove on the side of the rod that sticks out is required, as this is only available as a special order.

Specifications

Model		EQYG16 ^M □H			EQYG25 ^M □H				EQYG32 ^M □H				
Actuator specifications	Stroke [mm]	30 to 200			30 to 300				30 to 300				
	Work load [kg]*1	Horizontal	17	25	40	8	26	40	70	30	50	90	100
		Vertical	2.5	5.5	10	1	7	15	29	1	11	24	44
	Pushing force [N]*2 *3 *4		23 to 41	44 to 80	86 to 154	41 to 81	67 to 15	132 to 265	255 to 511	60 to 140	90 to 209	176 to 411	341 to 796
	Speed [mm/s]		15 to 700	8 to 350	4 to 175	30 to 900	18 to 700	9 to 450	5 to 225	30 to 850	24 to 800	12 to 400	6 to 200
	Max. acceleration/ deceleration [mm/s ²]	Horizontal	10000										
		Vertical	5000										
	Pushing speed [mm/s ²]*5		25			35				30			
	Positioning repeatability [mm]		±0.02										
	Lost motion [mm]*6		0.1 or less										
	Lead [mm]		10	5	2.5	20	12	6	3	24	16	8	4
	Impact/Vibration resistance [m/s ²]*7		50/20										
	Actuation type		Ball screw + Belt (EQYG□□H), Ball screw (EQYG□□DH)										
	Guide type		Sliding bearing (EQYG□M), Ball bushing bearing (EQYG□L)										
Operating temperature range [°C]		5 to 40											
Operating humidity range [%RH]		90 or less (No condensation)											
Enclosure		IP40											
Electric specifications	Motor size	□28			□42				□56.4				
	Motor type	Battery-less absolute (Step motor 24 VDC)											
	Encoder	Battery-less absolute encoder											
	Power supply voltage [V]	24 VDC ±10%											
Lock unit specifications	Power [W]*8 *9	Max. power 82			Max. power 86				Max. power 109				
	Type*10	Non-magnetizing lock											
	Holding force [N]	25	54	98	10	69	147	284	10	108	235	431	
	Power [W]*9	2.9			5				5				
	Rated voltage [V]	24 VDC ±10%											

- *1 Horizontal: Please use an external guide (friction coefficient: 0.1 or less). The work load shows the maximum value. The actual work load and transfer speed change according to the condition of the external guide.
 For the speed, acceleration, and duty ratio according to the work load, check the "Speed-Work Load Graph" in the catalog.
 Vertical: If the rod orientation is vertical or radial load is applied to the rod, please use an external guide (friction coefficient: 0.1 or less). The work load represents the maximum value. The actual work load and transfer speed change according to the condition of the external guide.
 For the speed, acceleration, and duty ratio according to the work load, check the "Speed-Work Load Graph" in the catalog.
 The values shown in () are the max. acceleration/deceleration.
 Set the acceleration/deceleration speed to 10000 [mm/s²] or less for the horizontal direction and 5000 [mm/s²] or less for the vertical direction.
- *2 Pushing force accuracy is ±20% (F.S.).
- *3 The pushing force set values for EQYG16□H are 25% to 45%, for EQYG25□H are 25% to 50%, and for EQYG32□H are 30% to 70%.
 The pushing force values change according to the duty ratio and pushing speed. Check the "Force Conversion Graph" on page 66.
- *4 The speed and force may change depending on the cable length, load, and mounting conditions. Furthermore, if the cable length exceeds 5 m, then it will decrease by up to 10% for each 5 m. (At 15 m: Reduced by up to 20%)
- *5 The allowable speed for pushing operation. When push conveying a workpiece, operate at the vertical work load or less.
- *6 A reference value for correcting errors in reciprocal operation
- *7 Impact resistance: No malfunction occurred when the actuator was tested with a drop tester in both an axial direction and a perpendicular direction to the lead screw. (The test was performed with the actuator in the initial state.)
 Vibration resistance: No malfunction occurred in a test ranging between 45 to 2000 Hz. The test was performed in both an axial direction and a perpendicular direction to the lead screw. (The test was performed with the actuator in the initial state.)
- *8 Indicates the max. power during operation (including the controller). This value can be used for the selection of the power supply.
- *9 For an actuator with lock, add the power for the lock.
- *10 With lock only

Weight

Top Side Parallel Motor

Series	EQYG16M□H					EQYG25M□H							EQYG32M□H						
Stroke [mm]	30	50	100	150	200	30	50	100	150	200	250	300	30	50	100	150	200	250	300
Product weight [kg]	1.10	1.23	1.48	1.79	2.02	2.23	2.42	2.74	3.16	3.50	3.84	4.10	3.56	3.82	4.37	4.93	5.60	6.09	6.53
Additional weight with lock [kg]	0.19					0.31							0.58						

Series	EQYG16L□H					EQYG25L□H							EQYG32L□H						
Stroke [mm]	30	50	100	150	200	30	50	100	150	200	250	300	30	50	100	150	200	250	300
Product weight [kg]	1.11	1.23	1.42	1.73	1.94	2.24	2.45	2.69	3.12	3.38	3.70	3.94	3.56	3.83	4.22	4.77	5.31	5.82	6.21
Additional weight with lock [kg]	0.19					0.31							0.58						

In-line Motor

Series	EQYG16M□H					EQYG25M□H							EQYG32M□H						
Stroke [mm]	30	50	100	150	200	30	50	100	150	200	250	300	30	50	100	150	200	250	300
Product weight [kg]	1.09	1.21	1.46	1.77	2.01	2.09	2.28	2.60	3.02	3.36	3.70	3.96	3.37	3.63	4.18	4.74	5.41	5.90	6.34
Additional weight with lock [kg]	0.19					0.31							0.58						

Series	EQYG16L□H					EQYG25L□H							EQYG32L□H						
Stroke [mm]	30	50	100	150	200	30	50	100	150	200	250	300	30	50	100	150	200	250	300
Product weight [kg]	1.10	1.21	1.40	1.71	1.93	2.10	2.31	2.55	2.98	3.24	3.56	3.80	3.37	3.64	4.03	4.58	5.12	5.63	6.02
Additional weight with lock [kg]	0.19					0.31							0.58						

Model Selection

EQFS□H Series

EQY□H Series

EQYG□H Series

Auto Switch

Electric Specifications

Wiring Examples

Options

Construction

Top side parallel motor

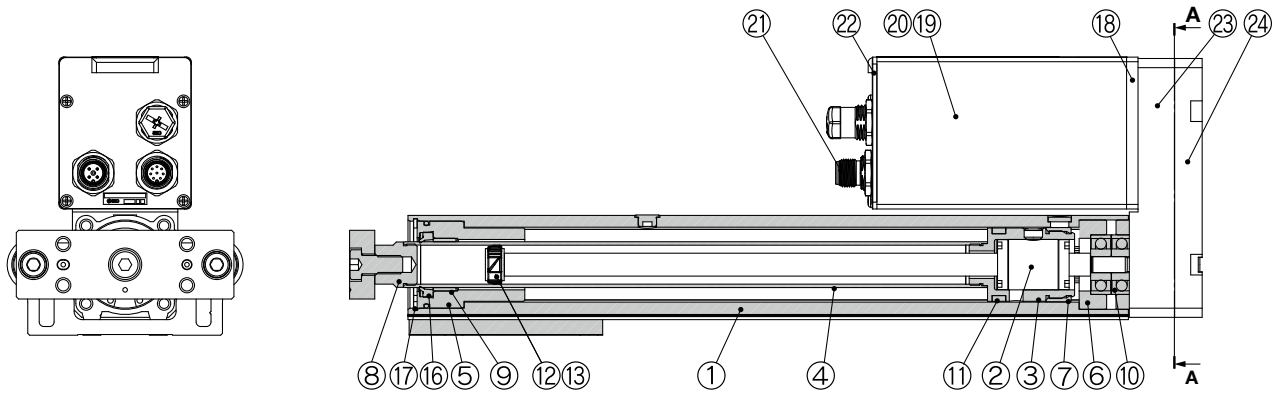

A-A

In-line motor

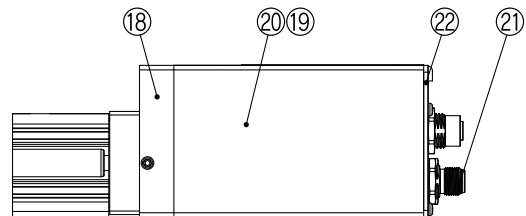

Construction

EQYG□M

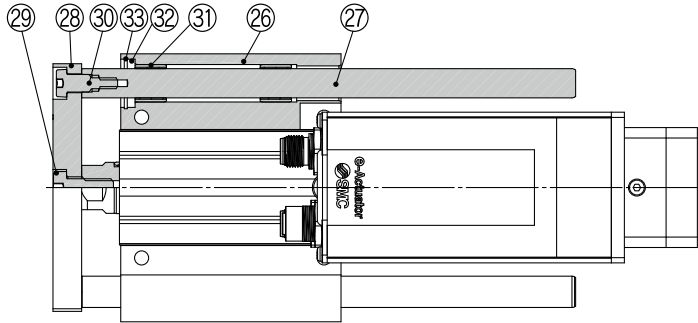

EQYG□M: 50st or less

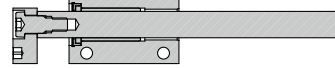

EQYG□M: Over 50st



EQYG□L

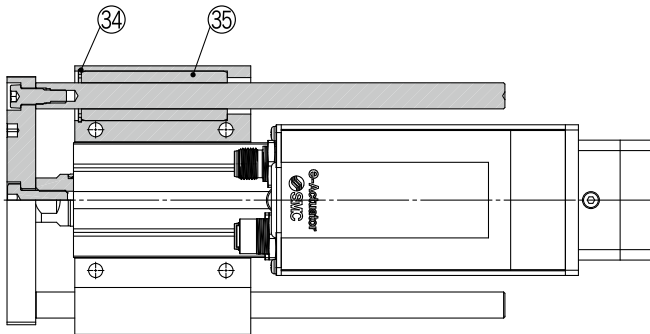

EQYG16L: 30st or less

EQYG²⁵/₃₂L: 100st or less

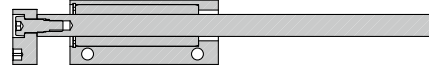

EQYG16L: Over 30st, 100st or less

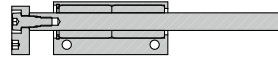

EQYG□L: Over 100st

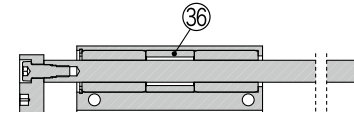

Component Parts

No.	Description	Material	Note
1	Body	Aluminum alloy	Anodized
2	Ball screw assembly	—	
3	Piston	Aluminum alloy	
4	Piston rod	Stainless steel	Hard chrome plating
5	Rod cover	Aluminum alloy	
6	Bearing holder	Aluminum alloy	
7	Rotation stopper	Synthetic resin	
8	Socket (Female thread)	Free cutting carbon steel	Nickel plating
9	Bushing	Bearing alloy	
10	Bearing	—	
11	Magnet	—	
12	Wear ring holder	Stainless steel	101 mm stroke or more
13	Wear ring	Synthetic resin	101 mm stroke or more
14	Screw pulley/hub	Aluminum alloy	
15	Motor pulley/hub	Aluminum alloy	
16	Seal	NBR	
17	Retaining ring	Steel for spring	
18	Motor adapter	Aluminum alloy	Anodized
19	Motor	—	
20	Motor cover	Aluminum alloy	Anodized
21	Connector	—	
22	End cover	Aluminum alloy	Anodized
23	Return box	Aluminum die-casted	Coating
24	Return plate	Aluminum die-casted	Coating
25	Belt	—	
26	Guide attachment	Aluminum alloy	Anodized
27	Guide rod	Carbon steel	
28	Plate	Aluminum alloy	Anodized

No.	Description	Material	Note
29	Plate mounting cap screw	Carbon steel	Nickel plating
30	Guide cap screw	Carbon steel	Nickel plating
31	Sliding bearing	Bearing alloy	
32	Soft wiper	Felt	
33	Holder	Synthetic resin	
34	Retaining ring	Steel for spring	Phosphate coating
35	Ball bushing	—	
36	Spacer	Aluminum alloy	Chromating

Replacement Parts (Top side parallel only)/Belt

No.	Size	Order no.
25	16	LE-D-2-7
	25	LE-D-19-3
	32	LE-D-19-4

Replacement Parts/Grease Pack

Applied portion	Order no.
Piston rod	GR-S-010 (10 G) GR-S-020 (20 G)

Model Selection

EQFS□H Series

EQY□H Series

EQYG□H Series

Auto Switch

Electric Specifications

Wiring Examples

Options

Dimensions: Top Side Parallel Motor

EQYG16H

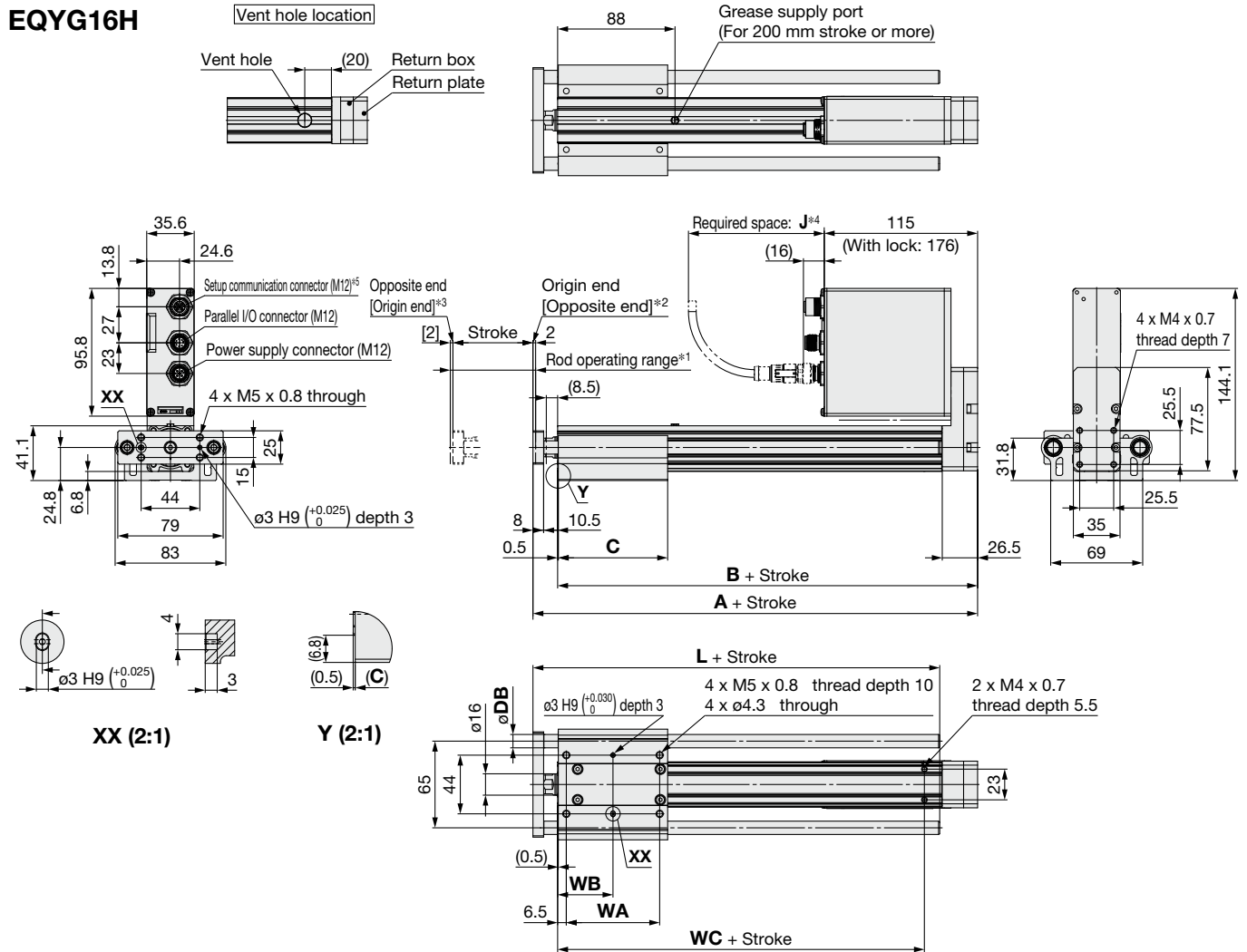

Required Space ^{*4} [mm]	
Cable connector type	J
Straight	115

* The right angled type connector cannot be used.

- *1 The range of movement of the rod according to the movement instructions. Make sure that workpieces mounted on the rod do not interfere with other workpieces or the facilities around the rod.
- *2 Indicates the factory default origin position (0 mm)
- *3 [] refers to when the rotation direction reference is changed.
- *4 The amount of space required to connect the various cables and mount the product. Provide this amount of space for cable handling.
- *5 A female dustproof cap comes with the setup communication connector (M12).

EQYG16M, EQYG16L Common

Stroke [mm]	A	B	C	WA	WB	WC
30	113.5	95	37	25	19	55
50, 100			52	40	26.5	
150, 200	133.5	115	82	70	41.5	75

EQYG16M (Sliding bearing) [mm]

Stroke [mm]	L	DB
30, 50	51.5	10
100	74.5	
150, 200	105	

EQYG16L (Ball bushing bearing) [mm]

Stroke [mm]	L	DB
30, 50, 100	75	8
150, 200	105	

Dimensions: Top Side Parallel Motor

**EQYG 25
32**

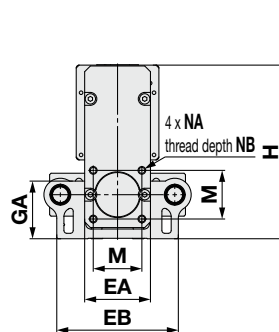
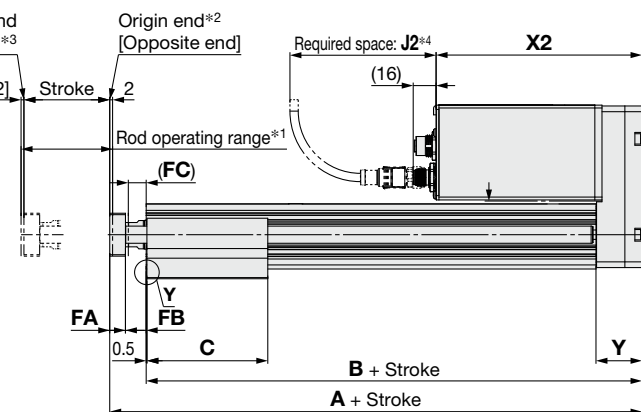
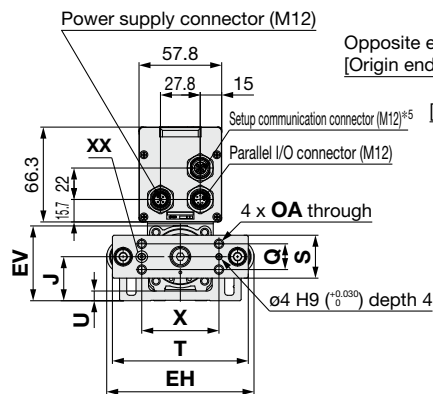
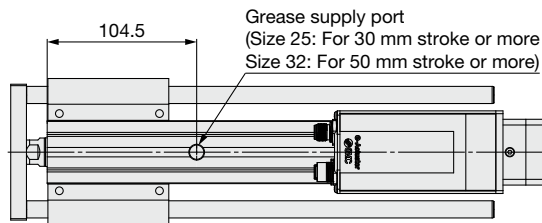
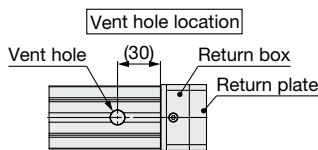

EQYG□M (Sliding bearing) [mm]

Size	Stroke range	L	DB
25	30, 50	67.5	12
	100, 150	100.5	
	200, 250, 300	138	
32	30, 50	74	16
	100, 150	107	
	200, 250, 300	144	

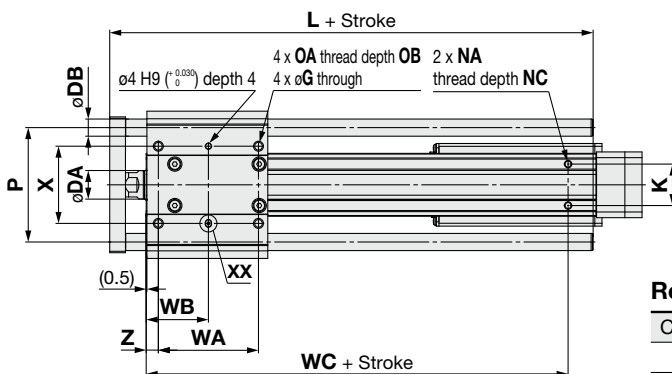

Required Space*4 [mm]

Cable connector type	J2
Straight	115

EQYG□L (Ball bushing bearing) [mm]

Size	Stroke range	L	DB
25	30, 50, 100	91	10
	150	115	
	200, 250, 300	133	
32	30, 50, 100	97.5	13
	150	116.5	
	200, 250, 300	134	

*1 The range of movement of the rod according to the movement instructions. Make sure that workpieces mounted on the rod do not interfere with other workpieces or the facilities around the rod.
 *2 Indicates the factory default origin position (0 mm)
 *3 [] refers to when the rotation direction reference is changed.

*4 The amount of space required to connect the various cables and mount the product. Provide this amount of space for cable handling.
 *5 A female dustproof cap comes with the setup communication connector (M12).
 * Through holes cannot be used for sizes 25 and 32 with the following conditions.
 Without lock: 50 mm stroke or less
 With lock: 100 mm stroke or less

EQYG□M, EQYG□L Common

Size	Stroke range	A	B	C	DA	EA	EB	EH	EV	FA	FB	FC	G	GA	H	J	K	M	NA			
																				WB	WC	X
				NC	OA	OB	P	Q	S	T	U	WA	WB	WC	X	Without lock	With lock	XA	XB	Y	Z	
25	30			50								35	26	70								
	50, 100	147.5	122	67.5	20	46	85	103	52.3	11	14.5	12.5	5.4	40.3	121.4	30.8	29	34	M5 x 0.8			
	150, 200			84.5																		
	250, 300	172.5	147	102																		
32	30			55																		
	50, 100	166	135.5	68	25	60	101	123	63.8	12	18.5	16.5	5.4	50.3	149.6	38.3	30	40	M6 x 1.0			
	150, 200			85																		
	250, 300	196	165.5	102																		
25	30												35	26								
	50, 100	7	6.5	M6 x 1.0	12	80	18	30	95	6.8			50	33.5	70	54	144	184	4	5	32.2	8.5
	150, 200												70	43.5								
	250, 300												85	51	95							
														40	28.5	75						
32	30												40	28.5								
	50, 100	10	8.5	M6 x 1.0	12	95	28	40	117	7.3			50	33.5	75	64	144	189	5	6	39.1	8.5
	150, 200												70	43.5								
	250, 300												85	51	105							

Model Selection
 EQFS□H Series
 EQY□H Series
 EQYG□H Series

Auto Switch
 Electric Specifications
 Wiring Examples
 Options

Dimensions: In-line Motor

EQYG²⁵₃₂DH

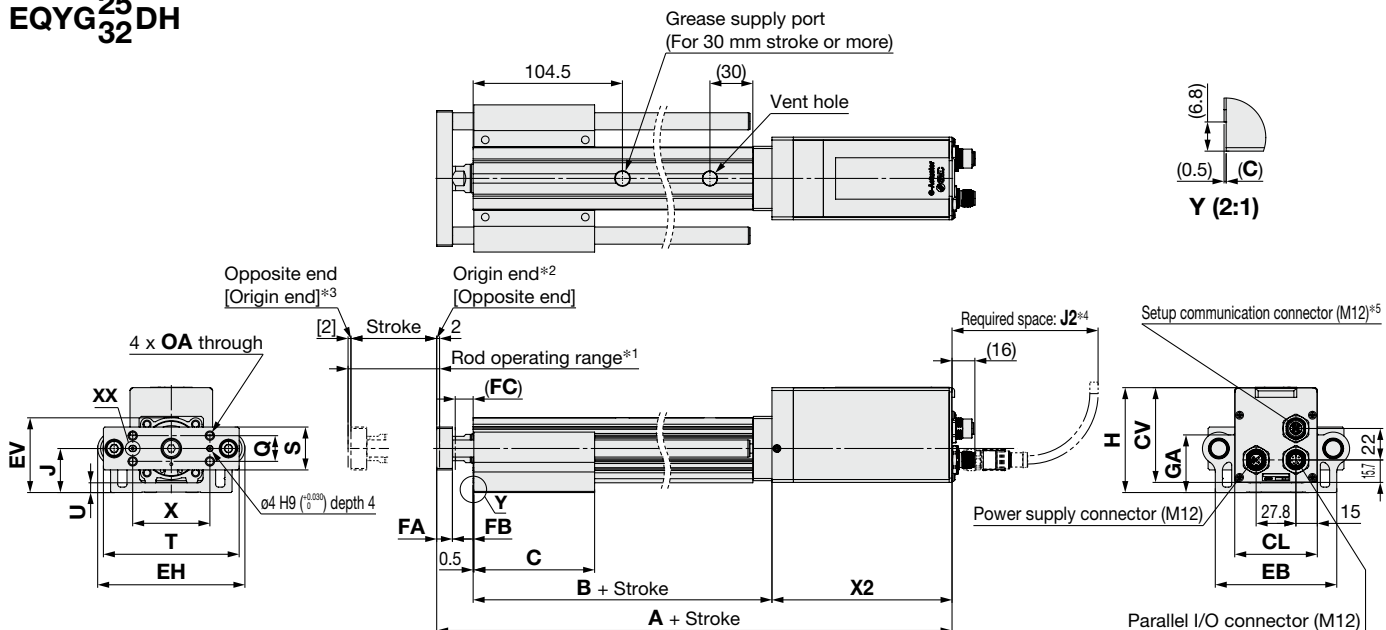

EQYG□M (Sliding bearing) [mm]

Size	Stroke range	L	DB
25	30, 50	67.5	12
	100, 150	100.5	12
	200, 250, 300	138	12
32	30, 50	74	16
	100, 150	107	16
	200, 250, 300	144	16

EQYG□L (Ball bushing bearing) [mm]

Size	Stroke range	L	DB
25	30, 50, 100	91	10
	150	115	10
	200, 250, 300	133	10
32	30, 50, 100	97.5	13
	150	116.5	13
	200, 250, 300	134	13

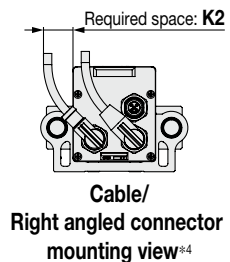
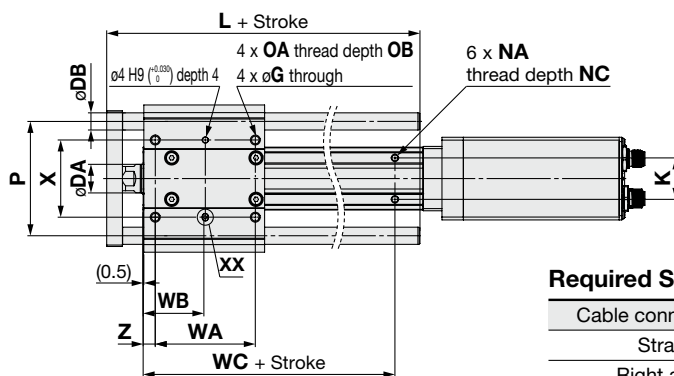

Required Space*4 [mm]

Cable connector type	J2	K2
Straight	115	—
Right angled	50*6	25

*6 Secure a space of 100 mm or more to connect the communication cable for controller setting.

- *1 The range of movement of the rod according to the movement instructions. Make sure that workpieces mounted on the rod do not interfere with other workpieces or the facilities around the rod.
- *2 Indicates the factory default origin position (0 mm)
- *3 [] refers to when the rotation direction reference is changed.
- *4 The amount of space required to connect the various cables and mount the product. Provide this amount of space for cable handling.
- *5 A female dustproof cap comes with the setup communication connector (M12).

EQYG□M, EQYG□L Common

Size	Stroke range	A		B	C	CL	CV	DA	EB	EH	EV	FA	FB	FC	G	GA	H	J	K
		Without lock	With lock																
25	30	254.5	294.5	103	50	57.8	66.3	20	85	103	52.3	11	14.5	12.5	5.4	40.3	73.4	30.8	29
	50, 100				67.5														
	150, 200				84.5														
	250, 300				102														
32	30	270	315	116.5	55	69.8	83.5	25	101	123	63.8	12	18.5	16.5	5.4	50.3	91.1	38.3	30
	50, 100				68														
	150, 200				85														
	250, 300				102														

Size	Stroke range	NA	NC	OA	OB	P	Q	S	T	U	WA	WB	WC	X	X2		XA	XB	Y	Z
															Without lock	With lock				
25	30	M5 x 0.8	6.5	M6 x 1.0	12	80	18	30	95	6.8	35	26	70	54	126	166	4	5	32.2	8.5
	50, 100										50	33.5								
	150, 200										70	43.5								
	250, 300										85	51								
32	30	M6 x 1.0	8.5	M6 x 1.0	12	95	28	40	117	7.3	40	28.5	75	64	123	168	5	6	39.1	8.5
	50, 100										50	33.5								
	150, 200										70	43.5								
	250, 300										85	51								

Model Selection
 EQFS□H Series
 EQY□H Series
 EQYG□H Series
 Auto Switch
 Electric Specifications
 Wiring Examples
 Options

Support Block

● Guide for support block application

When the stroke exceeds 100 mm and the mounting orientation is horizontal, the body will be bent. Mounting the support block is recommended. (Please order it separately from the models shown below.)

Support Block Model

LEYG-S016

● **Size**

016	For size 16
025	For size 25
032	For size 32

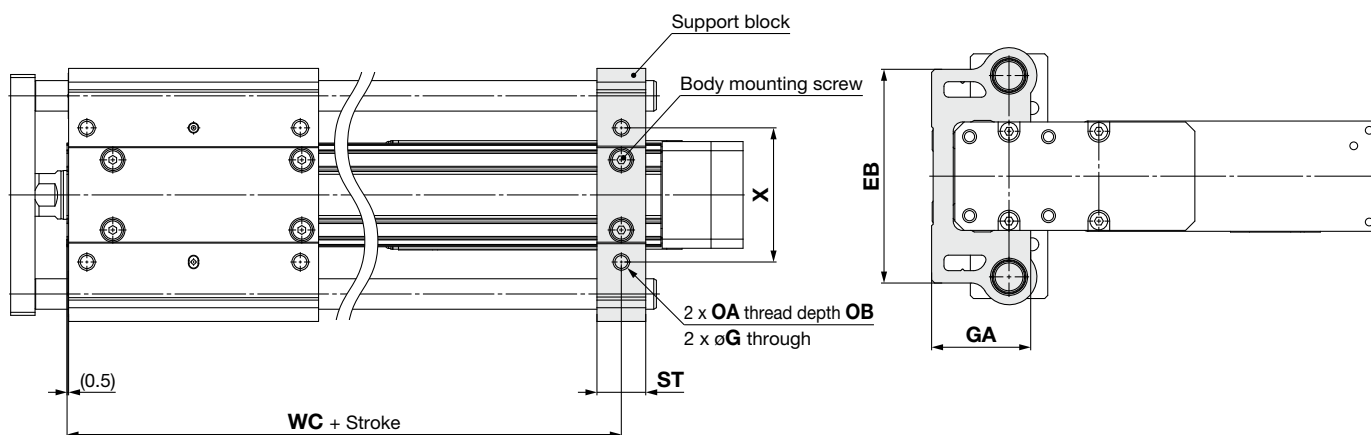
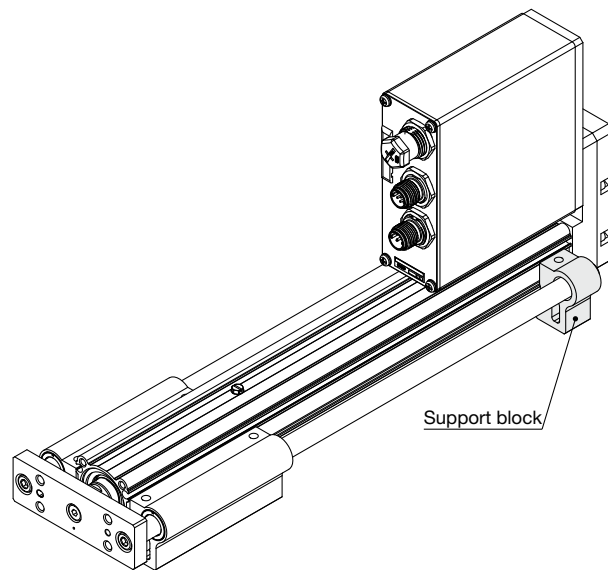

⚠ Caution

Do not install the body using only a support block.
 The support block should be used only for support.

Size	Model	Stroke range	EB	G	GA	OA	OB	ST	WC	X
16	LEYG-S016	Up to 100	69	4.3	31.8	M5 x 0.8	10	16	55	44
		105 to 200							75	
25	LEYG-S025	Up to 100	85	5.4	40.3	M6 x 1.0	12	20	70	54
		105 to 300							95	
32	LEYG-S032	Up to 100	101	(5.4)	(50.3)	M6 x 1.0	12	22	75	64
		105 to 300							105	

* Two body mounting screws are included with the support block.

* The through holes of the LEYG-S025 and LEYG-S032 cannot be used for the top side parallel motor type. Use taps on the bottom.

Slider Type

Rod Type

Guide Rod Type

EQFS **H/EQY** **H/EQYG** **H Series**

e-Actuator Electric Specifications

Compatible motor		Step motor 24 VDC
Power supply		24 VDC $\pm 10\%$
Compatible encoder		Battery-less absolute
Parallel input specifications	Number of inputs	3 inputs (Non-insulated)
	Input voltage	24 VDC $\pm 10\%$
	Input current	5 mA/circuit
Parallel output specifications	Number of outputs	4 outputs (Non-insulated)
	Load voltage	24 VDC $\pm 10\%$
	Max. load current	40 mA/point
LED		PWR (Green), ALM (Red), OVL (Orange)

The initial setting of the e-Actuator at the time of shipment from the factory is the closed center mode.

To switch the setting to single or double solenoid mode, switch the mode by using the e-Actuator setup software.

Model Selection

EQFS H SeriesEQY H SeriesEQYG H Series

Auto Switch

Electric Specifications

Wiring Examples

Options

Slider Type Rod Type Guide Rod Type
EQFS □ H/EQY □ H/EQYG □ H Series
Wiring Examples

- * The wiring examples are shown below. Refer to the EQFS/EQY/EQYG operation manual for details.
- * Use the I/O cable (JX-CI□-E-□-S) for connecting a PLC with the parallel I/O connector.
- * Wiring depends on the parallel input/output type (NPN or PNP).
- * The parallel I/O is of non-insulated specification.
 The ground connection of the connected PLC and other equipment uses a common GND with the GND of the power supply connector.

Wiring diagram (NPN)

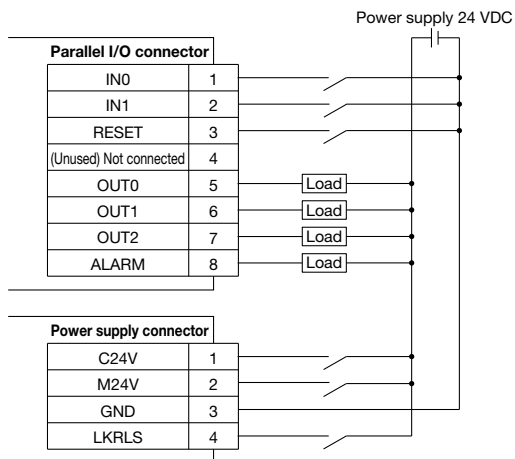

Wiring diagram (PNP)

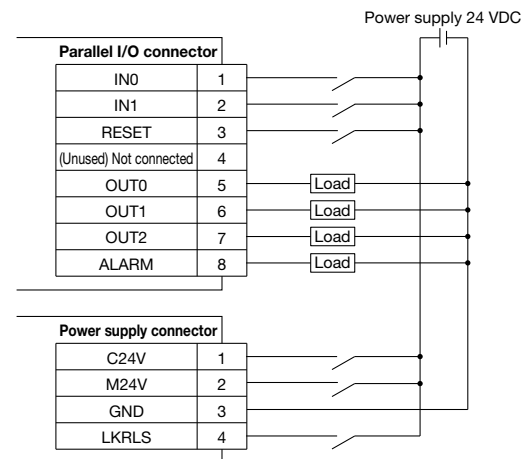

Input Signal

Name	Details
IN0*1	Movement signal for origin end
IN1*1	Movement signal for opposite end
RESET	Reset alarms

*1 In single solenoid mode, turning ON of IN1 input gives an opposite end operation instruction, turning OFF of IN1 input gives an origin end operation instruction, and IN0 is not used.

Output Signal

Name	Details
OUT0	Origin end position detection
OUT1	Opposite end position detection
OUT2	Midpoint position detection
*ALARM*1	OFF when alarm is generated

*1 Signal of negative-logic circuit
 * Check the catalog and operation manual of each actuator model which is capable of performing pushing operations.
 The "Specifications" table for models which are capable of performing pushing operations includes an item for the pushing force.

Slider Type Rod Type Guide Rod Type
EQFS □ H/EQY □ H/EQYG □ H Series
Options

■ Communication cable for controller setting

Controller setting kit JX-CT-E

A set which includes a communication cable (JX-CTC-E) and a USB cable (LEC-W2-U)

* It is possible to individually purchase the communication cable and USB cable.

Communication cable JX-CTC-E

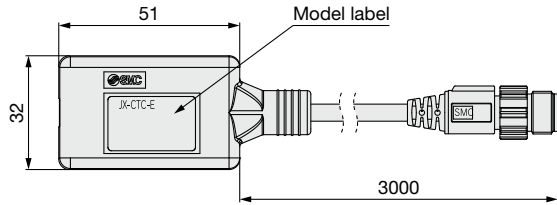

USB cable LEC-W2-U

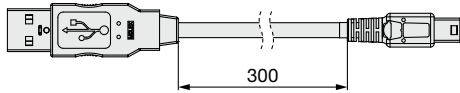

<Controller setting software/USB driver>

- Controller setting software
 - USB driver (For JXC-CT□-E)
- Download from SMC's website.

Hardware Requirements

OS	Windows®10 (64 bit), Windows®11 (64 bit)
Communication interface	USB 2.0 port
Display	1366 x 768 or more

* Windows®10 and Windows®11 are registered trademarks of Microsoft Corporation in the United States.

■ Power supply cable

JX-CD □ S - E - 1 - S

● Connector type

Symbol	Specifications
S	Straight
A	Right angled

● Cable length

	1	1.5 m
3	3 m	
5	5 m	
10	10 m	

● Connector type: Straight

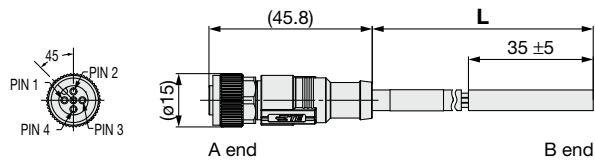

● Connector type: Right angled

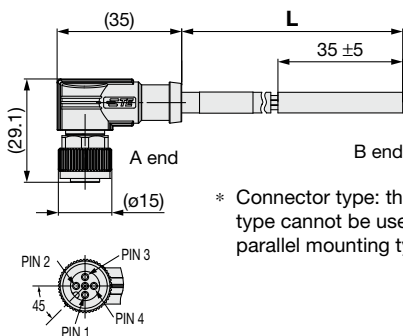

* Connector type: the right angled type cannot be used for the parallel mounting type.

■ Parallel I/O cable

JX-CI □ S - E - 1 - S

● Connector type

Symbol	Specifications
S	Straight
A	Right angled

● Cable length

	1	1.5 m
3	3 m	
5	5 m	
10	10 m	

● Connector type: Straight

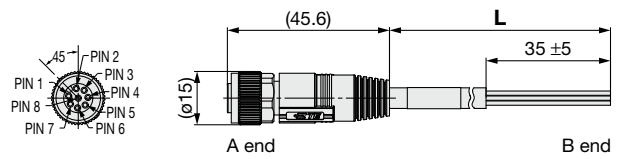

● Connector type: Right angled

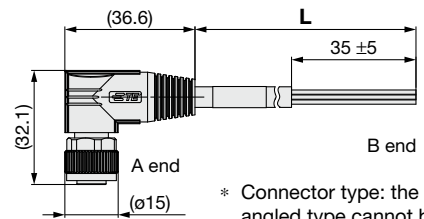

* Connector type: the right angled type cannot be used for the parallel mounting type.

Pin no.	Wire color	Signal
1	White	IN0
2	Brown	IN1
3	Green	RESET
4	Yellow	—
5	Gray	OUT0
6	Pink	OUT1
7	Blue	OUT2
8	Red	ALARM

Part no.	Weight [g]
JX-CIS-E-1-S	88
JX-CIS-E-3-S	164
JX-CIS-E-5-S	265
JX-CIS-E-10-S	517
JX-CIA-E-1-S	88
JX-CIA-E-3-S	164
JX-CIA-E-5-S	265
JX-CIA-E-10-S	517

Pin no.	Wire color	Signal
1	Brown	C24V
2	White	M24V
3	Blue	0V
4	Black	LK RLS

Part no.	Weight [g]
JX-CDS-E-1-S	68
JX-CDS-E-3-S	125
JX-CDS-E-5-S	200
JX-CDS-E-10-S	387
JX-CDA-E-1-S	68
JX-CDA-E-3-S	125
JX-CDA-E-5-S	200
JX-CDA-E-10-S	387

Model Selection

EQFS □ H Series

EQY □ H Series

EQYG □ H Series

Auto Switch

Electric Specifications

Wiring Examples

Options

CE/UKCA/UL-compliance List

* For CE, UKCA, and UL-compliant products, refer to the table below.

As of September 2024

■ Compliance List “○”: Compliant “×”: Not applicable “—”: No setting

Series	CE UK CA	UL	
		Compliance	Certification No. (File No.)
EQFS	○	○*1	E339743
EQY	○	○*1	E339743
EQYG	○	×	—

*1 Size 16 is not applicable.

Safety Instructions

These safety instructions are intended to prevent hazardous situations and/or equipment damage. These instructions indicate the level of potential hazard with the labels of “**Caution**,” “**Warning**” or “**Danger**.” They are all important notes for safety and must be followed in addition to International Standards (ISO/IEC)*1), and other safety regulations.

 **Danger :** **Danger** indicates a hazard with a high level of risk which, if not avoided, will result in death or serious injury.

 **Warning:** **Warning** indicates a hazard with a medium level of risk which, if not avoided, could result in death or serious injury.

 **Caution:** **Caution** indicates a hazard with a low level of risk which, if not avoided, could result in minor or moderate injury.

*1) ISO 4414: Pneumatic fluid power - General rules and safety requirements for systems and their components
ISO 4413: Hydraulic fluid power - General rules and safety requirements for systems and their components
IEC 60204-1: Safety of machinery - Electrical equipment of machines - Part 1: General requirements
ISO 10218-1: Robots and robotic devices - Safety requirements for industrial robots - Part 1: Robots etc.

Warning

1. The compatibility of the product is the responsibility of the person who designs the equipment or decides its specifications.

Since the product specified here is used under various operating conditions, its compatibility with specific equipment must be decided by the person who designs the equipment or decides its specifications based on necessary analysis and test results. The expected performance and safety assurance of the equipment will be the responsibility of the person who has determined its compatibility with the product. This person should also continuously review all specifications of the product referring to its latest catalog information, with a view to giving due consideration to any possibility of equipment failure when configuring the equipment.

2. Only personnel with appropriate training should operate machinery and equipment.

The product specified here may become unsafe if handled incorrectly. The assembly, operation and maintenance of machines or equipment including our products must be performed by an operator who is appropriately trained and experienced.

3. Do not service or attempt to remove product and machinery/equipment until safety is confirmed.

1. The inspection and maintenance of machinery/equipment should only be performed after measures to prevent falling or runaway of the driven objects have been confirmed.
2. When the product is to be removed, confirm that the safety measures as mentioned above are implemented and the power from any appropriate source is cut, and read and understand the specific product precautions of all relevant products carefully.
3. Before machinery/equipment is restarted, take measures to prevent unexpected operation and malfunction.

4. SMC products cannot be used beyond their specifications. They are not developed, designed, and manufactured to be used under the following conditions or environments. Use under such conditions or environments is not allowed.

1. Conditions and environments outside of the given specifications, or use outdoors or in a place exposed to direct sunlight.
2. Use for nuclear power, railways, aviation, space equipment, ships, vehicles, military application, equipment affecting human life, body, and property, combustion equipment, entertainment equipment, emergency shut-off circuits, press clutches, brake circuits, safety equipment, etc., and use for applications that do not conform to standard specifications such as catalogs and operation manuals.
3. Use for interlock circuits, except for use with double interlock such as installing a mechanical protection function in case of failure. Please periodically inspect the product to confirm that the product is operating properly.

Caution

SMC develops, designs, and manufactures products to be used for automatic control equipment, and provides them for peaceful use in manufacturing industries.

Use in non-manufacturing industries is not allowed.

Products SMC manufactures and sells cannot be used for the purpose of transactions or certification specified in the Measurement Act of each country. The new Measurement Act prohibits use of any unit other than SI units in Japan.

Limited warranty and Disclaimer/ Compliance Requirements

The product used is subject to the following “Limited warranty and Disclaimer” and “Compliance Requirements”.

Read and accept them before using the product.

Limited warranty and Disclaimer

1. The warranty period of the product is 1 year in service or 1.5 years after the product is delivered, whichever is first.*2)
Also, the product may have specified durability, running distance or replacement parts. Please consult your nearest sales branch.
2. For any failure or damage reported within the warranty period which is clearly our responsibility, a replacement product or necessary parts will be provided.
This limited warranty applies only to our product independently, and not to any other damage incurred due to the failure of the product.
3. Prior to using SMC products, please read and understand the warranty terms and disclaimers noted in the specified catalog for the particular products.

*2) **Vacuum pads are excluded from this 1 year warranty.**

A vacuum pad is a consumable part, so it is warranted for a year after it is delivered.

Also, even within the warranty period, the wear of a product due to the use of the vacuum pad or failure due to the deterioration of rubber material are not allowed by the limited warranty.

Compliance Requirements

1. The use of SMC products with production equipment for the manufacture of weapons of mass destruction (WMD) or any other weapon is strictly prohibited.
2. The exports of SMC products or technology from one country to another are governed by the relevant security laws and regulations of the countries involved in the transaction. Prior to the shipment of a SMC product to another country, assure that all local rules governing that export are known and followed.

Revision History

Edition B * EQFS16H and EQY16H have been added.

* Errors in text have been corrected.

* The number of pages has been increased from 60 to 68.

Edition C * A guide rod type (EQYG□H series) has been added.

* The number of pages has been increased from 68 to 84.

Safety Instructions

Be sure to read the “Handling Precautions for SMC Products” (M-E03-3) and “Operation Manual” before use.

SMC Corporation