

Ionizer / Bar Type

New
CE UK
CA

High speed static
neutralization

Fastest time **0.1 s***1

RoHS

Space saving

Height **70 mm** x Width **28 mm**

- Supports the IO-Link communication protocol
- Low maintenance cartridge

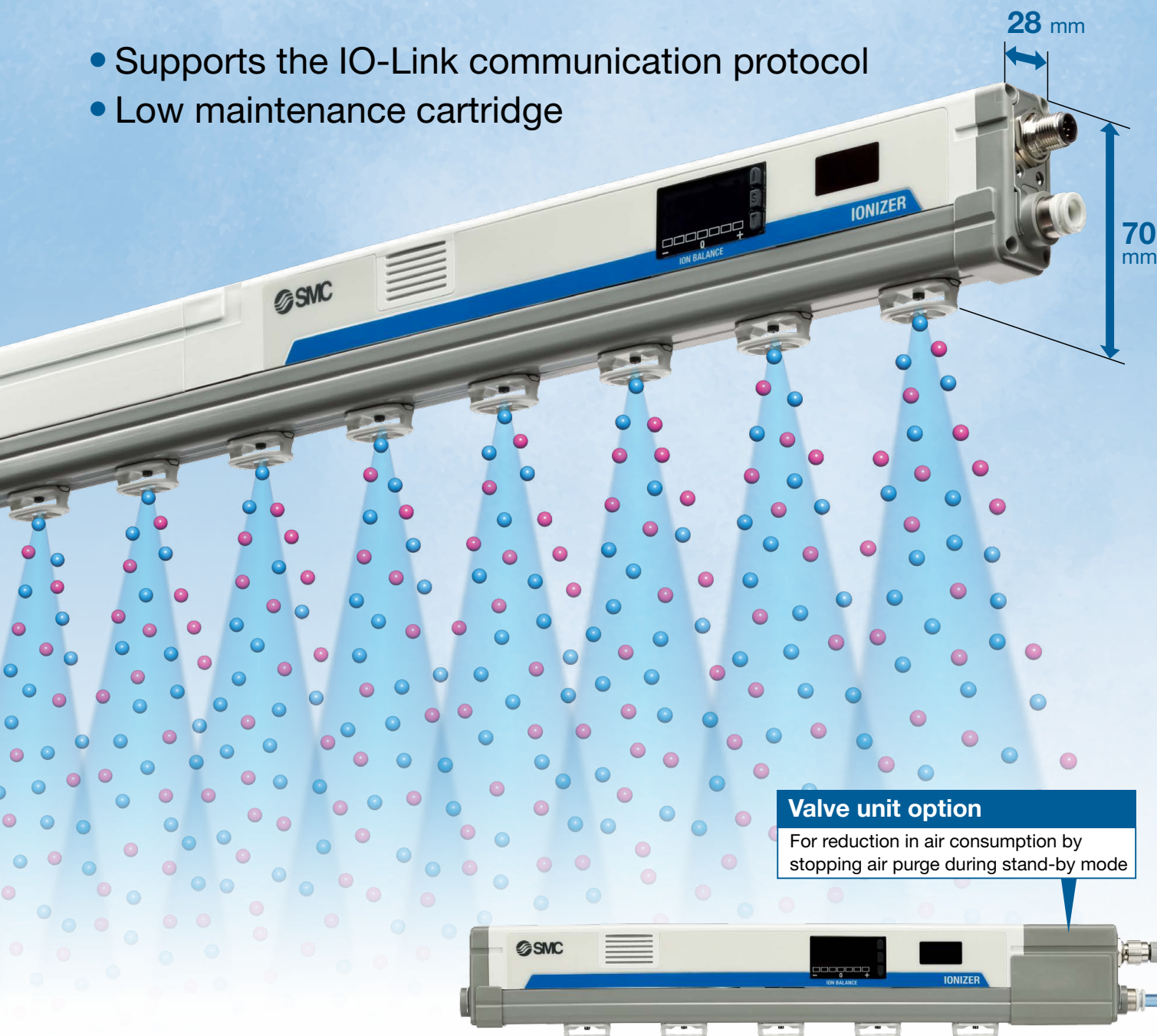

*1 Conditions: Discharge time from 1000 V to 100 V
Object to be neutralized: Charged plate (Dimensions: 150 mm x 150 mm, Capacitance: 20 pF)
Installation distance: 100 mm (Tungsten emitter, Air purge: 0.3 MPa)

IZS51 Series

SMC
CAT.ES100-172A

Compact and flat body

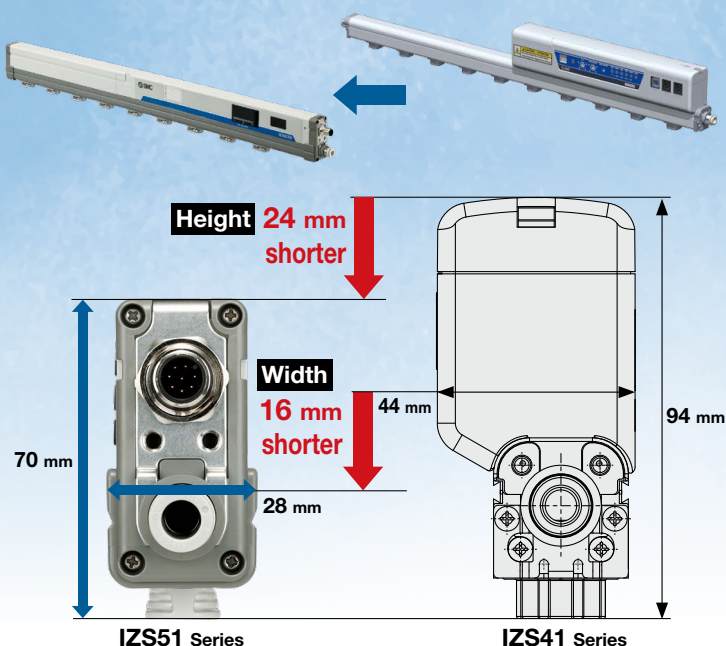

Compact body with piping on one side

Can be mounted in narrow spaces

Installation example

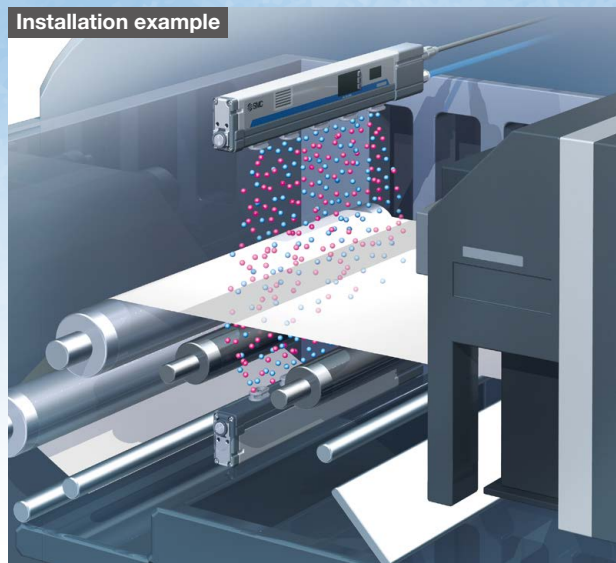

Valve unit option

- A 2-port valve is integrated into the ionizer, achieving space saving and reduced wiring.
- Air purge can be stopped using a stop signal for the ion generation.
- Zero flow consumption during stand-by mode

Zero flow consumption during stand-by mode
Stand by using a 25% electrical current compared with eliminating static electricity

Stand-by mode



During static neutralization



Integrated

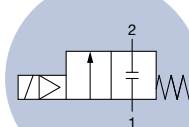

2-port valve

With auto balance function

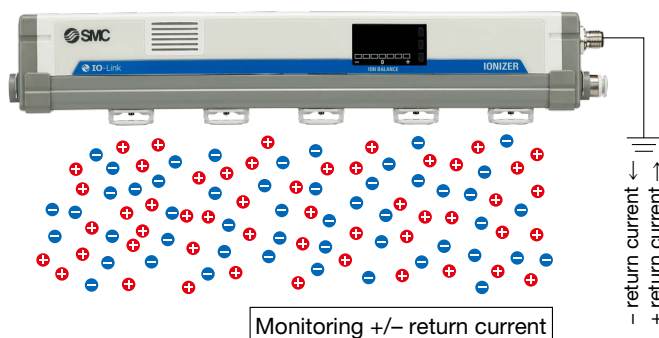

The offset voltage (ion balance) in the static neutralization area is controlled so that the voltage is maintained at a constant value by monitoring the ions emitted from the ionizer using the ground line.

Effect of auto balance sensor (Image)

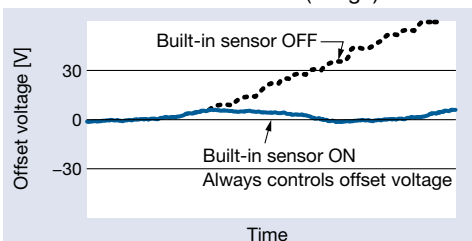

Piping on one side possible

- The electrical wiring and air piping are positioned in the end of the product.
- Maintains enough air purge performance even with piping on one side.

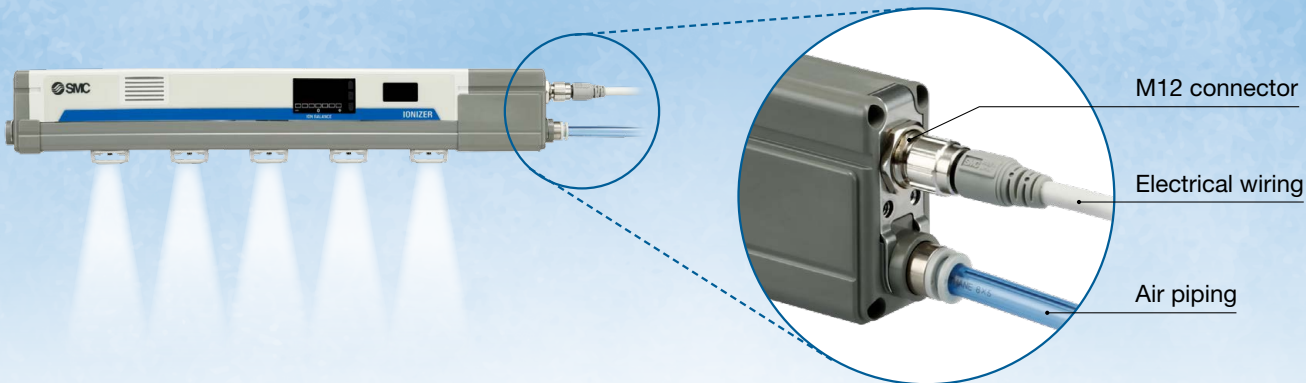

Low maintenance cartridge

- Concentrating the air (for reducing emitter contamination) around the emitter and the assisting air (for ion transfer)
- Reduces dirt on the emitter, compared with the existing model

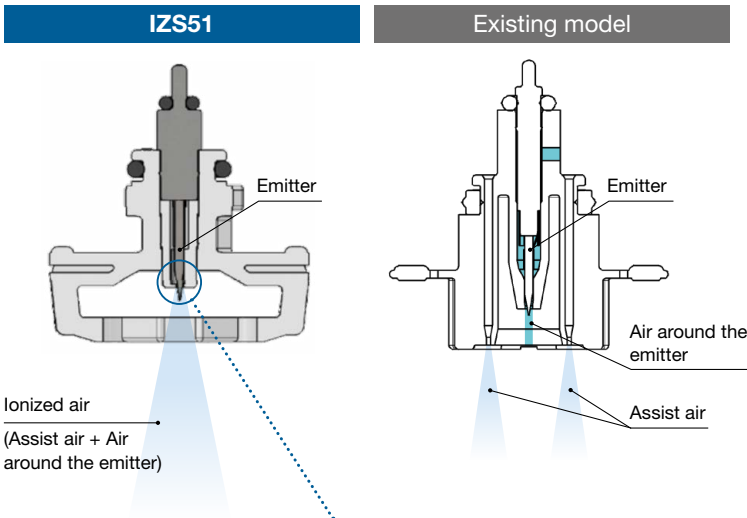

- **Low maintenance**
Reduces emitter contamination by increasing the air flow around the emitter, compared with previous models.
- **High speed static neutralization**
The air flow around the emitter tip has been optimized to improve ion transfer efficiency.

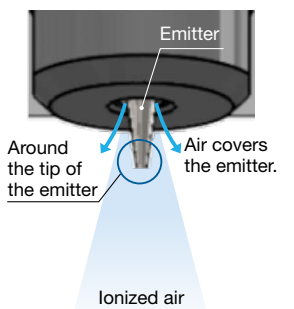

Reduced discharge time (-14%)

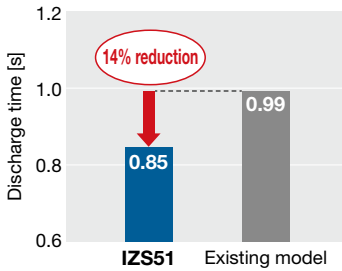

Existing model (High speed static neutralization cartridge)
 IZS51 (High flow cartridge)
 · Number of cartridges: 10 pcs.
 · Flow rate per cartridge 11.1 L/min (ANR)
 · Comparison at an installation distance of 600 mm

Cartridge variations

Choice of a cartridge type suitable for an application such as a high-speed static neutralization with a high flow or static neutralization with a low flow

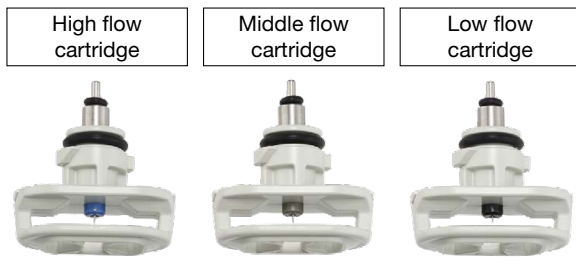

Required consumed flow until the static elimination time reaches 1 second by each installation distance.
 Conditions: IZS51-1100□ (Number of cartridges: 18 pcs.), Discharge time 1 s

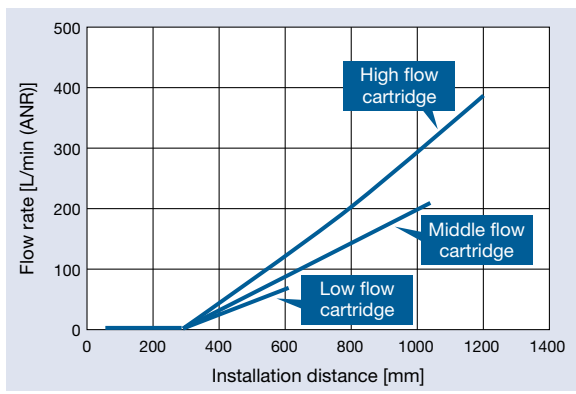

Emitter material type



Improved maintainability

- Clean all the emitters with a dedicated cleaning kit.

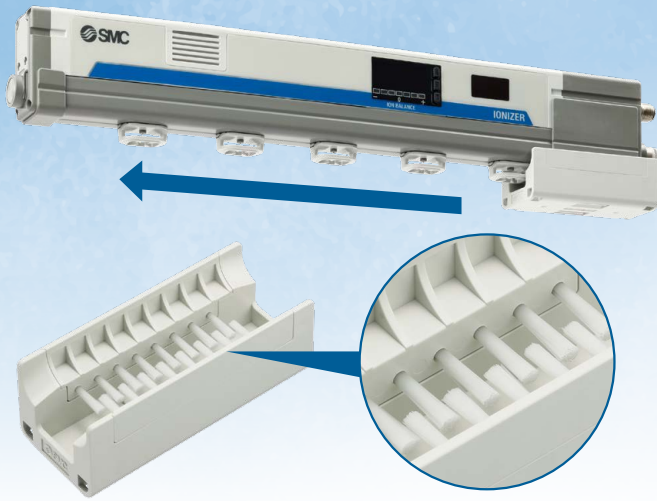

8 brushes x 2

Maintenance detection function

- Constantly monitors for dirt on an emitter. Choice of 3 detection levels



Operation status can be checked at a glance.

Normal operation

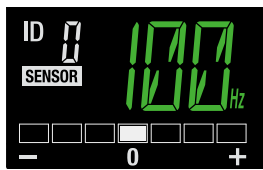

Frequency display
Built-in sensor ON/OFF display

When an alarm is output

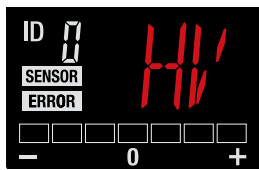

CPU failure
Power supply failure
Incorrect high voltage
Output signal overcurrent

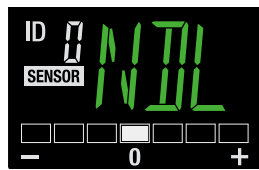

Maintenance warning

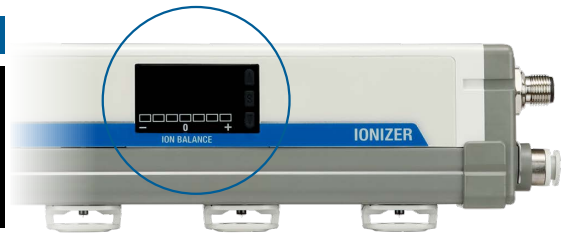

Output signals check function

Capable of checking for the connection to a PLC or an IO-Link master or status errors in the upper system equipment

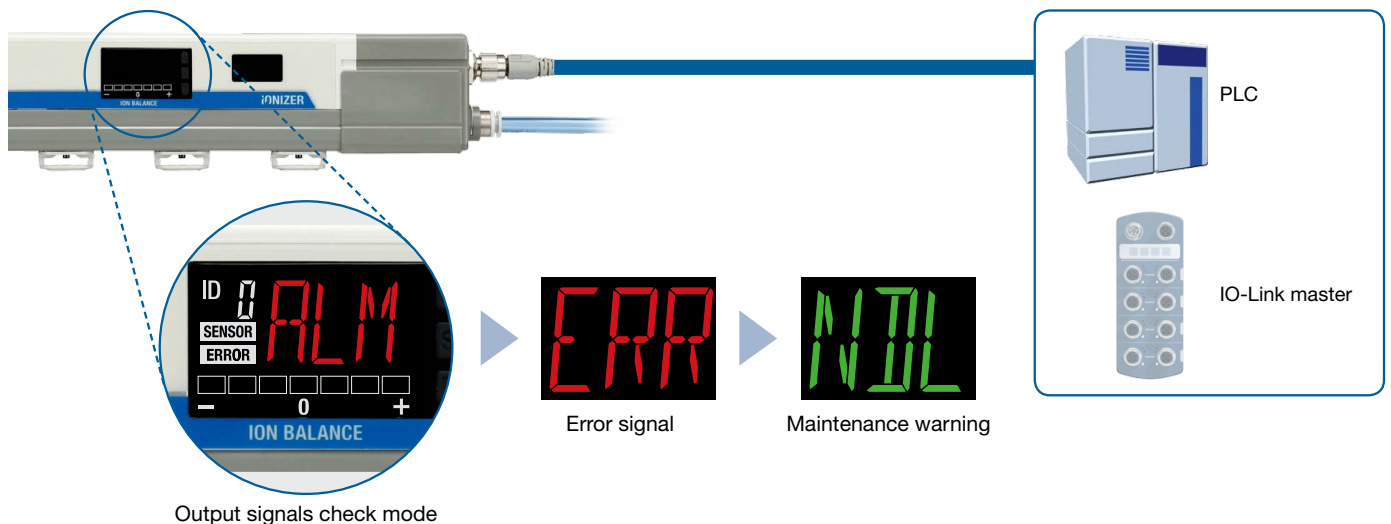

2 types of brackets are available.

When an adjustable mounting angle is required / Bracket 1



When space reduction is required / Bracket 2



The ionizers can be set with a remote controller.

- The ionizer can be adjusted and set remotely.
 - Up to 16 ionizers can be identified by address setting.
 - Frequency setting
 - Offset voltage adjustment
 - The built-in sensor can be switched ON and OFF.
 - Maintenance detection level selection: 3 levels
 - Switching ON/OFF for the simultaneous operations of the ion generation and air supply stop*1
- *1 Only when the valve unit is installed



Safety function

Drop prevention cover: For increased cartridge drop prevention

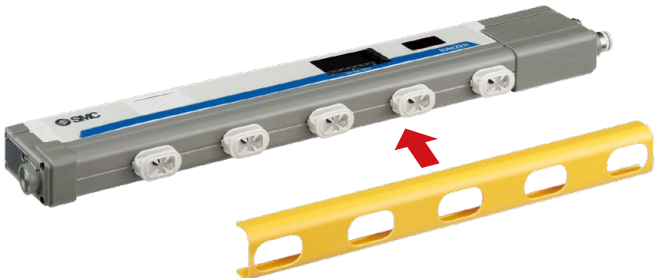

Supports the IO-Link communication protocol

Visualization of operation and equipment status/Remote monitoring and control by communication

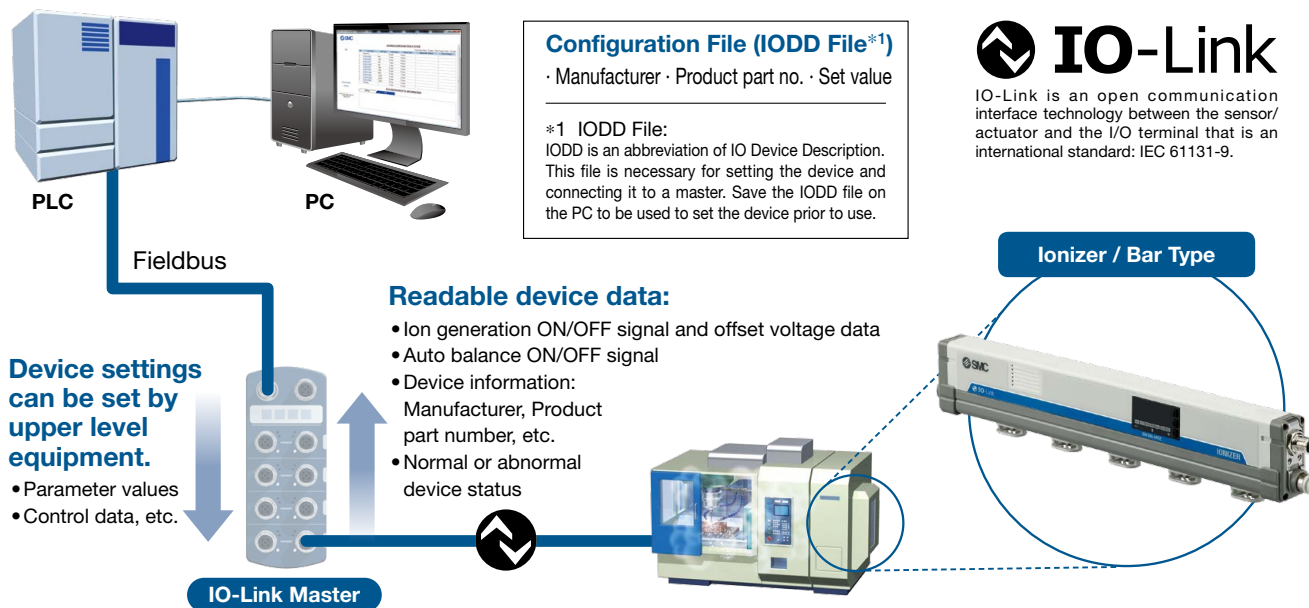

Automatic setting function [Data storage function]

When replacing the controller with another of the same type (the same device ID), the parameters (set values) stored in the IO-Link master are automatically copied (set) to the new controller.

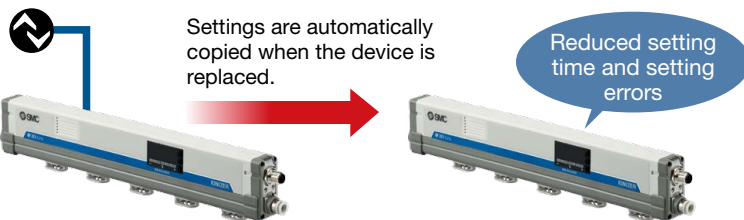

Process Data

PD_IN

Bit offset	23	22	21	20	19	18	17	16
Item	Ion generation	Air supply	Output signals check mode	Reserved			Ion balance	

Bit offset	15	14	13	12	11	10	9	8
Item	Ion balance							

Bit offset	7	6	5	4	3	2	1	0
Item	Error diagnosis	CPU failure	IOL power supply failure	CTL power supply failure	Incorrect high voltage	Maintenance notification	Reserved	

It is possible to monitor the ion balance with the cyclic (periodic) data.

It is possible to find problems with the equipment in detail with the cyclic (periodic) data.

PD_OUT

Bit offset	15	14	13	12	11	10	9	8
Item	Process data output valid	Ion generation	Air supply	Reserved			Offset voltage adjustment	

Bit offset	7	6	5	4	3	2	1	0
Item	Offset voltage adjustment							

It is possible to adjust the offset voltage with the cyclic (periodic) data.

Application examples

For the static neutralization of resin frames

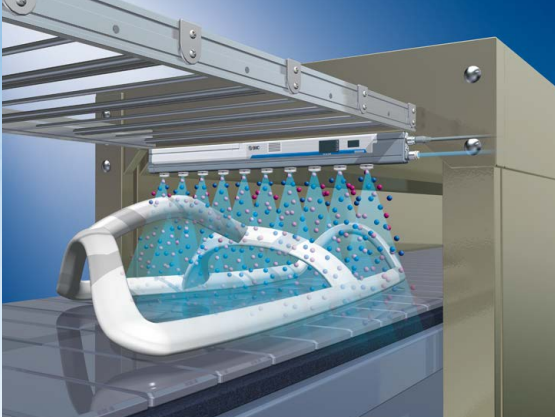

For the static neutralization of PET bottles

- Prevents bottles from falling over on conveyor belts
- Prevents the adhesion of dust

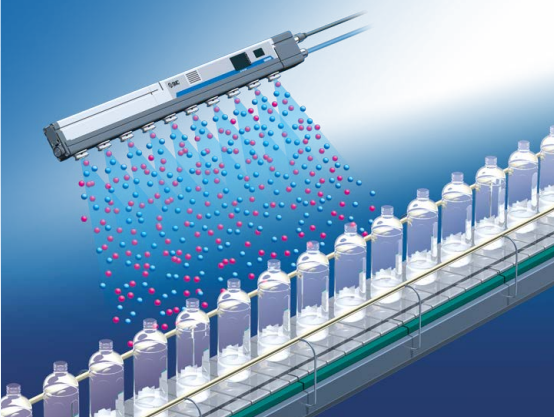

For the static neutralization of film-molded goods

- Prevents goods from adhering to the conveyer
- Prevents the dispersion of finished goods

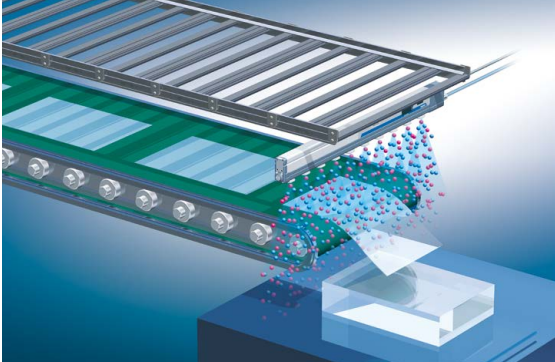

For the static neutralization of parts feeders

- Prevents the clogging of parts feeders

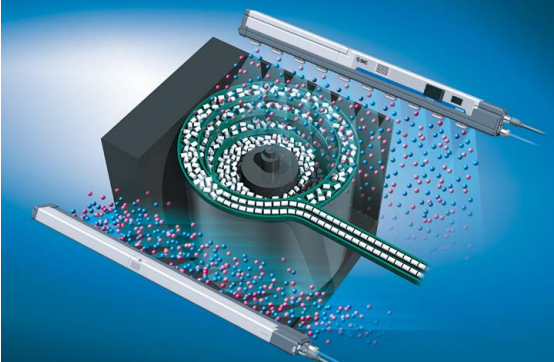

For the static neutralization of packing films

- Prevents the filled substances from adhering to packing films
- Reduces packing mistakes

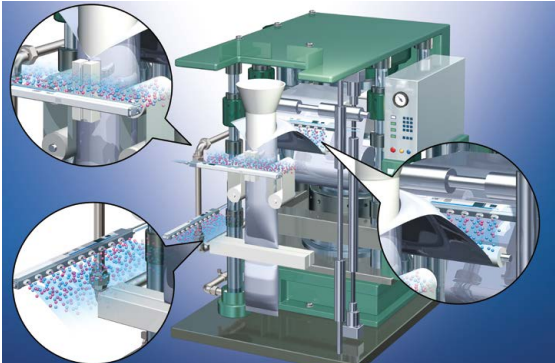

For the static neutralization during wafer transfer

- Prevents breakage due to discharge between wafers and hands

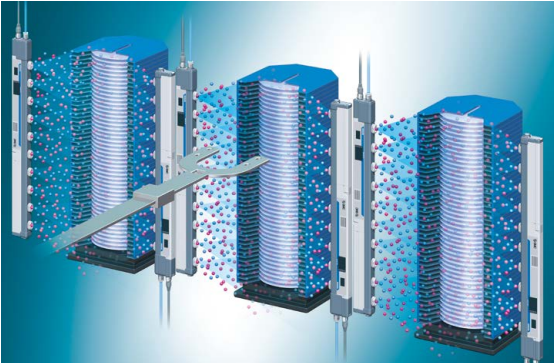

For the static neutralization of glass substrates

- Prevents the breakage of glass substrates by the static electricity generated when the substrate is lifted from the surface plate

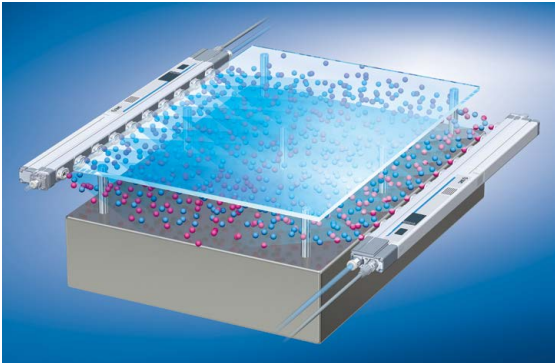

For the static neutralization of lenses

- Removes dust from lenses
- Prevents the adhesion of dust

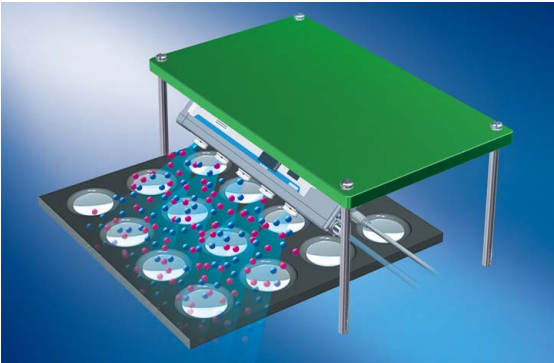

CONTENTS

Ionizer / Bar Type *IZS51 Series*

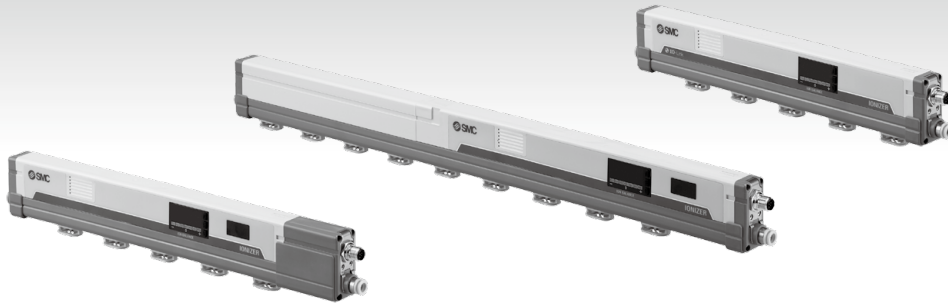

Technical Data: Static Neutralization Characteristics

① Installation Distance and Discharge Time	p. 8
② Static Neutralization Range	p. 8
③ Pressure — Flow Rate Characteristics	p. 10
How to Order	p. 11
Made to Order	p. 13
Specifications.....	p. 14
Accessories / Accessories Sold Separately (for Individual Parts) ...	p. 15
Wiring Circuit	p. 17
Dimensions	p. 19
Safety Instructions	Back cover

⚠ IZS51 Series / Specific Product Precautions

Be sure to read this before handling the products. For the safety instructions, refer to the “Handling Precautions for SMC Products” and the “Operation Manual” found on the SMC website.

IZS51 Series

Technical Data

* Static neutralization characteristics are based on data using a charged plate (Dimensions: 150 mm x 150 mm, Capacitance: 20 pF) as defined in the U.S. ANSI standards (ANSI/ESD STM3.1-2015). Use this data only as a guideline for model selection because the values vary depending on the material and/or size of the subject.

Static Neutralization Characteristics

① Installation Distance and Discharge Time (Discharge Time from 1000 V to 100 V)

For cartridges without air purge

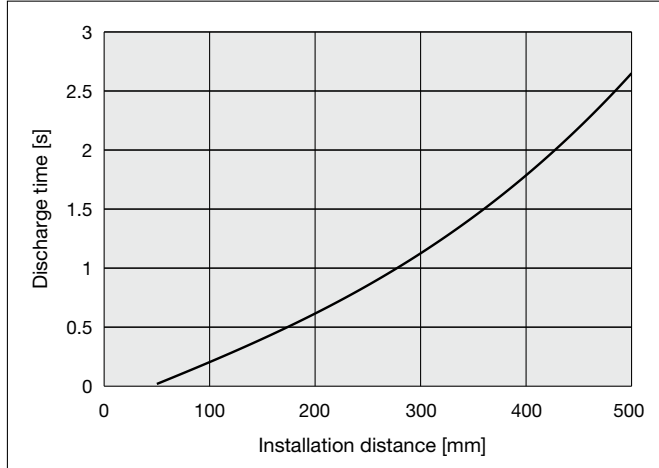

Low flow cartridge

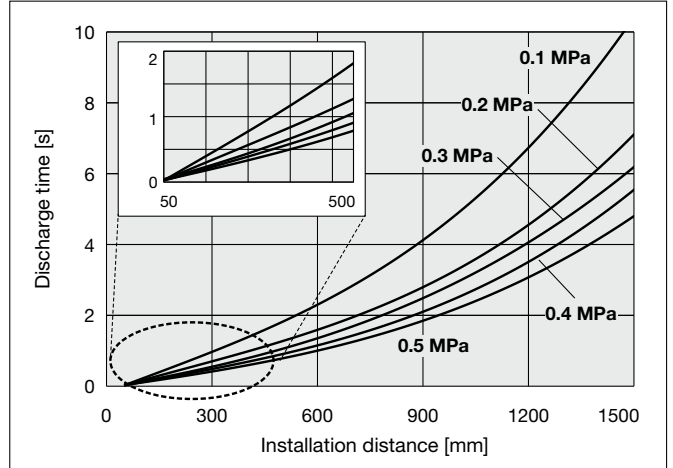

Middle flow cartridge

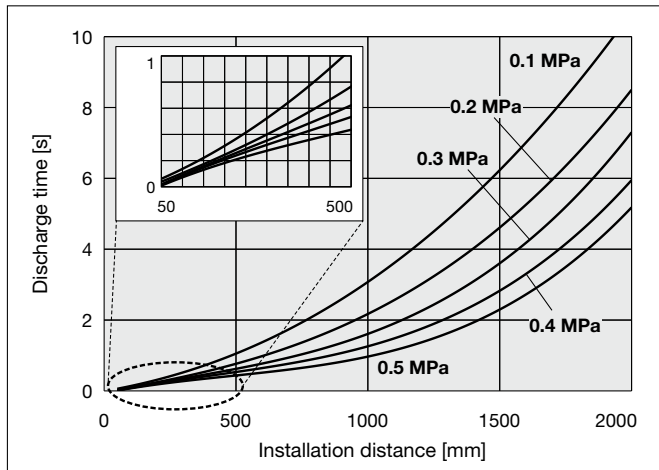

High flow cartridge

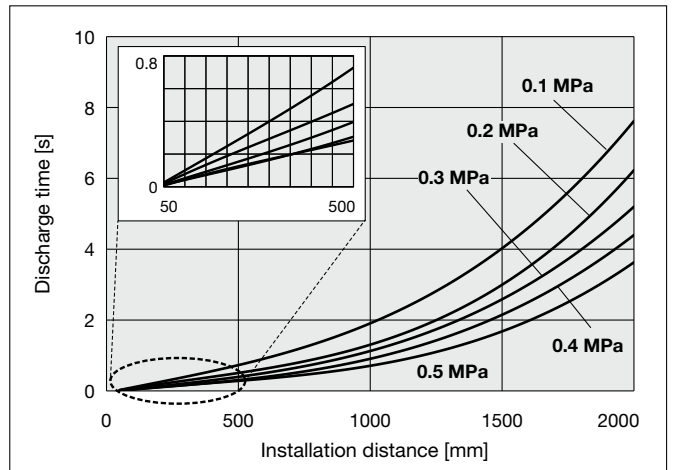

② Static Neutralization Range (Discharge Time from 1000 V to 100 V)

1) For cartridges without air purge

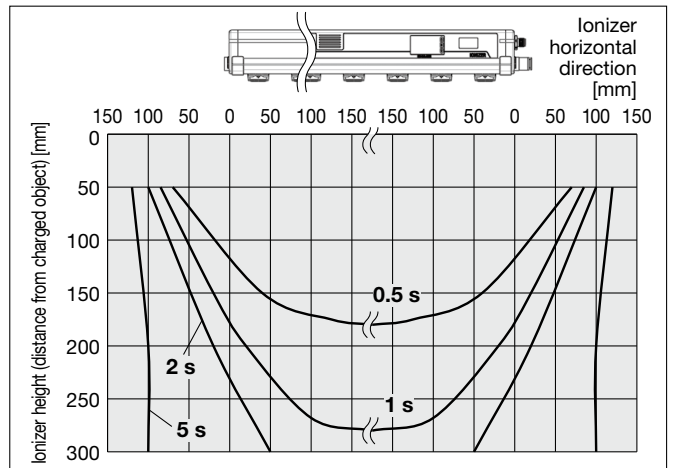
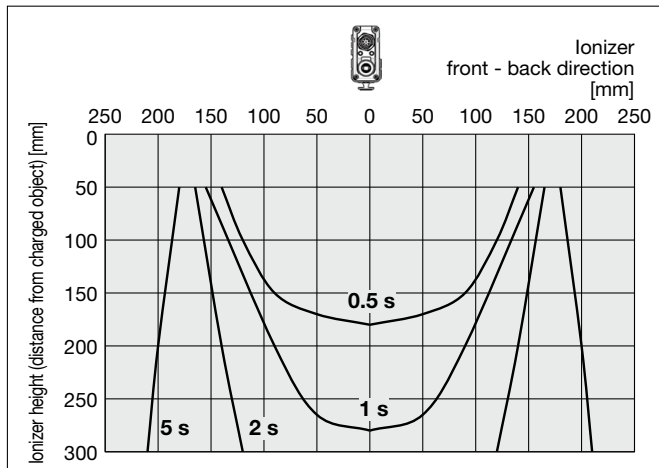

* Static neutralization characteristics are based on data using a charged plate (Dimensions: 150 mm x 150 mm, Capacitance: 20 pF) as defined in the U.S. ANSI standards (ANSI/ESD STM3.1-2015). Use this data only as a guideline for model selection because the values vary depending on the material and/or size of the subject.

Static Neutralization Characteristics

② Static Neutralization Range (Discharge Time from 1000 V to 100 V)

2) Low flow cartridge (Supply pressure: 0.3 MPa)

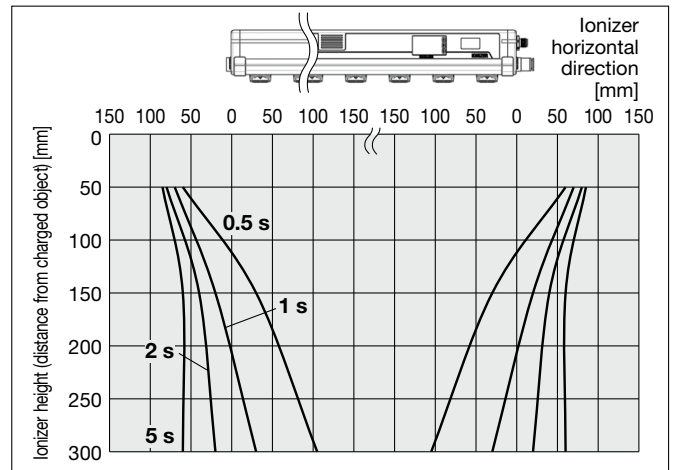
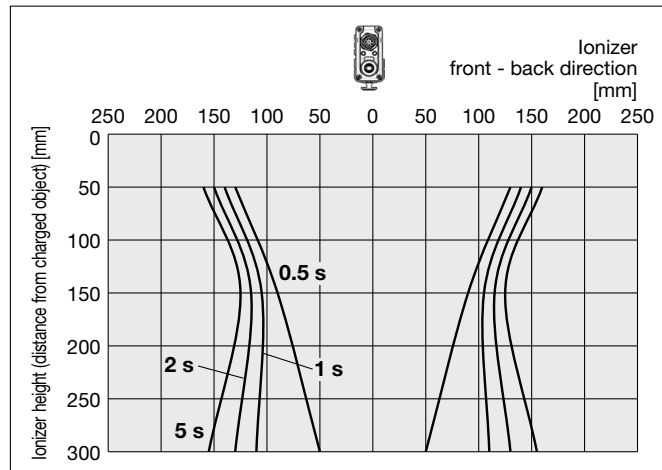

3) Middle flow cartridge (Supply pressure: 0.3 MPa)

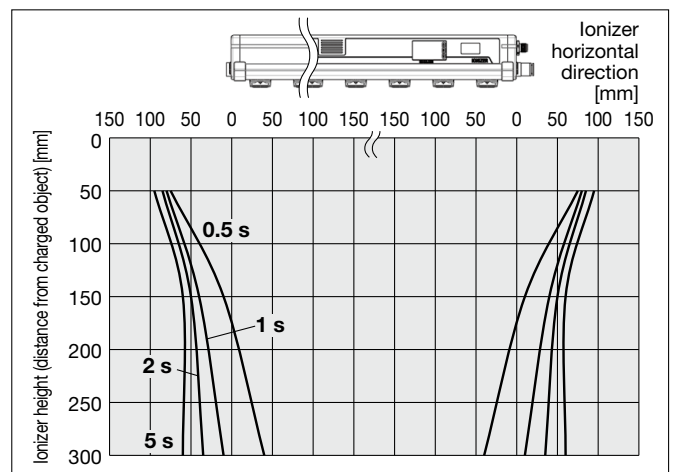
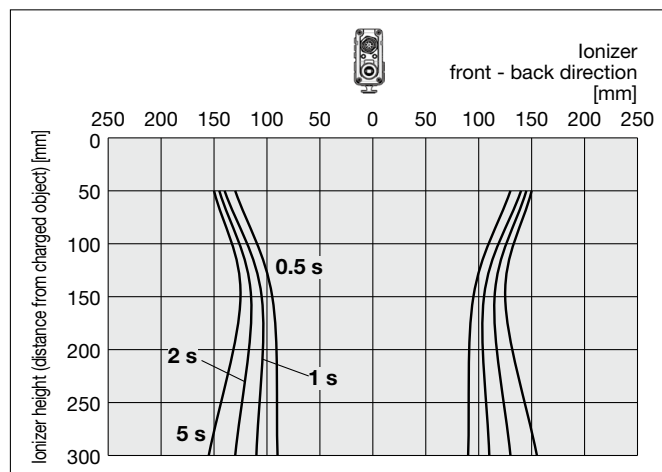

4) High flow cartridge (Supply pressure: 0.3 MPa)

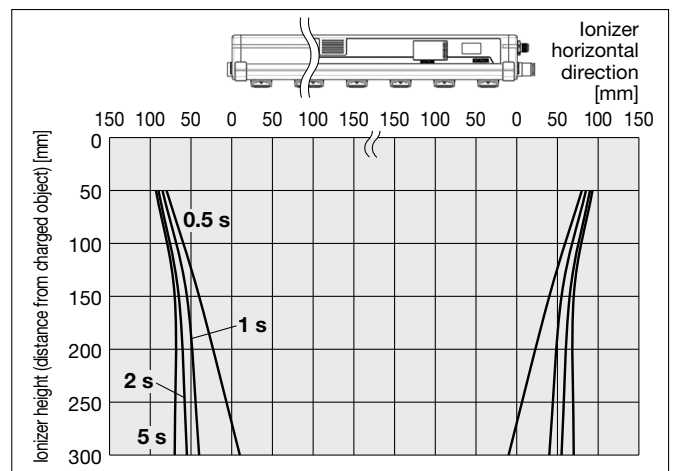
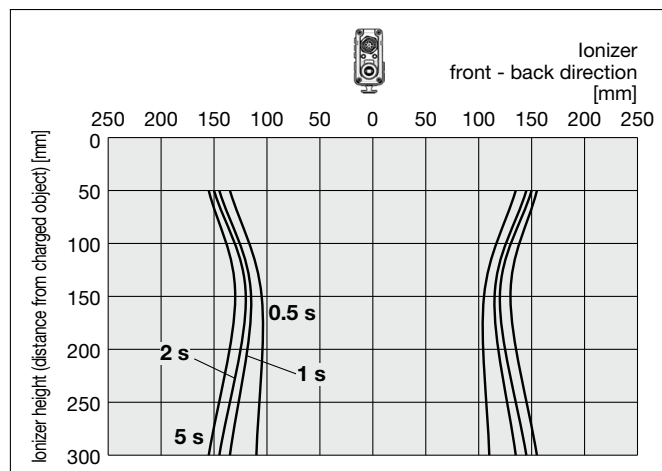

* Static neutralization characteristics are based on data using a charged plate (Dimensions: 150 mm x 150 mm, Capacitance: 20 pF) as defined in the U.S. ANSI standards (ANSI/ESD STM3.1-2015). Use this data only as a guideline for model selection because the values vary depending on the material and/or size of the subject.

Static Neutralization Characteristics

③ Pressure – Flow Rate Characteristics

Without the Valve Unit

Low flow cartridge

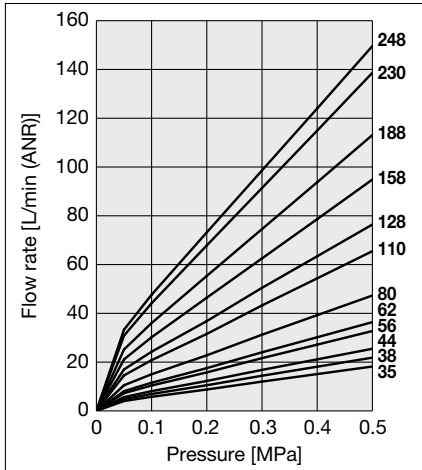

Middle flow cartridge

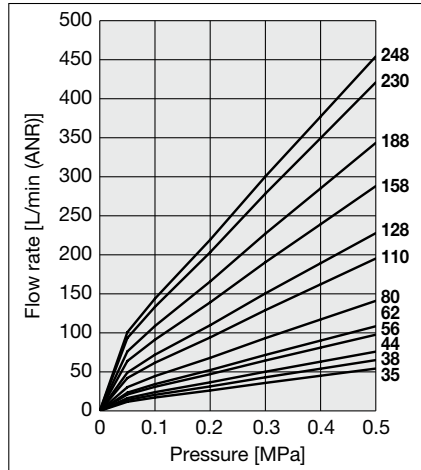

High flow cartridge

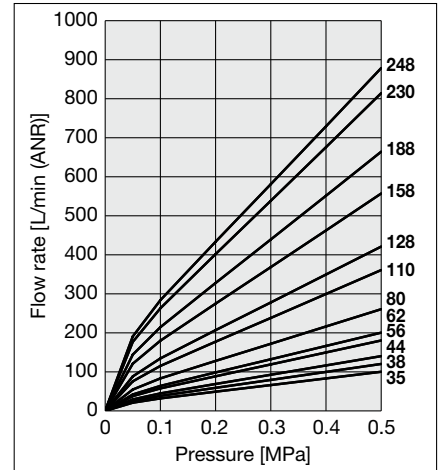

With the Valve Unit

Low flow cartridge

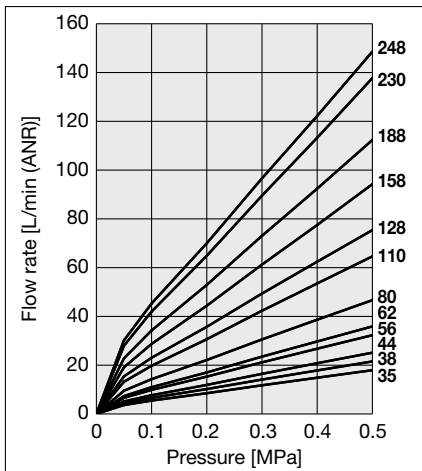

Middle flow cartridge

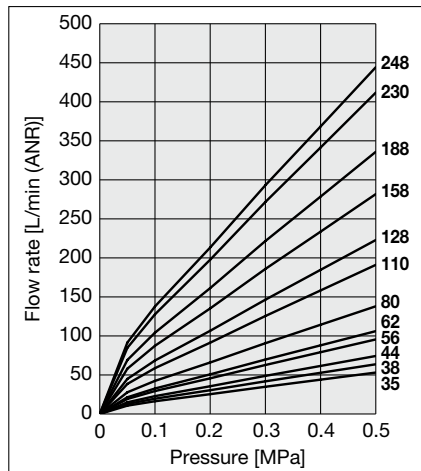

High flow cartridge

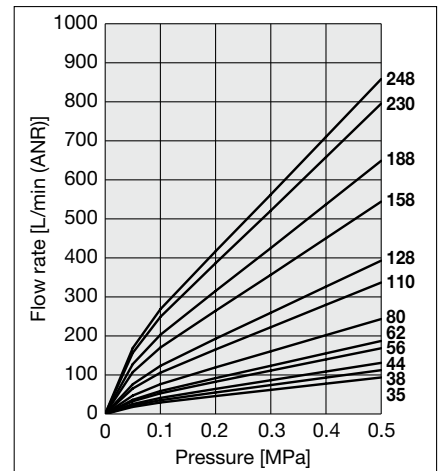

How to measure

- a) Piping on one side.....Connecting tube O.D. $\phi 10$ x I.D. $\phi 6.5$
Bar length symbol: 35, 38, 44, 56, 62, 80, 110, 128

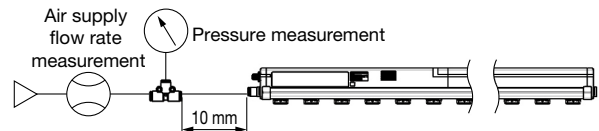

- b) Piping on both sides.....Connecting tube O.D. $\phi 10$ x I.D. $\phi 6.5$
Bar length symbol: 158, 188, 230, 248

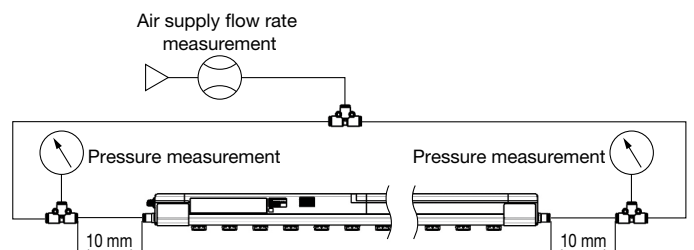

Ionizer / Bar Type

IZS51 Series

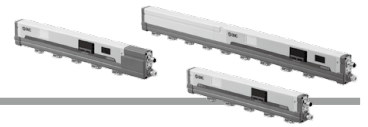

How to Order

Transistor input/output

IZS51 - 158 T N - V 4 - 3 - [] [] - X10

IO-Link

IZS51 - 158 T L - V 4 - 3 E 3 - [] [] - X10

Bar type •

① ② ③ ④ ⑤ ⑥ ⑦ ⑧ ⑨ ⑩ ⑪

① Bar length

Symbol	Bar length [mm]	Symbol	Bar length [mm]
35	350	110	1100
38	380	128	1280
44	440	158	1580
56	560	188	1880
62	620	230	2300
80	800	248	2480

② Emitter cartridge type/Emitter material

Symbol	Type	Material
T	High flow cartridge	Tungsten
C		Silicon
J	Middle flow cartridge	Tungsten
K		Silicon
V	Low flow cartridge	Tungsten
S		Silicon

③ Input/Output

Symbol	Type
N	NPN input/output
P	PNP input/output

④ Piping port

Symbol	Type
Nil	Piping on both sides
D	Piping on one side*1
V	With the valve unit*1, *2

*1 Air supply from M12 connector side (Another side is plugged.)

*2 Valve units are mounted on both sides of the bar. When the emitter cartridge type is a high flow cartridge (symbol: T or C) and the bar length is selected 1580, 1880, 2300 or 2480.

⑤ One-touch fitting

Symbol	Metric size	Symbol	Inch size
4	ø4 Straight	5	ø3/16" Straight
6	ø6 Straight	7	ø1/4" Straight
8	ø8 Straight	9	ø5/16" Straight
A	ø10 Straight	B	ø3/8" Straight

* The selected one-touch fittings vary depending on the ② emitter cartridge type and ④ the piping port. Select the product, referring to the recommended port size on the following page.

⑥ Power supply cable (For NPN/PNP type/IO-Link type)

Symbol	Type
N	None
3	3 m
5	5 m
Z	10 m
S	0.5 m
1	1 m
3	3 m

For transistor input/output (NPN/ PNP) type

For IO-Link type

⑦ Communication cable (For IO-Link type)

Symbol	Type
N	None
E	0.5 m
G	1 m
J	3 m

⑧ Relay cable (For IO-Link type)

Symbol	Type
N	None
3	3 m*1
5	5 m*1
Z	10 m*1

*1 Included T-connector (1 pc.)

⑨ Bracket

Symbol	Type
Nil	None
B	With bracket 1
W	With bracket 2

* The number of intermediate brackets depends on the bar length. (Refer to the table below.)

Number of brackets

Bar length symbol	End bracket	Intermediate bracket
35 to 62	With 2 pcs.	None
80 to 158		With 1 pc.
188 to 230		With 2 pcs.
248		With 3 pcs.

⑩ Remote controller

Symbol	Type
Nil	None
R	Included

⑪ Made to order

Symbol	Type
-X10	Non-standard bar length
-X14	Model with drop prevention cover

Recommended Piping Port Size

■ Without the valve unit IZS51-□□□-□

④ Select one-touch fittings from the table below when the piping port is selected from either piping on both sides (Nil) or piping on one side (D).

IZS51-□T(C)□ High flow cartridge

Symbol	Applicable tube O.D.	350	380	440	560	620	800	1100	1280	1580	1880	2300	2480
4	ø4	●	●	●	—	—	—	—	—	—	—	—	—
6	ø6	○	○	○	○	●	●	●	—	—	—	—	—
8	ø8	○	○	○	○	○	○	●	●	●	●	—	—
A	ø10	○	○	○	○	○	○	○	○	○	●	●	●
5	ø3/16"	○	○	●	●	●	—	—	—	—	—	—	—
7	ø1/4"	○	○	○	○	○	●	●	●	—	—	—	—
9	ø5/16"	○	○	○	○	○	○	●	●	●	●	—	—
B	ø3/8"	○	○	○	○	○	○	○	○	○	●	●	●

○: Can be selected for either piping on both sides or piping on one side ●: Can be selected only for piping on both sides —: The bar length in use cannot select the port size.

IZS51-□J(K)□ Middle flow cartridge

Symbol	Applicable tube O.D.	350	380	440	560	620	800	1100	1280	1580	1880	2300	2480
4	ø4	○	○	○	●	●	●	—	—	—	—	—	—
6	ø6	○	○	○	○	○	○	○	●	●	●	●	—
8	ø8	○	○	○	○	○	○	○	○	○	○	●	●
A	ø10	○	○	○	○	○	○	○	○	○	○	○	○
5	ø3/16"	○	○	○	○	○	●	●	●	—	—	—	—
7	ø1/4"	○	○	○	○	○	○	○	○	●	●	●	●
9	ø5/16"	○	○	○	○	○	○	○	○	○	○	●	●
B	ø3/8"	○	○	○	○	○	○	○	○	○	○	○	○

○: Can be selected for either piping on both sides or piping on one side ●: Can be selected only for piping on both sides —: The bar length in use cannot select the port size.

IZS51-□V(S)□ Low flow cartridge

Symbol	Applicable tube O.D.	350	380	440	560	620	800	1100	1280	1580	1880	2300	2480
4	ø4	○	○	○	○	○	○	○	○	○	●	●	●
6	ø6	○	○	○	○	○	○	○	○	○	○	○	○
8	ø8	○	○	○	○	○	○	○	○	○	○	○	○
A	ø10	○	○	○	○	○	○	○	○	○	○	○	○
5	ø3/16"	○	○	○	○	○	○	○	○	○	○	○	○
7	ø1/4"	○	○	○	○	○	○	○	○	○	○	○	○
9	ø5/16"	○	○	○	○	○	○	○	○	○	○	○	○
B	ø3/8"	○	○	○	○	○	○	○	○	○	○	○	○

○: Can be selected for either piping on both sides or piping on one side ●: Can be selected only for piping on both sides

■ With the valve unit: IZS51-□□□-V

④ Select one-touch fittings from the table below when the piping port is selected as the valve unit option (V).

IZS51-□T(C)□-V High flow cartridge

Symbol	Applicable tube O.D.	350	380	440	560	620	800	1100	1280	1580	1880	2300	2480
4	ø4	—	—	—	—	—	—	—	—	—	—	—	—
6	ø6	□	□	□	□	—	—	—	—	—	—	—	—
8	ø8	□	□	□	□	□	□	—	—	—	—	—	—
A	ø10	□	□	□	□	□	□	□	□	■	■	■	■
5	ø3/16"	□	□	—	—	—	—	—	—	—	—	—	—
7	ø1/4"	□	□	□	□	□	—	—	—	—	—	—	—
9	ø5/16"	□	□	□	□	□	□	—	—	—	—	—	—
B	ø3/8"	□	□	□	□	□	□	□	□	■	■	■	■

□: The valve unit is attached to the M12 connector side of the product. The piping port on the opposite side is plugged.

■: The valve units are attached to both sides of the body. Supply air from the piping ports on both sides. —: The bar length in use cannot select the port size.

IZS51-□J(K)□-V Middle flow cartridge

Symbol	Applicable tube O.D.	350	380	440	560	620	800	1100	1280	1580	1880	2300	2480
4	ø4	□	□	□	—	—	—	—	—	—	—	—	—
6	ø6	□	□	□	□	□	□	□	—	—	—	—	—
8	ø8	□	□	□	□	□	□	□	□	□	□	□	□
A	ø10	□	□	□	□	□	□	□	□	□	□	□	□
5	ø3/16"	□	□	□	□	□	—	—	—	—	—	—	—
7	ø1/4"	□	□	□	□	□	□	□	□	—	—	—	—
9	ø5/16"	□	□	□	□	□	□	□	□	□	□	□	□
B	ø3/8"	□	□	□	□	□	□	□	□	□	□	□	□

□: The valve unit is attached to the M12 connector side of the product. The piping port on the opposite side is plugged. —: The bar length in use cannot select the port size.

IZS51-□V(S)□-V Low flow cartridge

Symbol	Applicable tube O.D.	350	380	440	560	620	800	1100	1280	1580	1880	2300	2480
4	ø4	□	□	□	□	□	□	□	□	□	—	—	—
6	ø6	□	□	□	□	□	□	□	□	□	□	□	□
8	ø8	□	□	□	□	□	□	□	□	□	□	□	□
A	ø10	□	□	□	□	□	□	□	□	□	□	□	□
5	ø3/16"	□	□	□	□	□	□	□	□	□	□	□	□
7	ø1/4"	□	□	□	□	□	□	□	□	□	□	□	□
9	ø5/16"	□	□	□	□	□	□	□	□	□	□	□	□
B	ø3/8"	□	□	□	□	□	□	□	□	□	□	□	□

□: The valve unit is attached to the M12 connector side of the product. The piping port on the opposite side is plugged. —: The bar length in use cannot select the port size.

IZS51 Series

Made to Order

Symbol	Description	Specifications
-X10	Non-standard bar length	Manufacturable bar length [mm]: 440 + 60 x N (n: Integer from 1 to 34) (For n = 2, 3, 6, 11, 14, 19, 24, 31, and 34, use a standard model.)

Transistor input/output IZS51 - - - - - **X10**

IO-Link IZS51 - **L** - - - - **X10**

Standard model number → p. 11

Bar length

Symbol	Length [mm]	Symbol	Length [mm]	Symbol	Length [mm]	Symbol	Length [mm]	Symbol	Length [mm]
50	500	98	980	140	1400	176	1760	212	2120
68	680	104	1040	146	1460	182	1820	218	2180
74	740	116	1160	152	1520	194	1940	224	2240
86	860	122	1220	164	1640	200	2000	236	2360
92	920	134	1340	170	1700	206	2060	242	2420

Symbol	Description	Specifications
-X14	Model with drop prevention cover	The main unit is shipped fitted with a drop prevention cover available as an option.

Transistor input/output IZS51 - - - - - **X14**

IO-Link IZS51 - **L** - - - - **X14**

Standard model number → p. 11

Compliant with non-standard bar lengths. For the non-standard bar lengths, refer to the table for -X10 bar lengths.



Specifications

Ionizer

Ionizer model	IZS51-□□N (NPN)	IZS51-□□P (PNP)	IZS51-□□L (IO-Link)
Ion generation method	Corona discharge type		
Method of applying voltage	AC, DC*1		
Applied voltage*2	±7000 V		
Offset voltage*3	Within ±30 V		
Air purge	Fluid	Air (Clean, dry air)	
	Operating pressure	0.5 MPa or less	
	Proof pressure	0.7 MPa	
	Connecting tube size	Metric size: ø4, ø6, ø8, ø10 Inch size: ø3/16", ø1/4", ø5/16", ø3/8"	
Power supply voltage	24 VDC ±10%		
Current consumption	700 mA or less		
Input signal*4	Connected to DC (-) Voltage range: 5 VDC or less Current consumption: 5 mA or less	Connected to DC (+) Voltage range: 19 VDC to power supply voltage Current consumption: 5 mA or less	—
Output signal*4	Max. load current: 100 mA Residual voltage: 1 V or less (Load current at 100 mA) Max. applied voltage: 26.4 VDC	Max. load current: 100 mA Residual voltage: 1 V or less (Load current at 100 mA)	—
IO-Link communication*5	—	—	Voltage range: 18 to 30 VDC Current consumption: 100 mA or less For details, refer to the "IO-Link Communication Specifications" table below.
Function	Auto balance, Maintenance detection, High voltage abnormality detection (Ion generation stops when an abnormality is detected.), and Ion generation stop input		
Effective static neutralization distance	50 to 2000 mm		
Frequency setting (Max.)	100 Hz		
Ambient and fluid temperatures	0 to +40°C		
Ambient humidity	35 to 80%Rh (No condensation)		
IP degrees of protection	IP30		
Standards	CE (EMC directive, RoHS directive), UKCA		

*1 Apply cathode or anode to DC.

*2 Measured value with a high voltage probe (1000 MΩ, 5 pF).

*3 With air purge at a distance of 300 mm between the workpiece and ionizer.

*4 Transistor input/output type

*5 IO-Link type

IO-Link Communication Specifications

IO-Link type	Device
IO-Link version	V1.1
Configuration file format	IODD file*1
Communication speed	COM2 (38.4 kbps)
Min. cycle time	8.0 ms
Process data length	Input data: 3 bytes, Output data: 2 bytes
On request data communication	Yes
Data storage function	Yes
Event function	Yes
Vendor ID	131 (0 x 0083)
Device ID	666 (0 x 00029A)

*1 The configuration file can be downloaded from the SMC website.

Emitter Cartridge Quantity, Weight

Symbol for bar length	35	38	44	56	62	80	110	128	158	188	230	248
Emitter cartridge quantity	5	6	7	9	10	13	18	21	26	31	38	41
Weight [g]	730	772	844	959	1018	1192	1483	1658	1948	2238	2645	2819

AC Adapter (Accessories Sold Separately)

Model	IZS51-CG1, IZS51-CG2
Input voltage	100 to 240 VAC, 50/60 Hz
Output current	1.9 A
Ambient temperature	0 to 40°C
Ambient humidity	35 to 65%Rh (No condensation)
Weight	365 g (IZS51-CG1), 200 g (IZS51-CG2)
Standards/Directive	CE/UKCA, UL, CSA

* The included AC cable is for use in Japan only (Rated voltage 125 V, Plug JIS C 8303, Inlet IEC 60320-C6).

IZS51 Series

Accessories / Accessories Sold Separately (for Individual Parts)

Emitter cartridge

IZS51-N **T**

Symbol	Cartridge type	Emitter material	Nozzle color	Cartridge color
T	High flow cartridge	Tungsten	Blue	White
C		Silicon		Gray
J	Middle flow cartridge	Tungsten	Gray	White
K		Silicon		Gray
V	Low flow cartridge	Tungsten	Black	White
S		Silicon		Gray

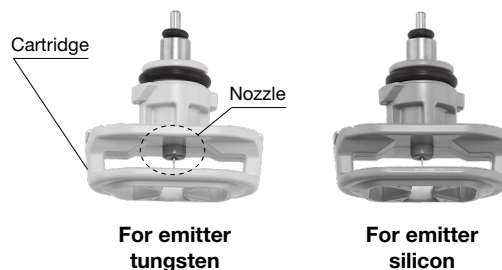

AC adapter

IZS51-C **G1**

G1	With AC cable
G2	Without AC cable

Bracket

IZS51-B **E1**

Symbol	Bracket type
E1	End bracket 1
M1	Intermediate bracket 1
E2	End bracket 2
M2	Intermediate bracket 2

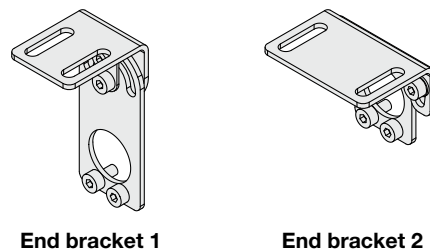

* Refer to the table below for selecting a bracket.

Bracket combinations

	Intermediate bracket 1	Intermediate bracket 2
End bracket 1	○ (Adjustment angle $\pm 90^\circ$)	×
End bracket 2	×	○ (Adjustment angle $\pm 10^\circ$)

○: Available ×: Not available

Number of brackets

Bar length symbol	End bracket	Intermediate bracket
35 to 62	2	None
80 to 158		1
188 to 230		2
248		3

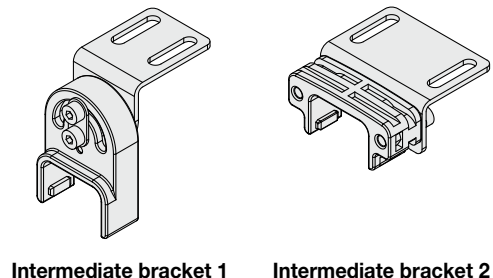

Power supply cable (For transistor input/output type)

IZS51-CP **03**

Symbol	Length
03	3 m
05	5 m
10	10 m

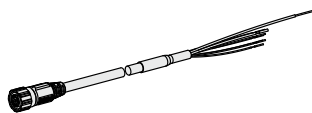

Communication cable (For IO-Link type)

IZS51-CE **S5**

Symbol	Length
S5	0.5 m
01	1 m
03	3 m

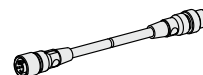

Power supply cable (For IO-Link type)

IZS51-CQ **S5**

Symbol	Length
S5	0.5 m
01	1 m
03	3 m

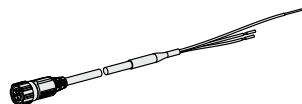

Relay cable (For IO-Link type)

IZS51-CF **03**

Symbol	Length
03	3 m
05	5 m
10	10 m

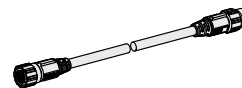

* A T-branch connector is not provided.

Accessories / Accessories Sold Separately (for Individual Parts)

Cleaning kit

IZS51-M 3

3	Cleaning kit (for bulk cleaning)
3B	Replacement brush (2 pcs.)

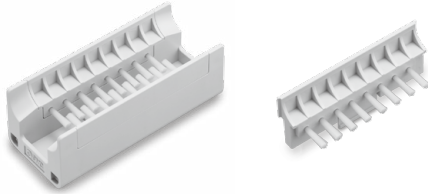

Cleaning kit

IZT43-M2



IZT43-A003: Replacement felt
IZT43-A004: Replacement rubber grind stone

T-connector

IZS51-CT



Remote controller

IZS51-RC



Drop prevention cover

IZS51-E 3

Symbol	Number of emitter cartridges to be fixed
3	3
4	4
5	5

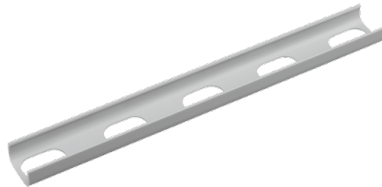

Power supply cable (For NPN/PNP) intermediate length

IZS51-CP 01 -X13

01	Power supply cable (1 m)	13	Power supply cable (13 m)
02	Power supply cable (2 m)	14	Power supply cable (14 m)
04	Power supply cable (4 m)	15	Power supply cable (15 m)
06	Power supply cable (6 m)	16	Power supply cable (16 m)
07	Power supply cable (7 m)	17	Power supply cable (17 m)
08	Power supply cable (8 m)	18	Power supply cable (18 m)
09	Power supply cable (9 m)	19	Power supply cable (19 m)
11	Power supply cable (11 m)	20	Power supply cable (20 m)
12	Power supply cable (12 m)		

Symbol for bar length	Number of required drop prevention covers		
	IZS51-E3	IZS51-E4	IZS51-E5
35	—	—	1
38	2	—	—
44	1	1	—
58	—	1	1
62	—	—	2
80	1	—	2
110	1	—	3
128	2	—	3
158	2	—	4
188	2	—	5
220	1	—	7
248	2	—	7

Relay cable (For IO-Link type) intermediate length

IZS51-CF 01 -X13

Symbol	Length
01	1 m
02	2 m
04	4 m
06	6 m
07	7 m
08	8 m
09	9 m

* A T-branch connector is not provided.

IZS51 Series

Wiring Circuit/IZS51-N, IZS51-P

Ionizer NPN input/output

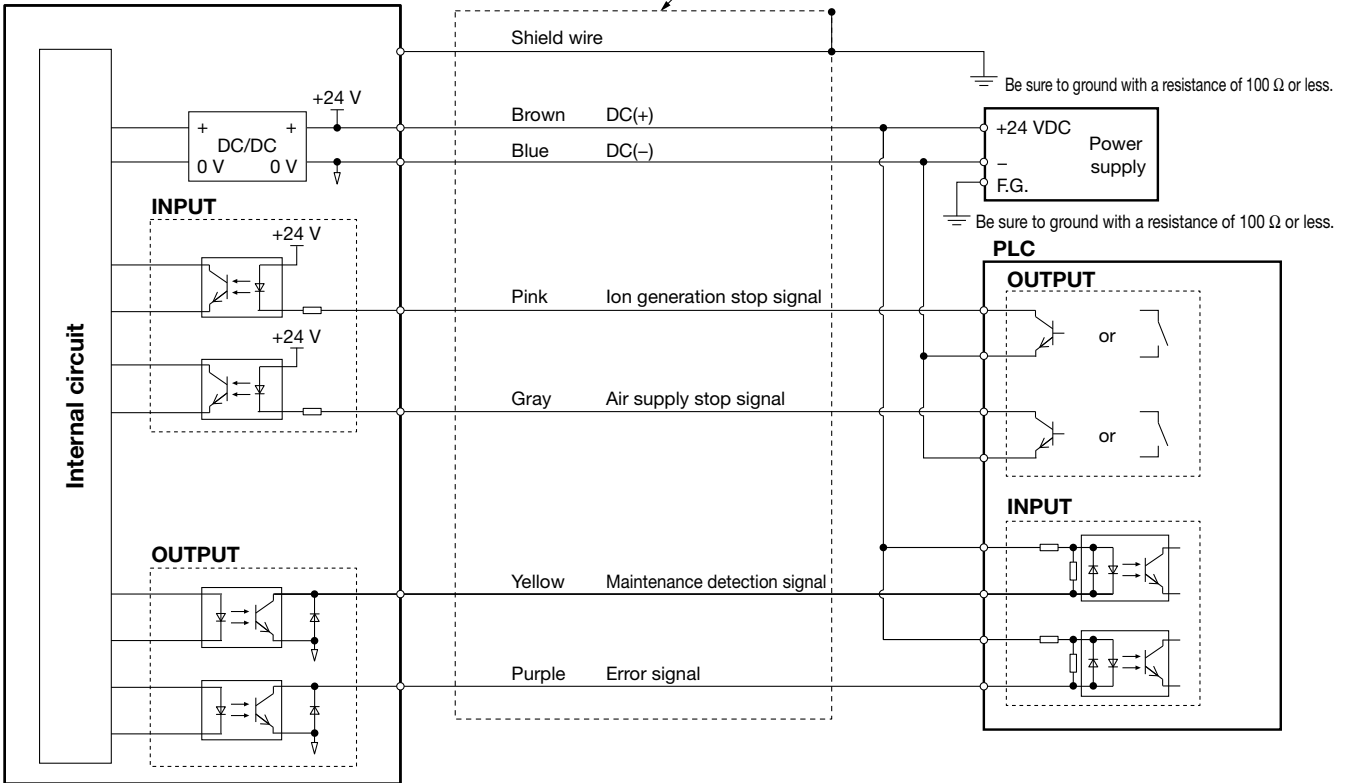

Ionizer PNP input/output

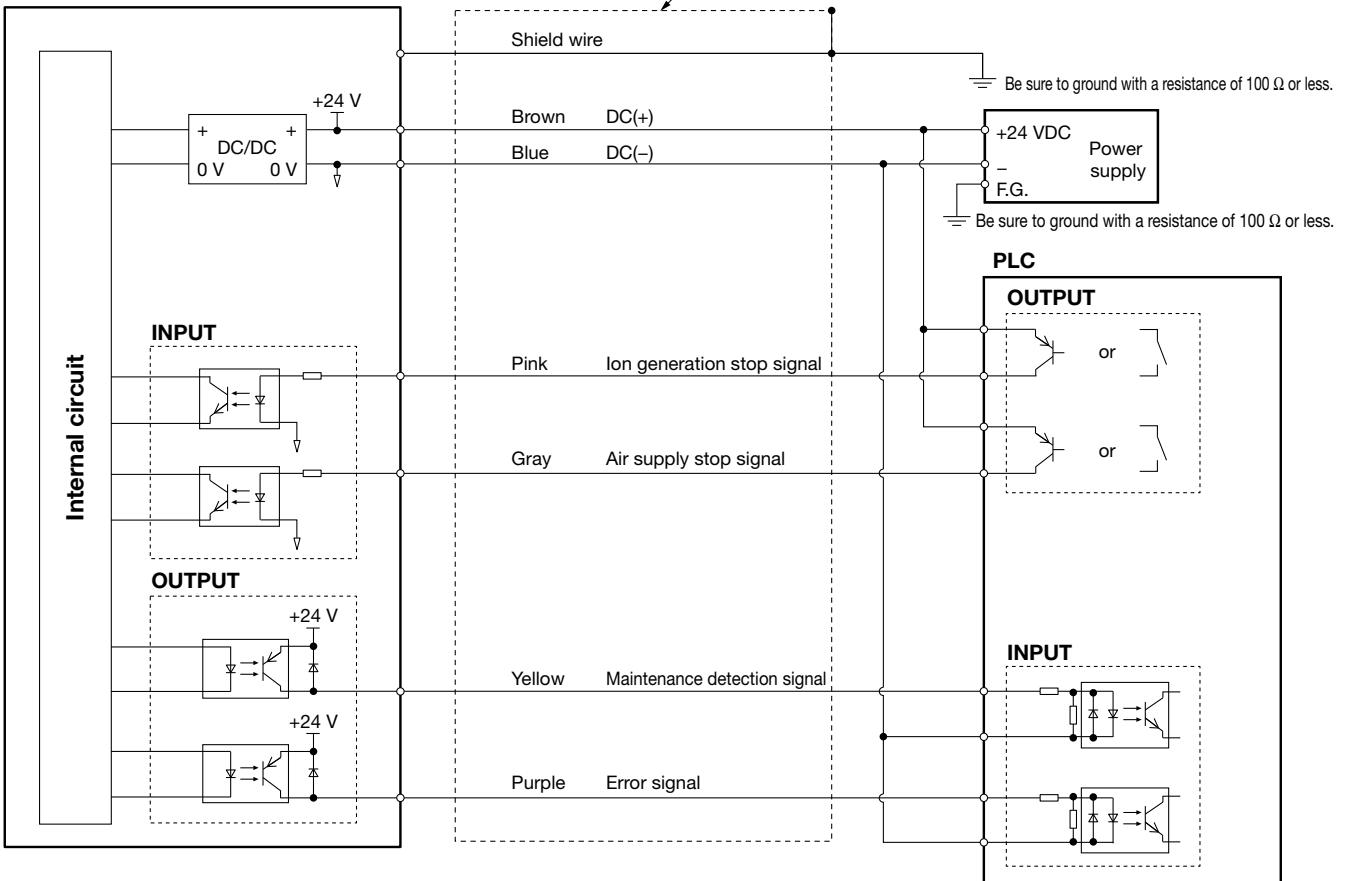

Wiring Circuit/IZS51-L

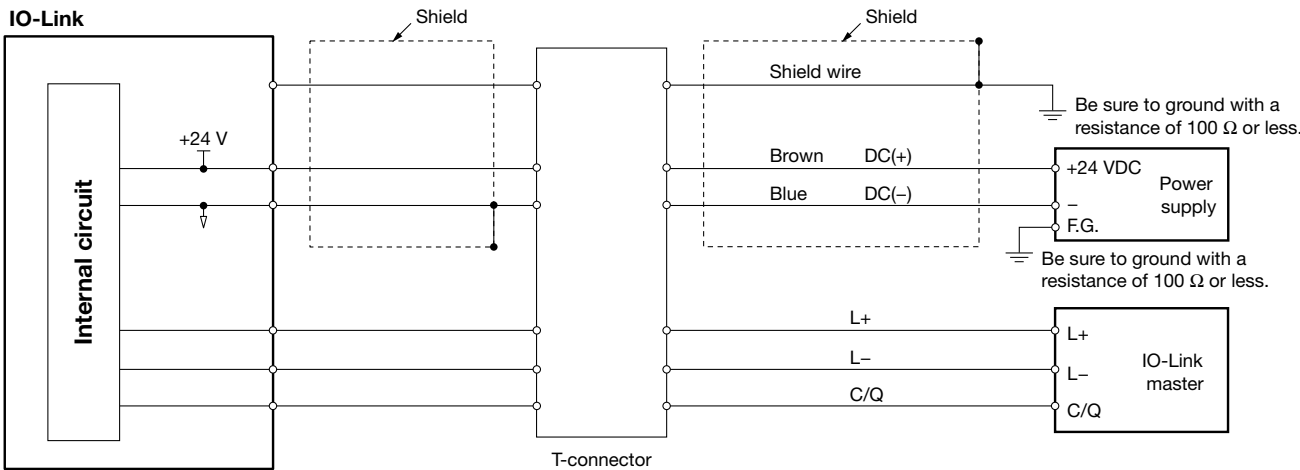

IZS51 Series

Dimensions

Ionizer/IZS51-350

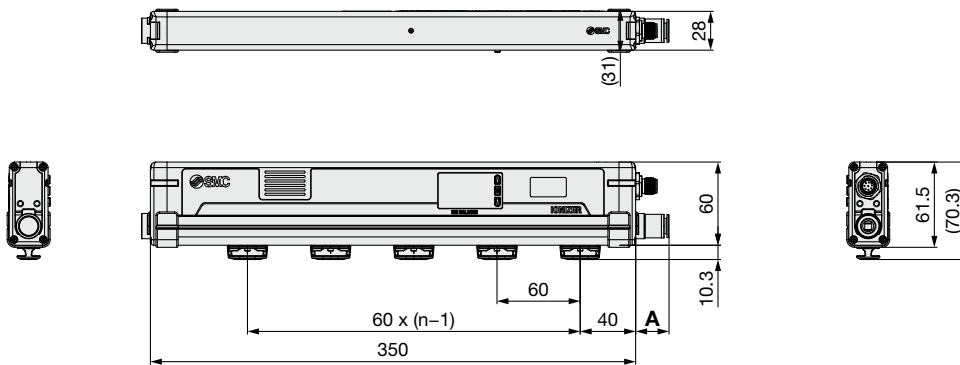

Ionizer/IZS51-380 to 2480

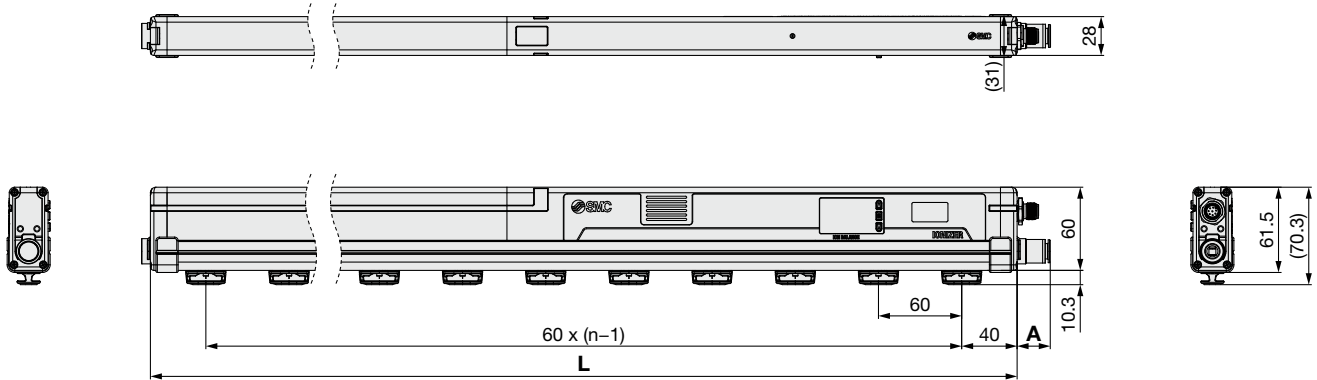

Ionizer with the valve unit/IZS51-V

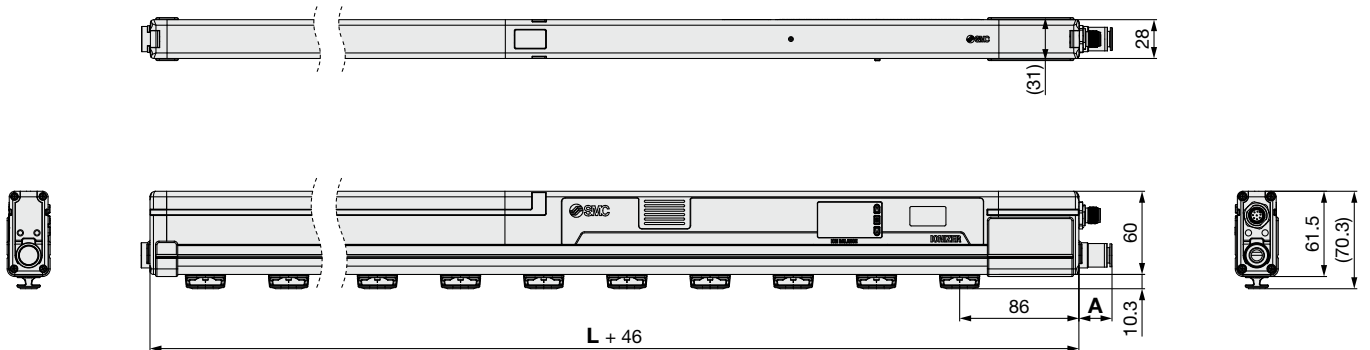

Number of Emitter Cartridges n

Bar Length L

Part no.	n [pcs.]	L [mm]
IZS51-35	5	350
IZS51-38	6	380
IZS51-44	7	440
IZS51-56	9	560
IZS51-62	10	620
IZS51-80	13	800
IZS51-110	18	1100
IZS51-128	21	1280
IZS51-158	26	1580
IZS51-188	31	1880
IZS51-230	38	2300
IZS51-248	41	2480

One-touch Fittings Straight

	Applicable tubing O.D.	A [mm]
Metric	ø4	15
	ø6	15
	ø8	17
	ø10	24
Inch	ø3/16"	17
	ø1/4"	16
	ø5/16"	17
	ø3/8"	25

Dimensions

End bracket 1/IZS51-BE1

Intermediate bracket 1/IZS51-BM1

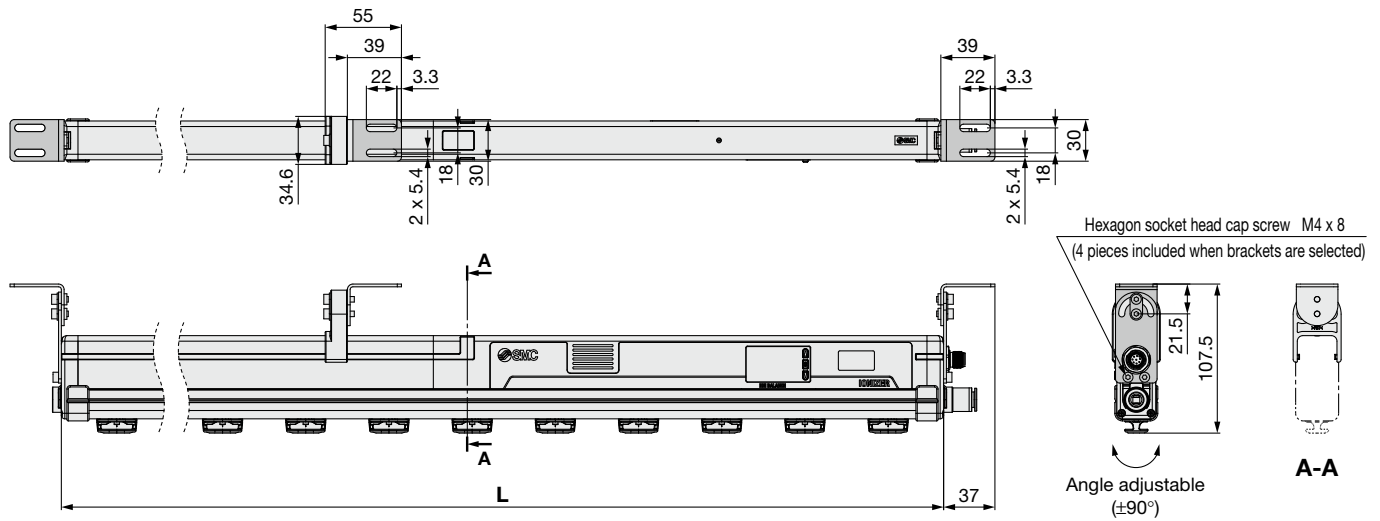

End bracket 2/IZS51-BE2

Intermediate bracket 2/IZS51-BM2

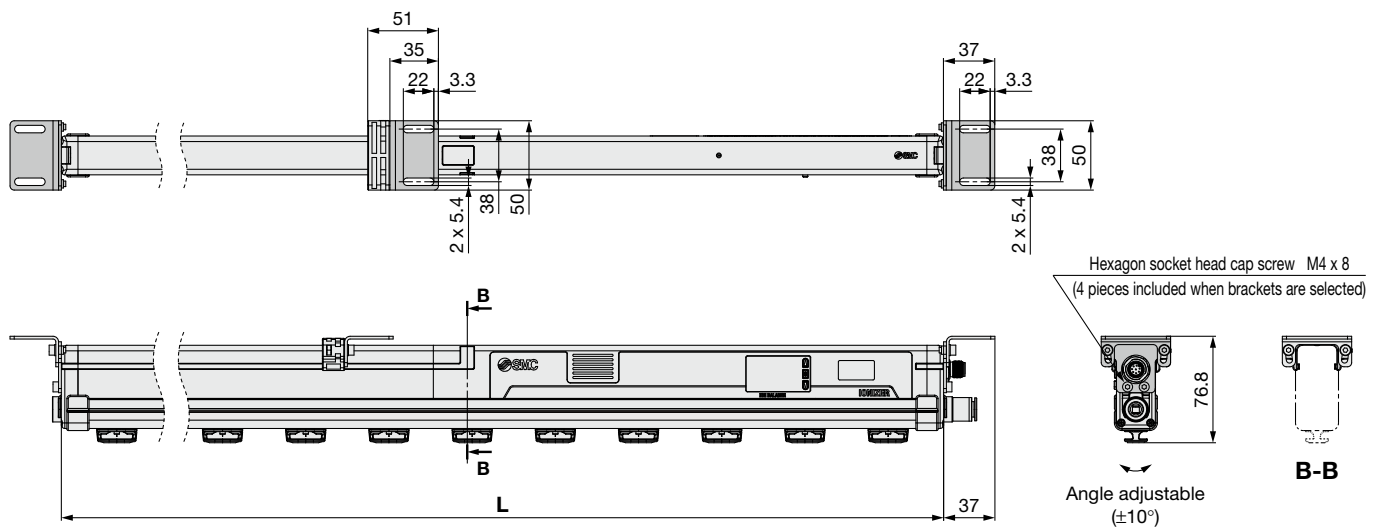

Number of Emitter Cartridges n

Bar Length L

Part no.	n [pcs.]	L [mm]
IZS51-35	5	350
IZS51-38	6	380
IZS51-44	7	440
IZS51-56	9	560
IZS51-62	10	620
IZS51-80	13	800
IZS51-110	18	1100
IZS51-128	21	1280
IZS51-158	26	1580
IZS51-188	31	1880
IZS51-230	38	2300
IZS51-248	41	2480

One-touch Fittings Straight

	Applicable tubing O.D.	A [mm]
Metric	ø4	15
	ø6	15
	ø8	17
	ø10	24
Inch	ø3/16"	17
	ø1/4"	16
	ø5/16"	17
	ø3/8"	25

IZS51 Series

Dimensions

Power supply cable/IZS51-CP

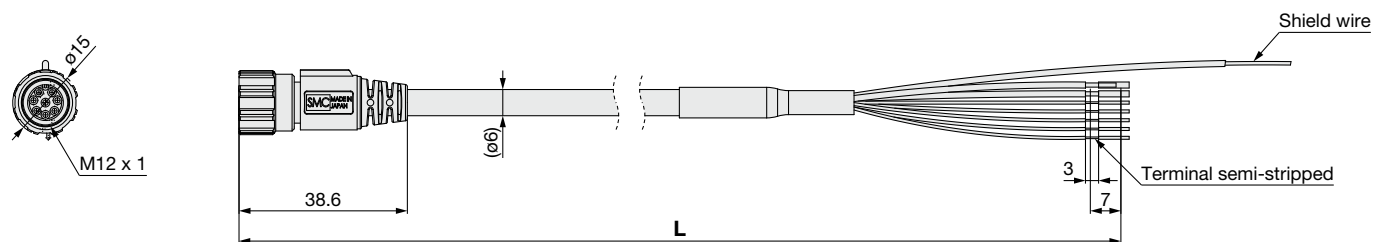

Cable Length L

Part number	L [mm]
IZS51-CP03	3000
IZS51-CP05	5000
IZS51-CP10	9800

Power Supply Cable Specifications

Conductor	Number of wire cores	7 and shield wire
	Size	AWG20 (2 cores), AWG28 (5 cores)
Insulator	O.D.	1.55 mm (Brown, Blue)
		0.95 mm (Pink, Purple, Gray, Yellow, White)
Sheath	Material	PVC (Lead-free)
	O.D.	6 mm

IO-Link power supply cable/IZS51-CQ

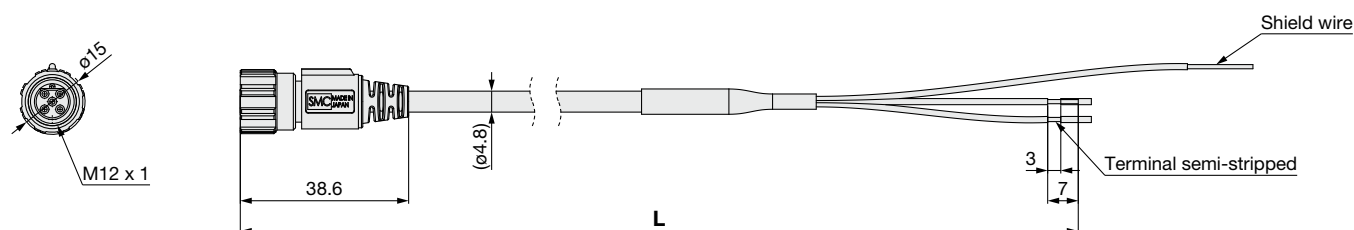

Power Supply Cable Length L

Part number	L [mm]
IZS51-CQS5	500
IZS51-CQ01	1000
IZS51-CQ03	3000

Power Supply Cable Specifications

Conductor	Number of wire cores	2 and shield wire
	Size	AWG20 (2 cores)
Insulator	O.D.	1.55 mm (Brown, Blue)
Sheath	Material	PVC (Lead-free)
	O.D.	4.8 mm

Relay cable (For IO-Link type)/IZS51-CF

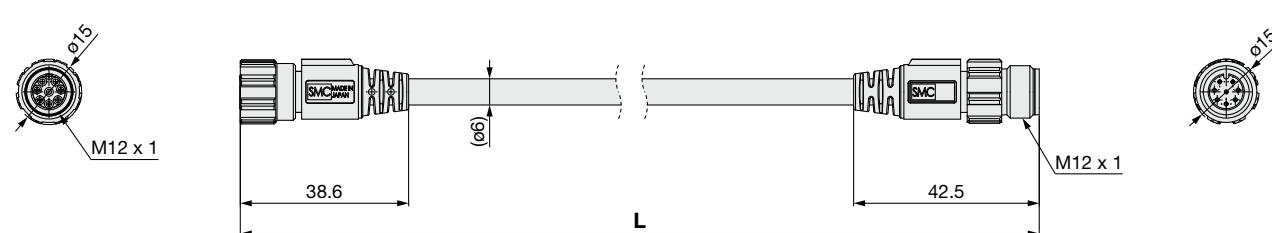

Relay Cable Length L

Part number	L [mm]
IZS51-CF03	3000
IZS51-CF05	5000
IZS51-CF10	9800

Relay Cable Specifications

Conductor	Number of wire cores	7 and shield wire
	Size	AWG20 (2 cores), AWG28 (5 cores)
Insulator	O.D.	1.55 mm (2 cores)
		0.95 mm (5 cores)
Sheath	Material	PVC (Lead-free)
	O.D.	6 mm

Dimensions

IO-Link communication cable/IZS51-CE

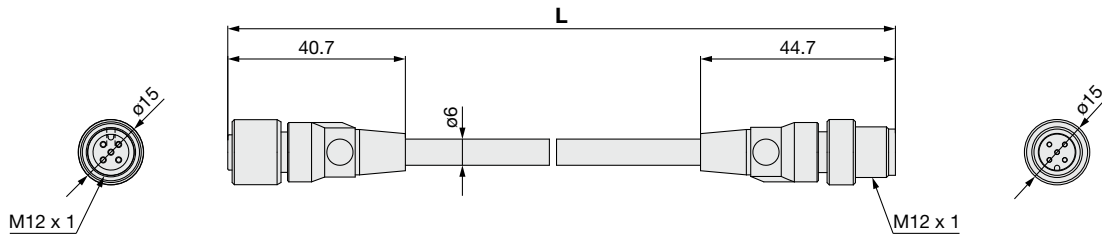

Communication Cable Length L

Part number	L [mm]
IZS51-CES5	500
IZS51-CE01	1000
IZS51-CE03	3000

Communication Cable Specifications

Conductor	Number of wire cores	5 cores
	Size	AWG22
	Nominal cross section	0.3 mm ²
Insulator	O.D.	1.5 mm
	Material	PVC (Lead-free)
Sheath	O.D.	6.0 mm

T-connector/IZS51-CT

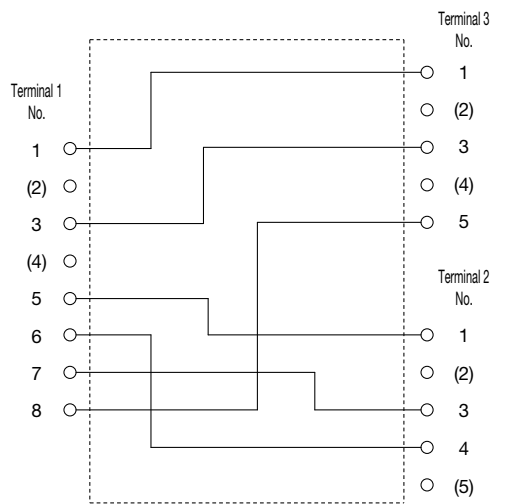
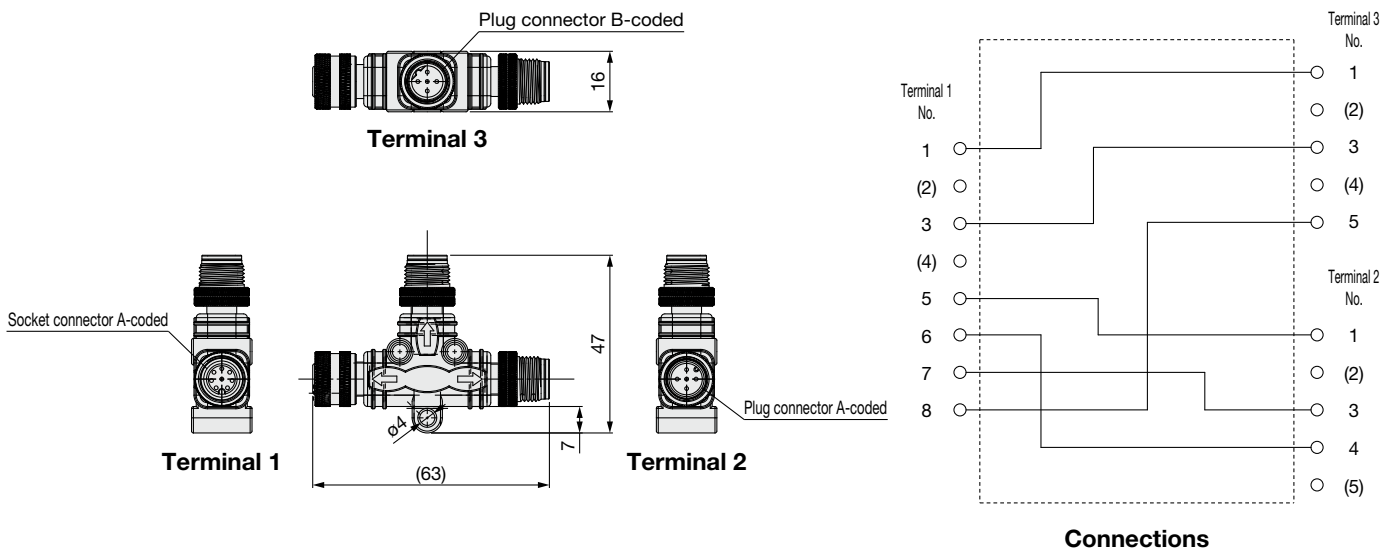



Connections

Safety Instructions

These safety instructions are intended to prevent hazardous situations and/or equipment damage. These instructions indicate the level of potential hazard with the labels of “**Caution**,” “**Warning**” or “**Danger**.” They are all important notes for safety and must be followed in addition to International Standards (ISO/IEC)*1), and other safety regulations.

 **Danger :** **Danger** indicates a hazard with a high level of risk which, if not avoided, will result in death or serious injury.

 **Warning:** **Warning** indicates a hazard with a medium level of risk which, if not avoided, could result in death or serious injury.

 **Caution:** **Caution** indicates a hazard with a low level of risk which, if not avoided, could result in minor or moderate injury.

*1) ISO 4414: Pneumatic fluid power - General rules and safety requirements for systems and their components
ISO 4413: Hydraulic fluid power - General rules and safety requirements for systems and their components
IEC 60204-1: Safety of machinery - Electrical equipment of machines - Part 1: General requirements
ISO 10218-1: Robots and robotic devices - Safety requirements for industrial robots - Part 1: Robots etc.

Warning

1. The compatibility of the product is the responsibility of the person who designs the equipment or decides its specifications.

Since the product specified here is used under various operating conditions, its compatibility with specific equipment must be decided by the person who designs the equipment or decides its specifications based on necessary analysis and test results. The expected performance and safety assurance of the equipment will be the responsibility of the person who has determined its compatibility with the product. This person should also continuously review all specifications of the product referring to its latest catalog information, with a view to giving due consideration to any possibility of equipment failure when configuring the equipment.

2. Only personnel with appropriate training should operate machinery and equipment.

The product specified here may become unsafe if handled incorrectly. The assembly, operation and maintenance of machines or equipment including our products must be performed by an operator who is appropriately trained and experienced.

3. Do not service or attempt to remove product and machinery/equipment until safety is confirmed.

1. The inspection and maintenance of machinery/equipment should only be performed after measures to prevent falling or runaway of the driven objects have been confirmed.
2. When the product is to be removed, confirm that the safety measures as mentioned above are implemented and the power from any appropriate source is cut, and read and understand the specific product precautions of all relevant products carefully.
3. Before machinery/equipment is restarted, take measures to prevent unexpected operation and malfunction.

4. SMC products cannot be used beyond their specifications. They are not developed, designed, and manufactured to be used under the following conditions or environments. Use under such conditions or environments is not allowed.

1. Conditions and environments outside of the given specifications, or use outdoors or in a place exposed to direct sunlight.
2. Use for nuclear power, railways, aviation, space equipment, ships, vehicles, military application, equipment affecting human life, body, and property, combustion equipment, entertainment equipment, emergency shut-off circuits, press clutches, brake circuits, safety equipment, etc., and use for applications that do not conform to standard specifications such as catalogs and operation manuals.
3. Use for interlock circuits, except for use with double interlock such as installing a mechanical protection function in case of failure. Please periodically inspect the product to confirm that the product is operating properly.

Caution

SMC develops, designs, and manufactures products to be used for automatic control equipment, and provides them for peaceful use in manufacturing industries.

Use in non-manufacturing industries is not allowed.

Products SMC manufactures and sells cannot be used for the purpose of transactions or certification specified in the Measurement Act of each country. The new Measurement Act prohibits use of any unit other than SI units in Japan.

Limited warranty and Disclaimer/ Compliance Requirements

The product used is subject to the following “Limited warranty and Disclaimer” and “Compliance Requirements”.

Read and accept them before using the product.

Limited warranty and Disclaimer

1. The warranty period of the product is 1 year in service or 1.5 years after the product is delivered, whichever is first.*2)
Also, the product may have specified durability, running distance or replacement parts. Please consult your nearest sales branch.
2. For any failure or damage reported within the warranty period which is clearly our responsibility, a replacement product or necessary parts will be provided.
This limited warranty applies only to our product independently, and not to any other damage incurred due to the failure of the product.
3. Prior to using SMC products, please read and understand the warranty terms and disclaimers noted in the specified catalog for the particular products.

*2) **Suction cups (Vacuum pads) are excluded from this 1 year warranty.**

A suction cup (vacuum pad) is a consumable part, so it is warranted for a year after it is delivered.

Also, even within the warranty period, the wear of a product due to the use of the suction cup (vacuum pad) or failure due to the deterioration of rubber material are not allowed by the limited warranty.

Compliance Requirements

1. The use of SMC products with production equipment for the manufacture of weapons of mass destruction (WMD) or any other weapon is strictly prohibited.
2. The exports of SMC products or technology from one country to another are governed by the relevant security laws and regulations of the countries involved in the transaction. Prior to the shipment of a SMC product to another country, assure that all local rules governing that export are known and followed.

Safety Instructions

Be sure to read the “Handling Precautions for SMC Products” (M-E03-3) and “Operation Manual” before use.