

Lever Hand Valve

New

RoHS

Space saving, Easy to operate

(Vertical type) 5-Port Lever Valve

3 operation types **p. 3**

- Spring return
- Detent
- Detent type with shift prevention lock

Weight reduction of
up to **45%**

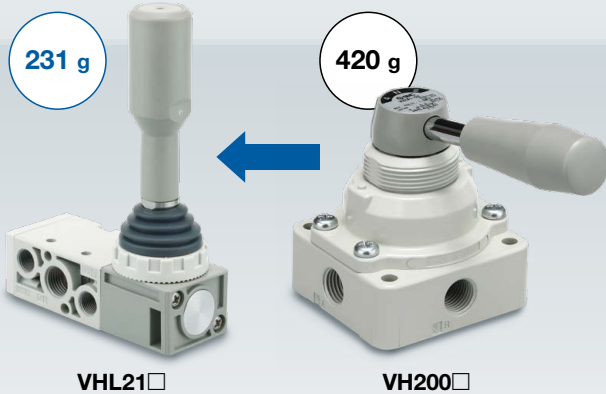

* Comparison between VHL21□D-02□ and VH210-□02

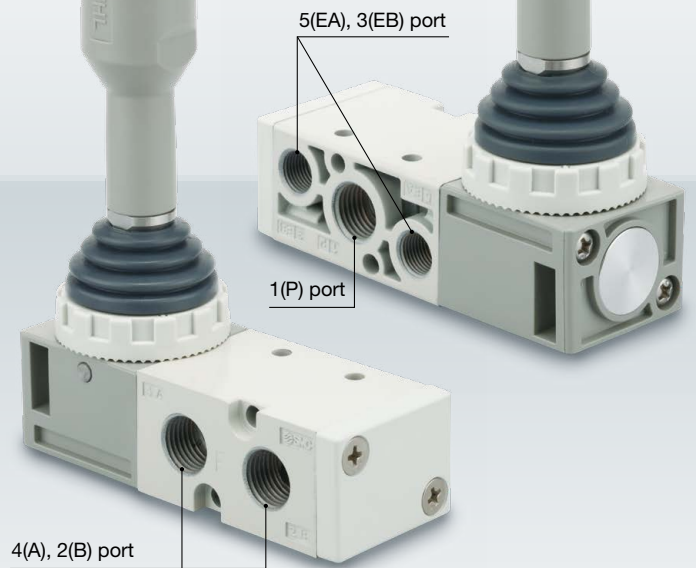

Footprint reduced by **58%**

VHL210D 3216.5 mm² ← VH20□ 7750 mm²

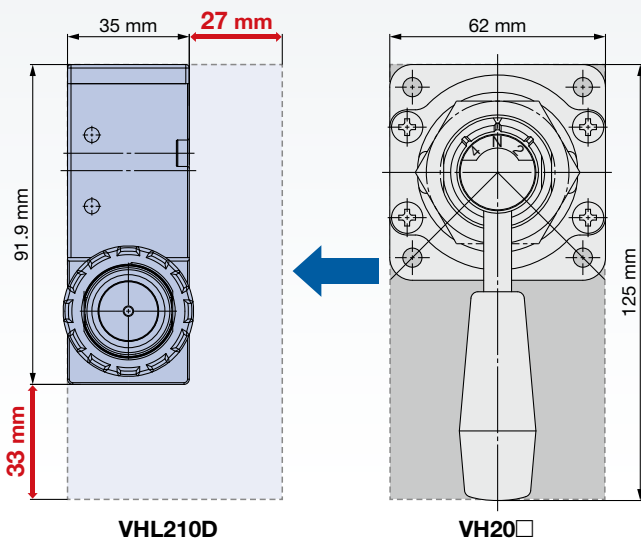

Panel mounting internal

height reduced by **18.6 mm**

For panel mounting

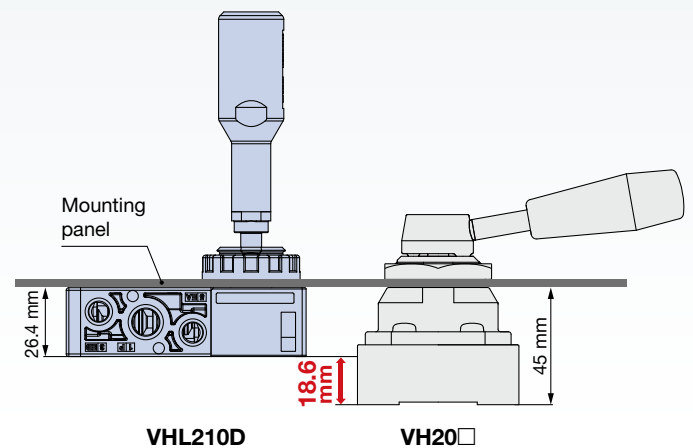

* Comparison between VHL210D and the existing VH20□ model

Flow rate increased by **73%**

* Comparison between VH211□-02□ and VH210-□02 (Flow rate characteristics 1 → 4/2 (P → A/B))

VHL Series



CAT.ES13-13A

2 mounting options available



Direct mounting



Panel mounting

Features unintentional operation prevention

Operation requires additional action to shift.

Shift prevention lock The product can only be switched after the button has been pushed.

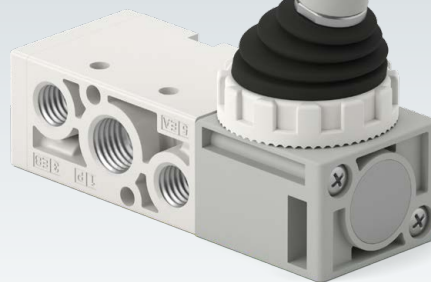
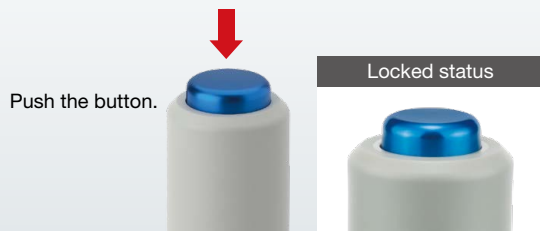

CONTENTS

Specifications	p. 2	Operation Variations	p. 3
Flow Rate Characteristics	p. 2	Dimensions	p. 4
How to Order	p. 2	Specific Product Precautions	p. 7
Flow Direction in Lever Positions	p. 3		

Lever Hand Valve

VHL Series

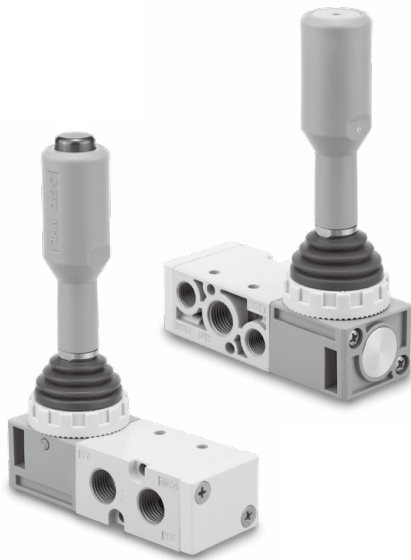

Specifications

Operation type	Spring return	Detent
Fluid	Air	
Operating pressure range	-0.1 to 1.0 MPa	
Ambient and fluid temperatures	-10 to 60°C (No freezing)	
Option	—	Shift prevention lock

Flow Rate Characteristics

Model	Port size		Type of actuation	Flow rate characteristics*1					
	1, 4, 2 (P, A, B)	5, 3 (EA, EB)		1 → 4/2 (P → A/B)			4/2 → 5/3 (A/B → EA/EB)		
				C [dm ³ / (s·bar)]	b	Cv	C [dm ³ / (s·bar)]	b	Cv
VHL210			3-position closed center	2.4	0.31	0.64	1.8	0.37	0.46
VHL211	1/4	1/8	3-position exhaust center	2.6	0.37	0.7	3 [2.5]	0.32 [0.28]	0.76 [0.62]
VHL212			2-position	3	0.38	0.78	2.8	0.3	0.67

*1 []: Denotes the normal position.

How to Order

VHL 21 1 S - 02

Body size

2	1/4 standard
---	--------------

Type of actuation

0	3-position closed center
1	3-position exhaust center
2	2-position

Port size

02	1/4
----	-----

Operation type

S	Spring return
D	Detent
W	Detent type with shift prevention lock

Thread type

Nil	R
N	NPT
G	G

* For the spring return and detent types, the handle, dust boot, and set nut are shipped together but not assembled. For how to assemble these parts, please refer to the operation manual. The detent type with shift prevention lock will be shipped assembled since its handle is non-detachable. (See page 8.)

VHL Series

Flow Direction in Lever Positions

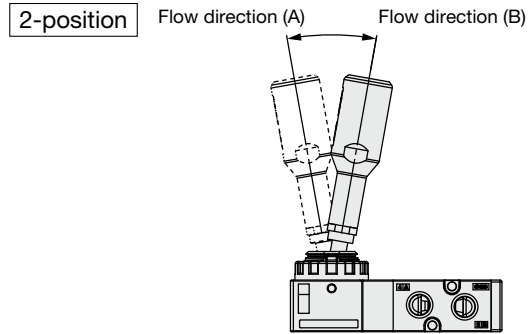
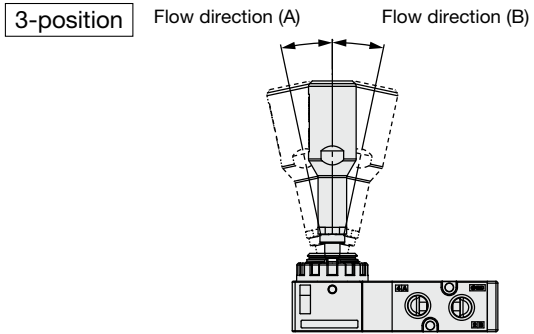

* The operation methods of the spring return and the detent type with shift prevention lock, differ from each other. For details, please refer to the Operation Variations below.

Symbol

Model	Symbol	Type of actuation	Operation type	Weight [g]
VHL210S□	(A)4 2(B) (EA)5 1(P) 3(EB)	3-position closed center	Spring return	248
VHL210D□	(A)4 2(B) (EA)5 1(P) 3(EB)		Detent	231
VHL210W□	(A)4 2(B) (EA)5 1(P) 3(EB)		Detent type with shift prevention lock	249
VHL211S□	(A)4 2(B) (EA)5 1(P) 3(EB)	3-position exhaust center	Spring return	248
VHL211D□	(A)4 2(B) (EA)5 1(P) 3(EB)		Detent	231
VHL211W□	(A)4 2(B) (EA)5 1(P) 3(EB)		Detent type with shift prevention lock	249

Model	Symbol	Type of actuation	Operation type	Weight [g]
VHL212S□	(A)4 2(B) (EA)5 1(P) 3(EB)	2-position	Spring return	249
VHL212D□	(A)4 2(B) (EA)5 1(P) 3(EB)		Detent	232
VHL212W□	(A)4 2(B) (EA)5 1(P) 3(EB)		Detent type with shift prevention lock	251

Operation Variations

Spring type Returns to the initial position once the lever is released.

Detent type The lever holds its position after release.

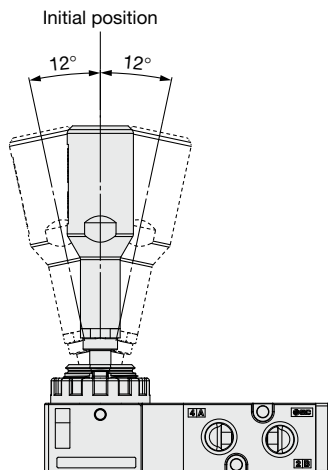

3-position

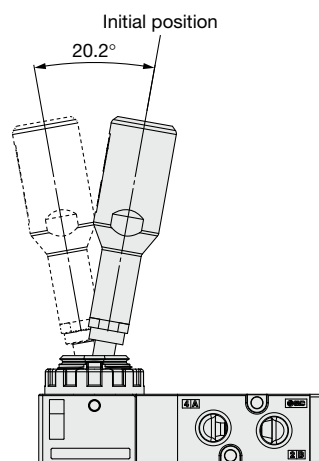

2-position

Detent type with shift prevention lock

The lever is held in the locked position. To release the lock, push the handle button.

The lever can only be operated whilst the button is being pushed down.

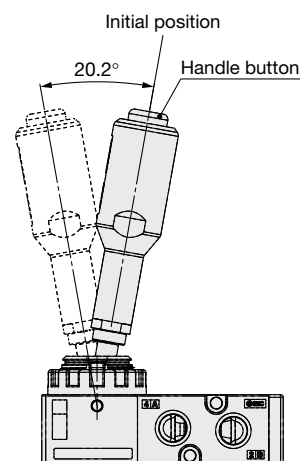

Dimensions

**3-Position Closed Center, Exhaust Center / Spring Return
VHL210S/VHL211S**

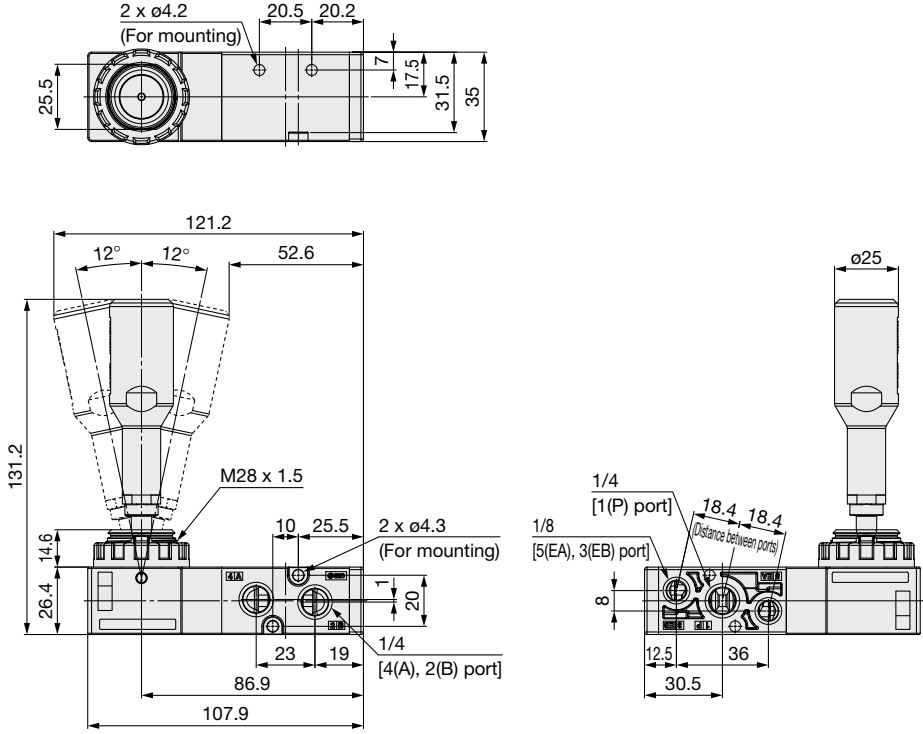

Panel cutout dimensions

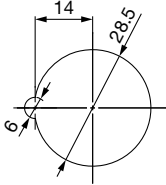
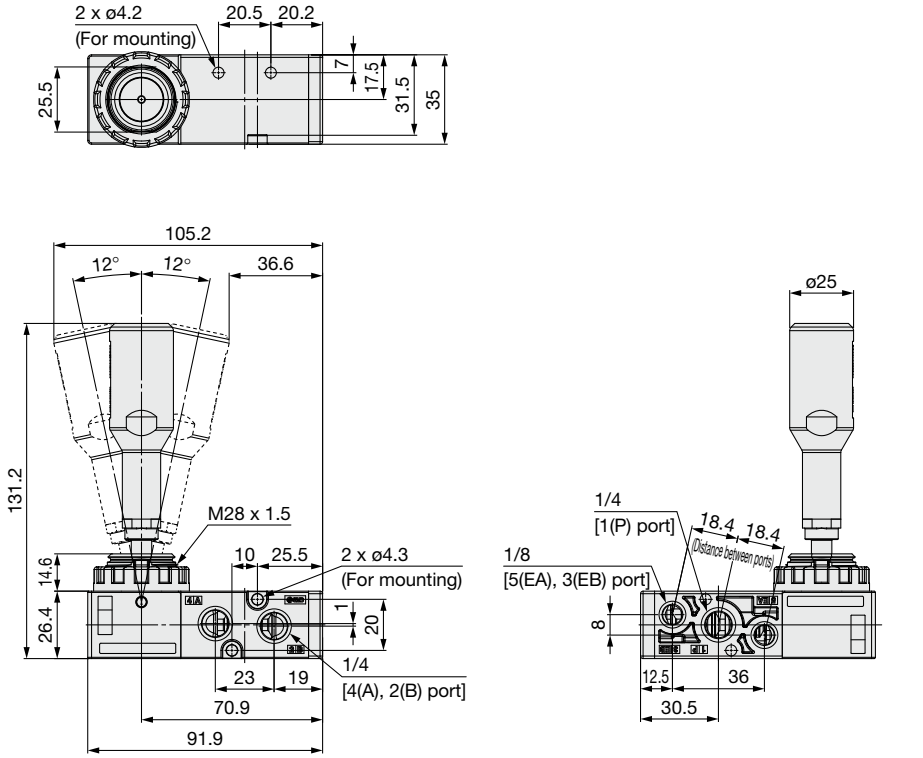

Plate thickness
VHL21□S: Max. 3.5

**3-Position Closed Center, Exhaust Center / Detent
VHL210D/VHL211D**



Panel cutout dimensions

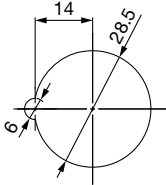

Plate thickness
VHL21□D: Max. 3.5

VHL Series

Dimensions

3-Position Closed Center, Exhaust Center / Detent Type with Shift Prevention Lock

VHL210W/VHL211W

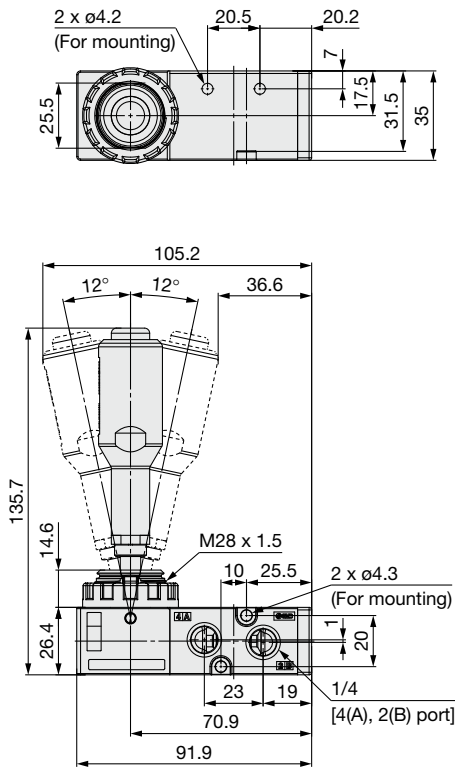

Panel cutout dimensions

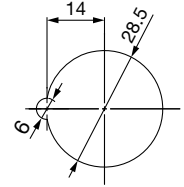
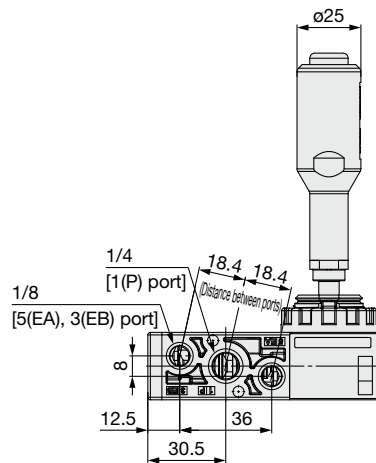
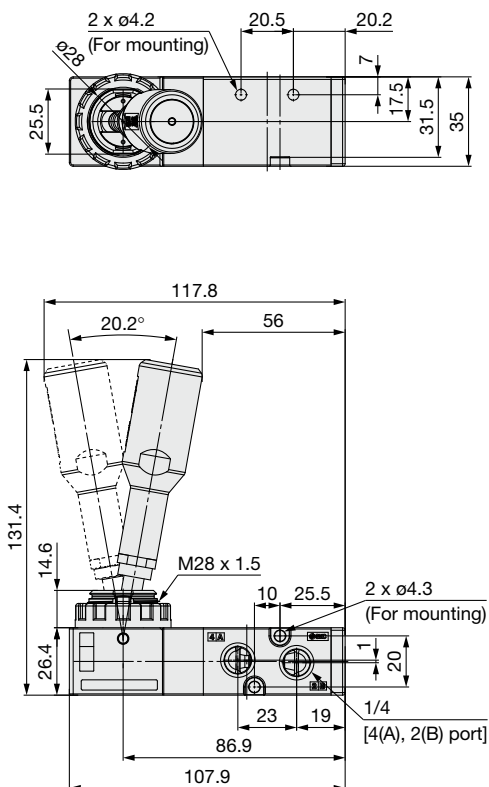

Plate thickness
VHL21□W: Max. 3.5



2-Position / Spring Return

VHL212S



Panel cutout dimensions

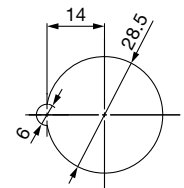
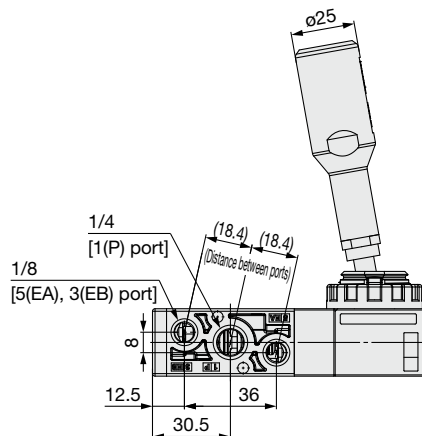
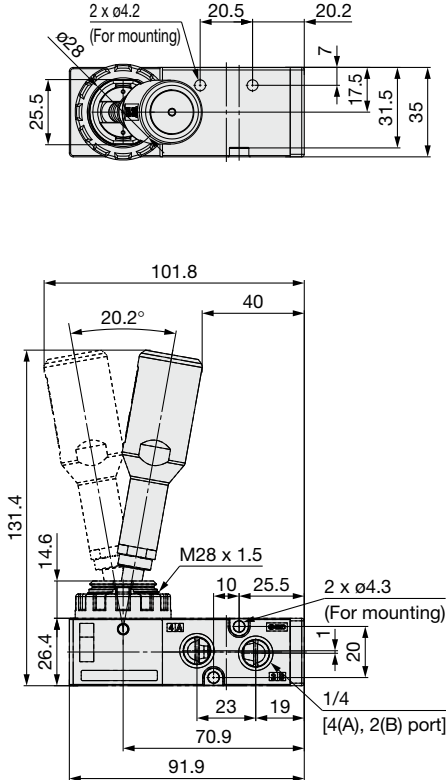

Plate thickness
VHL212S: Max. 3.5



Dimensions

**2-Position / Detent
VHL212D**



Panel cutout dimensions

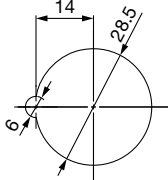
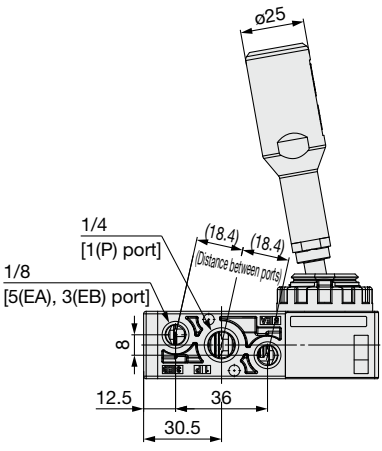
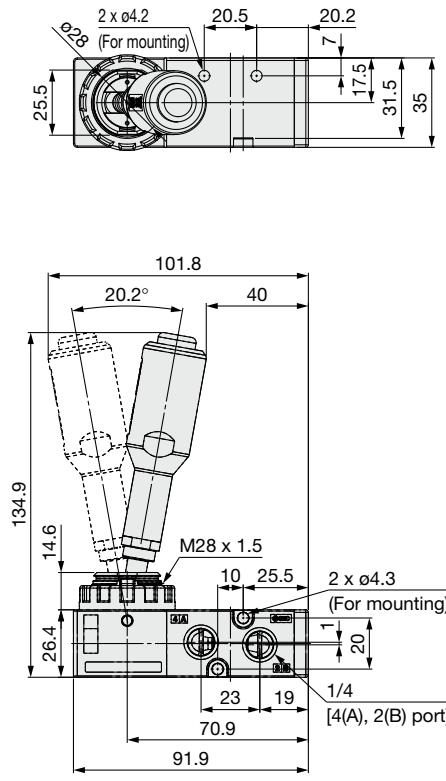

Plate thickness
VHL212D: Max. 3.5



**2-Position / Detent Type with Shift Prevention Lock
VHL212W**



Panel cutout dimensions

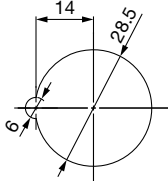
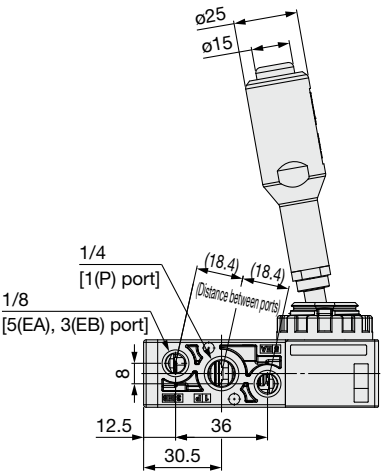

Plate thickness
VHL212W: Max. 3.5





VHL Series

Specific Product Precautions 1

Be sure to read this before handling the products. Refer to the back cover for safety instructions. For 3/4/5-port solenoid valve precautions, refer to the “Handling Precautions for SMC Products” and the “Operation Manual” on the SMC website.

Operation

⚠ Warning

1. Operation

The valve must be switched to each position instantly and securely. Stopping the handle between the extreme positions may cause malfunction.

This product is a directional control valve and not intended to be used for flow rate control. If this product is used to control the drive speed of an actuator or for any other unintended purpose without fully shifting the handle, the product may be damaged.

2. Switch the valve by hand.

If using a hammer or other tools or operating it mechanically through the use of a cylinder or the like, damage could result.

3. Move the handle in the correct direction.

Do not twist or shift the handle in other directions or the product may be damaged.

4. Ensure that the product is unlocked before moving the handle.

The detent type with shift prevention lock has a shift lock. Moving the handle with the lock engaged may damage the product.

5. If the product is subjected to prolonged operation, it may take some time for the valve to recover due to sticking of the seal.

Take due care when keeping the product in one energization state for an extended period of time.

Design

⚠ Warning

1. Check the specifications.

The product described in this catalog is designed to be used only in a compressed air system (including vacuum). Do not operate at pressures, temperatures, etc., beyond the range of specifications, as this can cause damage or malfunction. (Refer to the specifications.) SMC does not guarantee against any damage if the product is used outside of the specifications range.

2. Cannot be used for sealing pressure.

This product cannot be used for an application including vacuum in which the pressure must be sealed because there will be a slight leakage.

3. Cannot be used as an emergency shutoff valve.

The product is not designed for safety applications such as an emergency shutoff valve. If the product is used in this type of system, other reliable safety assurance measures should also be adopted.

4. The sonic conductance and the critical pressure ratio values for products are representative values.

Air Supply

⚠ Caution

1. Grease is applied to the inner parts of the valve.

Use caution since the grease may enter on the downstream side of the valve.

2. If excessive carbon powder is seen, install a mist separator on the upstream side of the valve.

If excessive carbon powder is generated by the compressor, it may adhere to the inside of the valves and cause malfunction. For compressed air quality, refer to SMC catalog “Compressed Air Purification System.”

Operating Environment

⚠ Warning

1. Avoid applying vibration or impact to the product.

Vibration and impact may cause the product to malfunction.

2. Do not expose the product to direct sunlight for an extended period of time

3. Employ suitable protective measures in a location where there is contact with oil or welding spatter, etc.

4. When the valve is exposed to a large amount of dust, install a silencer into the port “5(EA)” and “3(EB)”. When dust enters the valve from the port “5(EA)” or “3(EB)”, it may cause air leakage.

5. To prevent malfunction of this product due to water, oil, or dust entering the product through the lever opening, install the supplied dust boot before using the product.

Note that the dust boot is intended to prevent entry of large foreign matter and is not intended to provide a protective enclosure.



VHL Series

Specific Product Precautions 2

Be sure to read this before handling the products. Refer to the back cover for safety instructions. For 3/4/5-port solenoid valve precautions, refer to the “Handling Precautions for SMC Products” and the “Operation Manual” on the SMC website.

Maintenance

Warning

1. Perform inspection on a regular basis as necessary, such as at the beginning of operation, to make sure that the product operates properly.

2. Do not disassemble, repair or modify the product.

Doing so may cause malfunction of equipment, injury or equipment damage.

Note that the handle of the spring return and detent types is detachable.

The handle of the detent type with shift prevention lock type is non-detachable. Therefore, do not disassemble it.

For how to assemble these parts, please refer to the operation manual.

Component Parts

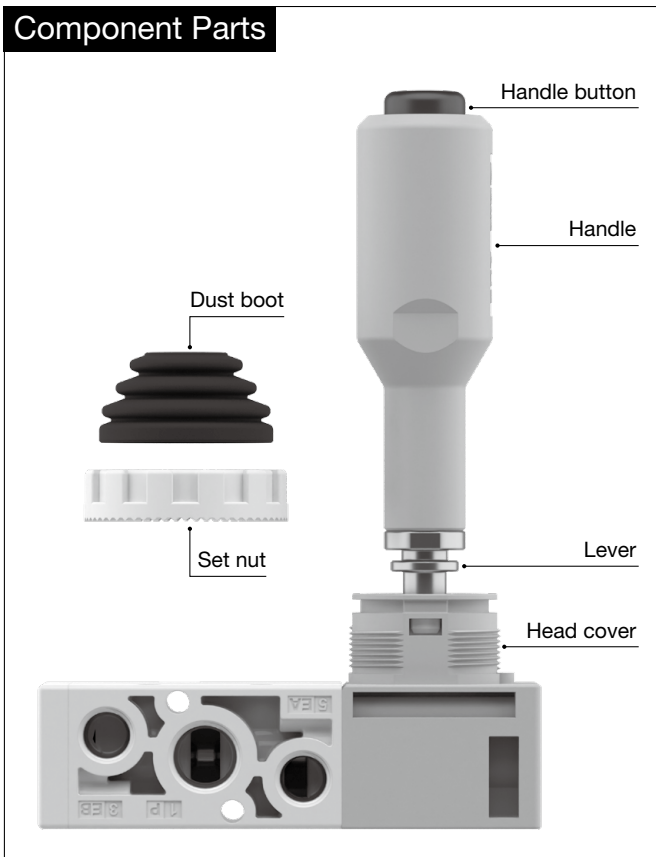

Safety Instructions

These safety instructions are intended to prevent hazardous situations and/or equipment damage. These instructions indicate the level of potential hazard with the labels of “**Caution**,” “**Warning**” or “**Danger**.” They are all important notes for safety and must be followed in addition to International Standards (ISO/IEC)*1), and other safety regulations.

 **Danger :** **Danger** indicates a hazard with a high level of risk which, if not avoided, will result in death or serious injury.

 **Warning:** **Warning** indicates a hazard with a medium level of risk which, if not avoided, could result in death or serious injury.

 **Caution:** **Caution** indicates a hazard with a low level of risk which, if not avoided, could result in minor or moderate injury.

*1) ISO 4414: Pneumatic fluid power - General rules and safety requirements for systems and their components
ISO 4413: Hydraulic fluid power - General rules and safety requirements for systems and their components
IEC 60204-1: Safety of machinery - Electrical equipment of machines - Part 1: General requirements
ISO 10218-1: Robots and robotic devices - Safety requirements for industrial robots - Part 1: Robots etc.

Warning

1. The compatibility of the product is the responsibility of the person who designs the equipment or decides its specifications.

Since the product specified here is used under various operating conditions, its compatibility with specific equipment must be decided by the person who designs the equipment or decides its specifications based on necessary analysis and test results. The expected performance and safety assurance of the equipment will be the responsibility of the person who has determined its compatibility with the product. This person should also continuously review all specifications of the product referring to its latest catalog information, with a view to giving due consideration to any possibility of equipment failure when configuring the equipment.

2. Only personnel with appropriate training should operate machinery and equipment.

The product specified here may become unsafe if handled incorrectly. The assembly, operation and maintenance of machines or equipment including our products must be performed by an operator who is appropriately trained and experienced.

3. Do not service or attempt to remove product and machinery/equipment until safety is confirmed.

1. The inspection and maintenance of machinery/equipment should only be performed after measures to prevent falling or runaway of the driven objects have been confirmed.
2. When the product is to be removed, confirm that the safety measures as mentioned above are implemented and the power from any appropriate source is cut, and read and understand the specific product precautions of all relevant products carefully.
3. Before machinery/equipment is restarted, take measures to prevent unexpected operation and malfunction.

4. SMC products cannot be used beyond their specifications. They are not developed, designed, and manufactured to be used under the following conditions or environments. Use under such conditions or environments is not allowed.

1. Conditions and environments outside of the given specifications, or use outdoors or in a place exposed to direct sunlight.
2. Use for nuclear power, railways, aviation, space equipment, ships, vehicles, military application, equipment affecting human life, body, and property, combustion equipment, entertainment equipment, emergency shut-off circuits, press clutches, brake circuits, safety equipment, etc., and use for applications that do not conform to standard specifications such as catalogs and operation manuals.
3. Use for interlock circuits, except for use with double interlock such as installing a mechanical protection function in case of failure. Please periodically inspect the product to confirm that the product is operating properly.

Caution

SMC develops, designs, and manufactures products to be used for automatic control equipment, and provides them for peaceful use in manufacturing industries.

Use in non-manufacturing industries is not allowed.

Products SMC manufactures and sells cannot be used for the purpose of transactions or certification specified in the Measurement Act of each country.

The new Measurement Act prohibits use of any unit other than SI units in Japan.

Limited warranty and Disclaimer/ Compliance Requirements

The product used is subject to the following “Limited warranty and Disclaimer” and “Compliance Requirements”.

Read and accept them before using the product.

Limited warranty and Disclaimer

1. The warranty period of the product is 1 year in service or 1.5 years after the product is delivered, whichever is first.*2)
Also, the product may have specified durability, running distance or replacement parts. Please consult your nearest sales branch.
2. For any failure or damage reported within the warranty period which is clearly our responsibility, a replacement product or necessary parts will be provided.
This limited warranty applies only to our product independently, and not to any other damage incurred due to the failure of the product.
3. Prior to using SMC products, please read and understand the warranty terms and disclaimers noted in the specified catalog for the particular products.

*2) **Vacuum pads are excluded from this 1 year warranty.**

A vacuum pad is a consumable part, so it is warranted for a year after it is delivered.

Also, even within the warranty period, the wear of a product due to the use of the vacuum pad or failure due to the deterioration of rubber material are not allowed by the limited warranty.

Compliance Requirements

1. The use of SMC products with production equipment for the manufacture of weapons of mass destruction (WMD) or any other weapon is strictly prohibited.
2. The exports of SMC products or technology from one country to another are governed by the relevant security laws and regulations of the countries involved in the transaction. Prior to the shipment of a SMC product to another country, assure that all local rules governing that export are known and followed.

Safety Instructions

Be sure to read the “Handling Precautions for SMC Products” (M-E03-3) and “Operation Manual” before use.

SMC Corporation