

# Speed Controller with Compact Indicator

New

RoHS

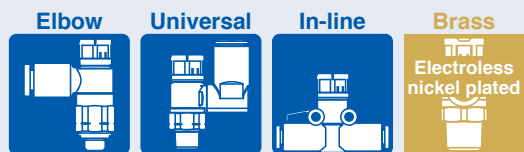

1 to 50 mm/s

AS-FSMA Series

50 to 150 mm/s

AS-FSCA Series

## Reduced Height

Type	Reduction [mm]
Elbow/Universal	5.5
In-line	5.4

Improvement of resolution has made it possible to make fine adjustment.

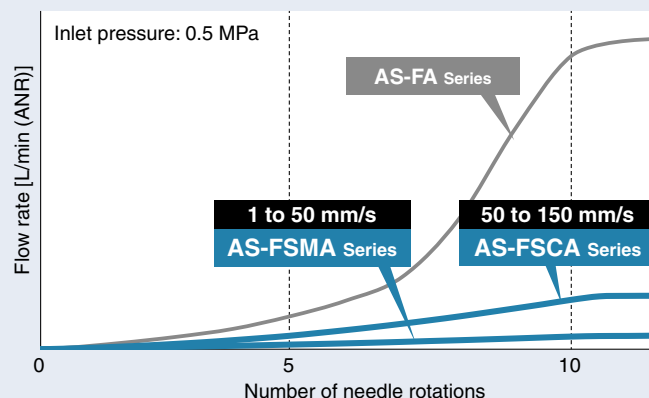

## Better visibility

Check from 360° directions is possible. Inspection and maintenance works are facilitated.



## Flow rate can be controlled numerically with the indicator window.

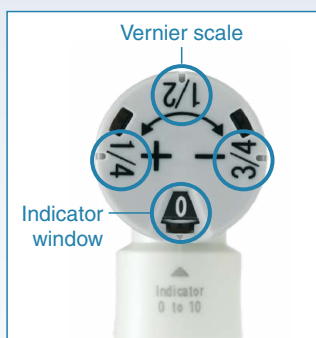

Indicator window	Vernier scale
0	1/4
	1/2
	3/4
⋮	⋮
⋮	⋮
10*1	1/4
	1/2
	3/4

\*1 Body size 1 makes 8 rotations.

■ Due to the vernier indication, it is possible to configure fine settings in 1/4 increments.

- 32 divisions (Body size 1)
- 40 divisions (Body size 2)

■ Reduces work-hours and setting mistakes

\*2 For the elbow type (The number of reference points differs depending on the size. For details, refer to page 20.)



## Series Variations

	With compact indicator	Port size	Applicable tubing O.D.	
			Metric	Inch
Elbow type Universal type	1 to 50 mm/s AS-FSMA Series ▶ p. 1	M5, 10-32UNF	ø2 to ø6	ø1/8" to ø1/4"
	50 to 150 mm/s AS-FSCA Series			
In-line type	1 to 50 mm/s AS□2-FSMA Series ▶ p. 3	—	ø3.2 to ø8	ø1/8" to ø5/16"
	50 to 150 mm/s AS□2-FSCA Series			

AS-FSMA/FSCA Series



CAT.ES20-279A

# Speed Controller with Compact Indicator Elbow Type/Universal Type

1 to 50 mm/s

50 to 150 mm/s

RoHS

# AS-FSMA/FSCA Series

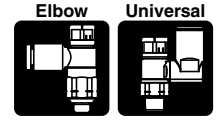

## Model

Model	Port size	Seal method	Applicable tubing O.D.										*3 Max. number of rotations					
			Metric size					Inch size										
			2*2	3.2	4	6	8	10	1/8"	5/32"	1/4"	5/16"		3/8"				
AS1□□1FSM/FSC-M5□□A	M5 x 0.8	Gasket seal	●*4	●	●	●												8
AS1□□1FSM/FSC-U10/32□□A	10-32UNF									●	●	●						
AS2□□1FSM/FSC-□01A	R 1/8	Sealant (R)*1 Face seal (G)		●	●	●	●	●*4										10
AS2□□1FSM/FSC-□02A	G 1/4			●*4	●	●	●	●										
AS2□□1FSM/FSC-□01A	NPT 1/8	Sealant*1									●	●	●	●	●			
AS2□□1FSM/FSC-□02A			NPT 1/4									●*4	●	●	●	●	●	

\*1 "Without sealant" type can be selected as a standard option.

\*2 Only polyurethane tubing is applicable for ø2.

\*3 There are differences in actual rate as by the indicator window over the maximum number of rotations depending on the individual product.

\*4 The universal type is not available.

1 to 50 mm/s

50 to 150 mm/s

Improvement of resolution has made it possible to make fine adjustment.

1 to 50 mm/s

AS-FSMA Series

50 to 150 mm/s

AS-FSCA Series

How to identify the control range

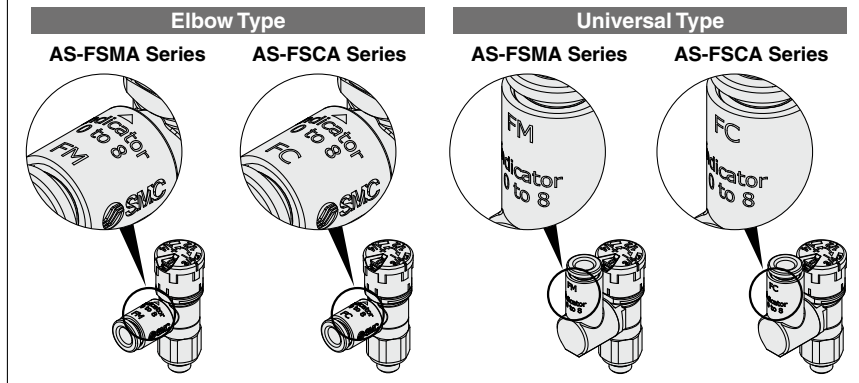

## Specifications

Fluid	Air
Proof pressure	1.5 MPa
Max. operating pressure	1 MPa
Min. operating pressure	0.1 MPa
Ambient and fluid temperatures	-5 to 60°C (No freezing)
Applicable tubing material	Nylon, Soft nylon, Polyurethane*1, FEP, PFA

\*1 Use caution at the max. operating pressure when using soft nylon or polyurethane tubing. (Refer to the [Web Catalog](#) for details.)

## Flow Rate and Sonic Conductance

Model	AS12□1FSM-M5A AS13□1FSM-M5A		AS22□1FSM-□01A AS23□1FSM-□01A		AS22□1FSM-□02A AS23□1FSM-□02A		AS12□1FSC-M5A AS13□1FSC-M5A		AS22□1FSC-□01A AS23□1FSC-□01A		AS22□1FSC-□02A AS23□1FSC-□02A								
	Metric size	ø2	ø3.2	ø4	ø6	ø8	ø10	ø2	ø3.2	ø4	ø6	ø8	ø10						
Tubing O.D.	Metric size	ø2	ø3.2	ø4	ø6	ø8	ø10	ø2	ø3.2	ø4	ø6	ø8	ø10						
	Inch size	—	ø1/8" ø5/32" ø1/4"	ø1/8"	5/32"	ø1/4" ø5/16"	ø1/8"	5/32"	—	ø1/8" ø5/32" ø1/4"	ø1/8"	5/32"	ø1/4" ø5/16" ø3/8"						
C values: Sonic conductance dm <sup>3</sup> /(s·bar)	Free flow	0.2	0.3	0.4	0.6	0.6	0.7	1.0	1.3	1.5	0.2	0.3	0.4	0.6	0.6	0.7	1.0	1.3	1.5
	Controlled flow	0.01		0.03		0.1		0.05		0.1		0.3							
b values: Critical pressure ratio	Free flow	0.3	0.4	0.2	0.3	0.3	0.4	0.3	0.4	0.2	0.3	0.3	0.4						
	Controlled flow	0.3		0.3		0.3		0.2		0.3		0.3							

\* 10-32UNF has the same specification as M5.

\* C and b values are for controlled flow with the needle fully open and free flow with the needle fully closed.

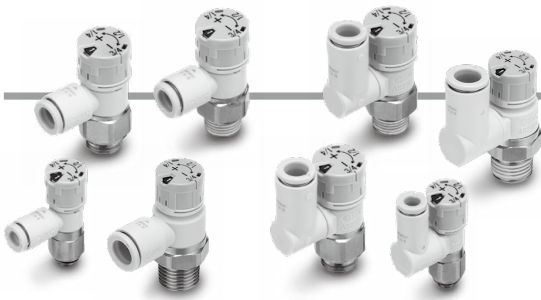
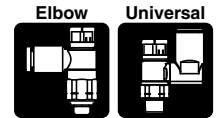

**How to Order**

• **Applicable tubing O.D.\*1**

Metric size		Inch size	
02	ø2	01	ø1/8"
23	ø3.2*2	03	ø5/32"
04	ø4	07	ø1/4"
06	ø6		

\*1 For selecting applicable tubing O.D., refer to the "Model" on page 1. Metric size and inch size types can be visually identified by the color of the release button.  
Metric size: Light gray  
Inch size: Orange

\*2 Use ø1/8" tubing.

• **Width across flats (H)**

E	8 mm
Nil	9 mm

• **Body size**

1	M5 x 0.8 10-32UNF
---	----------------------

• **Port size**

M5	M5 x 0.8
U10/32	10-32UNF

**Body Size 1**

**AS 1 2 0 1 FSM - M5 E - 06 A -**

**Body Size 2**

**AS 2 2 0 1 FSM - 01 - 06 S A -**

• **Body size**

2	1/8, 1/4
---	----------

• **Type**

2	Elbow
3	Universal

• **Control type\*1**

0	Meter-out
1	Meter-in

\*1 Meter-out and meter-in types can be visually identified by the color of the knob.  
Meter-out: Gray  
Meter-in: Light blue

• **Control range**

FSM	1 to 50 mm/s
FSC	50 to 150 mm/s

• **Thread type**

Nil	R
N	NPT
G	G

• **Port size**

01	1/8
02	1/4

• **Made to order**  
Refer to page 17 for details.

• **With compact indicator**

• **Seal method**

Nil	Without sealant
S	With sealant

\* Face seal type is used for the G thread type. Select "Nil/Without sealant."  
Example) AS2201FSM-G01-06

• **Applicable tubing O.D.\*1**

Metric size		Inch size*3	
23	ø3.2*2	01	ø1/8"
04	ø4	03	ø5/32"
06	ø6	07	ø1/4"
08	ø8	09	ø5/16"
10	ø10	11	ø3/8"

\*1 For selecting applicable tubing O.D., refer to the "Model" on page 1.

\*2 Use ø1/8" tubing.

\*3 Only the metric size is available for the G thread type.

**Flow Direction Symbols on Body**

	Meter-out	Meter-in
Symbol		



**Made to Order**  
(For details, refer to page 17.)

Symbol	Specifications
-X12	Lubricant: Vaseline
-X21	Grease-free (Seal: Fluorine-coated) + Restrictor (Without check valve)
-X214	Restrictor (Without check valve)
10-	Clean series

**Caution**

Be sure to read this before handling the products. Refer to the back cover for safety instructions. For flow control equipment precautions, refer to the "Handling Precautions for SMC Products" and the "Operation Manual" on the SMC website. For specific product precautions, refer to the catalogs for the Push-lock Type Speed Controller with One-touch Fitting and the Speed Controller with Indicator on the website.

# Speed Controller with Compact Indicator In-line Type

1 to 50 mm/s

50 to 150 mm/s

RoHS

# AS-FSMA/FSCA Series

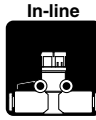

## Model

Model	Applicable tubing O.D.							
	Metric size				Inch size			
	3.2	4	6	8	1/8"	5/32"	1/4"	5/16"
AS1002FSM/FSC□A	●	●	●		●	●	●	
AS2002FSM/FSC□A		●	●			●	●	
AS2052FSM/FSC□A			●	●			●	●

1 to 50 mm/s

50 to 150 mm/s

Improvement of resolution has made it possible to make fine adjustment.

1 to 50 mm/s

AS-FSMA Series

50 to 150 mm/s

AS-FSCA Series

How to identify the control range

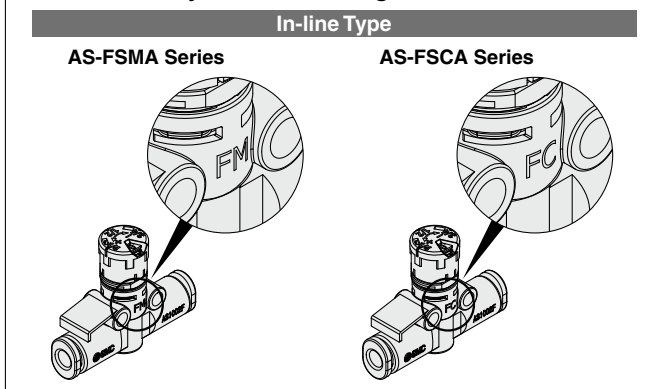

## Specifications

Fluid	Air
Proof pressure	1.5 MPa
Max. operating pressure	1 MPa
Min. operating pressure	0.1 MPa
Ambient and fluid temperatures	-5 to 60°C (No freezing)
Applicable tubing material	Nylon, Soft nylon, Polyurethane*1, FEP, PFA

\*1 Use caution at the max. operating pressure when using soft nylon or polyurethane tubing.  
(Refer to the **Web Catalog** for details.)

## Flow Rate and Sonic Conductance

Model		AS1002FSM-□A			AS2002FSM-□A		AS2052FSM-□A		AS1002FSC-□A			AS2002FSC-□A		AS2052FSC-□A	
Tubing O.D.	Metric size	ø3.2	ø4	ø6	ø4	ø6	ø6	ø8	ø3.2	ø4	ø6	ø4	ø6	ø6	ø8
	Inch size	ø1/8"	5/32"	ø1/4"	5/32"	ø1/4"	ø1/4"	ø5/16"	ø1/8"	5/32"	ø1/4"	5/32"	ø1/4"	ø1/4"	ø5/16"
C values: Sonic conductance dm <sup>3</sup> /(s·bar)	Free flow	0.3	0.4	0.6	0.4	0.6	1.0	1.2	0.3	0.4	0.6	0.4	0.6	1.0	1.2
	Controlled flow	0.01			0.03		0.1		0.05			0.1		0.3	
b values: Critical pressure ratio	Free flow	0.3	0.2		0.3	0.1	0.2		0.3	0.2		0.3	0.1	0.2	
	Controlled flow	0.4			0.3		0.3		0.3			0.4		0.4	

\* C and b values are for controlled flow with the needle fully open and free flow with the needle fully closed.

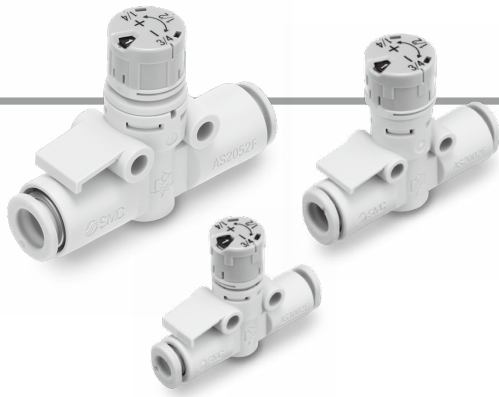

**How to Order**

**AS 200 2 FSM - 06 A -**

**Body size**

<b>100</b>	M5 standard
<b>200</b>	1/8 standard
<b>205</b>	1/4 standard

**Control range**

<b>FSM</b>	1 to 50 mm/s
<b>FSC</b>	50 to 150 mm/s

• Made to order

• With compact indicator

**Applicable tubing O.D.\*1**

Metric size		Inch size	
<b>23</b>	ø3.2*2	<b>01</b>	ø1/8"
<b>04</b>	ø4	<b>03</b>	ø5/32"
<b>06</b>	ø6	<b>07</b>	ø1/4"
<b>08</b>	ø8	<b>09</b>	ø5/16"

\*1 For selecting applicable tubing O.D., refer to the "Model" on page 3.

\*2 Use ø1/8" tubing.

**Flow Direction Symbol on Body**

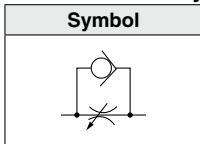

**Made to Order**  
(For details, refer to page 17.)

Symbol	Specifications
<b>-X12</b>	Lubricant: Vaseline
<b>-X21</b>	Grease-free (Seal: Fluorine-coated) + Restrictor (Without check valve)
<b>-X214</b>	Restrictor (Without check valve)
<b>10-</b>	Clean series

**⚠ Caution**

Be sure to read this before handling the products. Refer to the back cover for safety instructions. For flow control equipment precautions, refer to the "Handling Precautions for SMC Products" and the "Operation Manual" on the SMC website. For specific product precautions, refer to the catalogs for the Push-lock Type Speed Controller with One-touch Fitting and the Speed Controller with Indicator on the website.

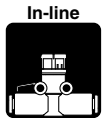

**Options: In-line Type**

**① Adapter for Direct Mounting**

\* For use when the mounting surface interferes with the bonnet

Part no.	Applicable model
<b>AS-10A1</b>	AS1002FSM/FSC□A
<b>AS-20A1</b>	AS2002FSM/FSC□A

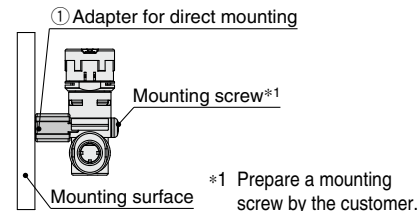

**② DIN Rail Mounting Bracket**

Part no.	Applicable model
<b>AS-10D</b>	AS1002FSM/FSC□A
<b>AS-20D</b>	AS2002FSM/FSC□A
<b>AS-25D</b>	AS2052FSM/FSC□A

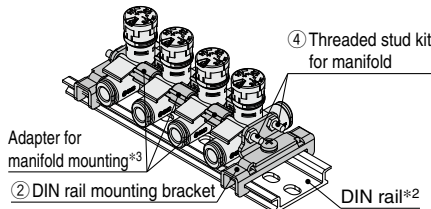

\*2 Prepare a DIN rail by the customer.

\*3 It is included in the threaded stud kit for manifold. Refer to the following details of the kit.

**③ L-Bracket**

Part no.	Applicable model
<b>AS-10L</b>	AS1002FSM/FSC□A
<b>AS-20L</b>	AS2002FSM/FSC□A
<b>AS-25L</b>	AS2052FSM/FSC□A

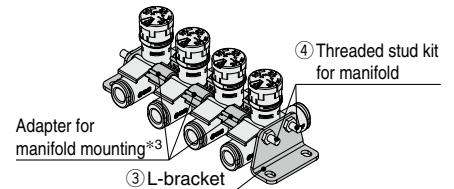

\* The AS2052FSM/FSC□A can be mounted without the adapter.

**④ Threaded Stud Kit for Manifold**

Part no.				Applicable model	
4 stations	6 stations	8 stations	10 stations	Metric size	Inch size
<b>AS-1AB</b>	<b>AS-3AB</b>	<b>AS-5AB</b>	<b>AS-7AB</b>	AS1002FSM/FSC□-23A	AS1002FSM/FSC□-01A
				AS1002FSM/FSC□-04A	AS1002FSM/FSC□-03A
<b>AS-2AB</b>	<b>AS-4AB</b>	<b>AS-6AB</b>	<b>AS-8AB</b>	AS1002FSM/FSC□-06A	—
				AS1002FSM/FSC□-07A	—
<b>AS-9AB</b>	<b>AS-10AB</b>	<b>AS-11AB</b>	<b>AS-12AB</b>	AS2002FSM/FSC□-04A	AS2002FSM/FSC□-03A
				AS2002FSM/FSC□-06A	—
				—	AS2002FSM/FSC□-07A
<b>AS-41B</b>	<b>AS-42B</b>	<b>AS-44B</b>	<b>AS-45B</b>	AS2052FSM/FSC□-06A	—
				—	AS2052FSM/FSC□-07A
				AS2052FSM/FSC□-08A	AS2052FSM/FSC□-09A

\* The AS2052FSM/FSC□A can be mounted with the threaded stud kit only.

**Details of Threaded Stud Kit for Manifold**

Part no.	Adapter for manifold mounting		Threaded stud		Accessories				
	Part no.	Qty.	Length	Qty.	Hexagon nut	Qty.	Flat washer	Qty.	
<b>AS-1AB</b>	AS-10A	3	72	2	M3	4	M3	4	
<b>AS-2AB</b>			90	2					
<b>AS-3AB</b>			5	104					2
<b>AS-4AB</b>		114		2					
<b>AS-5AB</b>		7		135					2
<b>AS-6AB</b>			143	2					
<b>AS-7AB</b>			9	167					2
<b>AS-8AB</b>		170		2					
<b>AS-23AB</b>		180		2					
<b>AS-9AB</b>	AS-20A	3	90	2	M4	4	M4	4	
<b>AS-10AB</b>			5	135					2
<b>AS-11AB</b>			7	180					2
<b>AS-12AB</b>			9	220					2
<b>AS-41B</b>	—	—	78	2	M4	4	M4	4	
<b>AS-42B</b>			111	2					
<b>AS-43B</b>			119	2					
<b>AS-44B</b>			147	2					
<b>AS-45B</b>			179	2					

**Ordering Example**

Threaded studs for manifold are not included when L-bracket and DIN rail mounting bracket are ordered. Please order them according to the number of stations.

**Ex.) AS2002FSM-06A**

When connecting 4 pcs. and mounting L-brackets on both sides

- Speed controller **AS2002FSM-06A** ..... 4 pcs.
- L-bracket **AS-20L** ..... 2 pcs.
- Threaded stud kit for manifold **AS-9AB** ..... 1 set (Adapter for manifold mounting is included.)

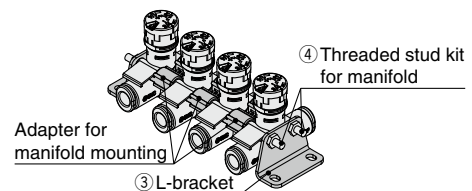

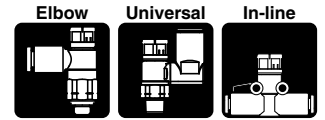

**Needle Valve: Flow Rate Characteristics**

**1 to 50 mm/s**

AS1002FSM-□A  
AS1201FSM-M5□A, AS1211FSM-M5□A  
AS1301FSM-M5□A, AS1311FSM-M5□A

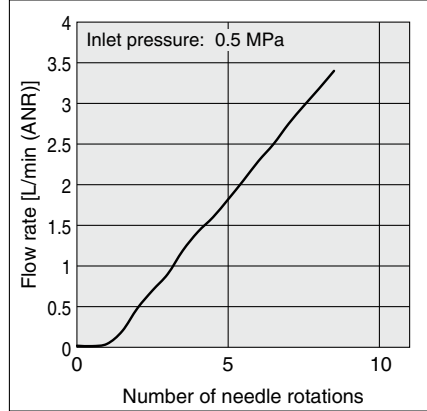

\* -U10/32 has the same specification as M5.

AS2002FSM-□A  
AS2201FSM-01A, AS2211FSM-01A  
AS2301FSM-01A, AS2311FSM-01A

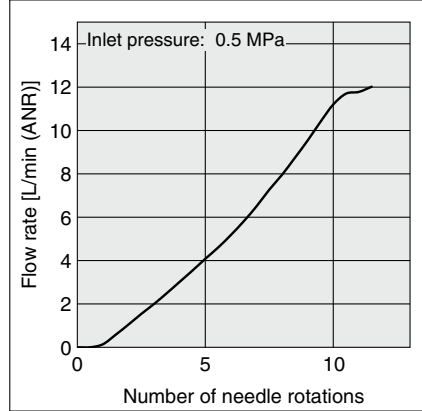

AS2201FSM-02A, AS2211FSM-02A  
AS2301FSM-02A, AS2311FSM-02A  
AS2052FSM-□-□A

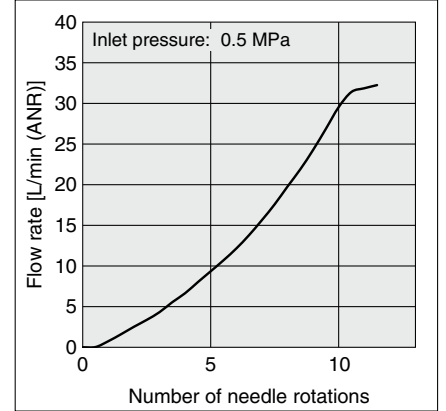

**50 to 150 mm/s**

AS1002FSC-□A  
AS1201FSC-M5□A, AS1211FSC-M5□A  
AS1301FSC-M5□A, AS1311FSC-M5□A

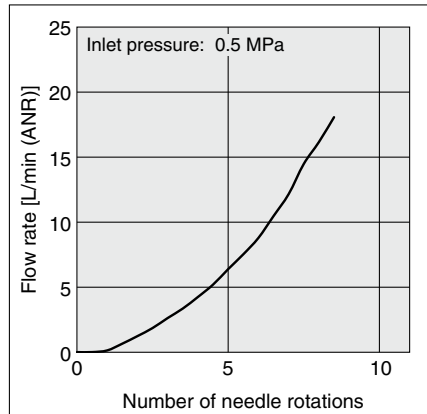

AS2002FSC-□A  
AS2201FSC-01A, AS2211FSC-01A  
AS2301FSC-01A, AS2311FSC-01A

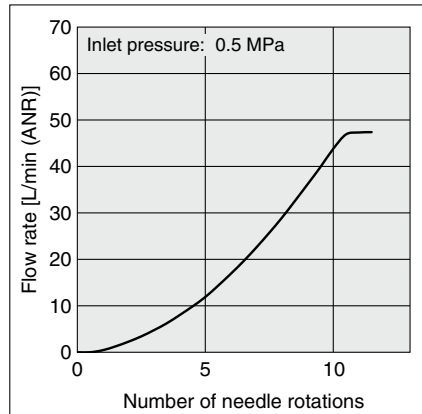

AS2201FSC-02A, AS2211FSC-02A  
AS2301FSC-02A, AS2311FSC-02A  
AS2052FSC-□-□A

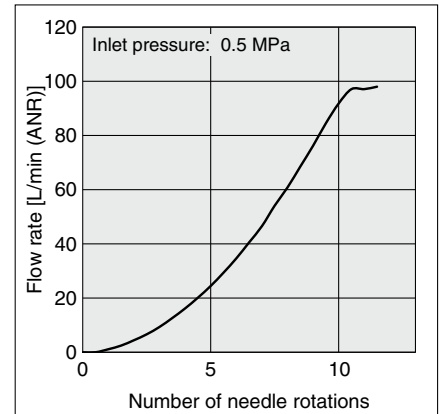

1 to 50 mm/s 50 to 150 mm/s  
**AS-FSMA/FSCA Series**

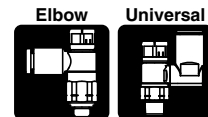

**Construction**

**Elbow Type**

Seal method: Gasket seal  
 For M5, 10-32UNF

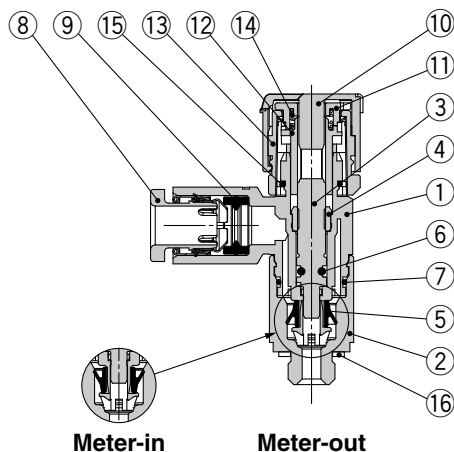

Seal method: Sealant, Face seal  
 For R, NPT, G thread

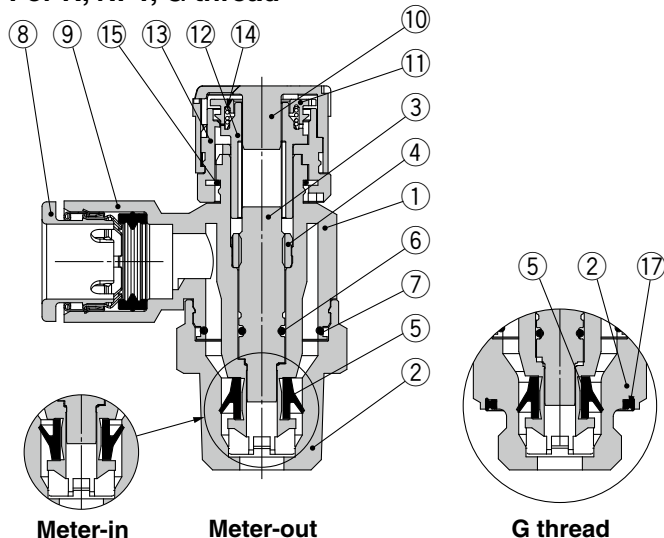

**Universal Type**

Seal method: Gasket seal  
 For M5, 10-32UNF

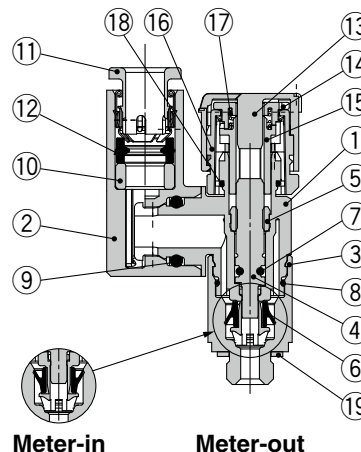

Seal method: Sealant, Face seal  
 For R, NPT, G thread

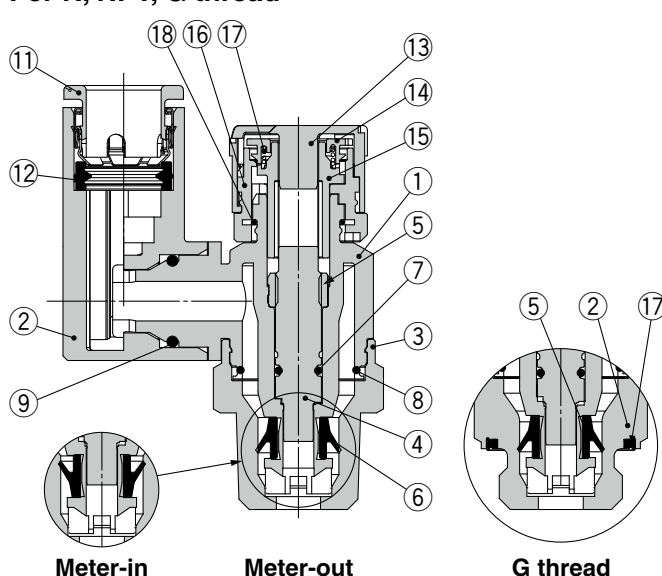

**Component Parts**

No.	Description	Material	Note
1	Body A	PBT	
2	Body B	Brass	Electroless nickel plating
3	Needle	PBT	
4	Needle guide	Brass	Electroless nickel plating
5	U-seal	HNBR	
6	O-ring	NBR	
7	O-ring	NBR	
8	Cassette	—	
9	Seal	NBR	
10	Knob	POM	
11	Indicator gear	POM	
12	Shaft	POM	
13	Spacer	PBT	
14	Spring	Stainless steel	
15	Clip	Stainless steel	
16	Gasket	NBR/Stainless steel	
17	Seal	NBR	

**Component Parts**

No.	Description	Material	Note
1	Body A	PBT	
2	Elbow body	PBT	
3	Body B	Brass	Electroless nickel plating
4	Needle	PBT	
5	Needle guide	Brass	Electroless nickel plating
6	U-seal	HNBR	
7	O-ring	NBR	
8	O-ring	NBR	
9	O-ring	NBR	
10	Spacer	PBT	Only for ø3.2, ø1/8", ø4, and ø5/32"
11	Cassette	—	
12	Seal	NBR	
13	Knob	POM	
14	Indicator gear	POM	
15	Shaft	POM	
16	Spacer	PBT	
17	Spring	Stainless steel	
18	Clip	Stainless steel	
19	Gasket	NBR/Stainless steel	
20	Seal	NBR	





## Construction

### In-line Type

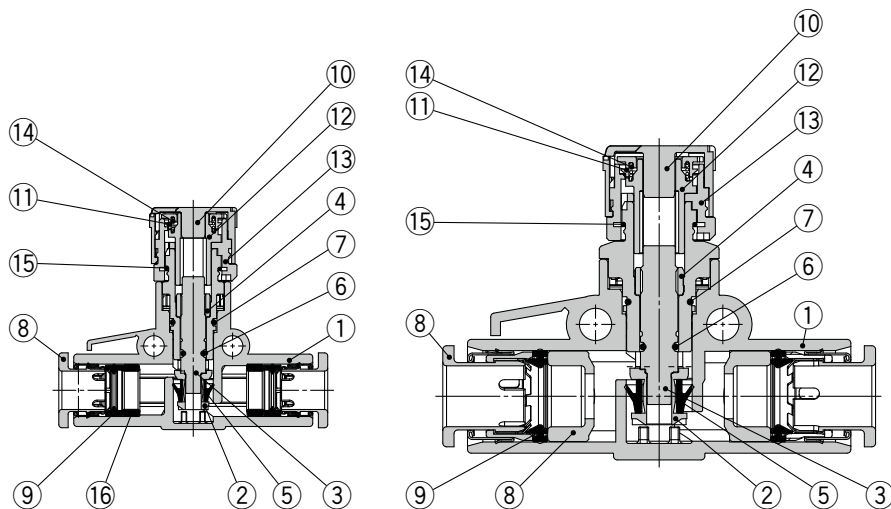

#### Component Parts

No.	Description	Material	Note
1	Body A	PBT	
2	Body B	PBT	
3	Needle	PBT	
4	Needle guide	Brass	Electroless nickel plating
5	U-seal	HNBR	
6	O-ring	NBR	
7	O-ring	NBR	
8	Cassette	—	
9	Seal	NBR	
10	Knob	POM	
11	Indicator gear	POM	
12	Shaft	POM	
13	Spacer	PBT	
14	Spring	Stainless steel	
15	Clip	Stainless steel	
16	Spacer*1	PBT	

\*1 AS1002FS□-23A, AS1002FS□-01A, AS1002FS□-07A, and AS2002FS□-07A are not equipped with a spacer.

#### L-Bracket

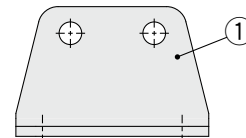

#### Component Parts

No.	Description	Material
1	Bracket	Steel strip

#### DIN Rail Mounting Bracket

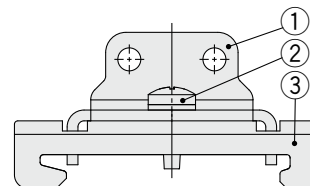

#### Component Parts

No.	Description	Material
1	Bracket	Steel strip
2	Cross recessed round head screw	Steel strip
3	Clasp	Steel strip

1 to 50 mm/s 50 to 150 mm/s  
**AS-FSMA/FSCA Series**

**Dimensions: Elbow Type**

Seal method: Gasket seal  
 For M5, 10-32UNF

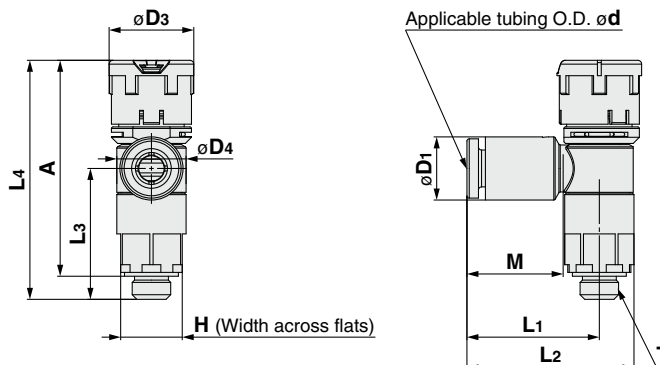

**Metric Size**

Model	d	T	H	D1	D3	D4	L1	L2	L3	L4*1		A*2		M	Weight [g]	
										Unlocked	Locked	Unlocked	Locked			
AS12□1FSM/FSC-M5E-02A	2	M5 x 0.8 10/32UNF	8 (9)	5.8	11	9	15.8	20.6	16.9	32.1	31.0	29.1	28.0	11.9	6	
AS12□1FSM/FSC-M5E-23A	3.2			7.2			17.2	22						13		
AS12□1FSM/FSC-M5E-04A	4			8.2			18.6	23.4						16.5		7
AS12□1FSM/FSC-M5E-06A	6			10.4												

- \*1 Reference dimensions
- \*2 Reference dimensions of threads after installation
- \* The value in ( ) indicates that the dimension for the width across flats is 9 mm.

**Inch Size**

Model	d	T	H	D1	D3	D4	L1	L2	L3	L4*1		A*2		M	Weight [g]	
										Unlocked	Locked	Unlocked	Locked			
AS12□1FSM/FSC-U10/32E-01A	1/8"	M5 x 0.8 10/32UNF	8 (9)	7.2	11	9	17.2	22	16.9	32.1	31.0	29.1	28.0	13	6	
AS12□1FSM/FSC-U10/32E-03A	5/32"			8.2			18.6	23.4						16.5		7
AS12□1FSM/FSC-U10/32E-07A	1/4"			11.2												

- \*1 Reference dimensions
- \*2 Reference dimensions of threads after installation
- \* The value in ( ) indicates that the dimension for the width across flats is 9 mm.



**Dimensions: Universal Type**

Seal method: Gasket seal  
For M5, 10-32UNF

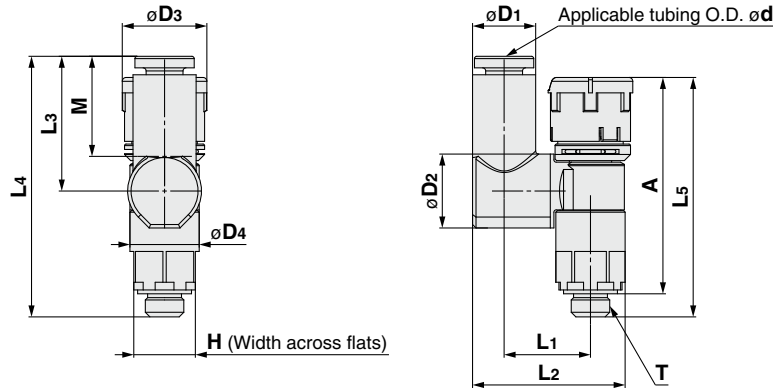

**Metric Size**

Model	d	T	H	D1	D2	D3	D4	L1	L2	L3	L4	L5*1		A*2		M	Weight [g]			
												Unlocked	Locked	Unlocked	Locked					
AS13□1FSM/FSC-M5E-23A	3.2	M5 x 0.8 10/32UNF	8 (9)	7.2	9.6	11	9	11.6	19.4	17.5	33.8	32.2	31.1	29.1	28.0	13	6			
AS13□1FSM/FSC-M5E-04A	4			8.2				11.5	19.8									20.9	20.4	36.6
AS13□1FSM/FSC-M5E-06A	6			10.4																

\*1 Reference dimensions  
\*2 Reference dimensions of threads after installation  
\* The value in ( ) indicates that the dimension for the width across flats is 9 mm.

**Inch Size**

Model	d	T	H	D1	D2	D3	D4	L1	L2	L3	L4	L5*1		A*2		M	Weight [g]			
												Unlocked	Locked	Unlocked	Locked					
AS13□1FSM/FSC-U10/32E-01A	1/8	M5 x 0.8 10/32UNF	8 (9)	7.2	9.6	11	9	11.6	19.4	17.5	33.8	32.2	31.1	29.1	28.0	13	6			
AS13□1FSM/FSC-U10/32E-03A	5/32			8.2				11.5	19.8									21.3	20.4	36.6
AS13□1FSM/FSC-U10/32E-07A	1/4			11.2																

\*1 Reference dimensions  
\*2 Reference dimensions of threads after installation  
\* The value in ( ) indicates that the dimension for the width across flats is 9 mm.

1 to 50 mm/s      50 to 150 mm/s

# AS-FSMA/FSCA Series

## Dimensions: Elbow Type

Seal method: Sealant  
For R, NPT thread

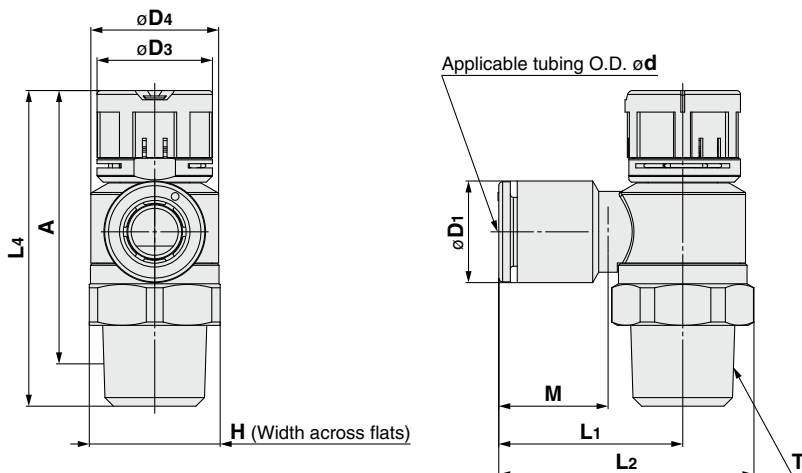

### Metric Size

Model	d	T	H	D1	D3	D4	L1	L2	L3	L4*1		A*2		M	Weight [g]
										Unlocked	Locked	Unlocked	Locked		
AS22□1FSM/FSC-01-23(S)A	3.2	1/8	12.7	7.2	14	12.6	19.1	26.1 (26)	19.1	36.6	35.1	33.5	32.0	13	11 (11)
AS22□1FSM/FSC-01-04(S)A	4			12 (13)											
AS22□1FSM/FSC-01-06(S)A	6			13 (14)											
AS22□1FSM/FSC-01-08(S)A	8			14 (15)											
AS22□1FSM/FSC-01-10(S)A	10			15.6											
AS22□1FSM/FSC-02-23(S)A	3.2	1/4	17	7.2	13	16.6	20.9	30.2	22.6	49.7	48.3	44.2	42.8	13.3	23
AS22□1FSM/FSC-02-04(S)A	4			24											
AS22□1FSM/FSC-02-06(S)A	6			24											
AS22□1FSM/FSC-02-08(S)A	8			14.2											
AS22□1FSM/FSC-02-10(S)A	10			15.6											

\*1 Reference dimensions

\*2 Reference dimensions of threads after installation

### Inch Size

Model	d	T	H	D1	D3	D4	L1	L2	L3	L4*1		A*2		M	Weight [g]
										Unlocked	Locked	Unlocked	Locked		
AS22□1FSM/FSC-N01-01(S)A	1/8"	1/8	12.7	7.2	14	12.6	19.1	26.1 (26)	19.1	36.4	34.9	33.3	31.8	13	11 (11)
AS22□1FSM/FSC-N01-03(S)A	5/32"			12 (11)											
AS22□1FSM/FSC-N01-07(S)A	1/4"			13 (12)											
AS22□1FSM/FSC-N01-09(S)A	5/16"			14.2											
AS22□1FSM/FSC-N02-01(S)A	1/8"	1/4	17.5	7.2	13	16.6	20.9	30.3	22.6	49.7	48.3	44.2	42.8	13.3	24
AS22□1FSM/FSC-N02-03(S)A	5/32"			24											
AS22□1FSM/FSC-N02-07(S)A	1/4"			24											
AS22□1FSM/FSC-N02-09(S)A	5/16"			14.2											
AS22□1FSM/FSC-N02-11(S)A	3/8"			15.6											

\*1 Reference dimensions

\*2 Reference dimensions of threads after installation



**Dimensions: Elbow Type**

Seal method: Face seal  
For G thread

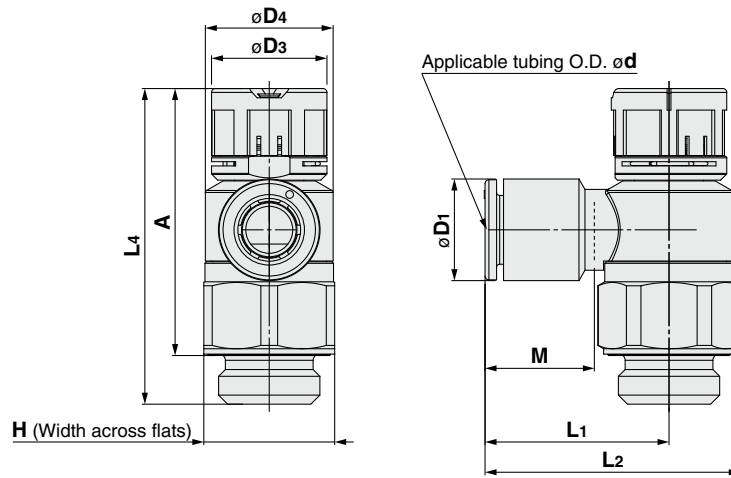

**Metric Size**

Model	d	T	H	D1	D3	D4	L1	L2	L3	L4*1		A*2		M	Weight [g]	
										Unlocked	Locked	Unlocked	Locked			
AS22□1FSM/FSC-G01-23A	3.2	1/8	13	7.2	14	12.6	19.1	26.1	18.8	36.6	35.1	31.1	29.6	13	12	
AS22□1FSM/FSC-G01-04A	4			8.2											12	
AS22□1FSM/FSC-G01-06A	6			10.4											12	
AS22□1FSM/FSC-G01-08A	8			13.2											14.2	13
AS22□1FSM/FSC-G01-10A	10			15.9											15.6	14
AS22□1FSM/FSC-G02-23A	3.2	1/4	17	7.2	13	16.6	20.9	30.2	22.6	49.7	48.3	43.2	41.8	13.3	26	
AS22□1FSM/FSC-G02-04A	4			8.2											26	
AS22□1FSM/FSC-G02-06A	6			10.4											14.2	27
AS22□1FSM/FSC-G02-08A	8			13.2											15.6	28
AS22□1FSM/FSC-G02-10A	10			15.9												

\*1 Reference dimensions

\*2 Reference dimensions of threads after installation

1 to 50 mm/s      50 to 150 mm/s

# AS-FSMA/FSCA Series



Dimensions: **Universal Type**

Seal method: Sealant  
For R, NPT thread

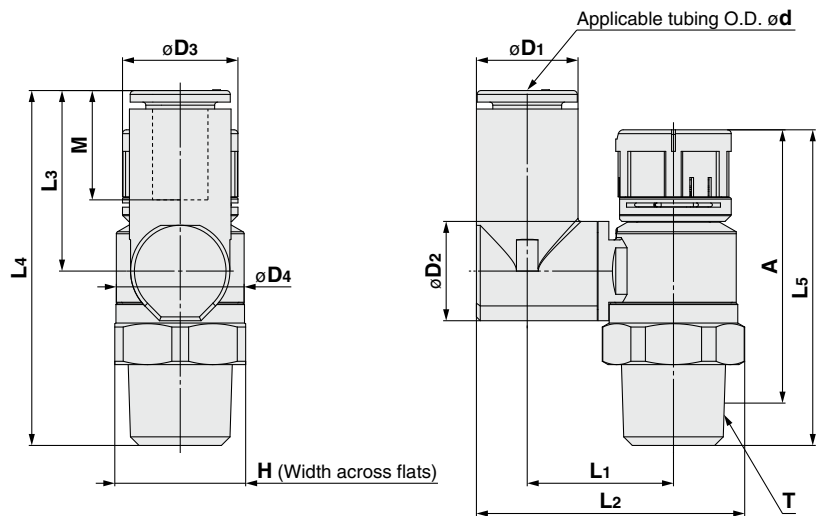

## Metric Size

Model	d	T	H	D1	D2	D3	D4	L1	L2	L3	L4	L5*1		A*2		M	Weight [g]			
												Unlocked	Locked	Unlocked	Locked					
AS23□1FSM/FSC-01-23(S)A	3.2	1/8	13 (12.7)	7.2	9.6	14	12.6	13.3	24	17.5	36	36.6	35.1	33.5	32.0	13	10 (10)			
AS23□1FSM/FSC-01-04(S)A	4			8.2				13.9	25.1											
AS23□1FSM/FSC-01-06(S)A	6			10.4				26.2	20.4									38.8		
AS23□1FSM/FSC-01-08(S)A	8			13.2				10.2	16.4									30.1	21.5	40
AS23□1FSM/FSC-02-04(S)A	4	1/4	17	8.2	12.9	13	16.6	16.5	29.9	17.5	40.1	49.7	48.3	44.2	42.8	13.3	24			
AS23□1FSM/FSC-02-06(S)A	6			11.2				19	33.8									21.4	43.9	
AS23□1FSM/FSC-02-08(S)A	8			13.2				34.9	23.5									46	15.6	27
AS23□1FSM/FSC-02-10(S)A	10			15.9				20.9	38.1									24.7	47.3	17

\*1 Reference dimensions  
\*2 Reference dimensions of threads after installation  
\* The values in ( ) are for NPT thread.

## Inch Size

Model	d	T	H	D1	D2	D3	D4	L1	L2	L3	L4	L5*1		A*2		M	Weight [g]			
												Unlocked	Locked	Unlocked	Locked					
AS22□1FSM/FSC-N01-01(S)A	1/8"	1/8	13 (12.7)	7.2	9.6	14	12.6	13.3	24	17.5	36	36.6	35.1	33.5	32.0	13	10 (10)			
AS22□1FSM/FSC-N01-03(S)A	5/32"			8.2				13.9	25.1											
AS22□1FSM/FSC-N01-07(S)A	1/4"			10.4				26.2	20.4									38.8		
AS22□1FSM/FSC-N01-09(S)A	5/16"			13.2				10.2	16.4									30.1	21.5	40
AS23□1FSM/FSC-N02-03(S)A	5/32	1/4	17.5	8.2	12.9	13	16.6	16.5	29.9	17.5	40.1	49.7	48.3	44.2	42.8	13.3	24			
AS23□1FSM/FSC-N02-07(S)A	1/4			11.2				19	33.8									21.4	43.9	
AS23□1FSM/FSC-N02-09(S)A	5/16			13.2				34.9	23.5									46	14.2	27
AS23□1FSM/FSC-N02-11(S)A	3/8			15.9				20.9	38.1									24.7	47.3	15.6

\*1 Reference dimensions  
\*2 Reference dimensions of threads after installation  
\* The values in ( ) are for NPT thread.



**Dimensions: Universal Type**

Seal method: Face seal  
For G thread

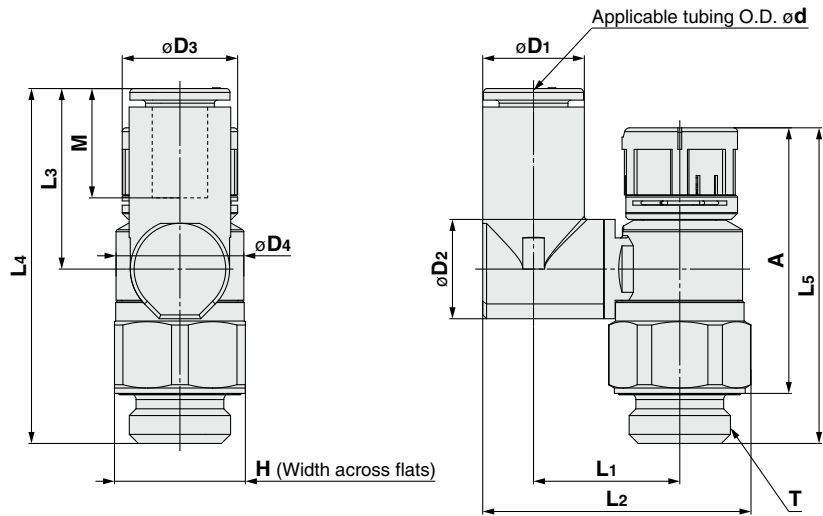

**Metric Size**

Model	d	T	H	D1	D2	D3	D4	L1	L2	L3	L4	L5*1		A*2		M	Weight [g]		
												Unlocked	Locked	Unlocked	Locked				
AS23□1FSM/FSC-G01-23A	3.2	1/8	13	7.2	9.6	14	12.6	13.2	24	17.5	35.7	36.6	35.1	31.1	29.6	13	12		
AS23□1FSM/FSC-G01-04A	4			8.2				13.9	25.1										
AS23□1FSM/FSC-G01-06A	6			10.4				26.2	20.4									38.5	
AS23□1FSM/FSC-G01-08A	8			13.2				10.2	16.4									30.1	21.5
AS23□1FSM/FSC-G02-04A	4	1/4	17	8.2	12.9	13	16.6	16.5	29.9	17.5	40.1	49.7	48.3	43.2	41.8	13.3	26		
AS23□1FSM/FSC-G02-06A	6			10.4				19	33.8								21.4	43.9	28
AS23□1FSM/FSC-G02-08A	8			13.2				19	34.9								23.5	46	29
AS23□1FSM/FSC-G02-10A	10			15.9				20.9	38.1								24.7	47.3	32

\*1 Reference dimensions

\*2 Reference dimensions of threads after installation

1 to 50 mm/s 50 to 150 mm/s  
**AS-FSMA/FSCA Series**

Dimensions: **In-line Type**

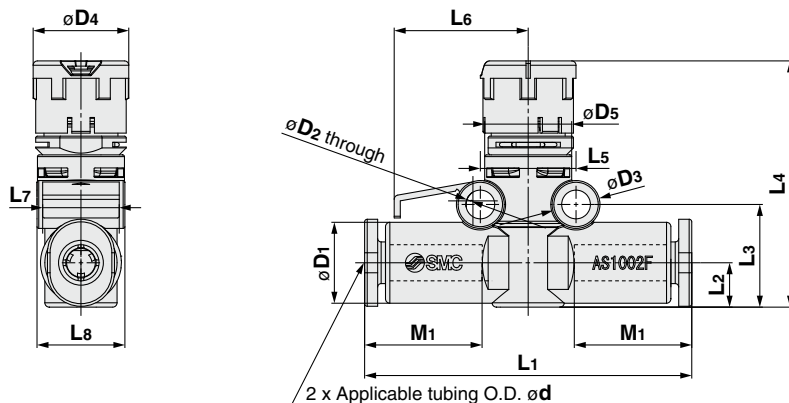

Front view

Right side view

Release button dimensions

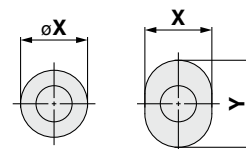

Applicable tubing O.D.: ø3.2, ø4, ø6, ø1/8", ø5/32"

Metric Size

[mm]

Model	Applicable tubing O.D. ød	D1	Release button		D2	D3	D4	D5	L1	L2	L3	L4*1		L5	L6	L7	L8	M1	Weight [g]		
			øX (X)	Y								Max.	Min.								
AS1002FSM/FSC-23A	3.2	8.4	6.7	9.5	3.3	5.5	11	10	36.6	5.1	11.8	29.6	28.5	11	15.4	8.8	10.1	13.5	4.4		
AS1002FSM/FSC-04A	4	9.3	7.7	10	3.3	5.5		10	37.6											13	4.7
AS1002FSM/FSC-06A	6	11.6	9.7	12	3.3	5.5		10	40.1											6.1	12.8
AS2002FSM/FSC-04A	4	9.3	7.7	10	3.3	5.5	14	12	41.3	6.3	13.4	37.2	35.7	12.6	17	10.5	12.3	13	6.9		
AS2002FSM/FSC-06A	6	11.6	9.7	12	3.3	5.5		12	43.1											7.8	7.8
AS2052FSM/FSC-06A	6	12.8	11.5	—	4.3	7.8	13	16	54.2	7.6	17.2	49.0	47.6	17	22.5	12	16.1	17	16		
AS2052FSM/FSC-08A	8	15.2	13.5	—					57.2	8.5	18.1	49.9	48.5							19	18.4

\*1 Reference dimensions

Inch Size

[mm]

Model	Applicable tubing O.D. ød	D1	Release button		D2	D3	D4	D5	L1	L2	L3	L4*1		L5	L6	L7	L8	M1	Weight [g]		
			øX (X)	Y								Max.	Min.								
AS1002FSM/FSC-01A	1/8"	8.4	6.7	9.5	3.3	5.5	11	10	36.6	5.1	11.8	29.6	28.5	11	15.4	8.8	10.1	13.5	4.4		
AS1002FSM/FSC-03A	5/32"	9.3	7.7	10					37.6											13	4.7
AS1002FSM/FSC-07A	1/4"	12	10.9	—					40.1											6.2	12.9
AS2002FSM/FSC-03A	5/32"	9.3	7.7	10	3.3	5.5	14	12	41.3	6.3	13.4	37.2	35.7	12.6	17	10.5	12.3	13	6.9		
AS2002FSM/FSC-07A	1/4"	12	10.9	—					43.2											6.5	13.6
AS2052FSM/FSC-07A	1/4"	13.2	12	—	4.3	7.8	13	16	53.4	7.6	17.2	49	47.6	17	22.5	12	16.1	17	16.4		
AS2052FSM/FSC-09A	5/16"	15.2	13.5	—					57.2											8.5	18.1

\*1 Reference dimensions





**Dimensions: In-line Type**

**L-Bracket**

Bracket on a single side

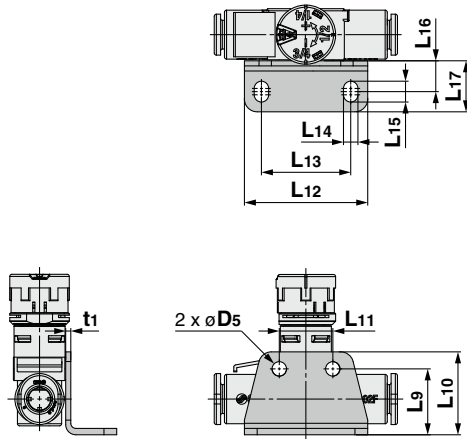

Part no.	Applicable model	D5	L9	L10	L11	L12	L13	L14	L15	L16	L17	t1
AS-10L	AS1002FSM/FSC□A	3.4	14.8	18.3	11	27.5	19.5	3.4	4.9	7.3	12	1
AS-20L	AS2002FSM/FSC□A		15.6	19.6	12.6	29	21					
AS-25L	AS2052FSM/FSC□A	4.5	19.6	24.6	17	38	28	4.5	6.5	9.5	15.5	1.2

**DIN Rail Mounting Bracket**

Bracket on a single side

AS1002FSM/FSC□A  
AS2002FSM/FSC□A  
AS2052FSM/FSC□A

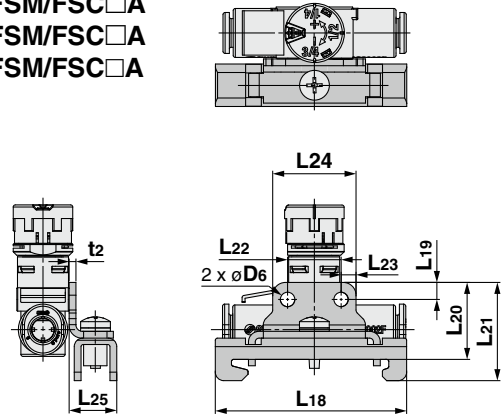

Part no.	Applicable model	D6	L18	L19	L20	L21	L22	L23	L24	L25	t2
AS-10D	AS1002FSM/FSC□A	3.4	45	3.5	18.2	23.2	11	3.5	18	11.3	1.6
AS-20D	AS2002FSM/FSC□A				18.6	23.6	12.6		19.6		
AS-25D	AS2052FSM/FSC□A	4.5	4.4	22	27	17	4.4	25.8			

**Adapter for Manifold Mounting**

Part no.: AS-□□A

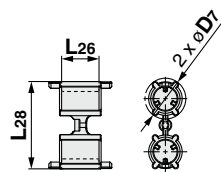

Part no.	Applicable model	D7	L26	L28
AS-10A	AS1002FSM/FSC□A	9.2	4	18.7
AS-20A	AS2002FSM/FSC□A	9.4	8.8	20.4

\* The AS2052FSM/FSC□A can be mounted without the adapter.

**Adapter for Direct Mounting**

Part no.: AS-□□A1

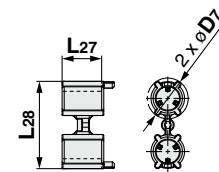

Part no.	Applicable model	D7	L27	L28
AS-10A1	AS1002FSM/FSC□A	9.2	4.5	18.7
AS-20A1	AS2002FSM/FSC□A	9.4	9.3	20.4

\* The AS2052FSM/FSC□A can be mounted without the adapter.

**L-Bracket**

Brackets on both sides

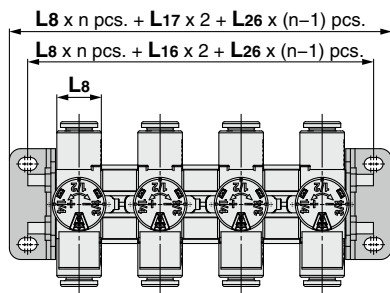

\* Refer to page 15 for L8.  
\* The figure above shows the manifold with speed controllers connected using two L-brackets, adapters and a threaded stud kit for manifold.  
Refer to page 5 for threaded stud kits for manifold.

**DIN Rail Mounting Bracket**

Brackets on both sides

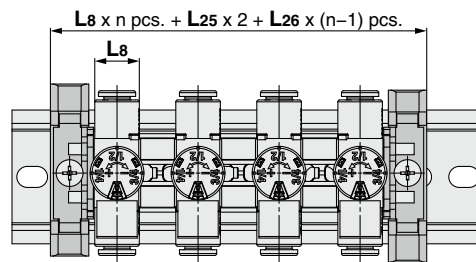

\* Refer to page 15 for L8.  
\* The figure above shows the manifold with speed controllers connected using two DIN rail mounting brackets, adapters and a threaded stud kit for manifold.  
Refer to page 5 for threaded stud kits for manifold.

**Adapter**

Direct mounting

\* For use when the mounting surface interferes with the knob

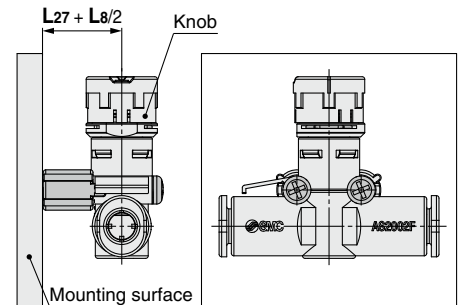

\* Refer to page 15 for L8.

1 to 50 mm/s 50 to 150 mm/s

# AS-FSMA/FSCA Series

## Made to Order

Please contact SMC for detailed dimensions, specifications and lead times.

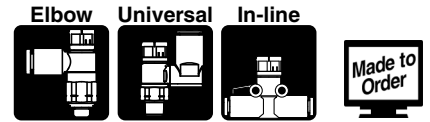

### 1 Lubricant: Vaseline -X12

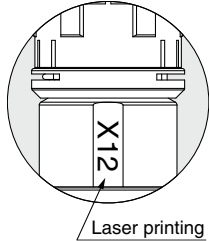

Example) AS2201FSM/FSC-01-04SA-X12

- **Standard model number**  
( Elbow type/Universal type ⇨ page 2 )  
( In-line type ⇨ page 4 )

### 2 Grease-free (Seal: Fluorine-coated) + Restrictor (Without check valve) -X21

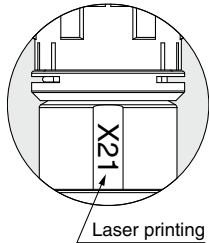

Example) AS2201FSM/FSC-01-04SA-X21

- **Standard model number**  
( Elbow type/Universal type ⇨ page 2 )  
( In-line type ⇨ page 4 )

- \* Not particle-free
- \* Direction is not specified as there is no check valve. Products are available by the product number for meter-out type. Product number for meter-in type is not available. (For the elbow/universal type)
- \* Only the needle and O-ring are fluorine-coated.
- \* The parts in contact with fluid are grease-free.

### 3 Restrictor (Without check valve) -X214

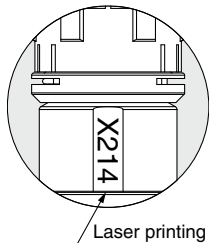

Example) AS2201FSM/FSC-01-04SA-X214

- **Standard model number**  
( Elbow type/Universal type ⇨ page 2 )  
( In-line type ⇨ page 4 )

- \* Direction is not specified as there is no check valve. Products are available by the product number for meter-out type. Product number for meter-in type is not available. (For the elbow/universal type)

### 4 Clean series 10-

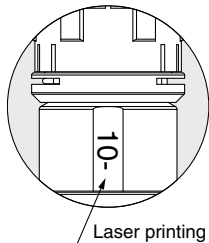

Example) 10-AS2201FSM/FSC-01-04SA

- **Standard model number**  
( Elbow type/Universal type ⇨ page 2 )  
( In-line type ⇨ page 4 )

- \* Fluorine grease is used.
- \* The cleanliness class (ISO class) is 5.



# AS-FSMA/FSCA Series Specific Product Precautions 1

Be sure to read this before handling the products. Refer to the back cover for safety instructions. For flow control equipment precautions, refer to the “Handling Precautions for SMC Products” and the “Operation Manual” on the SMC website.

## Design and Selection

### Warning

#### 1. Check the specifications.

The products in this catalog are designed to be used in compressed air systems (including vacuum) only.

If the products are used in an environment where pressure or temperature is out of the specified range, damage and/or malfunction may result. Do not use under such conditions. (Refer to the specifications.)

Please contact SMC when using a fluid other than compressed air (including vacuum).

We do not guarantee against any damage if the product is used outside of the specification range.

#### 2. The products in this catalog are not designed for the use as stop valve with zero air leakage.

A certain amount of leakage is allowed in the product's specifications.

Tightening the needle to reduce leakage to zero may result in equipment damage.

#### 3. Do not disassemble the product or make any modifications, including additional machining.

It may cause human injury and/or an accident.

#### 4. The flow rate characteristics for each product are representative values.

The flow rate characteristics are characteristics of each individual product. Actual values may differ depending on the piping, circuitry, pressure conditions, etc.

#### 5. Sonic conductance (C) and critical pressure ratio (b) values for products are representative values.

The speed controller's controlled flow values are with the needle fully open and free flow with the needle fully closed.

#### 6. Check if PTFE can be used in the application.

PTFE powder (Polytetrafluoroethylene resin) is included in the seal material of the male thread type piping taper thread. Confirm that the use of it will not cause any adverse effects on the system.

Please contact SMC if the Safety Data Sheet (SDS) is required.

#### 7. Speed controllers are designed to control the speed of the actuator.

When it is used for adjusting the flow rate of the air blow, use a restrictor without a check valve function (X214 or X21).

## Mounting

### Warning

#### 1. Operation Manual

Install the products and operate them only after reading the Operation Manual carefully and understanding its contents. Also, keep the Operation Manual where it can be referred to as necessary.

#### 2. Ensure sufficient space for maintenance activities.

When installing the products, allow access for maintenance.

#### 3. Tighten threads with the proper tightening torque.

When installing the products, follow the listed proper torque.

## Mounting

### Warning

#### 4. After pushing the knob down to lock, confirm that it is locked.

It should not be possible to rotate the knob to the right or to the left. If the knob is pulled with force, it may break. Do not pull the knob with excessive force.



Locked

Unlocked

#### 5. Slowly turn the knob in the opening direction or closing direction.

(Guide for rotation speed: 1 [rev/sec] or below)

Connection thread size	Guide for rotation speed [rev/sec]
M5	1 or less
1/8	1 or less
1/4	0.9 or less

If quick reciprocal operations between two graduations like 0 → 1 → 0, which is not conducted in usual flow rate setting, are conducted, a scale malfunctioning may occur.

#### 6. Do not turn the knob forcibly to prevent the scale from going outside the scale display range.

The scale may indicate a wrong value, possibly leading to a wrong setting.

Wrong use example: While the scale indication range is 0 to 8, forcefully turning the knob in the opening direction from graduation 8 caused the scale to indicate 0.

Connection thread size	Scale indication range
M5	0 to 8 graduations
1/8, 1/4	0 to 10 graduations

The scale indication range is also printed on the product.



#### 7. Do not use tools such as pliers to rotate the knob.

It can cause idle rotation of the knob or damage.

#### 8. Verify the air flow direction.

Mounting backward is dangerous, because the speed adjustment needle will not work and the actuator may lurch suddenly.

#### 9. Adjust the speed by opening the needle slowly from the fully closed state.

Loose needle valves may cause unexpected sudden actuator lurching.

When a needle valve is turned clockwise, it is closed and actuator speed decreases. When a needle valve is turned counter-clockwise, it is open and actuator speed increases.



# AS-FSMA/FSCA Series Specific Product Precautions 2

Be sure to read this before handling the products. Refer to the back cover for safety instructions. For flow control equipment precautions, refer to the “Handling Precautions for SMC Products” and the “Operation Manual” on the SMC website.

## Mounting

### Warning

10. Do not apply excessive force or shock to the body, indicator part, or fittings with an impact tool.

It can cause damage or air leakage.

11. Refer to the Fittings and Tubing Precautions on the SMC website for handling One-touch fittings.

12. Tubing O.D.  $\phi 2$

Tubing other than that from SMC cannot be used because it may result in the inability to connect the tube, air leakage after connecting the tube, or disconnection of the tube.

13. To install/remove the product, use an appropriate wrench to tighten/loosen at the supplied nut on body B.

Do not apply torque at other points, as the product may be damaged. Rotate body A manually for positioning after installation.

14. Do not use body A and/or elbow body for applications involving continuous rotation.

Body A and the fitting section may be damaged.

#### Universal



### Caution

For M5, 10-32UNF

#### Tightening method

First, tighten it by hand, then give it an additional 1/6 turn to 1/4 turn with a wrench. The reference value for the tightening torque is 1 to 1.5 N·m.

\* Excessive tightening may damage the thread portion or deform the gasket and cause air leakage.

If the screw is too shallowly screwed in, it may come loose or air may leak.

#### Chamfered area for female thread

1. In compliance with ISO 16030 Standards (air pressure fluid dynamics – connection – ports and stud ends), the chamfered thread sizes shown below are recommended.

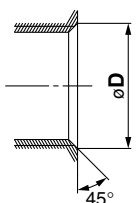

Connection thread size	Chamfer dimension $\phi D$ (Recommended value)
M5	5.1 to 5.4
10-32UNF	5.0 to 5.3

### Caution

For R, NPT Thread (With sealant)

#### Tightening method

1. The proper tightening torques of the fittings are as shown in the table below.

As a guide, tighten it by hand, then turn it two or three turns with a wrench.

Check the dimensions of each product for the hexagon width across flats.

Connection thread size	Proper tightening torque [N·m]
NPT, R1/8	3 to 5
NPT, R1/4	8 to 12

#### Chamfered area for female thread

By chamfering as shown in the following table, machining of threads is easier and effective for burr prevention.

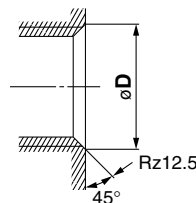

Connection thread size	Chamfer dimension $\phi D$ (Recommended value)	
	Rc	NPT, NPTF
1/8	10.2 to 10.4	10.5 to 10.7
1/4	13.6 to 13.8	14.1 to 14.3

\* For Uni thread, Rz 12.5 is necessary for sealing at the chamfered part.

### For G Thread (Face seal)

#### Tightening method

When using a connection thread, perform tightening to the appropriate tightening torque as shown below.

As a guide, tighten it by hand, then turn it two or three turns with a wrench.

Check the tool by referring to the dimension table of each product.

Connection thread size	Proper tightening torque [N·m]
G1/8	3 to 5
G1/4	8 to 12

#### Chamfered area for female thread (Recommended value)

1. Conforming to ISO 16030-2001, the chamfered dimensions shown in the table below are recommended. By chamfering as shown in the table below, machining of threads is easier and effective for burr prevention.

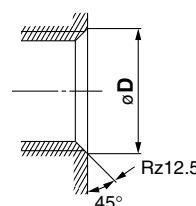

Connection thread size	Chamfer dimension $\phi D$	
	Min.	Max.
1/8	9.8	10.2
1/4	13.3	13.7

2. Use G external threads with G internal threads.



# AS-FSMA/FSCA Series Specific Product Precautions 3

Be sure to read this before handling the products. Refer to the back cover for safety instructions. For flow control equipment precautions, refer to the “Handling Precautions for SMC Products” and the “Operation Manual” on the SMC website.

## Mounting

### ⚠ Caution

- This product has a stopper for fully close in rotating direction. Excess torque may break the stopper. Table below shows the max. allowable torque of the knob.

Connection thread size	Max. allowable torque [N·m]
M5	0.05
1/8	0.07
1/4	0.16

When performing the piping work, turn the tightening tool in the horizontal direction to the hexagon across flats of the body B so that any moment is not applied to the body A. If the tool is in contact with the body A, this may cause the body B to come off.

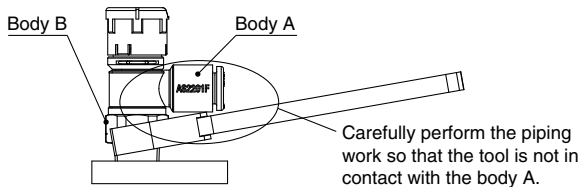

- Actuator speed needs to be checked each time the setting is changed.

Individual product difference due to tolerance of the components, individual actuator difference, operating conditions and temperature, etc. may cause a large variation in the actuator speed, and for this reason, the final actuator speed needs to be checked every time the setting is changed.

- Force for lifting the knob is specified as shown in the table below.

Larger lifting force than specified in the table below will cause removal of the knob, flow rate not according to the flow rate characteristics curve, incorrect flow indication with the indicator or damage to the product.

Connection thread size	Knob lifting force
M5 10/32-UNF	1 to 1.5 N
1/8, 1/4	3.5 to 4 N

- When a torque is applied to the knob or spacer with the knob lock engaged, an erroneous operation or breakage of the scale may occur. Perform mounting by hooking a wrench to the hexagonal part.

## Reference Point

The reference point (scale zero point) of this product differs depending on the product number.

Refer to the following for details.

### Elbow type



### Universal type

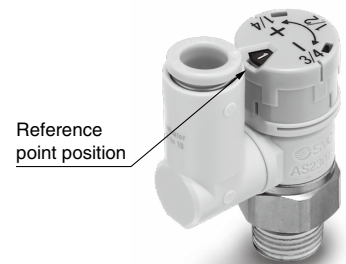

### In-line type (Body size 100)

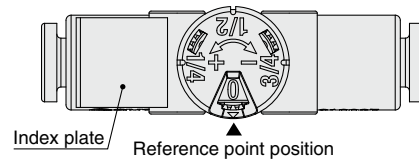

### In-line type (Body size 200, 205)

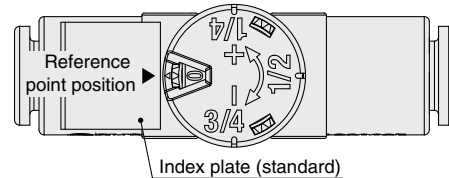

## Piping Threads with Sealant

### ⚠ Caution

- If the fitting is tightened with excessive torque, a large amount of sealant will seep out. Remove the excess sealant.
- Insufficient tightening may loosen the threads or cause air leakage.
- For reuse
  - Normally, fittings with a sealant can be reused up to 2 to 3 times.
  - To prevent air leakage through the sealant, remove any loose sealant stuck to the fitting by blowing air over the threaded portion.
  - If the sealant no longer provides effective sealing, wind sealant tape over the sealant before reusing. Do not use any form other than the tape type of sealant.
- Once the fitting has been tightened, backing it out to its original position often causes the sealant to become defective. Air leakage will occur.
- Use R external threads with Rc internal threads and NPT external threads with NPT internal threads.



# AS-FSMA/FSCA Series

## Specific Product Precautions 4

Be sure to read this before handling the products. Refer to the back cover for safety instructions. For flow control equipment precautions, refer to the “Handling Precautions for SMC Products” and the “Operation Manual” on the SMC website.

### Piping

#### Caution

**1. Refer to the Fittings and Tubing Precautions on the SMC website for handling One-touch fittings.**

**2. Preparation before piping**

Before piping is connected, it should be thoroughly blown out with air (flushing) or washed to remove chips, cutting oil, and other debris from inside the pipe.

**3. Winding of sealant tape**

When screwing piping or fittings into ports, ensure that chips from the pipe threads or sealing material do not enter the piping. Also, if sealant tape is used, leave 1 thread ridge exposed at the end of the threads.

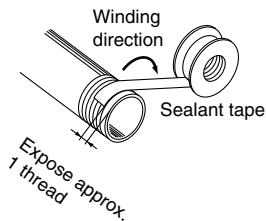

## Safety Instructions

These safety instructions are intended to prevent hazardous situations and/or equipment damage. These instructions indicate the level of potential hazard with the labels of “**Caution**,” “**Warning**” or “**Danger**.” They are all important notes for safety and must be followed in addition to International Standards (ISO/IEC)\*1), and other safety regulations.

 **Caution:** **Caution** indicates a hazard with a low level of risk which, if not avoided, could result in minor or moderate injury.

 **Warning:** **Warning** indicates a hazard with a medium level of risk which, if not avoided, could result in death or serious injury.

 **Danger:** **Danger** indicates a hazard with a high level of risk which, if not avoided, will result in death or serious injury.

\*1) ISO 4414: Pneumatic fluid power – General rules relating to systems.  
ISO 4413: Hydraulic fluid power – General rules relating to systems.  
IEC 60204-1: Safety of machinery – Electrical equipment of machines.  
(Part 1: General requirements)  
ISO 10218-1: Manipulating industrial robots – Safety.  
etc.

### Warning

#### 1. The compatibility of the product is the responsibility of the person who designs the equipment or decides its specifications.

Since the product specified here is used under various operating conditions, its compatibility with specific equipment must be decided by the person who designs the equipment or decides its specifications based on necessary analysis and test results. The expected performance and safety assurance of the equipment will be the responsibility of the person who has determined its compatibility with the product. This person should also continuously review all specifications of the product referring to its latest catalog information, with a view to giving due consideration to any possibility of equipment failure when configuring the equipment.

#### 2. Only personnel with appropriate training should operate machinery and equipment.

The product specified here may become unsafe if handled incorrectly. The assembly, operation and maintenance of machines or equipment including our products must be performed by an operator who is appropriately trained and experienced.

#### 3. Do not service or attempt to remove product and machinery/equipment until safety is confirmed.

1. The inspection and maintenance of machinery/equipment should only be performed after measures to prevent falling or runaway of the driven objects have been confirmed.
2. When the product is to be removed, confirm that the safety measures as mentioned above are implemented and the power from any appropriate source is cut, and read and understand the specific product precautions of all relevant products carefully.
3. Before machinery/equipment is restarted, take measures to prevent unexpected operation and malfunction.

#### 4. Contact SMC beforehand and take special consideration of safety measures if the product is to be used in any of the following conditions.

1. Conditions and environments outside of the given specifications, or use outdoors or in a place exposed to direct sunlight.
2. Installation on equipment in conjunction with atomic energy, railways, air navigation, space, shipping, vehicles, military, medical treatment, combustion and recreation, or equipment in contact with food and beverages, emergency stop circuits, clutch and brake circuits in press applications, safety equipment or other applications unsuitable for the standard specifications described in the product catalog.
3. An application which could have negative effects on people, property, or animals requiring special safety analysis.
4. Use in an interlock circuit, which requires the provision of double interlock for possible failure by using a mechanical protective function, and periodical checks to confirm proper operation.

### Caution

#### 1. The product is provided for use in manufacturing industries.

The product herein described is basically provided for peaceful use in manufacturing industries.  
If considering using the product in other industries, consult SMC beforehand and exchange specifications or a contract if necessary.  
If anything is unclear, contact your nearest sales branch.

### Limited warranty and Disclaimer/ Compliance Requirements

The product used is subject to the following “Limited warranty and Disclaimer” and “Compliance Requirements”.

Read and accept them before using the product.

#### Limited warranty and Disclaimer

1. The warranty period of the product is 1 year in service or 1.5 years after the product is delivered, whichever is first.\*2)  
Also, the product may have specified durability, running distance or replacement parts. Please consult your nearest sales branch.
2. For any failure or damage reported within the warranty period which is clearly our responsibility, a replacement product or necessary parts will be provided.  
This limited warranty applies only to our product independently, and not to any other damage incurred due to the failure of the product.
3. Prior to using SMC products, please read and understand the warranty terms and disclaimers noted in the specified catalog for the particular products.

##### \*2) Vacuum pads are excluded from this 1 year warranty.

A vacuum pad is a consumable part, so it is warranted for a year after it is delivered.  
Also, even within the warranty period, the wear of a product due to the use of the vacuum pad or failure due to the deterioration of rubber material are not covered by the limited warranty.

#### Compliance Requirements

1. The use of SMC products with production equipment for the manufacture of weapons of mass destruction (WMD) or any other weapon is strictly prohibited.
2. The exports of SMC products or technology from one country to another are governed by the relevant security laws and regulations of the countries involved in the transaction. Prior to the shipment of a SMC product to another country, assure that all local rules governing that export are known and followed.

### Caution

#### SMC products are not intended for use as instruments for legal metrology.

Measurement instruments that SMC manufactures or sells have not been qualified by type approval tests relevant to the metrology (measurement) laws of each country. Therefore, SMC products cannot be used for business or certification ordained by the metrology (measurement) laws of each country.

## Safety Instructions

Be sure to read the “Handling Precautions for SMC Products” (M-E03-3) and “Operation Manual” before use.

**SMC Corporation**