

Model with Residual Pressure Release Function

Compact Indicator Type

Speed Controller with Pilot Check Valve

New

RoHS

Model with Residual Pressure Release Function

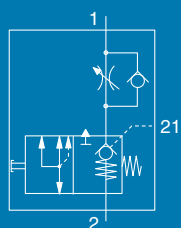

Compact indicator



Residual pressure exhaust button

Model without Residual Pressure Release Function

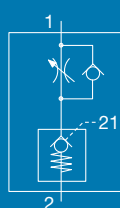

Flow rate control is possible via the compact indicator.

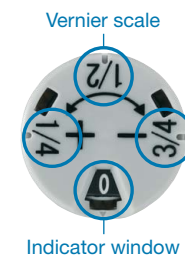

Cylinder pressure can be manually released.

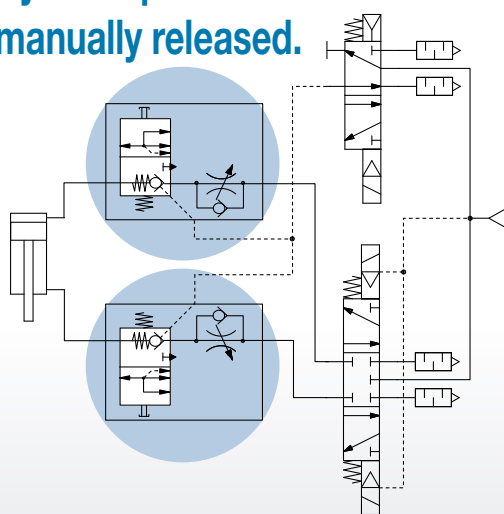

Temporary intermediate stops are possible.*1

*1 Precise intermediate stops are not guaranteed.

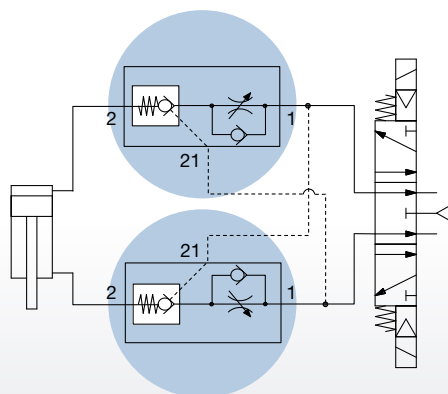

Variations

	Universal	Port size	Pilot port size	Applicable tubing O.D.	Metal material
				Metric size	
Horizontal		M5, 10-32UNF	4, 6, 8, 10, 12	4, 6, 8, 10, 12	Brass
		1/8, 1/4, 3/8, 1/2 (R, NPT, G)			
Vertical		M5, 10-32UNF	4, 6, 8, 10, 12	4, 6, 8, 10, 12	Brass
		1/8, 1/4, 3/8, 1/2 (G)			

ASP-S Series



CAT.ES20-316A

Horizontal and vertical types are available, which can be selected depending on the installation conditions.

Horizontal

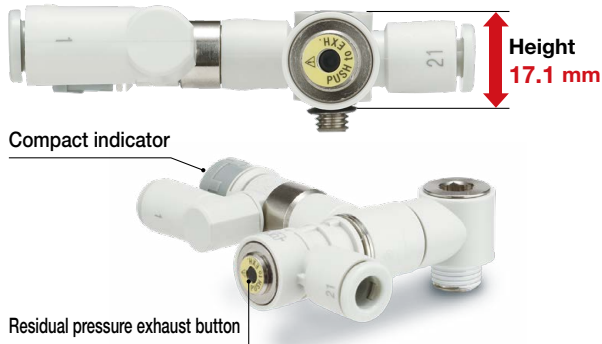

Vertical

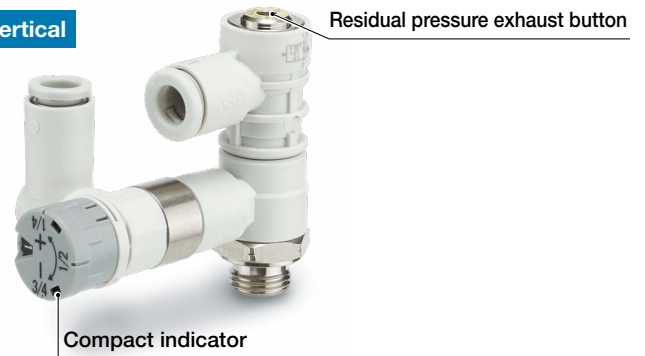



Easily mounted using a hexagon wrench

360° rotatable body
Easy to mount in narrow spaces or with short pitches

Horizontal



Pilot Check Valve Variations by Function

Series	Pilot check valve	Pilot check valve + Residual pressure release valve	Pilot check valve + Speed controller	Pilot check valve + Speed controller + Residual pressure release valve	Compact indicator	Page
Compact Indicator Type ASP-S 	-	-	•	•	•	p. 3
Push-lock Type ASP 	-	-	•	•	-	Web Catalog
Compact Type AKP 	•	•	-	-	-	Web Catalog

Flow rate can be controlled numerically with the indicator window.

Better visibility

Check from 360° directions is possible. Inspection and maintenance works are facilitated.

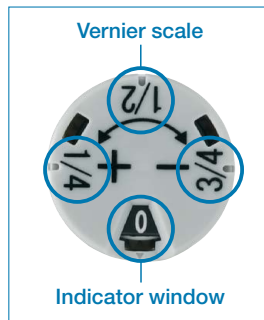

Indicator window	Vernier scale
0	1/4
	1/2
	3/4
⋮	⋮
10 ⁻¹	1/4
	1/2
	3/4

- Due to the vernier indication, it is possible to configure fine settings in 1/4 increments.
- Reduces work-hours and setting mistakes

*1 8 rotations for connection port sizes M5 and 10-32UNF

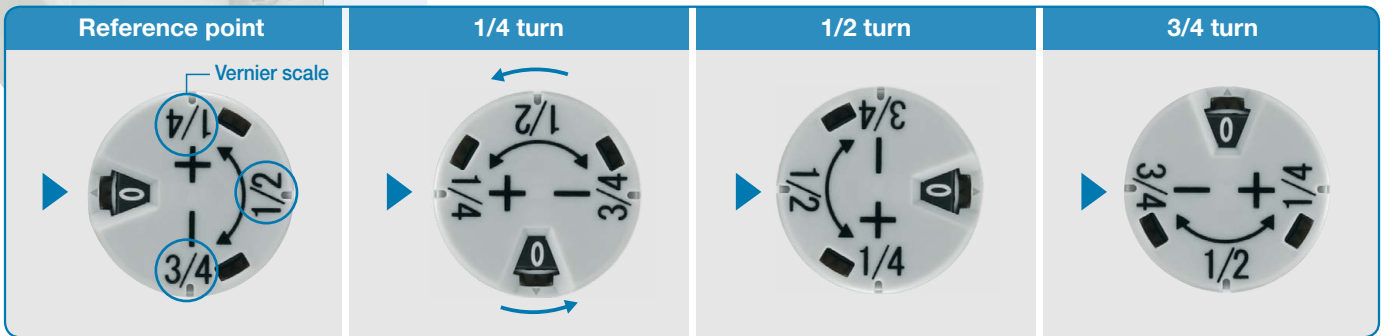

Horizontal



Vertical



CONTENTS

Model.....	p. 3	How to Order	p. 4
Specifications	p. 3	Dimensions	p. 5
Flow Rate and Sonic Conductance	p. 3	Specific Product Precautions	p. 10

Model with Residual Pressure Release Function Compact Indicator Type Speed Controller with Pilot Check Valve **ASP-S Series**

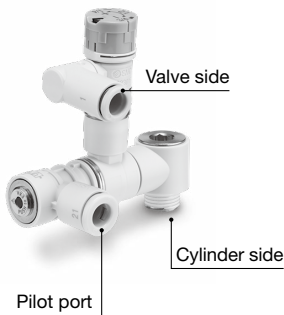
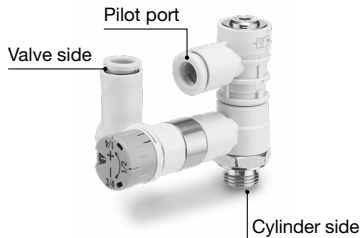

Symbol

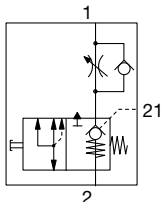

Model with residual pressure release function

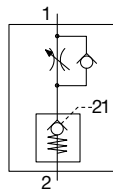

Model without residual pressure release function

Caution

Be sure to read this before handling the products. Refer to the back cover for safety instructions. For flow control equipment precautions, refer to the "Handling Precautions for SMC Products" and the "Operation Manual" on the SMC website.

Model

Vertical type

Port size	Pilot port size	Applicable tubing O.D.				
		Metric size				
		4	6	8	10	12
M5 x 0.8	ø4	●	●	—	—	—
10-32UNF		●	●	—	—	—
G1/8	ø6	—	●	—	—	—
G1/4		—	—	●	—	—
G3/8	ø10	—	—	—	●	—
G1/2		—	—	—	—	●

Horizontal type

Port size	Pilot port size	Applicable tubing O.D.				
		Metric size				
		4	6	8	10	12
M5 x 0.8	ø4	●	●	—	—	—
10-32UNF		●	●	—	—	—
R1/8	ø6	—	●	—	—	—
NPT1/8		—	●	—	—	—
G1/8	ø8	—	●	—	—	—
R1/4		—	—	●	—	—
NPT1/4	ø8	—	—	●	—	—
G1/4		—	—	●	—	—
R3/8	ø10	—	—	—	●	—
NPT3/8		—	—	—	●	—
G3/8	ø10	—	—	—	●	—
R1/2		—	—	—	—	●
NPT1/2	ø12	—	—	—	—	●
G1/2		—	—	—	—	●

Specifications

Fluid	Air
Proof pressure	1.05 MPa
Max. operating pressure	0.7 MPa
Min. operating pressure	0.1 MPa
Pilot check valve operating pressure	50% or more of the cylinder supply pressure {0.1 (0.15*1) MPa or more}
Ambient and fluid temperatures	-5 to 60°C (No freezing)
Applicable tubing material	Nylon, Soft nylon, Polyurethane, FEP, PFA*2

*1 The value in brackets is for the ASP-S□-M5/U10.

*2 Use caution at the max. operating pressure when using soft nylon or polyurethane tubing. (Refer to the Web Catalog for details.)

Flow Rate and Sonic Conductance

Model		ASP-S□-M5/U10	ASP-S□-□01	ASP-S□-□02	ASP-S□-□03	ASP-S□-□04
Tubing O.D.	Metric size	ø4 ø6	ø6	ø8	ø10	ø12
C values: Sonic conductance dm ³ /(s·bar)	Free flow	0.25	0.58	1.06	2.19	3.43
	Controlled flow	0.22	0.46	1.06	1.69	3.09
b values: Critical pressure ratio	Free flow	0.20	0.20	0.15	0.15	0.20
	Controlled flow	0.30	0.20	0.25	0.20	0.30

How to Order



Vertical type ASP-SUA06E-G01

Horizontal type ASP-SUB06E-□01S

Compact indicator

Seal method

Nil	Without sealant
S	With sealant

* Select "Nil: Without sealant" for M5, 10-32UNF, and G thread types.
 Example) ASP-SUB04E-G01

Type

U	Universal
---	-----------

Piping type

A	Vertical
B	Horizontal

Applicable tubing O.D.
 Metric size

04	ø4
06	ø6
08	ø8
10	ø10
12	ø12

* For selecting applicable tubing O.D., refer to the "Model" on page 3.

Port size

M5*1	M5 x 0.8
U10*1	10-32UNF
01	1/8
02	1/4
03	3/8
04	1/2

*1 Use the M5 or U10 port size model in a circuit that uses an exhaust center valve. These sizes cannot be used in a circuit that uses a closed center valve because the responsiveness of the intermediate stop of the actuator may be slow.

Residual pressure release

Nil	Without
E	With

Thread type

Nil	R
N	NPT
G	G

* Select (R: Nil) for connection thread port size M5 or U10.

ASP-S Series

Dimensions

Horizontal Universal type

Seal method: Gasket seal
For M5, 10-32UNF

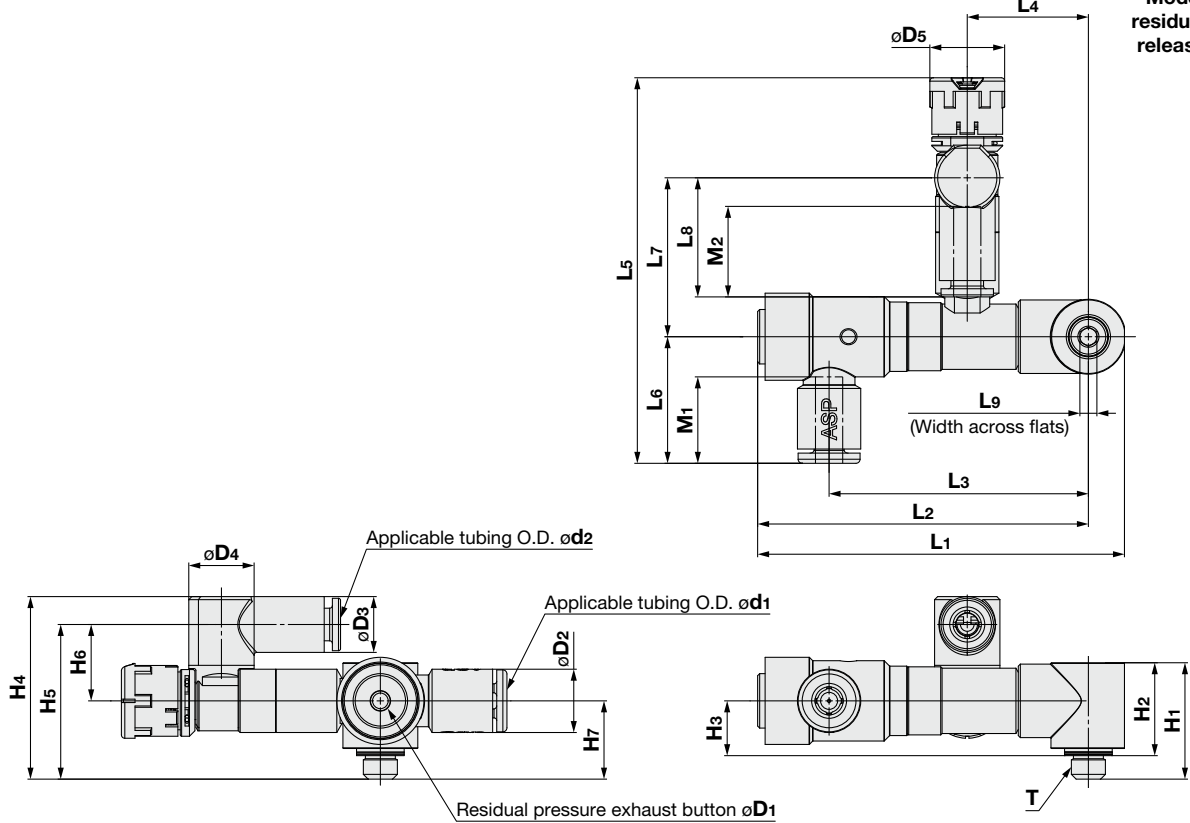
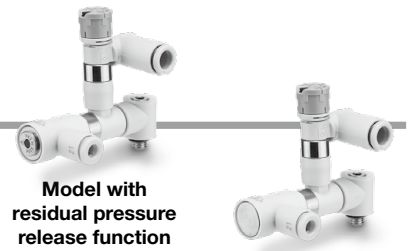

Metric Size

Model	d1	d2	T	D1	D2	D3	D4	D5	L1	L2	L3	L4	L5 [mm]		
													Unlocked	Locked	
ASP-SUB04E-M5	4	4	M5 x 0.8	2.9	9.3	8.2	9.6	11	53.9	48.6	38.1	17.8	58.0	56.9	
ASP-SUB04E-U10			10/32UNF		9.3	8.2	9.6		53.9	48.6	38.1	17.8			
ASP-SUB06E-M5		6	M5 x 0.8	9.3	10.4	9.6	53.9		48.6	38.1	17.8				
ASP-SUB06E-U10			10/32UNF	9.3	10.4	9.6	53.9		48.6	38.1	17.8				
ASP-SUB04-M5		4	M5 x 0.8	-	9.3	8.2	9.6		52.8	47.5	38.1	17.8			
ASP-SUB04-U10			10/32UNF		9.3	8.2	9.6		52.8	47.5	38.1	17.8			
ASP-SUB06-M5			6		M5 x 0.8	9.3	10.4		9.6	52.8	47.5	38.1			17.8
ASP-SUB06-U10					10/32UNF	9.3	10.4		9.6	52.8	47.5	38.1			17.8

Model	L6	L7	L8	L9 (Width across flats)	H1	H2	H3	H4	H5	H6	H7	M1	M2	Weight [g]
ASP-SUB04E-M5	18.6	23.3	17.5	2.5	17.1	13.7	8.1	26.8	22.7	11.2	11.5	12.7	13.3	26
ASP-SUB04E-U10	18.6	23.3	17.5	2.5	17.1	13.7	8.1	26.8	22.7	11.2	11.5	12.7	13.3	25
ASP-SUB06E-M5	18.6	23.3	20.2	2.5	17.1	13.7	8.1	27.9	22.7	11.2	11.5	12.7	13.3	26
ASP-SUB06E-U10	18.6	23.3	20.2	2.5	17.1	13.7	8.1	27.9	22.7	11.2	11.5	12.7	13.3	26
ASP-SUB04-M5	18.6	23.3	17.5	2.5	17.1	13.7	8.1	26.8	22.7	11.2	11.5	12.7	13.3	26
ASP-SUB04-U10	18.6	23.3	17.5	2.5	17.1	13.7	8.1	26.8	22.7	11.2	11.5	12.7	13.3	26
ASP-SUB06-M5	18.6	23.3	20.2	2.5	17.1	13.7	8.1	27.9	22.7	11.2	11.5	12.7	13.3	27
ASP-SUB06-U10	18.6	23.3	20.2	2.5	17.1	13.7	8.1	27.9	22.7	11.2	11.5	12.7	13.3	27

Model with Residual Pressure Release Function Compact Indicator Type
Speed Controller with Pilot Check Valve ASP-S Series

Dimensions

Vertical Universal type

Seal method: Gasket seal
 For M5, 10-32UNF

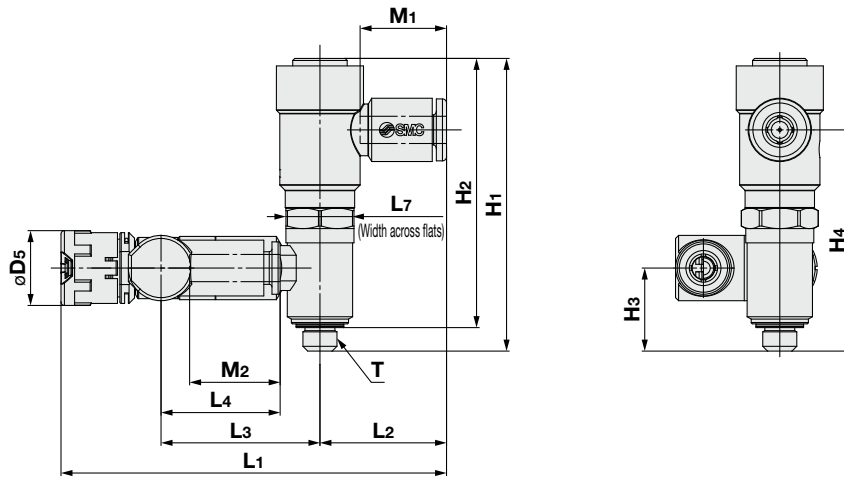
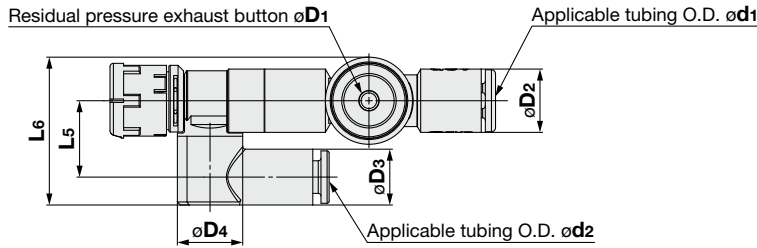
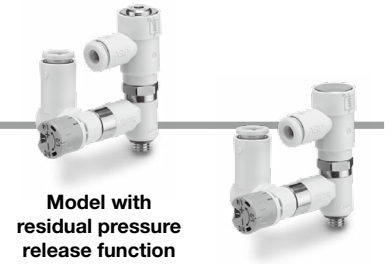

Metric Size

Model	d1	d2	T	D1	D2	D3	D4	D5	L1		L2	L3	
									Unlocked	Locked			
ASP-SUA04E-M5	4	4	M5 x 0.8	2.9	9.3	8.2	9.6	11	58.0	56.9	18.6	23.3	
ASP-SUA04E-U10			10/32UNF		9.3	8.2	9.6				18.6	23.3	
ASP-SUA06E-M5		6	M5 x 0.8	9.3	10.4	9.6	18.6				23.3		
ASP-SUA06E-U10			10/32UNF	9.3	10.4	9.6	18.6				23.4		
ASP-SUA04-M5		4	M5 x 0.8	-	9.3	8.2	9.6				18.6	23.3	
ASP-SUA04-U10			10/32UNF		9.3	8.2	9.6				18.6	23.3	
ASP-SUA06-M5			6		M5 x 0.8	9.3	10.4				9.6	18.6	23.3
ASP-SUA06-U10					10/32UNF	9.3	10.4				9.6	18.6	23.4

Model	L4	L5	L6	L7 (Width across flats)	H1	H2	H3	H4	M1	M2	Weight [g]
ASP-SUA04E-M5	17.5	11.2	21.7	10	43.0	39.6	12.2	32.5	12.7	13.3	22
ASP-SUA04E-U10	17.5	11.2	21.7	10	43.0	39.6	12.2	32.5	12.7	13.3	22
ASP-SUA06E-M5	20.2	11.2	22.8	10	43.0	39.6	12.2	32.5	12.7	13.3	22
ASP-SUA06E-U10	20.4	11.2	22.8	10	43.0	39.6	12.2	32.5	12.7	13.3	22
ASP-SUA04-M5	17.5	11.2	21.7	10	41.9	38.5	12.2	32.5	12.7	13.3	23
ASP-SUA04-U10	17.5	11.2	21.7	10	41.9	38.5	12.2	32.5	12.7	13.3	23
ASP-SUA06-M5	20.2	11.2	22.8	10	41.9	38.5	12.2	32.5	12.7	13.3	23
ASP-SUA06-U10	20.4	11.2	22.8	10	41.9	38.5	12.2	32.5	12.7	13.3	23

ASP-S Series

Dimensions

Horizontal Universal type

Seal method: Sealant
For R, NPT thread

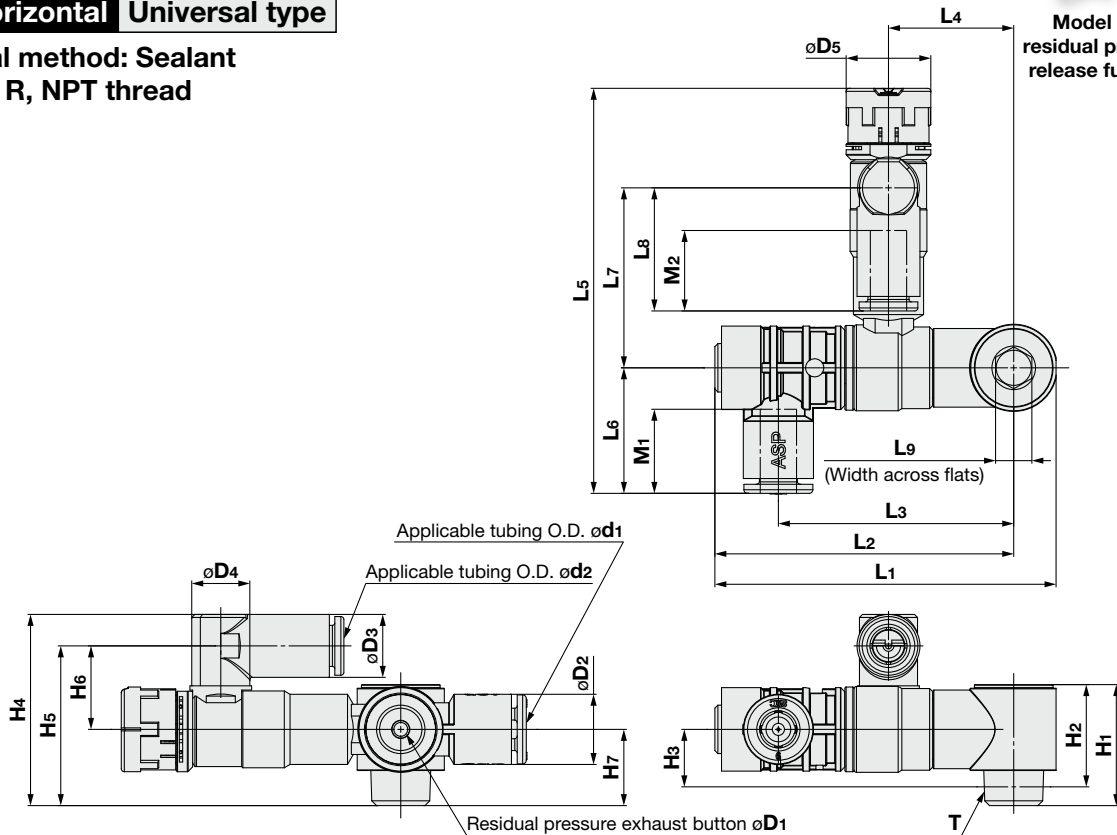
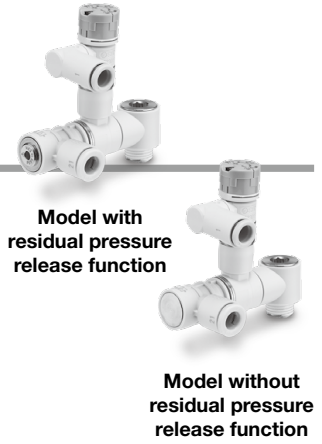

Metric Size

Model	d1	d2	T	D1	D2	D3	D4	D5	L1	L2	L3	L4	L5 [mm]	
													Unlocked	Locked
ASP-SUB06E-01(S)	6	6	R1/8	2.9	11.6	10.4	9.6	14	56.4	49.4	38.9	20.7	68.9	67.5
ASP-SUB08E-02(S)	8	8	R1/4		15.2	13.2	12.9	15	65.5	56.8	46.7	26.8	86.1	84.5
ASP-SUB10E-03(S)	10	10	R3/8		18.5	15.9	17.4	17.7	77.6	67.1	56.5	33.0	98.7	97.1
ASP-SUB12E-04(S)	12	12	R1/2		21.7	18.5	21.0	19.7	93.6	80.8	69.4	38.6	114.3	112.7
ASP-SUB06-01(S)	6	6	R1/8	-	11.6	10.4	9.6	14	55.3	48.3	38.9	20.7	68.9	67.5
ASP-SUB08-02(S)	8	8	R1/4		15.2	13.2	12.9	15	64.6	55.9	46.7	26.8	86.1	84.5
ASP-SUB10-03(S)	10	10	R3/8		18.5	15.9	17.4	17.7	76.6	66.1	56.5	33.0	98.7	97.1
ASP-SUB12-04(S)	12	12	R1/2		21.7	18.5	21.0	19.7	92.6	79.8	69.4	38.6	114.3	112.7
ASP-SUB06E-N01(S)	6	6	NPT1/8	2.9	11.6	10.4	9.6	14	56.4	49.4	38.9	20.7	68.9	67.5
ASP-SUB08E-N02(S)	8	8	NPT1/4		15.2	13.2	12.9	15	65.5	56.8	46.7	26.8	86.1	84.5
ASP-SUB10E-N03(S)	10	10	NPT3/8		18.5	15.9	17.4	17.7	77.6	67.1	56.5	33.0	98.7	97.1
ASP-SUB12E-N04(S)	12	12	NPT1/2		21.7	18.5	21.0	19.7	93.6	80.8	69.4	38.6	114.3	112.7
ASP-SUB06-N01(S)	6	6	NPT1/8	-	11.6	10.4	9.6	14	55.3	48.3	38.9	20.7	68.9	67.5
ASP-SUB08-N02(S)	8	8	NPT1/4		15.2	13.2	12.9	15	64.6	55.9	46.7	26.8	86.1	84.5
ASP-SUB10-N03(S)	10	10	NPT3/8		18.5	15.9	17.4	17.7	76.6	66.1	56.5	33.0	98.7	97.1
ASP-SUB12-N04(S)	12	12	NPT1/2		21.7	18.5	21.0	19.7	92.6	79.8	69.4	38.6	114.3	112.7

Model	L6	L7	L8	L9 (Width across flats)	H1	H2	H3	H4	H5	H6	H7	M1	M2	Weight [g]
ASP-SUB06E-01(S)	20.8	29.8	20.4	6	20.0	16.9	9.5	31.6	26.4	13.8	12.6	13.9	13.3	44
ASP-SUB08E-02(S)	27.2	37.9	23.5	8	30.0	25.3	14.8	45.0	38.4	18.9	19.5	18.7	14.2	95
ASP-SUB10E-03(S)	31.9	45.6	26.1	10	37.7	32.6	18.6	54.6	46.6	22.9	23.7	21.0	15.6	162
ASP-SUB12E-04(S)	35.3	55.3	28.3	10	45.2	38.8	22.8	64.6	55.3	26.1	29.2	22.0	17.0	292
ASP-SUB06-01(S)	20.8	29.8	20.4	6	20.0	16.9	9.5	31.6	26.4	13.8	12.6	13.9	13.3	45
ASP-SUB08-02(S)	27.2	37.9	23.5	8	30.0	25.3	14.8	45.0	38.4	18.9	19.5	18.7	14.2	96
ASP-SUB10-03(S)	31.9	45.6	26.1	10	37.7	32.6	18.6	54.6	46.6	22.9	23.7	21.0	15.6	163
ASP-SUB12-04(S)	35.3	55.3	28.3	10	45.2	38.8	22.8	64.6	55.3	26.1	29.2	22.0	17.0	293
ASP-SUB06E-N01(S)	20.8	29.8	20.4	5.56	20.0	16.8	9.4	31.6	26.4	13.8	12.6	13.9	13.3	45
ASP-SUB08E-N02(S)	27.2	37.9	23.5	7.94	30.3	25.9	16.4	46.3	39.7	18.9	20.8	18.7	14.2	96
ASP-SUB10E-N03(S)	31.9	45.6	26.1	9.53	37.4	32.7	20.2	55.8	47.8	22.9	24.9	21.0	15.6	163
ASP-SUB12E-N04(S)	35.3	55.3	28.3	9.53	44.6	38.2	23.7	65.5	56.2	26.1	30.1	22.0	17.0	291
ASP-SUB06-N01(S)	20.8	29.8	20.4	5.56	20.0	16.8	9.4	31.6	26.4	13.8	12.6	13.9	13.3	45
ASP-SUB08-N02(S)	27.2	37.9	23.5	7.94	30.3	25.9	16.4	46.3	39.7	18.9	20.8	18.7	14.2	97
ASP-SUB10-N03(S)	31.9	45.6	26.1	9.53	37.4	32.7	20.2	55.8	47.8	22.9	24.9	21.0	15.6	163
ASP-SUB12-N04(S)	35.3	55.3	28.3	9.53	44.6	38.2	23.7	65.5	56.2	26.1	30.1	22.0	17.0	292

Model with Residual Pressure Release Function Compact Indicator Type
Speed Controller with Pilot Check Valve ASP-S Series

Dimensions

Vertical Universal type

Seal method: Face seal
 For G

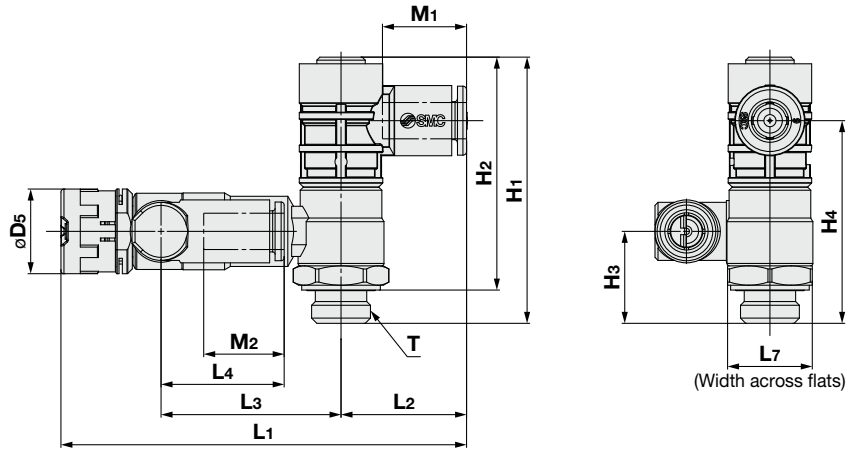
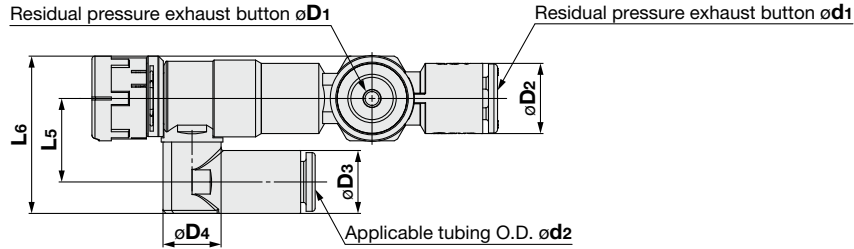
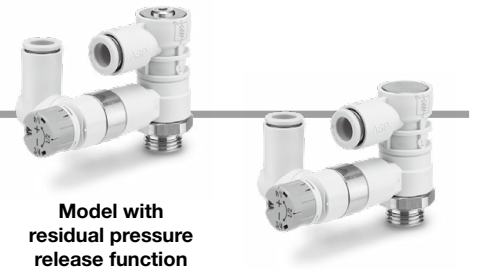

Metric Size

[mm]

Model	d1	d2	T	D1	D2	D3	D4	D5	L1		L2	L3
									Unlocked	Locked		
ASP-SUA06E-G01	6	6	G1/8	2.9	11.6	10.4	9.6	14	68.9	67.5	20.8	29.8
ASP-SUA08E-G02	8	8	G1/4		15.2	13.2	12.9	15	86.1	84.5	27.2	37.9
ASP-SUA10E-G03	10	10	G3/8		18.5	15.9	17.4	17.7	98.7	97.1	31.9	45.6
ASP-SUA12E-G04	12	12	G1/2		21.7	18.5	21	19.7	114.3	112.7	35.3	55.3
ASP-SUA06-G01	6	6	G1/8	-	11.6	10.4	9.6	14	68.9	67.5	20.8	29.8
ASP-SUA08-G02	8	8	G1/4		15.2	13.2	12.9	15	86.1	84.5	27.2	37.9
ASP-SUA10-G03	10	10	G3/8		18.5	15.9	17.4	17.7	98.7	97.1	31.9	45.6
ASP-SUA12-G04	12	12	G1/2		21.7	18.5	21	19.7	114.3	112.7	35.3	55.3

Model	L4	L5	L6	L7 (Width across flats)	H1	H2	H3	H4	M1	M2	Weight [g]
ASP-SUA06E-G01	20.4	13.8	26	14	44.0	38.5	15.2	33.5	13.9	13.3	36
ASP-SUA08E-G02	23.5	18.9	35	19	48.1	41.6	17.1	38	18.7	14.2	74
ASP-SUA10E-G03	26.1	22.9	42.9	24	56.7	49.2	21.8	46.1	21.0	15.6	122
ASP-SUA12E-G04	28.3	26.1	50.4	30	67.8	58.8	25.7	56.4	22.0	17.0	211
ASP-SUA06-G01	20.4	13.8	26	14	42.9	37.4	15.2	33.5	13.9	13.3	37
ASP-SUA08-G02	23.5	18.9	35	19	47.2	40.7	17.1	38	18.7	14.2	74
ASP-SUA10-G03	26.1	22.9	42.9	24	55.7	48.2	21.8	46.1	21.0	15.6	123
ASP-SUA12-G04	28.3	26.1	50.4	30	66.8	57.8	25.7	56.4	22.0	17.0	211

ASP-S Series

Dimensions

Horizontal Universal type

Seal method: Face seal
For G

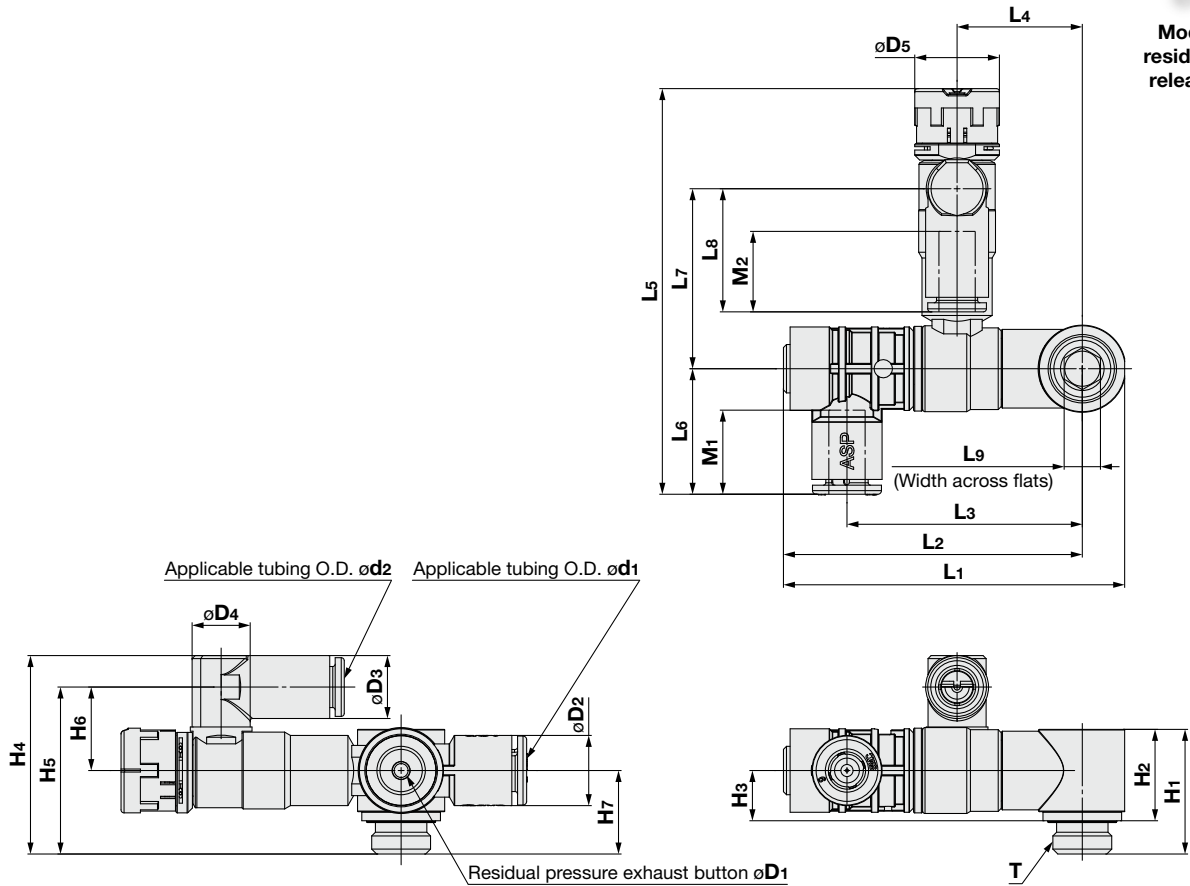
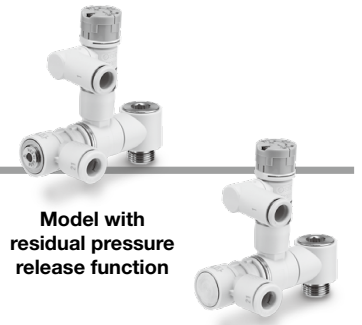

Metric Size

Model	d1	d2	T	D1	D2	D3	D4	D5	L1	L2	L3	L4	L5 [mm]		Weight [g]
													Unlocked	Locked	
ASP-SUB06E-G01	6	6	G1/8	2.9	11.6	10.4	9.6	14	56.4	49.4	38.9	20.7	68.9	67.5	44
ASP-SUB08E-G02	8	8	G1/4		15.2	13.2	12.9	15	65.5	56.8	46.7	26.8	86.1	84.5	
ASP-SUB10E-G03	10	10	G3/8		18.5	15.9	17.4	17.7	77.6	67.1	56.5	33.0	98.7	97.1	
ASP-SUB12E-G04	12	12	G1/2		21.7	18.5	21.0	19.7	93.6	80.8	69.4	38.6	114.3	112.7	
ASP-SUB06-G01	6	6	G1/8	-	11.6	10.4	9.6	14	55.3	48.3	38.9	20.7	68.9	67.5	44
ASP-SUB08-G02	8	8	G1/4		15.2	13.2	12.9	15	64.6	55.9	46.7	26.8	86.1	84.5	
ASP-SUB10-G03	10	10	G3/8		18.5	15.9	17.4	17.7	76.6	66.1	56.5	33.0	98.7	97.1	
ASP-SUB12-G04	12	12	G1/2		21.7	18.5	21.0	19.7	92.6	79.8	69.4	38.6	114.3	112.7	

Model	L6	L7	L8	L9 (Width across flats)	H1	H2	H3	H4	H5	H6	H7	M1	M2	Weight [g]
ASP-SUB06E-G01	20.8	29.8	20.4	6	20.6	15.1	8.3	32.8	27.6	13.8	13.8	13.9	13.3	44
ASP-SUB08E-G02	27.2	37.9	23.5	8	27.8	21.3	11.8	43.8	37.2	18.9	18.3	18.7	14.2	93
ASP-SUB10E-G03	31.9	45.6	26.1	10	34.8	27.3	14.8	53.2	45.2	22.9	22.3	21.0	15.6	157
ASP-SUB12E-G04	35.3	55.3	28.3	10	41.0	32.0	17.5	61.9	52.6	26.1	26.5	22.0	17.0	26
ASP-SUB06-G01	20.8	29.8	20.4	6	20.6	15.1	8.3	32.8	27.6	13.8	13.8	13.9	13.3	45
ASP-SUB08-G02	27.2	37.9	23.5	8	27.8	21.3	11.8	43.8	37.2	18.9	18.3	18.7	14.2	94
ASP-SUB10-G03	31.9	45.6	26.1	10	34.8	27.3	14.8	53.2	45.2	22.9	22.3	21.0	15.6	158
ASP-SUB12-G04	35.3	55.3	28.3	10	41.0	32.0	17.5	61.9	52.6	26.1	26.5	22.0	17.0	283



ASP-S Series Specific Product Precautions 1

Be sure to read this before handling the products. Refer to the back cover for safety instructions. For flow control equipment precautions, refer to the “Handling Precautions for SMC Products” and the “Operation Manual” on the SMC website.

Design

Warning

1. Confirm the specifications.

The products in this catalog are designed to be used in compressed air systems (including vacuum) only.

Do not operate at pressures, temperatures, etc., beyond the range of specifications, as this can cause damage or malfunction. (Refer to the specifications.)

We do not guarantee against any damage if the product is used outside of the specification range.

2. Do not disassemble the product or make any modifications, including additional machining.

Doing so may cause human injury and/or an accident.

3. Sonic conductance (C) and critical pressure ratio (b) values for products are representative values.

4. Check if PTFE can be used in the application.

PTFE powder (Polytetrafluoroethylene resin) is included in the seal material of the male thread type piping taper thread.

Confirm that the use of it will not cause any adverse effects on the system.

Please contact SMC if the Safety Data Sheet (SDS) is required.

5. The pilot check valve is a product aimed at the control of the actuator via a temporary intermediate stop.

The pilot check valve is used for temporarily stopping the actuator. Until a pilot signal is input, the valve shuts off the flow path from 2 to 1 and the actuator stops. When a pilot signal is input, the flow path from 2 to 1 is opened. When the residual pressure exhaust button is operated, all flow paths (2 to 1, 21, and exhaust port) are opened.

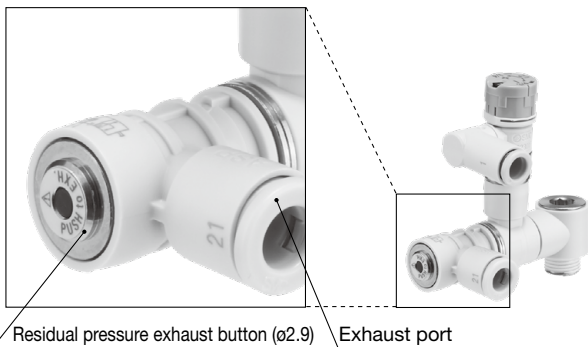
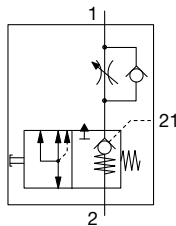

6. This product cannot be used for accurate and precise intermediate stops of the actuator.

Due to the compressibility of air as a fluid, the actuator will continue to move until it reaches a position of pressure balance, even though the pilot check valve closes with an intermediate stop signal.

7. This product cannot be used to hold a stop position for an extended period of time.

Pilot check valves and actuators are not guaranteed for zero air leakage. Therefore, it is sometimes not possible to hold a stop position for an extended period of time. In the event that holding for an extended time is necessary, a mechanical means for holding should be devised.

8. Pay attention to the residual pressure within the actuator at the time of intermediate stop.

When the actuator is stopped at the intermediate position by this product, there may be pressure contained inside the actuator, therefore the actuator may suddenly move when the residual pressure is released. Before operating the residual pressure exhaust button, confirm that the surrounding area is secure from any potential hazards or accidents occurring.

9. Use this product after checking the surrounding areas in advance before the release of residual pressure.

The actuator may move at a speed quicker than the intended speed from the original circuit set up when exhausting from the residual pressure release. Confirm this speed will not create additional hazards and pay attention to the air discharged from the exhaust port.

10. Pay attention to the motion of the actuator at the time of release of the residual pressure.

When operating the residual pressure exhaust button or conducting maintenance or inspection, the actuator may start moving due to the residual pressure. Take appropriate measures in advance to prevent an actuator movement from posing a hazard.

Also pay attention to the operation speed and the movement of the cylinder during exhaust.

When an exhaust center valve is used on the actuator supply side (Figure A below), the residual pressure is released from port 1, 21, and the exhaust port. However, when using a closed center valve like the example shown in Figure B below, air is discharged only from port 21 and the exhaust port.

For the moving direction of the actuator against the corresponding exhaust side, refer to the figure below.

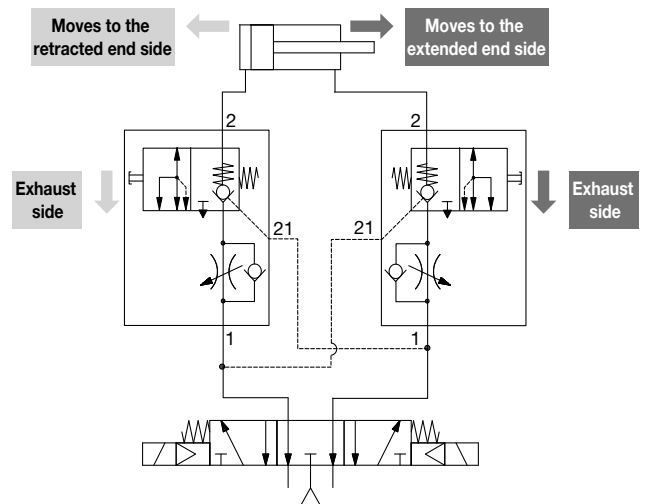

Figure A: Example of piping using exhaust center valve

* Use the model “ASP-S□-M5” or “ASP-S□-U10” in a circuit that uses an exhaust center valve.



ASP-S Series Specific Product Precautions 2

Be sure to read this before handling the products. Refer to the back cover for safety instructions. For flow control equipment precautions, refer to the “Handling Precautions for SMC Products” and the “Operation Manual” on the SMC website.

Design

Warning

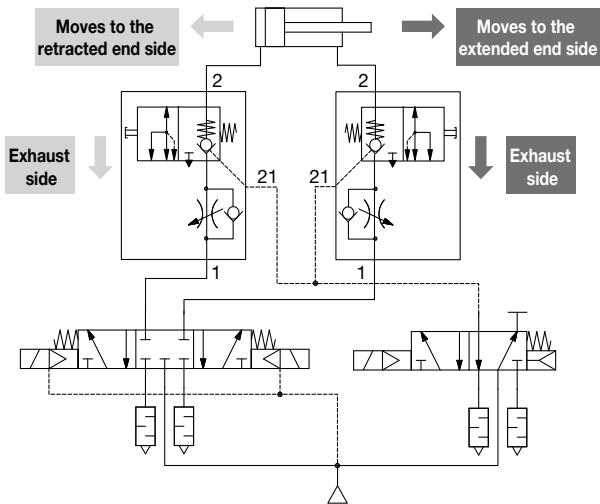

Figure B: Example of piping using closed center valve (Recommended example)

* The model “ASP-S□-M5” or “ASP-S□-U10” cannot be used in a circuit that uses a closed center valve.

11. Push the residual pressure exhaust button all the way to the end position by using a tool.

Push the residual pressure exhaust button all the way to the end position by using a tool having a tip diameter of $\phi 2.8$ or below. Refer to the table below for operating force and depth. Note that the higher the residual pressure, the greater the force required to operate the residual pressure exhaust button.

Model	Operating force [N] (Reference value)	Operating depth [mm]
ASP-S□-M5/U10	5.3 to 8.2	3.5
ASP-S□-□01	5.1 to 11.9	3.9
ASP-S□-□02	6.7 to 19.5	3.8
ASP-S□-□03	10.6 to 34.4	4.7
ASP-S□-□04	17.1 to 54.4	5.8

12. After operating the residual pressure exhaust button, confirm that the button has returned to the normal position.

Make sure that the residual pressure exhaust button has returned to the end face of the product before operating again. If the button cannot return to the normal position, the intermediate stop function of the actuator will not work. Therefore, replace the product with a new one.

13. Pay attention to the motion of the actuator at the time of restart after the release of residual pressure.

When restarting the product after releasing the residual pressure, check the initial driving direction, confirm that the work area is secured, and then restart the product. Failure to follow this instruction may cause the actuator to suddenly move.

14. When the product is used in a balance control circuit, the check valve may not be released even when the pilot pressure is 50% of the operating pressure. In this case, obtain the pilot pressure from a position so that the pilot pressure is equivalent to the operating pressure.

When using the product at the minimum operating pressure, set the pilot pressure to 0.1 MPa or higher. However, for “ASP-S□-M5” or “ASP-S□-U10,” set the pilot pressure to 0.15 MPa or higher.

15. As a reference, we have confirmed through our durability tests that the check valve has a durability against 10 million cycles of ON and OFF operations and the residual pressure exhaust button has a durability against 10,000 cycles of operation at the maximum operating pressure.

However, note that the tests were conducted under limited conditions.

16. In the following cases, malfunctioning or noise due to oscillation may occur.

- When the differential pressure between the port 1 side and port 2 side is smaller than the min. operating pressure
- When the IN side piping of the product or the effective area of the directional control valve is smaller than that of the product
- When the pressure drop on the port 1 side is slower than that of the port 2 side during operation of the product
- When the supply pressure at the port 21 is reduced (Refer to the piping diagram below.)
- When the port 1 side piping (tube) is bent or crushed

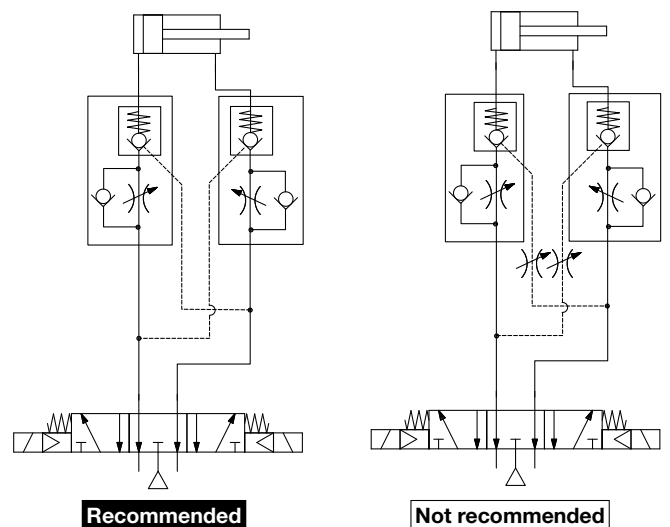

Safety Instructions

These safety instructions are intended to prevent hazardous situations and/or equipment damage. These instructions indicate the level of potential hazard with the labels of “**Caution**,” “**Warning**” or “**Danger**.” They are all important notes for safety and must be followed in addition to International Standards (ISO/IEC)*1), and other safety regulations.

 **Danger :** **Danger** indicates a hazard with a high level of risk which, if not avoided, will result in death or serious injury.

 **Warning:** **Warning** indicates a hazard with a medium level of risk which, if not avoided, could result in death or serious injury.

 **Caution:** **Caution** indicates a hazard with a low level of risk which, if not avoided, could result in minor or moderate injury.

*1) ISO 4414: Pneumatic fluid power - General rules and safety requirements for systems and their components
ISO 4413: Hydraulic fluid power - General rules and safety requirements for systems and their components
IEC 60204-1: Safety of machinery - Electrical equipment of machines - Part 1: General requirements
ISO 10218-1: Robots and robotic devices - Safety requirements for industrial robots - Part 1: Robots etc.

Warning

1. The compatibility of the product is the responsibility of the person who designs the equipment or decides its specifications.

Since the product specified here is used under various operating conditions, its compatibility with specific equipment must be decided by the person who designs the equipment or decides its specifications based on necessary analysis and test results. The expected performance and safety assurance of the equipment will be the responsibility of the person who has determined its compatibility with the product. This person should also continuously review all specifications of the product referring to its latest catalog information, with a view to giving due consideration to any possibility of equipment failure when configuring the equipment.

2. Only personnel with appropriate training should operate machinery and equipment.

The product specified here may become unsafe if handled incorrectly. The assembly, operation and maintenance of machines or equipment including our products must be performed by an operator who is appropriately trained and experienced.

3. Do not service or attempt to remove product and machinery/equipment until safety is confirmed.

1. The inspection and maintenance of machinery/equipment should only be performed after measures to prevent falling or runaway of the driven objects have been confirmed.
2. When the product is to be removed, confirm that the safety measures as mentioned above are implemented and the power from any appropriate source is cut, and read and understand the specific product precautions of all relevant products carefully.
3. Before machinery/equipment is restarted, take measures to prevent unexpected operation and malfunction.

4. SMC products cannot be used beyond their specifications. They are not developed, designed, and manufactured to be used under the following conditions or environments. Use under such conditions or environments is not allowed.

1. Conditions and environments outside of the given specifications, or use outdoors or in a place exposed to direct sunlight.
2. Use for nuclear power, railways, aviation, space equipment, ships, vehicles, military application, equipment affecting human life, body, and property, combustion equipment, entertainment equipment, emergency shut-off circuits, press clutches, brake circuits, safety equipment, etc., and use for applications that do not conform to standard specifications such as catalogs and operation manuals.
3. Use for interlock circuits, except for use with double interlock such as installing a mechanical protection function in case of failure. Please periodically inspect the product to confirm that the product is operating properly.

Caution

SMC develops, designs, and manufactures products to be used for automatic control equipment, and provides them for peaceful use in manufacturing industries.

Use in non-manufacturing industries is not allowed.

Products SMC manufactures and sells cannot be used for the purpose of transactions or certification specified in the Measurement Act of each country. The new Measurement Act prohibits use of any unit other than SI units in Japan.

Limited warranty and Disclaimer/ Compliance Requirements

The product used is subject to the following “Limited warranty and Disclaimer” and “Compliance Requirements”.

Read and accept them before using the product.

Limited warranty and Disclaimer

1. The warranty period of the product is 1 year in service or 1.5 years after the product is delivered, whichever is first.*2)
Also, the product may have specified durability, running distance or replacement parts. Please consult your nearest sales branch.
2. For any failure or damage reported within the warranty period which is clearly our responsibility, a replacement product or necessary parts will be provided.
This limited warranty applies only to our product independently, and not to any other damage incurred due to the failure of the product.
3. Prior to using SMC products, please read and understand the warranty terms and disclaimers noted in the specified catalog for the particular products.

*2) **Vacuum pads are excluded from this 1 year warranty.**

A vacuum pad is a consumable part, so it is warranted for a year after it is delivered.

Also, even within the warranty period, the wear of a product due to the use of the vacuum pad or failure due to the deterioration of rubber material are not allowed by the limited warranty.

Compliance Requirements

1. The use of SMC products with production equipment for the manufacture of weapons of mass destruction (WMD) or any other weapon is strictly prohibited.
2. The exports of SMC products or technology from one country to another are governed by the relevant security laws and regulations of the countries involved in the transaction. Prior to the shipment of a SMC product to another country, assure that all local rules governing that export are known and followed.

Safety Instructions

Be sure to read the “Handling Precautions for SMC Products” (M-E03-3) and “Operation Manual” before use.

SMC Corporation