

Electric Actuator

High Performance

High Rigidity and High Precision Slider Type

Battery-less Absolute (Step Motor 24 VDC)

Reduces cycle time

New

 * For details, refer to page 45.

RoHS

Cycle time

Reduced by **39%** (0.57 s \triangleleft 0.93 s)
 compared with the existing model*¹

*¹ When LESYH25DGA-150 is operated from 0 to 150 mm

Acceleration/ Deceleration

10000 mm/s²
 (334% increase compared with the existing model)

Max. speed

1500 mm/s
 (Improved by 25% compared with the existing model)

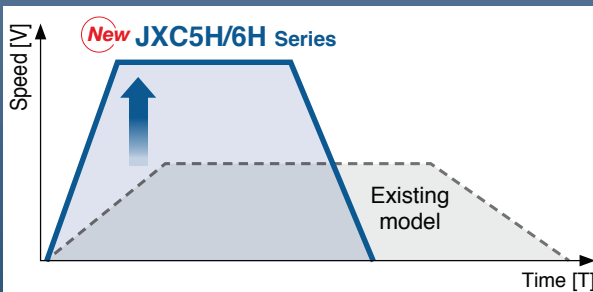

Easy operation restart after recovery of the power supply

The position information is held by the encoder even when the power supply is turned off. A return to origin operation is not necessary when the power supply is recovered.

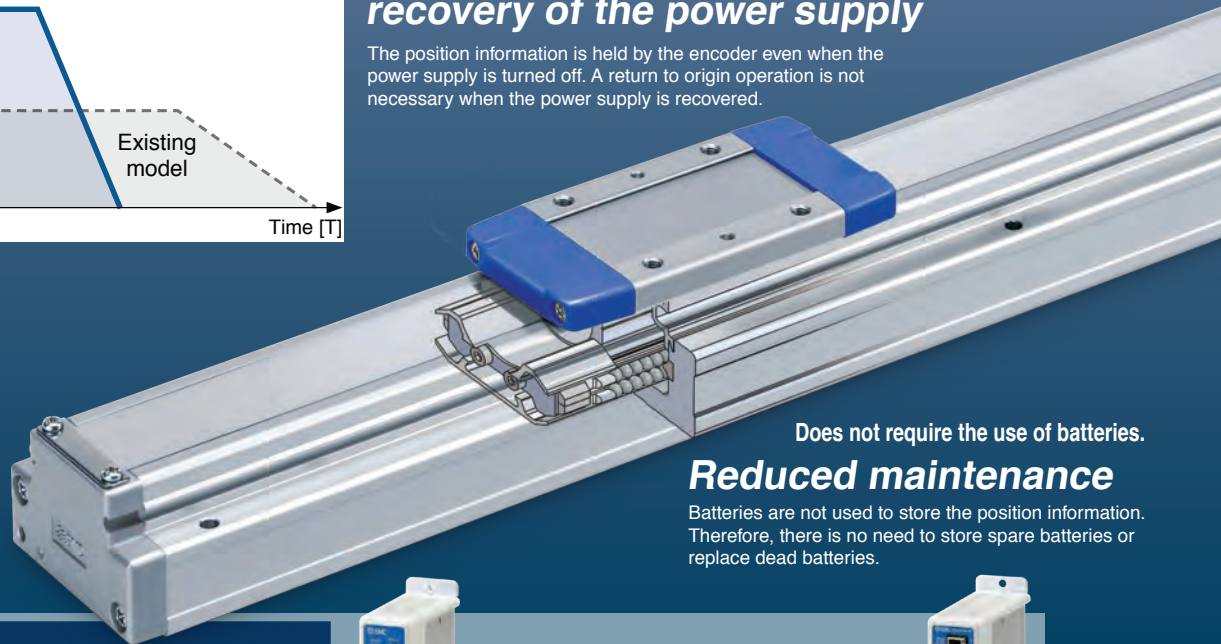

Does not require the use of batteries.

Reduced maintenance

Batteries are not used to store the position information. Therefore, there is no need to store spare batteries or replace dead batteries.

High Performance Step Motor Controller

Higher acceleration and maximum speed can be set with the special controller (for LEKFS□G Series).

Parallel I/O
JXC5H/6H Series p. 31



EtherCAT/EtherNet/IP™/
 PROFINET

JXCEH/9H/PH Series p. 38



With a 4-row circular arc on each side for high rigidity and high precision (zero clearance)

Improved moment resistance

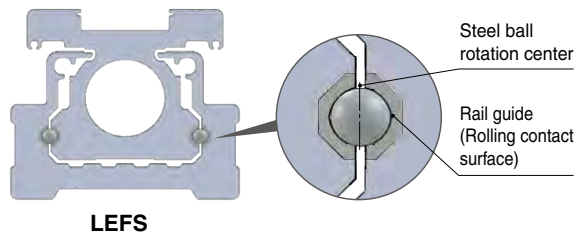
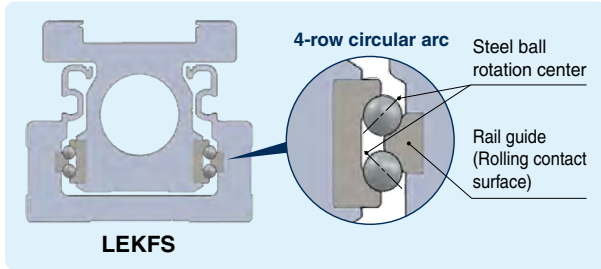

Improved Dynamic Allowable Moment

Size	Moment direction	Work load [kg] (Overhang: 300 mm)	
		High rigidity guide LEKFS	LEFS
25	Pitching (Mep)	7.5 (10% increase)	6.8
32		18 (35% increase)	13.3
40		37 (61% increase)	23

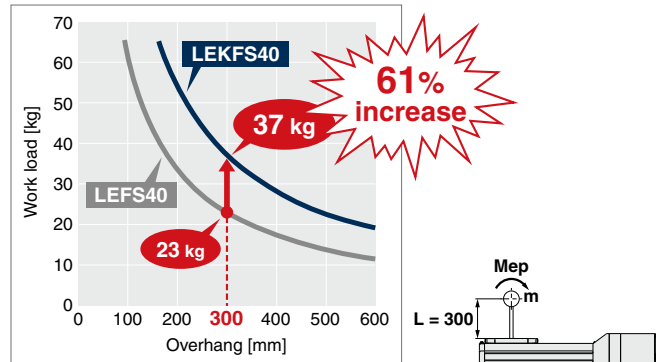

Table displacement amount reduced to 1/2

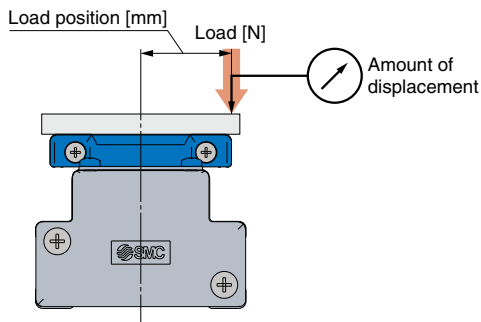

Table Displacement

Size	Table displacement [mm]		Load position [mm]	Load [N]
	High rigidity guide LEKFS	LEFS		
25	0.022 (50% reduction)	0.044	25	200
32	0.036 (50% reduction)	0.072	30	450
40	0.027 (50% reduction)	0.053	37	500

Zero table clearance

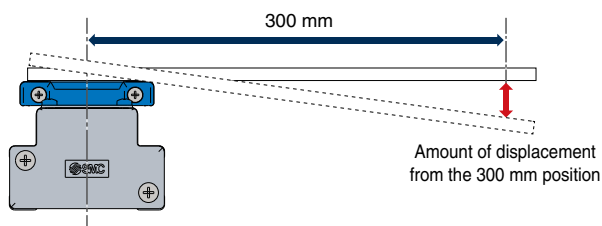

Table Clearance

Size	Displacement due to table clearance [mm]	
	High rigidity guide LEKFS	LEFS
25	0	0.079
32	0	0.068
40	0	0.052

* The image shows the displacement amount with zero load.

Auto switches are mountable.

Allows for position detection of the table throughout the stroke

LEKFS32/40

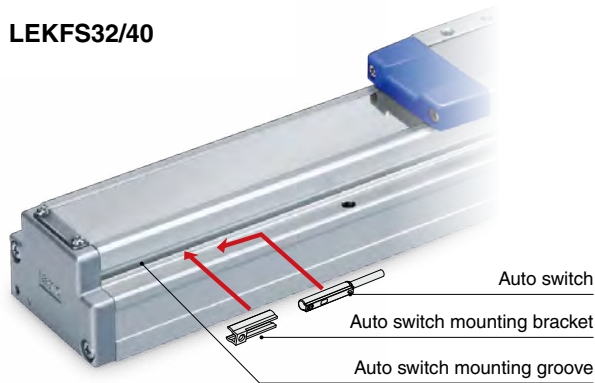

LEKFS25



Same dimensions as the LEF/Complete mounting compatibility is ensured.

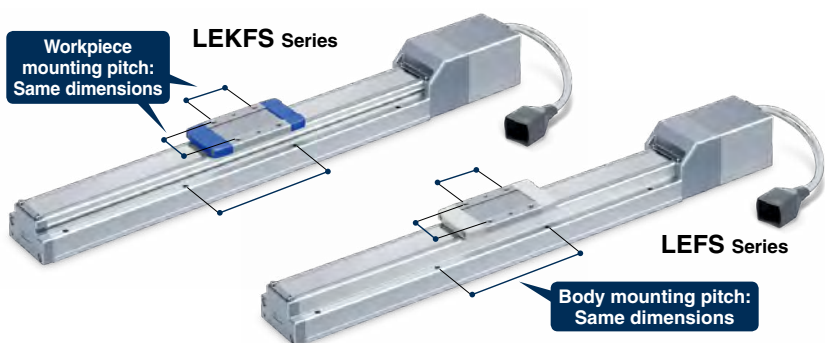
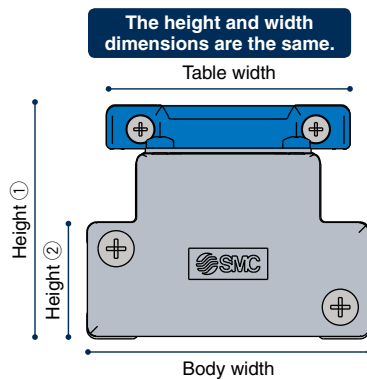

The body bottom positioning pin holes have been standardized.

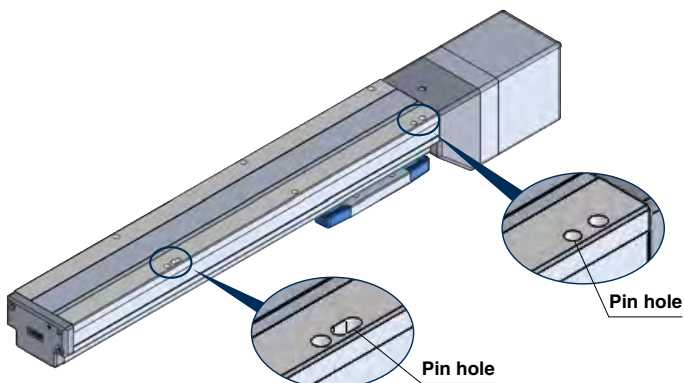

Magnet for adhesion of the dust seal band

Improved adhesion enhances the dustproof performance and reduces dust seal band blistering.

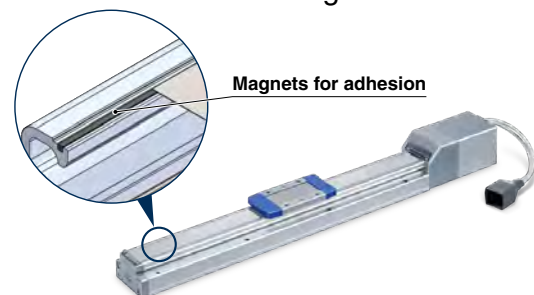

Step Data Input Type JXC5H/6H Series p. 31



ACT 2 Controller Setting Software ACT Controller 2

Easy-to-use setting software ACT Controller 2 (For PC)

Various functions available in normal mode (Compared with the existing ACT Controller)

● **Parameter and step data setting**

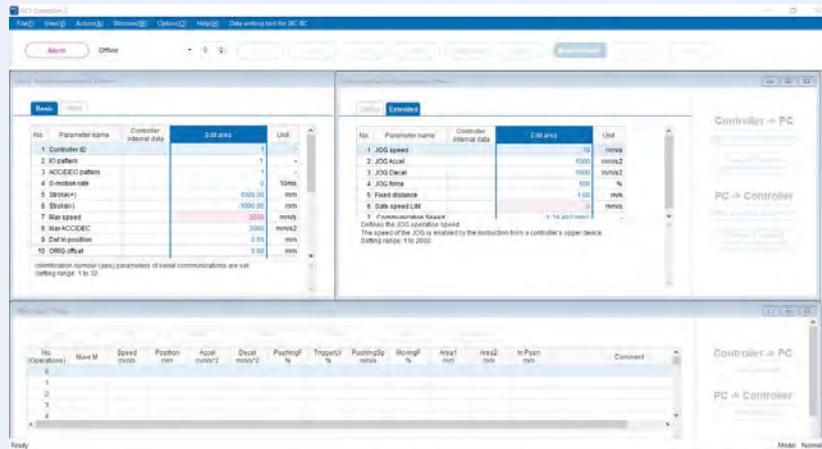

* Customers operating computers with specifications other than Windows 10/64 bit should use the existing ACT Controller.

● **Alarm confirmation**

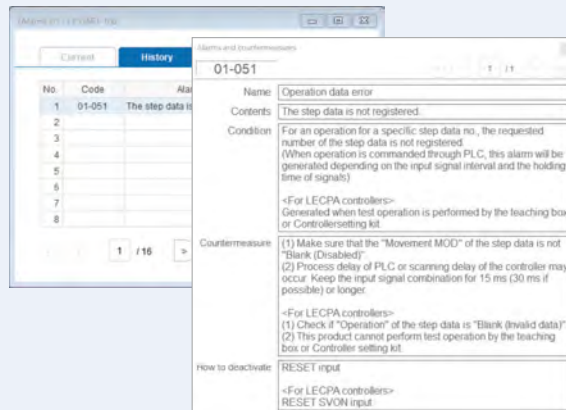

When an alarm is generated, the alarm details and countermeasures can be confirmed.

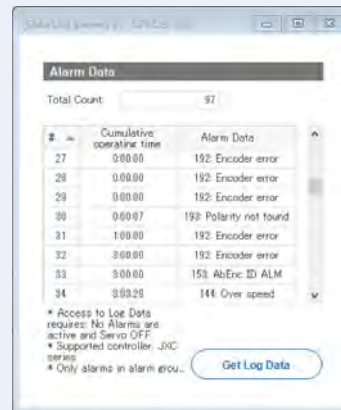

When an alarm is generated, the cumulative startup time of the controller can be confirmed.

● **Waveform monitoring**

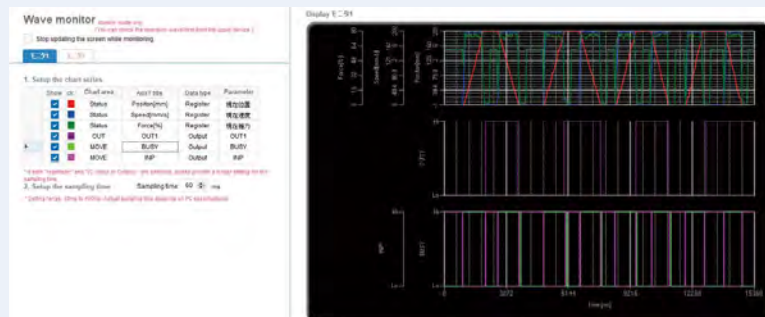

The position, speed, force, and input/output signals' waveform data during operation can be measured.

* When using the ACT Controller 2 test operation function, waveform monitoring is not available.

Step Data Input Type JXC5H/6H Series p. 31



ACT 2 Controller Setting Software ACT Controller 2

• The JXC-BC writing tool

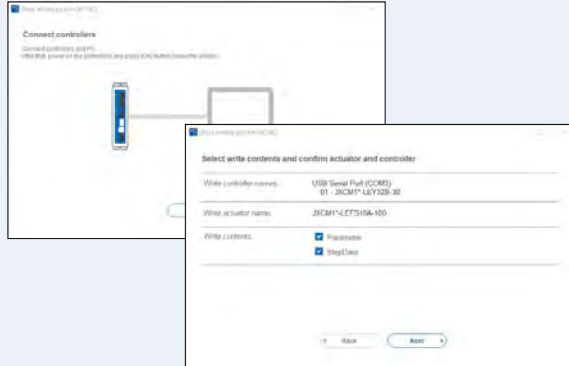

The writing tool can be used to write the connected actuator's parameters and step data to a JXC series blank controller.

• Customizable plug-in functions

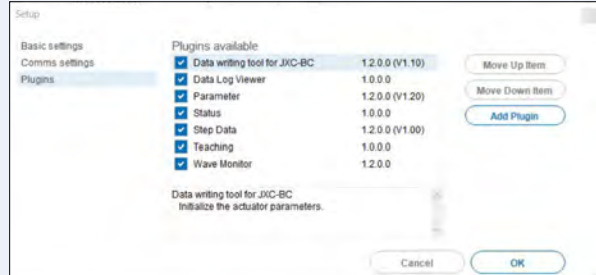

Which plug-in functions are displayed as well as the display order are customizable. Customers can add the functions they require.

In normal mode, various other test operation methods (program operation, jogging, moving of the constant rate, etc.), signal status monitoring, one-touch switching between Japanese and English, and other functions are available.

For immediate use, operate in easy mode.

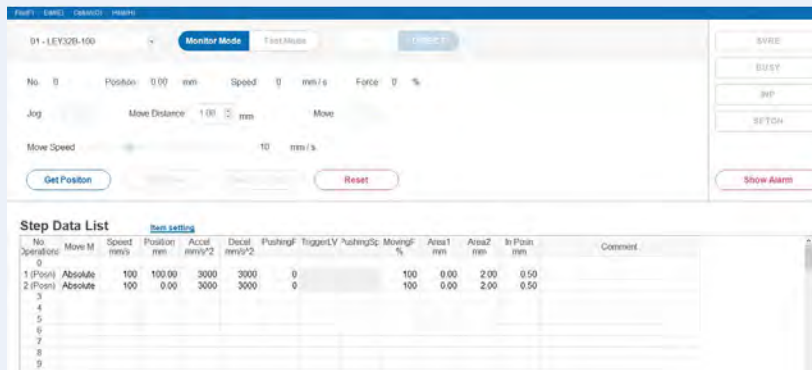

Step data setting, various test operations, and status confirmation can be done on a single screen.

How to download the setting software

Click here for details.

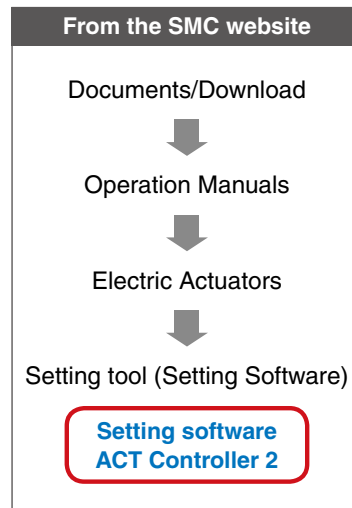
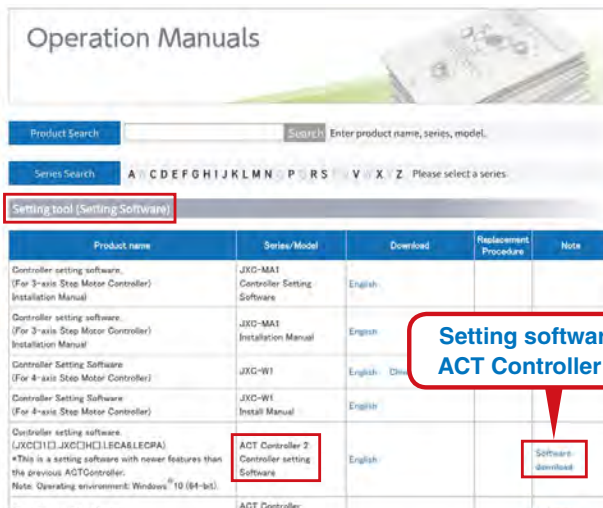

Step Data Input Type JXC5H/6H Series p. 31



Teaching Box

◎ **Normal Mode**

- Multiple step data can be stored in the teaching box and transferred to the controller.
- Continuous test drive by up to 5 step data

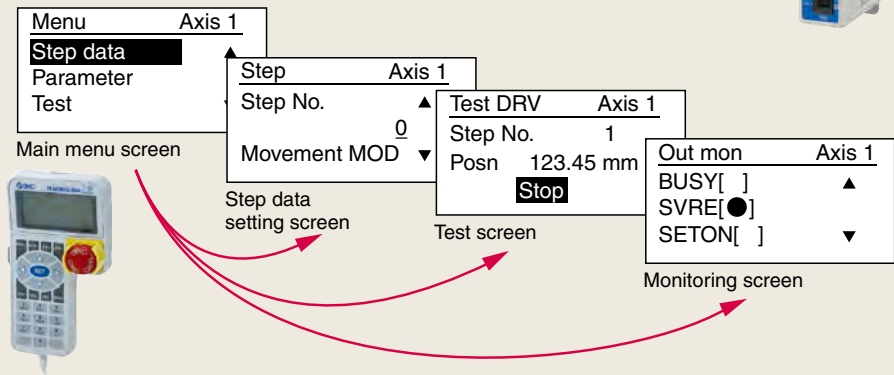

Teaching box screen

- Each function (step data setting, test drive, monitoring, etc.) can be selected from the main menu.

◎ **Easy Mode**

- The simple screen without scrolling promotes ease of setting and operation.
- Choose an icon from the first screen to select a function.
- Set the step data and check the monitor on the second screen.



Example of setting the step data

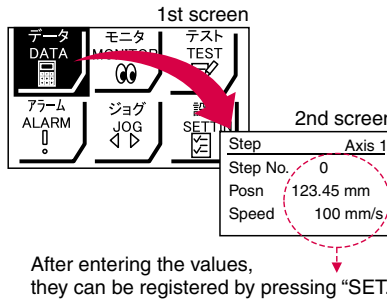

Example of checking the operation status

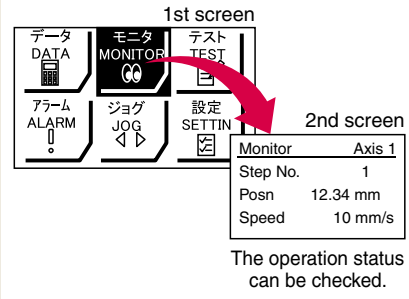

Teaching box screen

- Data can be set by inputting only the position and speed. (Other conditions are preset.)

Step	Axis 1
Step No.	0
Posn	50.00 mm
Speed	200 mm/s



Step	Axis 1
Step No.	1
Posn	80.00 mm
Speed	100 mm/s

The actuator and controller are provided as a set. (They can be ordered separately as well.)

Confirm that the combination of the controller and actuator is correct.

<Check the following before use.>

- ① Check the actuator label for the model number. This number should match that of the controller.
- ② Check that the Parallel I/O configuration matches (NPN or PNP).

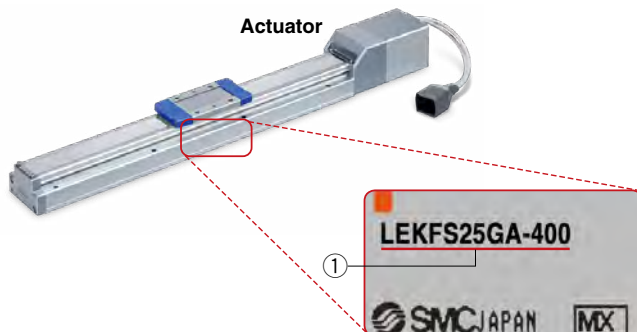

Controller

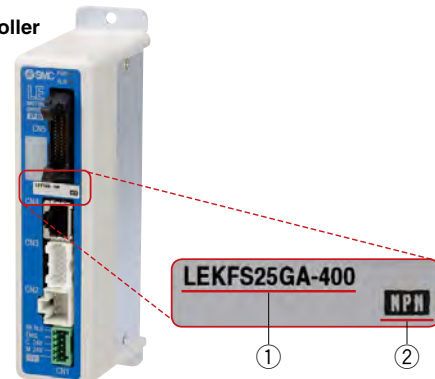

Function

Item	Step data input type JXC5H/6H
Step data and parameter setting	<ul style="list-style-type: none"> Input from controller setting software (PC) Input from teaching box
Step data "position" setting	<ul style="list-style-type: none"> Numerical value input from controller setting software (PC) or teaching box Input numerical value Direct teaching JOG teaching
Number of step data	64 points
Operation command (I/O signal)	Step No. [IN ⁺] input ⇒ [DRIVE] input
Completion signal	[INP] output

Setting Items

TB: Teaching box PC: Controller setting software

Item	Contents	Easy Mode		Normal Mode	Step data input type JXC5H/6H	
		TB	PC	TB/PC		
Step data setting (Excerpt)	Movement MOD	Selection of "absolute position" and "relative position"	△	●	●	Set at ABS/INC
	Speed	Transfer speed	●	●	●	Set in units of 1 mm/s
	Position	[Position]: Target position [Pushing]: Pushing start position	●	●	●	Set in units of 0.01 mm
	Acceleration/Deceleration	Acceleration/deceleration during movement	●	●	●	Set in units of 1 mm/s ²
	Pushing force	Rate of force during pushing operation	●	●	●	Set in units of 1%
	Trigger LV	Target force during pushing operation	△	●	●	Set in units of 1%
	Pushing speed	Speed during pushing operation	△	●	●	Set in units of 1 mm/s
	Moving force	Force during positioning operation	△	●	●	Set to 100%
	Area output	Conditions for area output signal to turn ON	△	●	●	Set in units of 0.01 mm
	In position	[Position]: Width to the target position [Pushing]: How much it moves during pushing	△	●	●	Set to 0.5 mm or more (Units: 0.01 mm)
Parameter setting (Excerpt)	Stroke (+)	+ side position limit	×	×	●	Set in units of 0.01 mm
	Stroke (-)	- side position limit	×	×	●	Set in units of 0.01 mm
	ORIG direction	Direction of the return to origin can be set.	×	×	●	Compatible
	ORIG speed	Speed during return to origin	×	×	●	Set in units of 1 mm/s
	ORIG ACC	Acceleration during return to origin	×	×	●	Set in units of 1 mm/s ²
Test	JOG		●	●	●	Continuous operation at the set speed can be tested while the switch is being pressed.
	MOVE		×	●	●	Operation at the set distance and speed from the current position can be tested.
	Return to ORIG		●	●	●	Compatible
	Test drive	Operation of the specified step data	●	●	● (Continuous operation)	Compatible
	Forced output	ON/OFF of the output terminal can be tested.	×	×	●	Compatible
Monitor	DRV mon	Current position, speed, force, and the specified step data can be monitored.	●	●	●	Compatible
	In/Out mon	Current ON/OFF status of the input and output terminal can be monitored.	×	×	●	Compatible
ALM	Status	Alarm currently being generated can be confirmed.	●	●	●	Compatible
	ALM Log record	Alarms generated in the past can be confirmed.	×	×	●	Compatible
File	Save/Load	Step data and parameters can be saved, forwarded, and deleted.	×	×	●	Compatible
Other	Language	Can be changed to Japanese or English	●	●	●	Compatible

△: Can be set from TB Ver. 2.** (The version information is displayed on the initial screen.)

Fieldbus Network

EtherCAT/EtherNet/IP™/PROFINET Direct Input Type Step Motor Controller/JXC□H Series p. 38

ACT 2 Controller Setting Software
ACT Controller 2

Ether**CAT**™



JXCEH

Ether**Net/IP**™



JXC9H

PROFI
NET®



JXCPH

○ **Two types of operation command**

Step no. defined operation: Operate using the preset step data in the controller.

Numerical data defined operation: The actuator operates using values such as position and speed from the PLC.

○ **Numerical monitoring available**

Numerical information, such as the current speed, current position, and alarm codes, can be monitored on the PLC.

○ **Transition wiring of communication cables**

Two communication ports are provided.

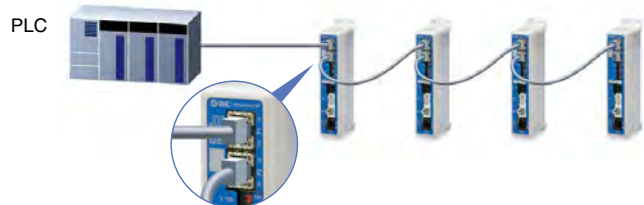

Application

Communication protocols

Ether**CAT**™
Ether**Net/IP**™
PROFI
NET®



Both air and electric systems can be established under the same protocol.

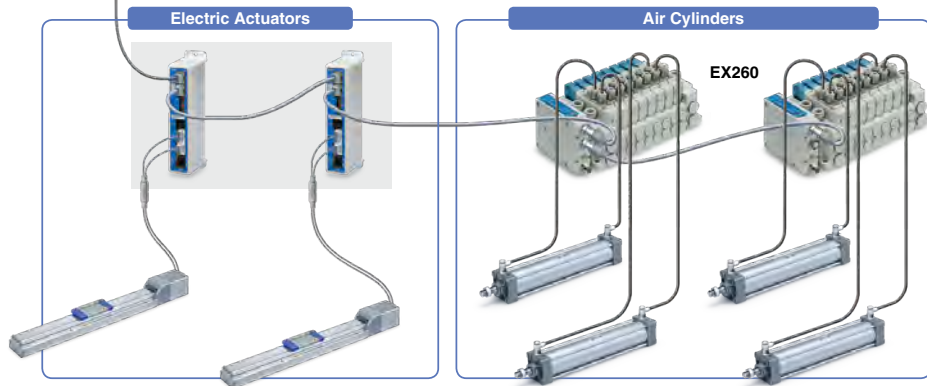

ACT 2

Controller Setting Software ACT Controller 2

From p. 3

Easy-to-use setting software ACT Controller 2 (For PC)

Various functions available in normal mode (Compared with the existing ACT Controller)

- Parameter and step data setting
- Alarm confirmation
- Waveform monitoring
- The JXC-BC writing tool
- Customizable plug-in functions

* Customers operating computers with specifications other than Windows 10/64 bit should use the existing ACT Controller.

System Construction/General Purpose I/O

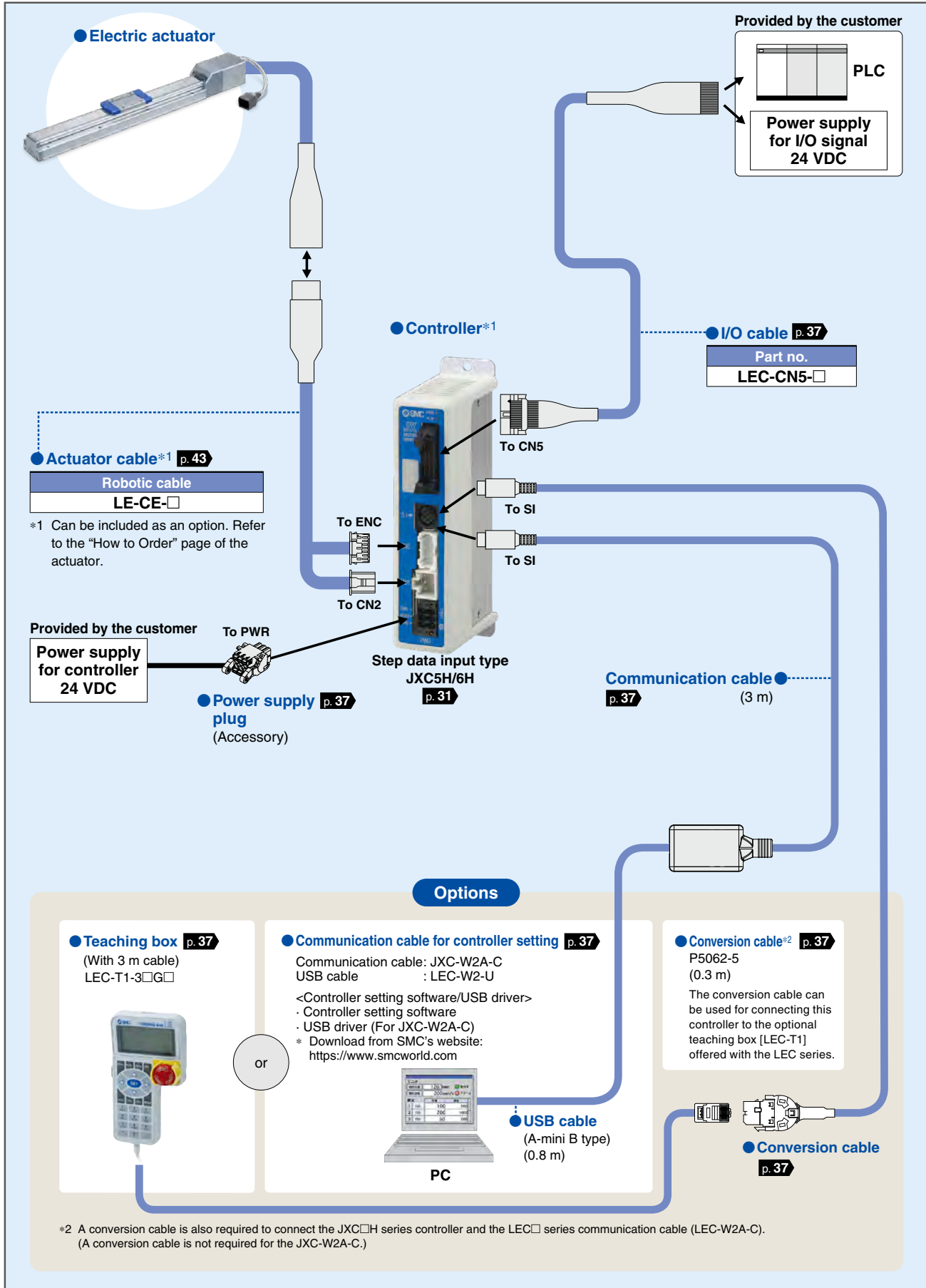

System Construction/Fieldbus Network (EtherCAT/EtherNet/IP™/PROFINET Direct Input Type)

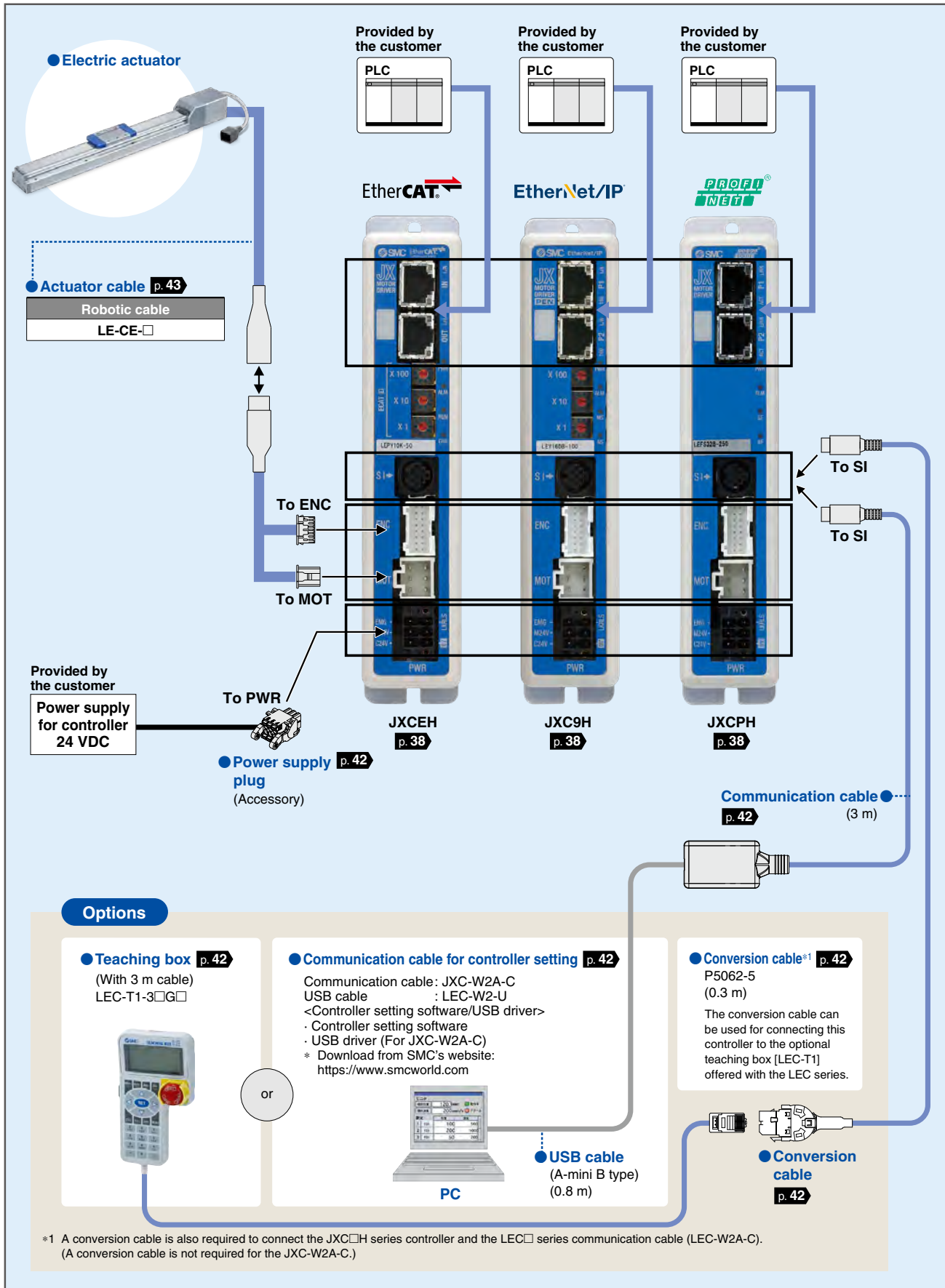

Battery-less Absolute (Step Motor 24 VDC)

High Performance

High Rigidity and High Precision Slider Type LEKFS□G Series LEKFS25, 32, 40



* For details, refer to page 45.



Model Selection

LEKFS□G Series

Auto Switch

JXC5H/6H Series

JXCEH/9H/PH Series

How to Order

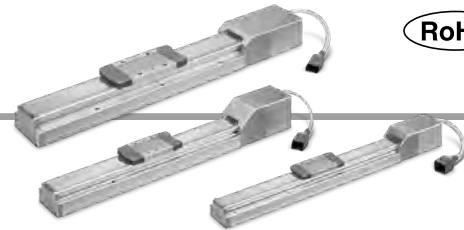

LEKFS **32** **G** **A** - **300** **R1** **C5H73**

① ② ③ ④ ⑤ ⑥ ⑦ ⑧ ⑨

① Size

25
32
40

② Motor mounting position

Nil	In-line
R	Right side parallel
L	Left side parallel

③ Motor type

G	High performance Battery-less absolute (Step motor 24 VDC)
---	--

④ Lead [mm]

Symbol	LEKFS25	LEKFS32	LEKFS40
H	20	24	30
A	12	16	20
B	6	8	10

⑤ Stroke*1

100	100
to	to
600	600

* For details, refer to the applicable stroke table below.

Applicable Stroke Table

Size	Stroke					
	100	200	300	400	500	600
25	●	●	●	●	●	—
32	●	●	●	●	●	—
40	—	●	●	●	●	●

⑥ Motor option

Nil	Without option
B	With lock

⑦ Grease application (Seal band part)

Nil	With
N	Without (Roller specification)

⑧ Actuator cable type/length

Robotic cable				[m]
Nil	None	R8	8*2	
R1	1.5	RA	10*2	
R3	3	RB	15*2	
R5	5	RC	20*2	

⑨ Controller

Nil	Without controller
C□H□□	With controller

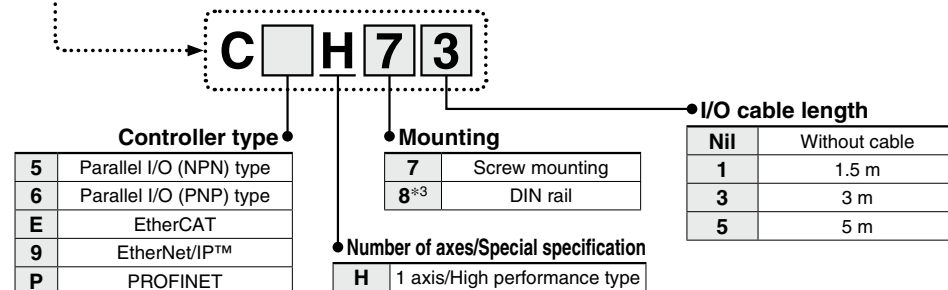

*1 Please contact SMC for non-standard strokes as they are produced as special orders.

*2 Produced upon receipt of order

*3 The DIN rail is not included. It must be ordered separately.

For auto switches, refer to pages 27 to 29.



Automation - Controls - Process



Leading global pneumatics and industrial automation components manufacturer dedicated to sustainable factory automation.

Serving the industries of semiconductor, food & packaging, life science, automotive, machine tool, process, natural resource, and general needs for automation, controls, and process.

Global Presence

- 532 Sales Offices in 83 Countries
- Production Facilities in 29 Countries & Regions
- Technical Centers in Japan, the U.S., Europe, & China

Extensive Product Line

- 12,000 Basic Models with over 700,00 Variations
 - Actuators
 - Sensors & Switches
 - Connectors
 - Process Gas
 - Electrical Products
 - Temperature Control
 - Vacuum
 - Valves
 - Air Preparation
 - Static Control
 - Chemical Handling
 - Specialty Products

North American Support

- 30 North American Locations
- Configure, Validate, & Download 3D & 2D Models from www.smcusa.com/products
- 2.6 Million sqft North American Headquarters of Engineering, Production, Central Distribution & Administration

Sales Offices

WEST	CENTRAL	EAST
Austin	Chicago	Atlanta
Dallas	Cincinnati	Birmingham
Denver	Cleveland	Boston
El Paso	Detroit	Charlotte
Los Angeles	Des Moines	Knoxville
Phoenix	Grand Rapids	Nashville
Portland	Indianapolis	New Jersey
San Jose	Kansas City	Rochester
	Milwaukee	Tampa
	Minneapolis	
	St. Louis	
CANADA		
Montreal		
Toronto		

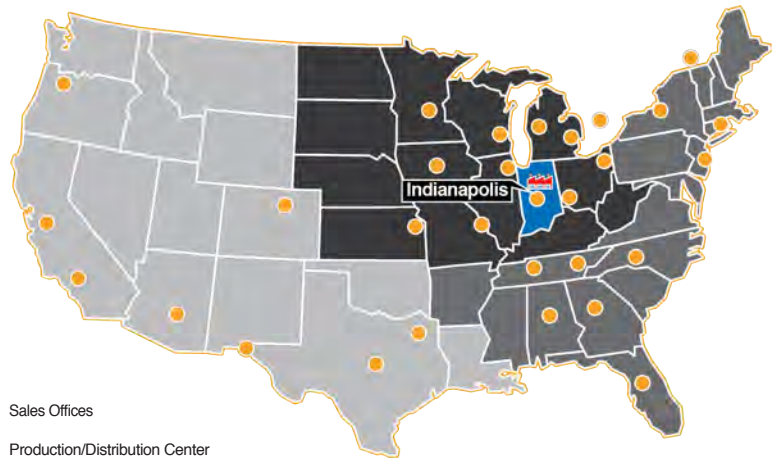

© 2023 SMC Corporation of America, All Rights Reserved. All reasonable efforts to ensure the accuracy of the information detailed in this catalog were made at the time of publishing. However, SMC can in no way warrant the information herein contained as specifications are subject to change without notice.

BP RRD 2.5M

Scan to view full catalog

