



2-Port Solenoid Valve

Direct Operated, Pilot Operated



Improved environmental resistance due to the stainless steel coil cover [IP67 enclosure/NEMA4X*1]

*1 IP65 for models with a DIN terminal

- High Flow and Energy Efficient
- Port Size 1/8" to 2"
- Standard M12 Connection

New A pilot operated steam type (JSXP series) has been added.



CO2 emissions (Power consumption)	Series	CO2 emissions [kg-CO2e/year]
71.4% reduction	Power Saving Type JSX31U Series	2.86 ← 71.4% reduction
	Existing model VX23 Series	10

<p>Direct Operated General Service JSX Series</p>	<p>Pilot Operated Zero Differential Pressure Type JSXZ Series</p>	<p>Direct Operated Vacuum Type JSX□□V Series</p>	<p>Direct Operated Modular Mounting Type JSXM Series</p>	<p>Direct Operated High Pressure Type JSX□□H Series</p>
<p>Direct Operated Steam Type JSX□□S Series</p>	<p>Direct Operated High Flow/ Power Saving Type JSX□□U Series</p>	<p>Pilot Operated General Service JSXD Series</p>	<p>Pilot Operated Steam Type JSXP Series</p>	

JSX Series

Automation
Controls
Process

Series Variations

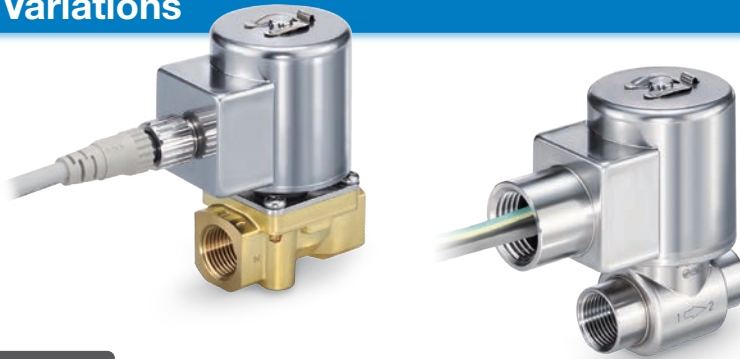

Direct Operated **JSX Series**

Model	Port size	Orifice diameter [mmø]	Flow rate*1 [L/min]				Fluid	Body material	Valve type	Seal material	Electrical entry	Standards
			5	10	20	30						
JSX10 Series *2	1/8	1.6 2.4	5	(For orifice diameter ø2.4)			Air Water Oil	Stainless steel Brass Aluminum	N.C. N.O.	NBR FKM EPDM	Grommet DIN terminal Conduit M12 connector	
JSX20 Series	1/8	3.2	15									
	1/4, 3/8	3.2, 4.0, 5.6, 7.1	(For orifice diameter ø5.6)									
JSX30 Series	1/4, 3/8	4.0, 5.6, 7.1	25				(For orifice diameters ø4.0 and ø5.6)					

*1 At the max. operating pressure differential (Fluid: Water)

*2 Excludes N.O.

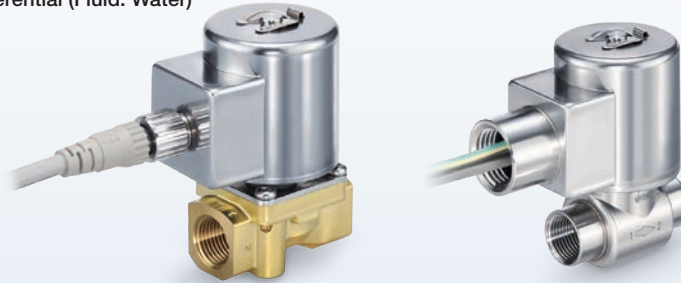

Direct Operated **High Flow/ Power Saving Type JSX□□U Series**

Model	Port size	Orifice diameter [mmø]	Flow rate*1 [L/min]				Fluid	Body material	Valve type	Seal material	Electrical entry	Standards
			5	10	20	30						
JSX10U Series	1/8	2.4	7				Air Water Oil	Stainless steel Brass	N.C.	NBR FKM EPDM	Grommet DIN terminal Conduit M12 connector	
JSX20U Series	1/4, 3/8	4.0	25									
		7.1	(For orifice diameter ø7.1)									
JSX30U Series	1/4, 3/8	7.1	35									

*1 At the max. operating pressure differential (Fluid: Water)

*2 Inquire about status of UL

Model	Port size	Orifice diameter [mmø]	Flow rate*1 [L/min] (ANR)				Fluid	Body material	Valve type	Seal material	Electrical entry	Standards
			500	1000	1500	2000						
JSX20U Series	1/4, 3/8	5.0	1000				Air	Aluminum	N.C.	NBR FKM EPDM	Grommet DIN terminal Conduit M12 connector	
JSX30U Series	1/4, 3/8	7.0	1700									

*1 At the max. operating pressure differential (Fluid: Water)

*2 Inquire about status of UL

Series Variations

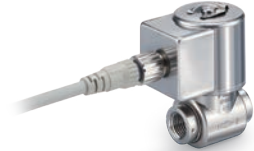

Direct Operated Vacuum Type JSX□□V Series

Model	Port size	Orifice diameter [mmø]	Flow rate*1 [L/min]				Fluid	Body material	Valve type	Seal material	Electrical entry	Standards
			200	500	700	1000						
JSX10V Series	1/8	1.6 2.4	190 (For orifice diameter ø2.4)				Air	Stainless steel Brass	N.C.	FKM	Grommet DIN terminal Conduit M12 connector	
JSX20V Series	1/8, 1/4, 3/8	3.2, 4 5.6, 7.1	470 (For orifice diameter ø4)									
JSX30V Series	1/4, 3/8	4 5.6, 7.1	940 (For orifice diameter ø5.6)									

*1 At the max. operating pressure differential (Fluid: Water)

*2 Inquire about status of UL

Direct Operated High Pressure Type JSX□□H Series

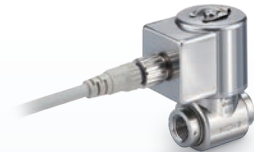

Model	Port size	Orifice diameter [mmø]	Flow rate*1 [L/min]						Fluid	Body material	Valve type	Seal material	Electrical entry	Standards
			500	750	1000	1500	2000	2250						
JSX30H Series	1/4, 3/8	3.2	2200						Air	Stainless steel Brass	N.C.	NBR FKM EPDM	Grommet DIN terminal Conduit M12 connector	

*1 At the max. operating pressure differential (Fluid: Water)

*2 Inquire about status of UL

Direct Operated Steam Type JSX□□S Series



Model	Port size	Orifice diameter [mmø]	Flow rate*1 [L/min]						Fluid	Body material	Valve type	Seal material	Electrical entry	Standards
			5	10	15	20	25	30						
JSX30S Series	1/4, 3/8	5.6, 7.1	15 (For orifice diameter ø5.6)						Air (Steam) Heated water	Stainless steel Brass	N.C.	FKM	Conduit terminal	

*1 At the max. operating pressure differential (Fluid: Water)

*2 Inquire about status of UL

Direct Operated Modular Mounting Type JSXM Series



Model	Port size	Orifice diameter [mmø]	Flow rate*1 [L/min] (ANR)		Fluid	Body material	Valve type	Seal material	Electrical entry	Standards
			500	1000						
JSXM20 Series	1/8, 1/4	3.2	650		Air	Aluminum	N.C.	NBR FKM	Grommet DIN terminal Conduit M12 connector	
JSXM30 Series	1/4, 3/8	4.0	1300							
JSXM40 Series	1/4, 3/8, 1/2	4.0	1300							

*1 At the max. operating pressure differential (Fluid: Water)

*2 Inquire about status of UL

Series Variations



Pilot Operated JSXD Series

Model	Port size	Orifice diameter [mmø]	Flow rate*1 [L/min]			Fluid	Body material	Valve type	Seal material	Electrical entry	Standards
			200	400	1000						
JSXD30 Series	1/4, 3/8, 1/2	10	100			Air Water Oil	Stainless steel Brass Bronze Aluminum	N.C. N.O.	NBR FKM EPDM	Grommet DIN terminal Conduit M12 connector	
JSXD40 Series	3/8, 1/2	15	200								
JSXD50 Series	3/4	20	430								
JSXD60 Series	1	25	580								
JSXD70 Series	1 1/4, 32A	35	1000								
JSXD80 Series	1 1/2, 40A	40	1400								
JSXD90 Series	2, 50A	50	2200								

*1 At the max. operating pressure differential (Fluid: Water)

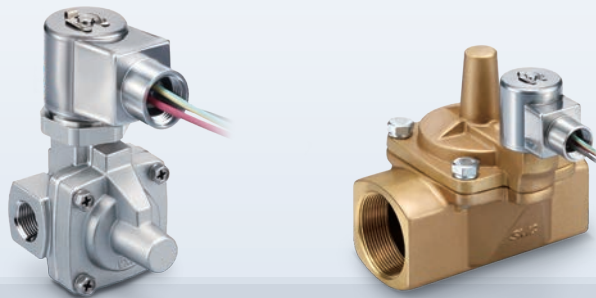

Pilot Operated Steam Type JSXP Series

Model	Port size	Orifice diameter [mmø]	Flow rate*1 [L/min]			Fluid	Body material	Valve type	Seal material	Electrical entry	Standards
			200	400	1000						
JSXP40 Series	3/8, 1/2	15	200			Steam Heated water	Stainless steel Brass Bronze	N.C. FKM PTFE	Grommet Conduit	 	
JSXP50 Series	3/4	20	420								
JSXP60 Series	1	25	530								
JSXP70 Series	1 1/4, 32A	35	1000								
JSXP80 Series	1 1/2, 40A	40	1400								
JSXP90 Series	2, 50A	50	2200								

*1 At the max. operating pressure differential (Fluid: Water)

*2 Inquire about status of UL

Series Variations

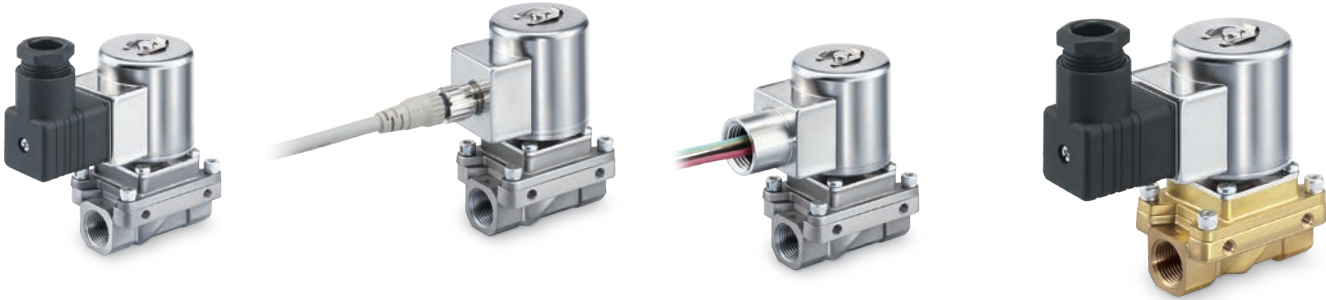

Zero Differential Pressure Type Pilot Operated **JSXZ Series**

Model	Port size	Orifice diameter [mm]	Flow rate*1 [L/min]			Fluid	Body material	Valve type	Seal material	Electrical entry	Standards
			200	400	1000						
JSXZ30 Series	1/4, 3/8	10	100			Air Water Oil	Stainless steel Brass Aluminum	N.C.	NBR FKM EPDM	Grommet DIN terminal Conduit M12 connector	
JSXZ40 Series	1/2	15	200								
JSXZ50 Series	3/4	20	400								
JSXZ60 Series	1	25	460								

*1 At the max. operating pressure differential (Fluid: Water)
*2 Inquire about status of UL

Type

Direct Operated



JSX Series

Pilot Operated



JSXD Series

Zero Differential Pressure Type Pilot Operated



JSXZ Series

Electrical entry

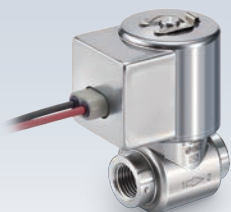

Grommet with PCB



Conduit



DIN terminal



M12 connector

SPACE SAVING

COMPACT
Valve volume: **25% reduction***1

LIGHTWEIGHT
Weight: **30% reduction***1
*1 Compared with the existing model

Energy saving*3

Coil force: **10% increase**
(Compared with the existing model)
Power consumption: **14% reduction**
(Compared with the existing model)
The coil attraction force has been improved by 10% and the power consumption has been reduced by 14% for optimal magnetic efficiency.

*3 For JSX series N.C./DC specification valves

360° lead wire insertion and removal is possible.

As the coil rotates 360°, the lead wire is easy to handle.

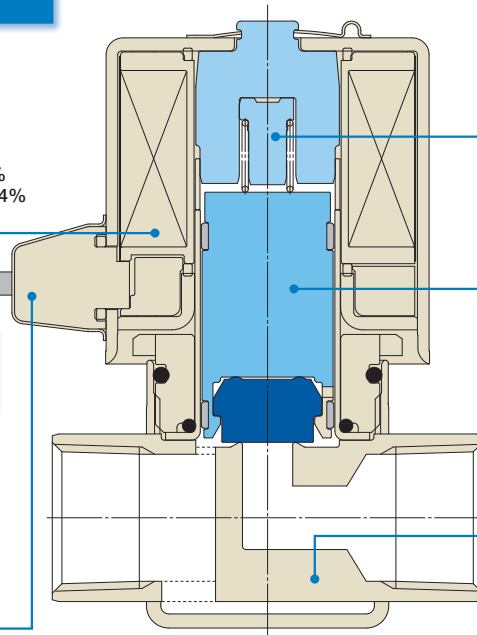

Stopper construction

Metal noise reduced by the resin stopper
Longer service life

Improved armature durability

IP67 enclosure

* IP65 for models with a DIN terminal

Choice of body material

- Stainless steel
 - Aluminum
 - Brass/Bronze^{*2}
- *2 The bronze body is only selectable for the pilot operated type, (port sizes 1" to 2")

Power consumption * For DC voltages

Model	Size	10	20	30	40	50	60	70	80	90
Direct Operated JSX Series		4	6	8	—	—	—	—	—	—
Direct Operated High Flow/ Power Saving Type JSX□□U Series		2*1	3*1	3*1	—	—	—	—	—	—
Direct Operated Vacuum Type JSX□□V Series		4	6	8	—	—	—	—	—	—
Direct Operated Steam Type JSX□□S Series		—	—	13	—	—	—	—	—	—
Direct Operated High Pressure Type JSX□□H Series		—	—	13	—	—	—	—	—	—
Pilot Operated JSXD Series		—	—	6	6	6	8	8	8	8
Pilot Operated Steam Type JSXP Series		—	—	—	6	6	8	8	13	13
Zero Differential Pressure Type Pilot Operated JSXZ Series		—	—	8	8	13	13	—	—	—
Modular Mounting Type JSXM Series		—	6	8	8	—	—	—	—	—

*1 When holding in an energized state

Full-wave rectifier type

- **Improved durability**
Extended service life due to the special construction (Compared with the existing shading coil)
- **Reduced buzzing noise**
Due to being rectified to DC by the full-wave rectifier
- **Reduced apparent power**
* Class B, N.C. valve (Compared with the existing model)
9.5 VA ▶ **8 VA** (JSX20/JSXD60, 70 Series)
12 VA ▶ **9.5 VA** (JSX30/JSXD80, 90 Series)

- **Improved OFF response**
Specially constructed to improve the OFF response when operated with high viscosity fluids such as oil
- **Low-noise construction**
Specially constructed to reduce metal noise during operation

Flow rate increasable by up to 86%*1

High Flow/ Power Saving Type JSX□□U Series

*1 Operating pressure: 0.9 MPa

	Orifice diameter [mmφ]	Flow rate [L/min]	
		5	10
High Flow/ Power Saving Type JSX11U Series	2.4	6.5	86% increase
JSX11 Series	1.6	3.5	

Reduced valve size*1

*1 Max. flow rate: 23.9 L/min, Orifice diameter: φ4 mm, Max. operating pressure differential: 1.0 MPa

JSX21U Series < JSX31 Series

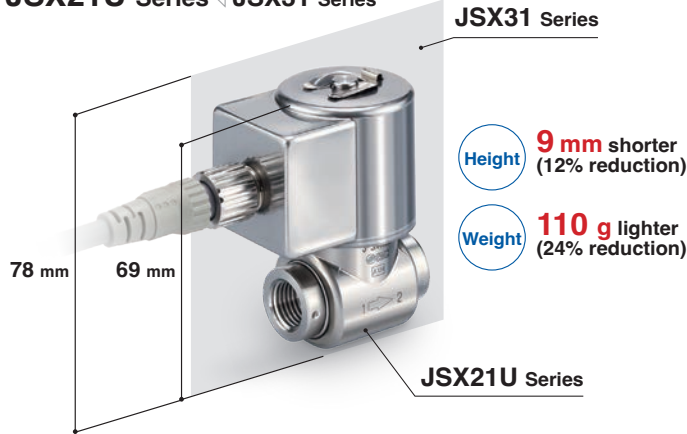

	Height [mm]	Weight [g]
JSX21U Series	69	340
JSX31 Series	78	450

Substantial holding power consumption reduction

The overall power consumption amount can be reduced by up to **63%** by reducing the power consumption during holding.

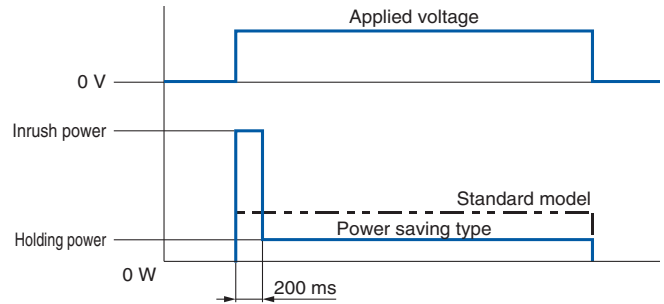

* Effective after being energized for more than 200 ms

Power Consumption (Holding)

[W]

	Size 10	Size 20	Size 30
JSX□□U Series	2	3	3
JSX□□ Series	4	6	8

Modular Mounting Type JSXM Series

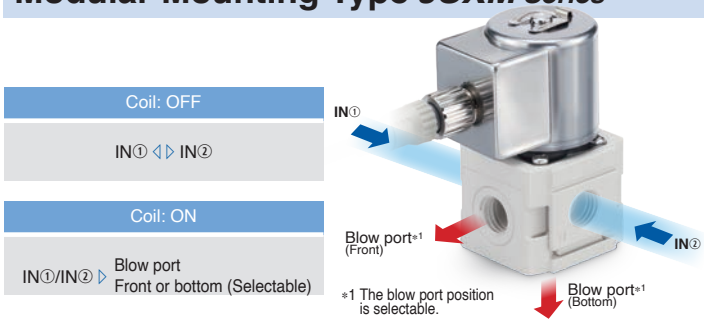

Can be connected to modular type F.R.L. units

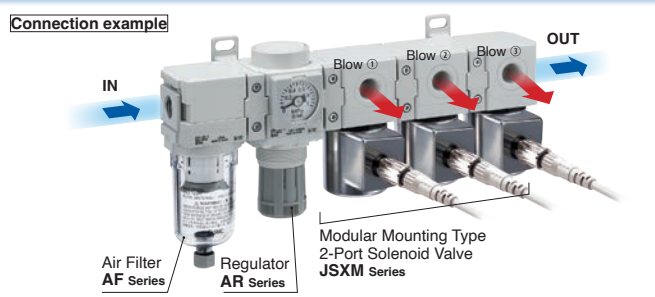

Simple Specials System

Short lead times

This system enables us to respond to your special needs (additional machining, accessory assembly, or the designing of a modular unit) and deliver your personalized products as quickly as standard products.

A system designed to respond quickly and easily to your special ordering needs. For modular connection units (shipped assembled), the simple specials system can be used.

Repeat orders

Once we receive a simple special part number from one of your previous orders, we will process the order, manufacture the product, and deliver it to you as quickly as possible.

Please contact your local sales representative for more details.

The coil orientation and blow port position can be selected.

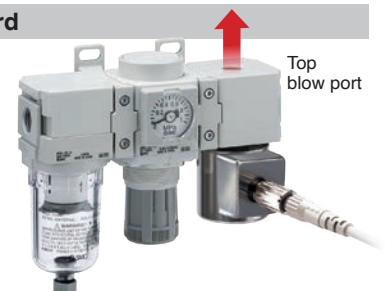
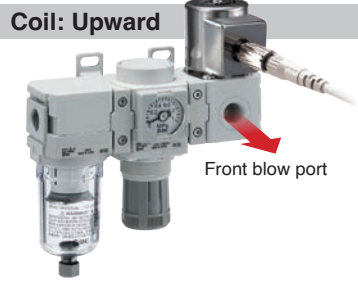

Related Product

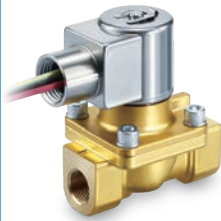

High Pressure Solenoid Valve, 4 MPa JSXH-X1 Series

- High-pressure application up to 4 MPa (580 psi)
- Blow molding, Laser Processing, Nitrogen Filling
- Fluid: Air, Nitrogen, Argon, Oxygen
- Easy maintenance
- Port size: 3/8" & 1/2"



Solenoid Valve for High Pressure Water, 10 MPa

JSXH-X2 Series

- High-pressure water up to 10 MPa (1450 psi)
- High-pressure washing, water spraying and misting
- Fluid: Water
- IP67 enclosure & Stainless-steel coil cover
- Port size: 3/8" & 1/2"



Proportional Control Valve JSP Series

- Smooth flow rate control using current
- Flow control of shielding gas in welding, air purge, water temperature control
- Flow rate: 300 L/min (air), 3 L/min (water)
- Port size: 1/8", 1/4" & 3/8"

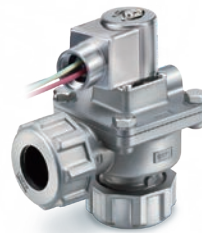

Dust Collector Reverse Pulse Jet Valve JSXF Series

- Long service life of 10 million cycles or more
- High peak pressure and low air consumption
- Threaded, Compression Fitting and Immersion Type
- Available in remote pilot type, integral pilot type and SMARTVENT™ type



Dust Collector Reverse Pulse Jet Valve JSXF SmartVent Series

- Integrated control board that can control up to 32 units
- Sends signal to base valve to initiate a cleaning cycle for all connected remote valves if clogging detected
- 10-step ON time setting (100 to 234 ms) and 16-step OFF time setting (4 to 29 s), pulse sequence order can be changed.
- Temperature range (-40 to 60°C)



Angle Seat Valve, Air Operated JSB Series

- Robust design featuring stainless steel body, scraper and guide bushing
- 10 million cycles (air, water), 3 million cycles (steam)
- Cv Flow Factor: 5 to 87.5
- Fluid: Air, Water, Steam
- Port size: 3/8" to 2"



2 Port Solenoid Valve for Drinking Water HF3-JSX Series

- For use in drinking water systems, certified to meet NSF/ANSI 61 standards
- Stainless-steel body for superior corrosion and water resistance
- Low power consumption
- Port size: 1/8", 1/4" & 3/8"

