



# Low Profile Air Gripper

ø8, ø12, ø16, ø20



## Height dimension reduced to approximately **1/3** with the same gripping force as the MHZ2-20

72.8 mm  $\triangleright$  **25 mm**

(Comparison with our MHZ2 Series equivalent gripping force products)

**MHF2-12D**



25 mm

**MHZ2-20D3**

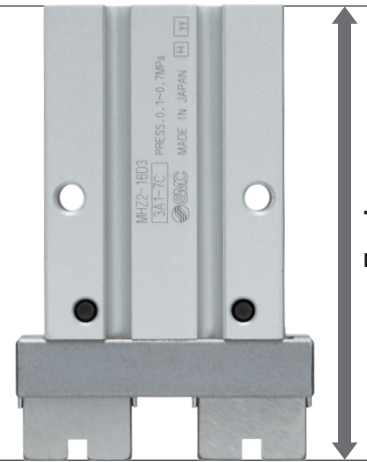

72.8 mm

Reduced by **47.8 mm**

### Linear guide

High precision and high rigidity

### 3 types of stroke lengths are available.

The stroke can be selected according to the workpiece.

Short stroke	Medium stroke	Long stroke
8 to 20 mm	16 to 40 mm	32 to 80 mm

**New**

An actuator position sensor compatible type has been added.

p. 35, 36

The stroke position is output with an analog signal.

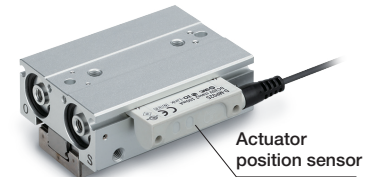

Actuator position sensor



## MHF2 Series

NC520A  
(ES20-166B)

# Compact

## Height: **66%** reduction

72.8 mm  $\triangleright$  **25 mm** (Comparison between the MHF2 ( $\phi 12$ ) and the MHZ2 ( $\phi 20$ ))

[mm]	
Bore size	Height
8	19
12	25
16	33
20	41

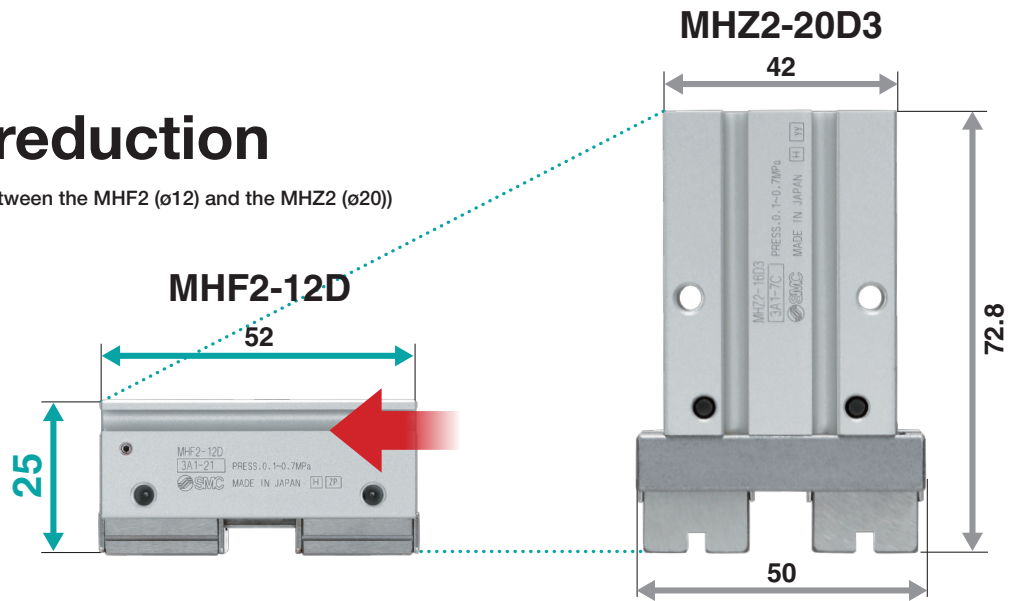

- Space-saving low-profile design
- Reduced moment generation
- Improved accuracy with smooth operation

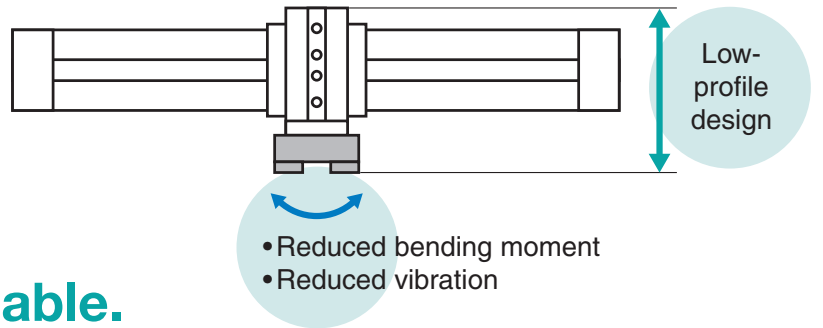

## Stroke selection is available.

3 standard stroke lengths are available for each bore size. The stroke can be selected according to the workpiece.

	$\phi 8$	$\phi 12$	$\phi 16$	$\phi 20$
Short	8 mm	12 mm	16 mm	20 mm
Medium	16 mm	24 mm	32 mm	40 mm
Long	32 mm	48 mm	64 mm	80 mm

### Actuator Position Sensor Compatible Type

Made to Order -X7050 p. 35, 36

- The stroke position is output with an analog signal.
- Repeatability: 0.1 mm
- Direct mounting is possible.



\*1 Actuator position sensor only



### Application Example

For the measurement of workpieces

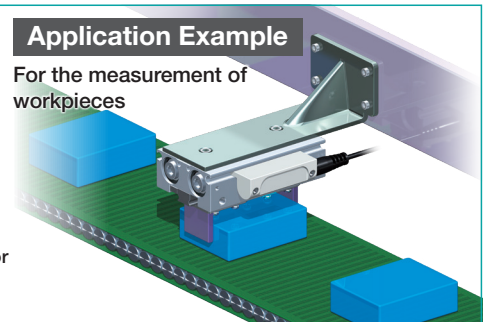

Auto switches can be mounted on both sides.

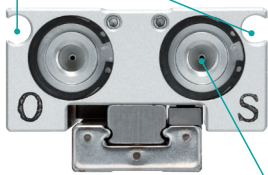

**Piping is possible from 2 directions.**

The piping port position can be specified using a part number.

**Linear guide**

High precision and high rigidity  
Uses martensitic stainless steel

**Easy positioning for mounting attachments**

With positioning pin holes



**Improved mounting repeatability**

With positioning pin holes

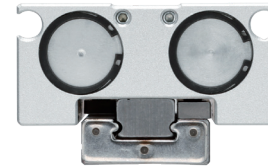

Centralized wiring and piping are possible.

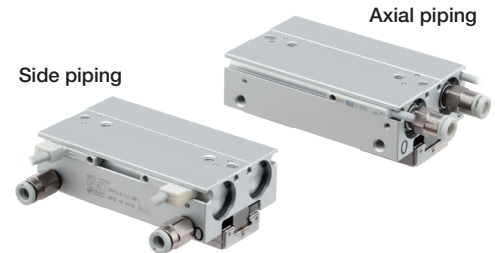

## High degree of mounting flexibility

As no brackets are required, the mounting height can be minimized.

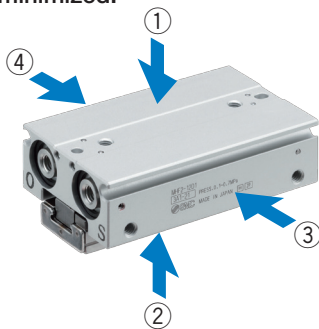

Mounting is possible from 4 directions.  
Axial piping: ①②③④  
Side piping: ①②④

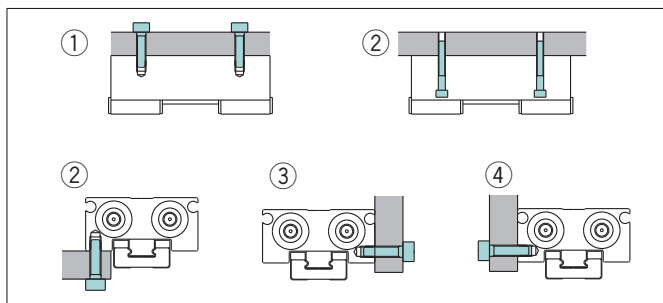

## Strong gripping force

The double piston construction allows for a compact design with strong gripping force.

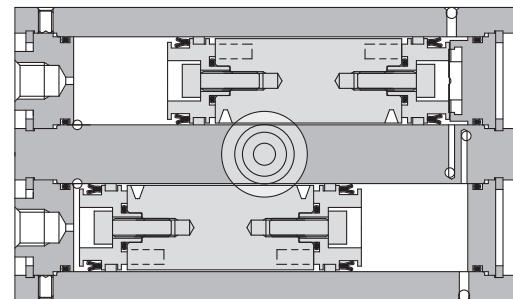

Model	Bore size	Gripping force [N]
MHF2-8D□	8	19
MHZ2-10D□	10	11
MHF2-12D□	12	48
MHZ2-20D□	20	42
MHF2-16D□	16	90
MHZ2-25D□	25	65
MHF2-20D□	20	141
MHZ2-32D□	32	158

## CONTENTS

Model Selection .....	p. 3
How to Order .....	p. 7
Specifications .....	p. 8
Construction .....	p. 9
Dimensions .....	p. 11
Body Option: Side Piping Type .....	p. 23

Auto Switch Installation Examples and Mounting Positions .....	p. 24
Prior to Use	
Auto Switch Connections and Examples .....	p. 27
Made to Order .....	p. 28
Specific Product Precautions .....	p. 37
Safety Instructions .....	Back cover

# MHF2 Series

## Model Selection

### Model Selection

#### Selection Procedure

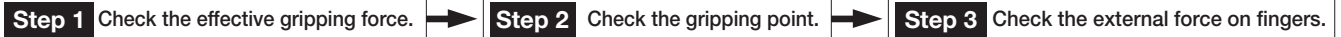

#### Step 1 Check the gripping force.



#### Example

Workpiece mass:  
0.15 kg

Gripping method:  
External gripping

#### Guidelines for the selection of the gripper with respect to workpiece mass

- Although conditions differ according to the workpiece shape and the coefficient of friction between the attachments and the workpiece, select a model that can provide a gripping force of at least 10 to 20 times\*1 greater than the workpiece weight.  
\*1 For further details, refer to the model selection illustration.
- Further allowance should be provided when great acceleration or impact is expected during workpiece transfer.

#### Calculation example

For setting the gripping force to be at least 20 times greater than the workpiece weight:  
Required gripping force = 0.15 kg x 20 x 9.8 m/s<sup>2</sup> ≈ 29.4 N or more

Gripping point distance:  
30 mm

Operating pressure:  
0.4 MPa

#### MHF2-12D

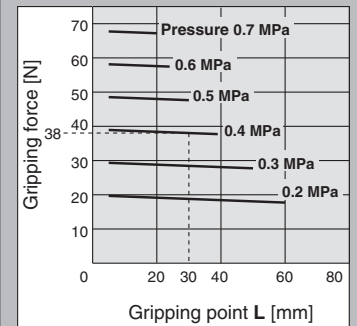

#### When the MHF2-12D is temporarily selected

- The gripping force is obtained from the intersection point of the gripping point L = 30 mm and a pressure of 0.4 MPa. Gripping force [N] = 38 N
- A gripping force of 38 N satisfies the required gripping force of 29.4 N. Therefore, the selection of MHF2-12D is appropriate.

#### Model Selection Illustration

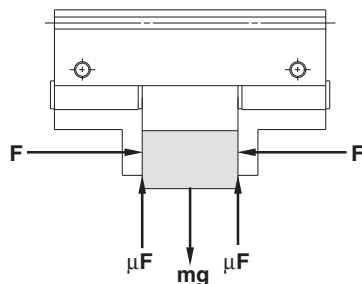

“Gripping force at least 10 to 20 times greater than the workpiece weight”

“At least 10 to 20 times greater than the workpiece weight” recommended by SMC is calculated with a margin of “a” = 4, which allows for impacts that occur during normal transportation, etc.

When $\mu = 0.2$	When $\mu = 0.1$
$F = \frac{mg}{2 \times 0.2} \times 4$	$F = \frac{mg}{2 \times 0.1} \times 4$
$= 10 \times mg$	$= 20 \times mg$

10 x Workpiece weight

20 x Workpiece weight

When gripping a workpiece as in the figure to the left, and with the following definitions,

F: Gripping force [N]

$\mu$ : Coefficient of friction between the attachments and the workpiece

m: Workpiece mass [kg]

g: Gravitational acceleration (= 9.8 m/s<sup>2</sup>)

mg: Workpiece weight [N]

the conditions under which the workpiece will not drop are

$$2 \times \mu F > mg$$

Number of fingers

and therefore,

$$F > \frac{mg}{2 \times \mu}$$

With “a” representing the margin,

“F” is determined by the following formula:

$$F = \frac{mg}{2 \times \mu} \times a$$

- \* Even in cases where the coefficient of friction is greater than  $\mu = 0.2$ , for reasons of safety, select a gripping force which is at least 10 to 20 times greater than the workpiece weight, as recommended by SMC.
- If high acceleration, or impact forces are encountered during motion, a further margin should be considered.

## Step 1 Check the effective gripping force: MHF2 Series

- Indication of effective gripping force  
The gripping force shown in the graphs below represents the gripping force of one finger when all fingers and attachments are in contact with the workpiece.  
F = One finger thrust
- Both the external and internal gripping forces are the values shown in the graphs below.

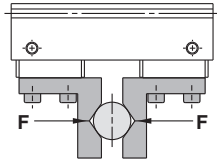

External gripping state

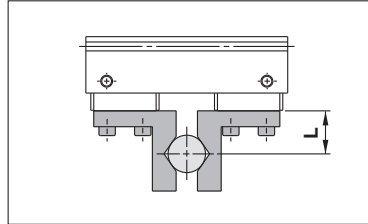

Internal gripping state

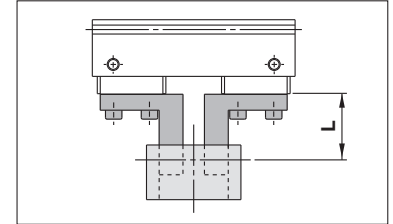

**MHF2-8D** □

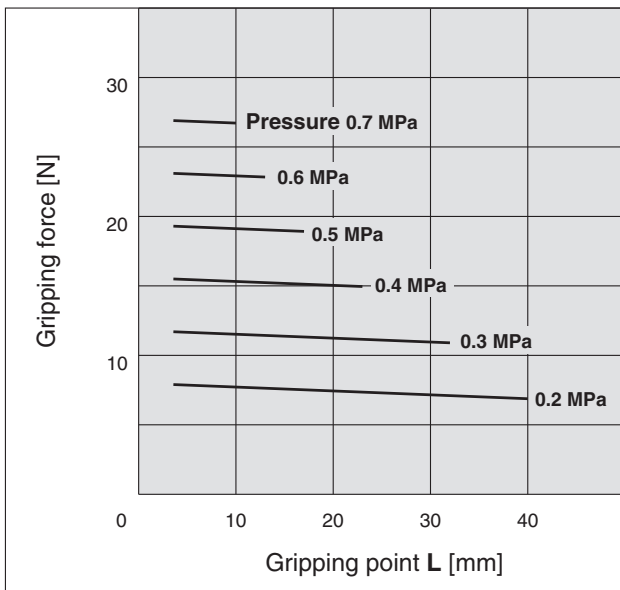

**MHF2-12D** □

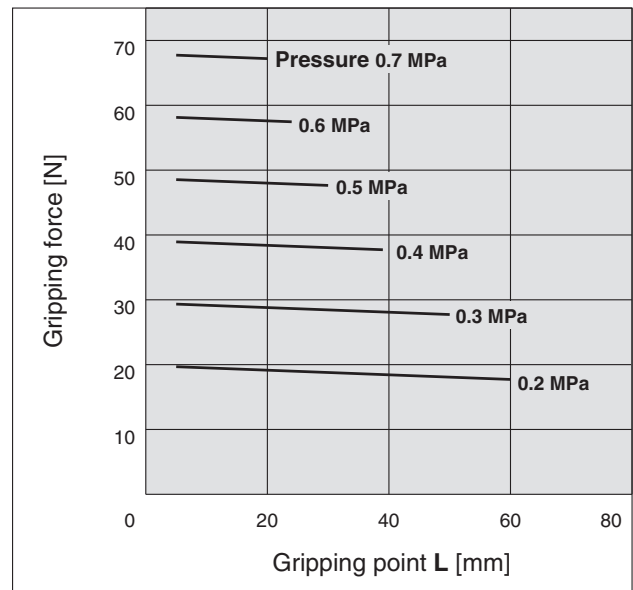

**MHF2-16D** □

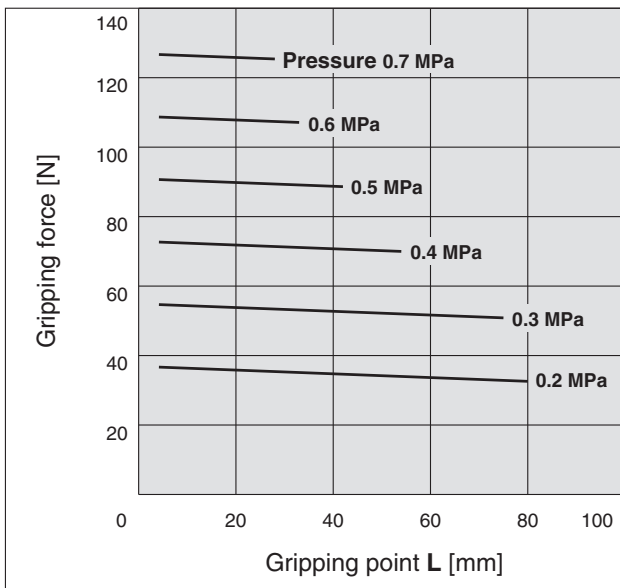

**MHF2-20D** □

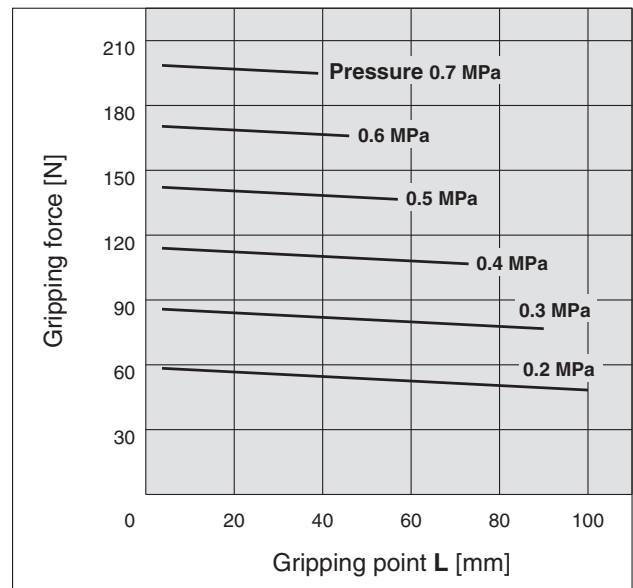

# MHF2 Series

## Model Selection

### Step 2 Check the gripping point: MHF2 Series

#### External gripping state

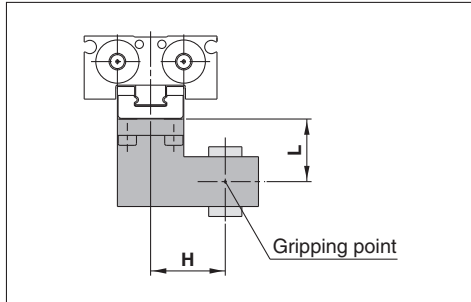

#### Internal gripping state

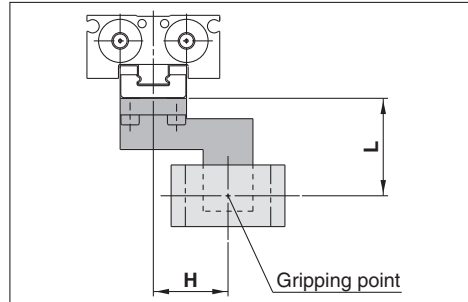

- The air gripper should be operated so that the workpiece gripping point "L" and the amount of overhang "H" stay within the range shown for each operating pressure given in the graphs below.
- If the workpiece gripping point goes beyond the range limits, this will have an adverse effect on the life of the air gripper.

MHF2-8D□

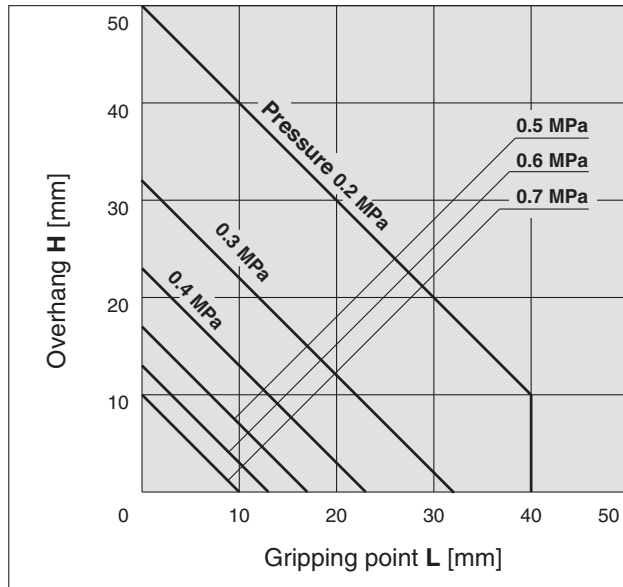

MHF2-12D□

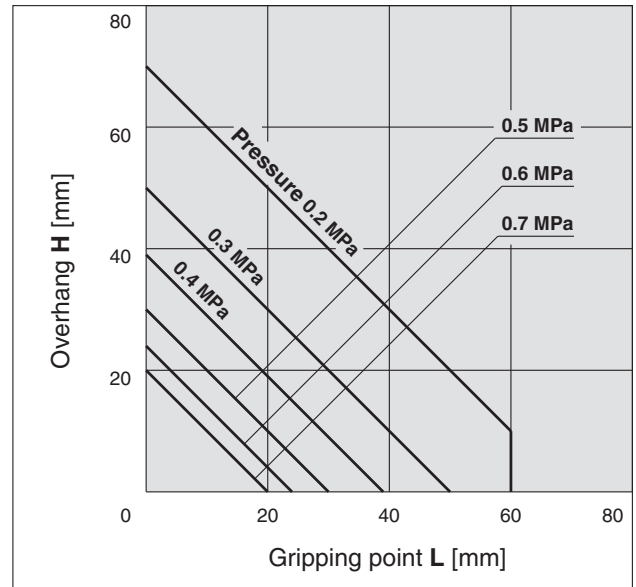

MHF2-16D□

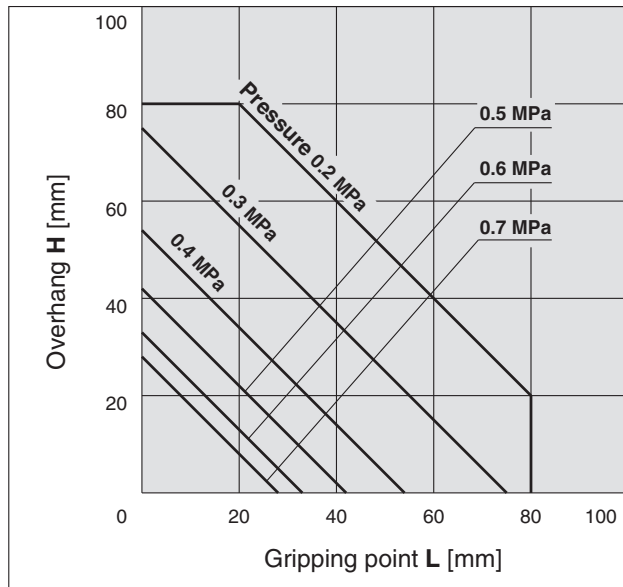

MHF2-20D□

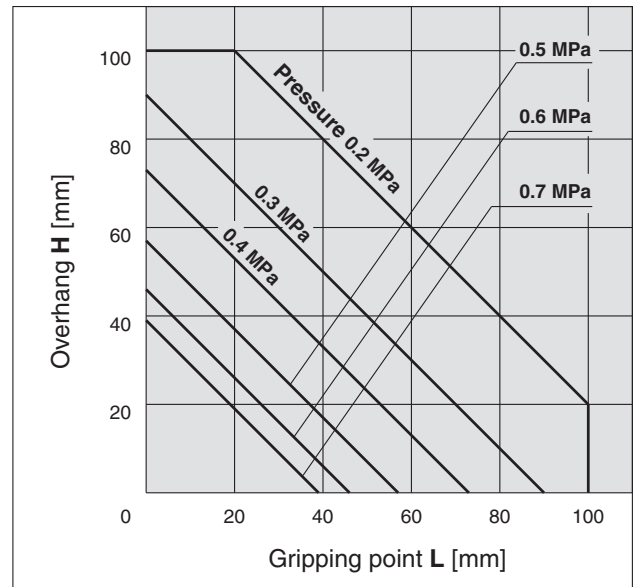

**Step 3** Check the external force on fingers: MHF2 Series

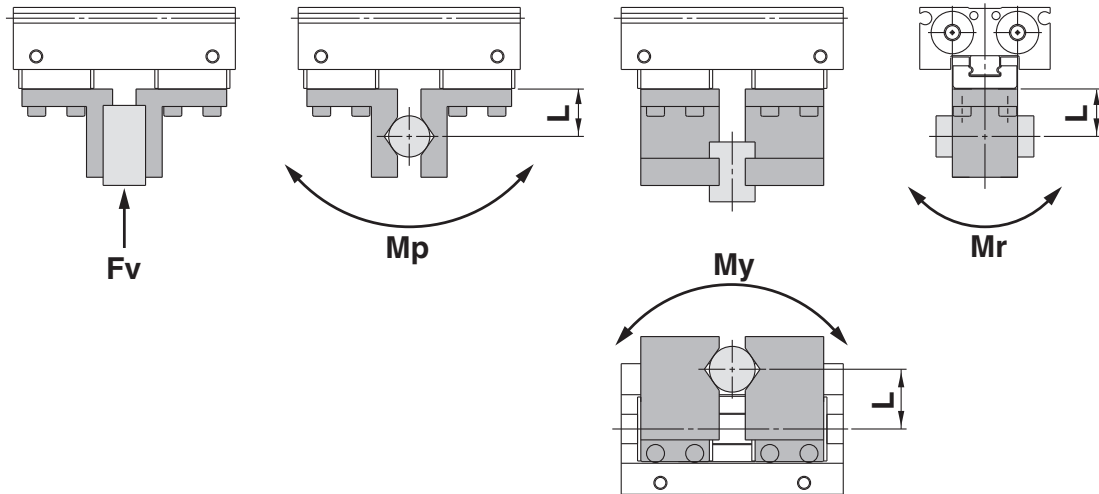

L: Distance to the point at which the load is applied [mm]

Model	Allowable vertical load Fv [N]	Max. allowable moment		
		Pitch moment Mp [N·m]	Yaw moment My [N·m]	Roll moment Mr [N·m]
MHF2-8D□	58	0.26	0.26	0.53
MHF2-12D□	98	0.68	0.68	1.4
MHF2-16D□	176	1.4	1.4	2.8
MHF2-20D□	294	2	2	4

\* The load and moment values in the table indicate static values.

Calculation of allowable external force (when moment load is applied)	Calculation example
$\text{Allowable load } F \text{ [N]} = \frac{M \text{ (Max. allowable moment) [N·m]}}{L \times 10^{-3 \cdot 1}}$ <p>(*1 Constant for unit conversion)</p>	<p>When a load <math>f = 10 \text{ N}</math> is operating, which applies pitch moment to point <math>L = 30 \text{ mm}</math> from the end of the MHF2-12D finger.</p> $\text{Allowable load } F = \frac{0.68}{30 \times 10^{-3}}$ $= 22.7 \text{ [N]}$ <p>Load <math>f = 10 \text{ [N]} &lt; 22.7 \text{ [N]}</math> Therefore, it can be used.</p>

# MHF2 Series

ø8, ø12, ø16, ø20



## How to Order

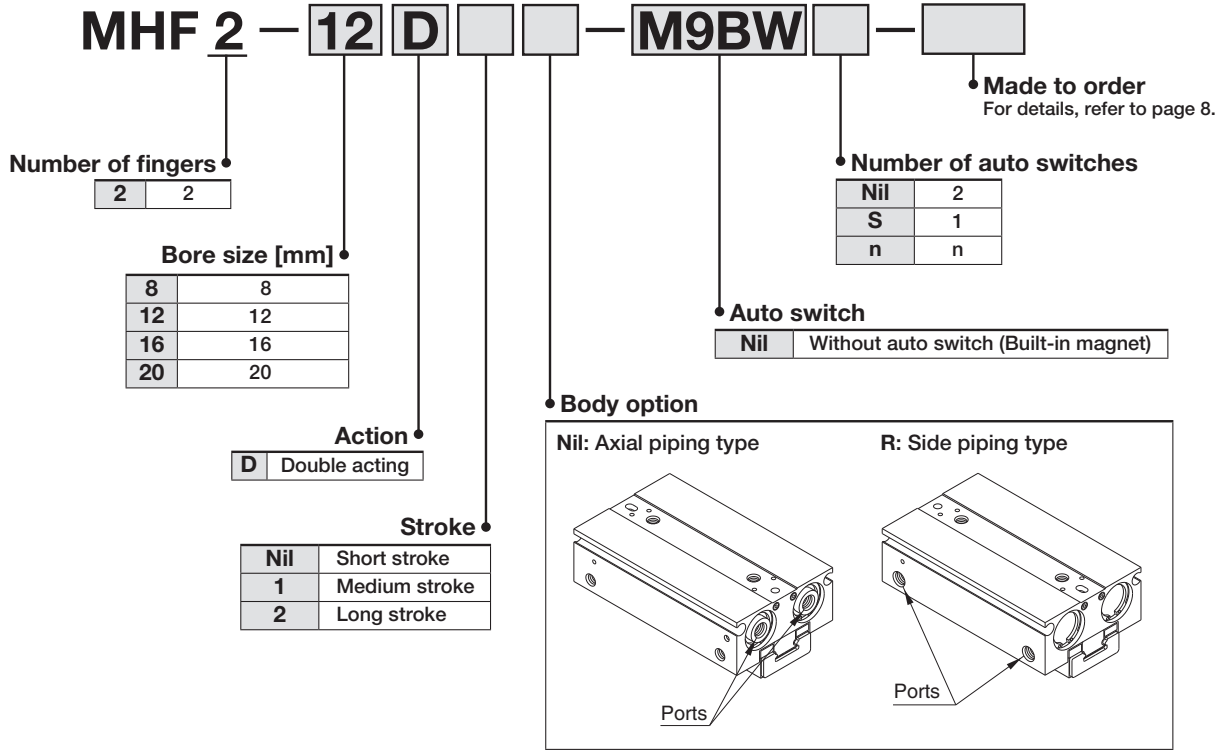

**Applicable Auto Switches**/Refer to the **Web Catalog** for further information on auto switches.

Type	Special function	Electrical entry	Indicator light	Wiring (Output)	Load voltage		Auto switch model		Lead wire length [m] <sup>*2</sup>				Pre-wired connector	Applicable load		
					DC	AC	Perpendicular	In-line	0.5 (Nil)	1 (M)	3 (L)	5 (Z)				
Solid state auto switch	—	Grommet	Yes	3-wire (NPN)	24 V	5 V, 12 V	—	M9NV	M9N	●	●	●	○	○	IC circuit	Relay, PLC
				3-wire (PNP)				M9PV	M9P	●	●	●	○	○		
				2-wire				M9BV	M9B	●	●	●	○	○		
				3-wire (NPN)				M9NVV	M9NV	●	●	●	○	○		
	Diagnostic indication (2-color indicator)			3-wire (PNP)	5 V, 12 V	M9PVV	M9PV	●	●	●	○	○	○	IC circuit		
				2-wire		M9BWV	M9BW	●	●	●	○	○	○	—		
	Water resistant (2-color indicator)			3-wire (NPN)	5 V, 12 V	M9NAV <sup>*1</sup>	M9NA <sup>*1</sup>	○	○	●	○	○	○	IC circuit		
				3-wire (PNP)		M9PAV <sup>*1</sup>	M9PA <sup>*1</sup>	○	○	●	○	○	○	—		
				2-wire		M9BAV <sup>*1</sup>	M9BA <sup>*1</sup>	○	○	●	○	○	○	—		
				2-wire		M9BAV <sup>*1</sup>	M9BA <sup>*1</sup>	○	○	●	○	○	○	—		

<sup>\*1</sup> Water-resistant type auto switches can be mounted on the above models, but SMC cannot guarantee water resistance.

<sup>\*2</sup> Lead wire length symbols: 0.5 m..... Nil (Example) M9NW  
 1 m..... M (Example) M9NWM  
 3 m..... L (Example) M9NWL  
 5 m..... Z (Example) M9NWZ

<sup>\*</sup> Solid state auto switches marked with a “○” are produced upon receipt of order.

<sup>\*</sup> When using the 2-color indicator type, please make the setting so that the indicator is lit in red to ensure the detection at the proper position of the air gripper.



## Specifications

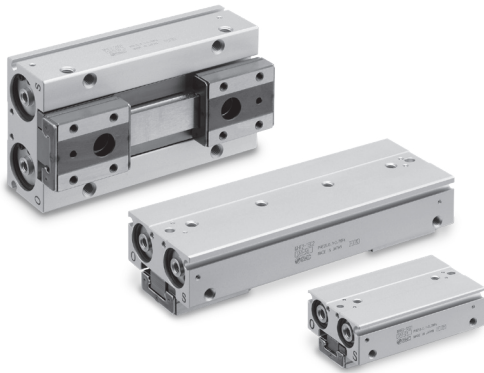

Fluid		Air
Operating pressure	ø8: 0.15 to 0.7 MPa	
	ø12 to 20: 0.1 to 0.7 MPa	
Ambient and fluid temperatures		-10 to 60°C (No freezing)
Repeatability		±0.05 mm <sup>*1</sup>
Max. operating frequency	Short stroke	120 c.p.m.
	Medium stroke	120 c.p.m.
	Long stroke	60 c.p.m.
Lubrication		Non-lube
Action		Double acting
Auto switch (Option) <sup>*2</sup>		Solid state auto switch (3-wire, 2-wire)

\*1 This is the value when no offset load is applied to the finger.

When an offset load is applied to the finger, the max. value is ±0.15 mm due to the influence of backlash of the rack and pinion.

\*2 Refer to the Web Catalog for further information on auto switches.

## Symbol

Double acting:  
Internal grip

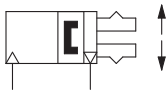

Double acting:  
External grip



## Model

Action	Model	Bore size [mm]	Gripping force <sup>*1</sup>		Opening/closing stroke (Both sides) [mm]	Weight <sup>*2</sup> [g]	Internal volume [cm <sup>3</sup> ]	
			Effective gripping force per finger [N]				Finger open side	Finger close side
Double acting	MHF2-8D	8	19		8	65	0.7	0.6
	MHF2-8D1				16	85	1.1	1.0
	MHF2-8D2				32	120	2.0	1.9
	MHF2-12D	12	48		12	155	1.9	1.6
	MHF2-12D1				24	190	3.3	3.0
	MHF2-12D2				48	275	6.1	5.8
	MHF2-16D	16	90		16	350	4.9	4.1
	MHF2-16D1				32	445	8.2	7.4
	MHF2-16D2				64	650	14.9	14.0
	MHF2-20D	20	141		20	645	8.7	7.3
	MHF2-20D1				40	850	15.1	13.7
	MHF2-20D2				80	1,225	28.0	26.6

\*1 At the pressure of 0.5 MPa, when gripping point L is 20 mm

\*2 Excluding the auto switch weight



**Made to Order**

(For details, refer to pages 28 to 36.)

Symbol	Specifications
-X4	Heat resistant (-10 to 100°C)
-X5	Fluororubber seal
-X50	Without magnet
-X53	Ethylene propylene rubber seal (EPDM)
-X63	Fluorine grease
-X79	Grease for food processing machines: Fluorine grease
-X79A	Grease for food processing machines: Aluminum complex soap base grease
-X81A	Anti-corrosive treatment of finger
-X81B	Anti-corrosive treatment of finger and guide
-X83	With an adjustable opening/closing finger positioning
-X7050	Actuator position sensor compatible type

## Moisture Control Tube IDK Series



When operating an actuator with a small bore size and a short stroke at a high frequency, dew condensation (water droplets) may occur inside the piping depending on the conditions.

Simply connecting the moisture control tube to the actuator will prevent dew condensation from occurring. For details, refer to the IDK series in the Web Catalog.

# MHF2 Series

## Construction

### MHF2-8D, MHF2-8D1

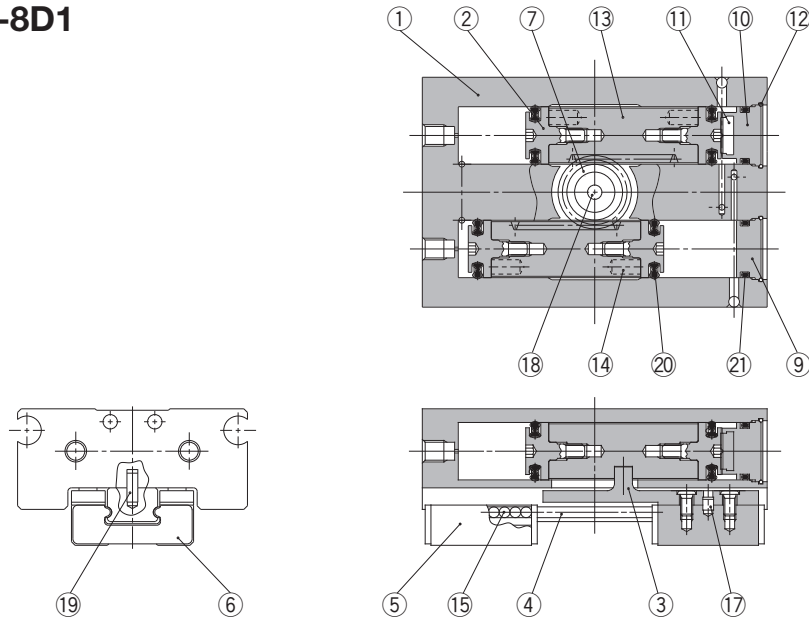

### MHF2-8D2

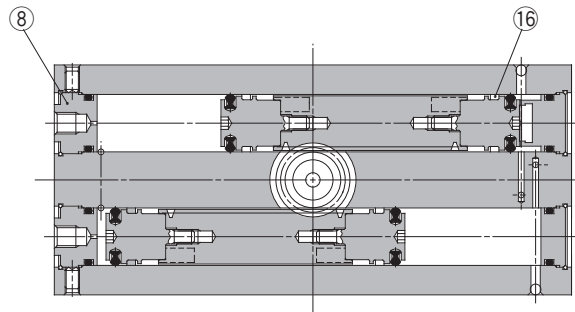

### Component Parts

No.	Description	Material	Note
1	Body	Aluminum alloy	Hard anodized
2	Piston	Stainless steel	
3	Joint	Stainless steel	Heat treatment
4	Guide rail	Stainless steel	Heat treatment
5	Finger	Stainless steel	Heat treatment
6	Roller stopper	Stainless steel	
7	Pinion	Carbon steel	Nitriding
8	Cap A	Aluminum alloy	Clear anodized
9	Cap B	Aluminum alloy	Clear anodized
10	Cap C	Aluminum alloy	Clear anodized

### Component Parts

No.	Description	Material	Note
11	Head bumper	Urethane rubber	
12	Clip	Stainless steel wire	
13	Rack	Stainless steel	Nitriding
14	Magnet	—	Nickel plating
15	Steel ball	High carbon chromium bearing steel	
16	Wear ring	Synthetic resin	
17	Roller	High carbon chromium bearing steel	
18	Needle roller	High carbon chromium bearing steel	
19	Parallel pin	Stainless steel	
20	Piston seal	NBR	
21	Gasket	NBR	

### Replacement Parts

Description	Kit no.			Contents
	MHF2-8D	MHF2-8D1	MHF2-8D2	
Seal kit	MHF8-PS	MHF8-PS	MHF8-PS-2	12, 20, 21
Finger assembly	MHF-A0802	MHF-A0802-1	MHF-A0802-2	3, 4, 5, 6, 15, 17, 19, Mounting screw

Replacement part/Grease pack part no.:  
 Guide unit: GR-S-010 (10 g)  
 Cylinder unit: GR-L-005 (5 g)

### Bolts for Body Through-hole Mounting

Part no.	Number of pieces	
	MHF2-8D	MHF2-8D1
MHF-B08	MHF2-8D	2 pieces/unit
	MHF2-8D1	2 pieces/unit
	MHF2-8D2	4 pieces/unit

\* The bolts for body through-hole mounting are attached to the product. They are also provided at an order of 1 piece or more with the above part numbers.

## Construction

### MHF2-12D□ to 20D□

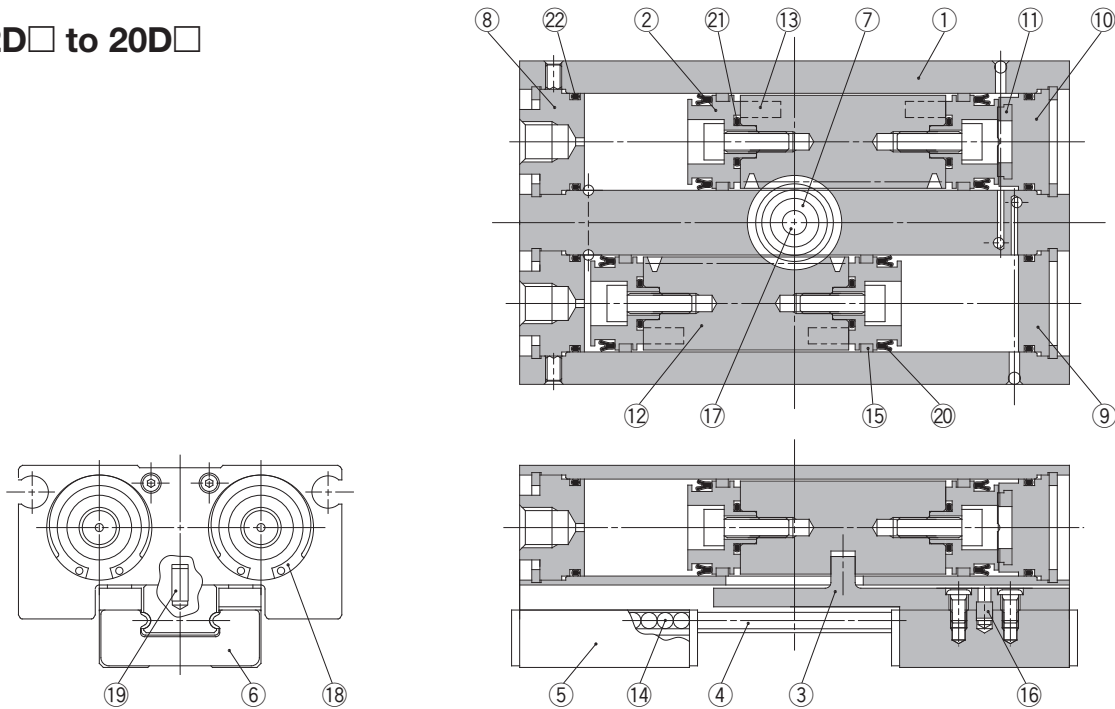

### Component Parts

No.	Description	Material	Note
1	Body	Aluminum alloy	Hard anodized
2	Piston	Aluminum alloy	Clear anodized
3	Joint	Stainless steel	Heat treatment
4	Guide rail	Stainless steel	Heat treatment
5	Finger	Stainless steel	Heat treatment
6	Roller stopper	Stainless steel	
7	Pinion	Carbon steel	Nitriding
8	Cap A	Aluminum alloy	Clear anodized
9	Cap B	Aluminum alloy	Clear anodized
10	Cap C	Aluminum alloy	Clear anodized
11	Head bumper	Urethane rubber	
12	Rack	Stainless steel	Nitriding

No.	Description	Material	Note
13	Magnet	—	Nickel plating
14	Steel ball	High carbon chromium bearing steel	
15	Wear ring	Synthetic resin	
16	ø12: Roller ø16 to ø20: Parallel pin	High carbon chromium bearing steel Stainless steel	
17	Needle roller	High carbon chromium bearing steel	
18	ø12: R shape retaining ring ø16 to ø20: Type C retaining ring	Carbon steel	Phosphate coating
19	Parallel pin	Stainless steel	
20	Piston seal	NBR	
21	Gasket	NBR	
22	Gasket	NBR	

### Replacement Parts

Description	Kit no.			Contents
	MHF2-12D	MHF2-12D1	MHF2-12D2	
Seal kit	MHF12-PS	MHF12-PS	MHF12-PS	20, 21, 22
Finger assembly	MHF-A1202	MHF-A1202-1	MHF-A1202-2	3, 4, 5, 6, 14, 16, 19, Mounting screw
Description	Kit no.			Contents
	MHF2-16D	MHF2-16D1	MHF2-16D2	
Seal kit	MHF16-PS	MHF16-PS	MHF16-PS	20, 21, 22
Finger assembly	MHF-A1602	MHF-A1602-1	MHF-A1602-2	3, 4, 5, 6, 14, 16, 19, Mounting screw
Description	Kit no.			Contents
	MHF2-20D	MHF2-20D1	MHF2-20D2	
Seal kit	MHF20-PS	MHF20-PS	MHF20-PS	20, 21, 22
Finger assembly	MHF-A2002	MHF-A2002-1	MHF-A2002-2	3, 4, 5, 6, 14, 16, 19, Mounting screw

### Bolts for Body Through-hole Mounting

Part no.	Number of pieces	
	MHF2-12D	MHF2-12D1
MHF-B12	MHF2-12D	2 pieces/unit
	MHF2-12D1	2 pieces/unit
	MHF2-12D2	4 pieces/unit

\* The bolts for body through-hole mounting are attached to the product. They are also provided at an order of 1 piece or more with the above part numbers.

\* When mounting MHF2-16D□ or MHF2-20D□ with the body through-holes, use hexagon socket head cap screws available on the market.

### Grease Pack Part Nos.

MHF2-□□D, D1 (ø12, ø16, ø20)	GR-S-010 (10 g) (Guide unit)
MHF2-□□D2 (ø12)	GR-L-005 (5 g) (Cylinder unit)
MHF2-□□D2 (ø16, ø20)	GR-S-010 (10 g) (Guide unit)
	GR-L-010 (10 g) (Cylinder unit)

# MHF2 Series

## Dimensions: 8D

### MHF2-8D

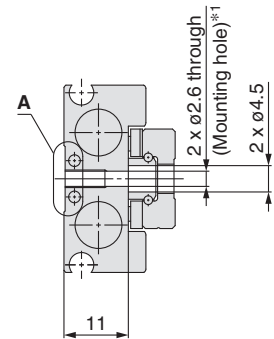
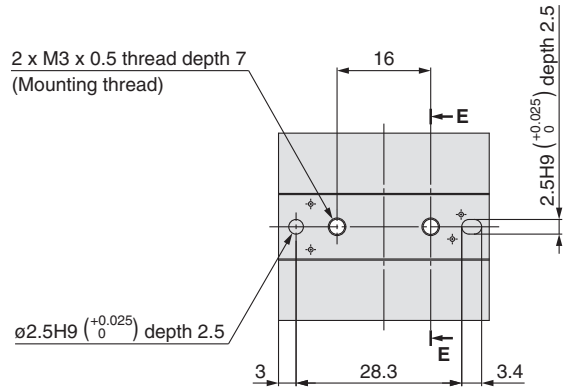

E-E

\*1 Use the attached hexagon socket head cap screws for mounting holes.

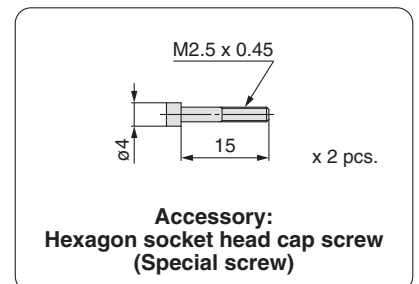
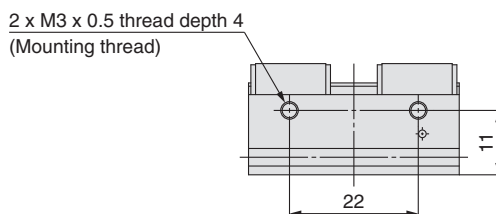
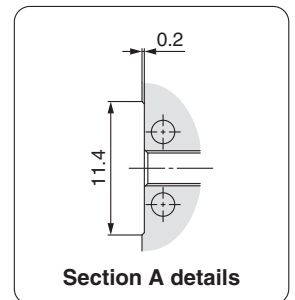
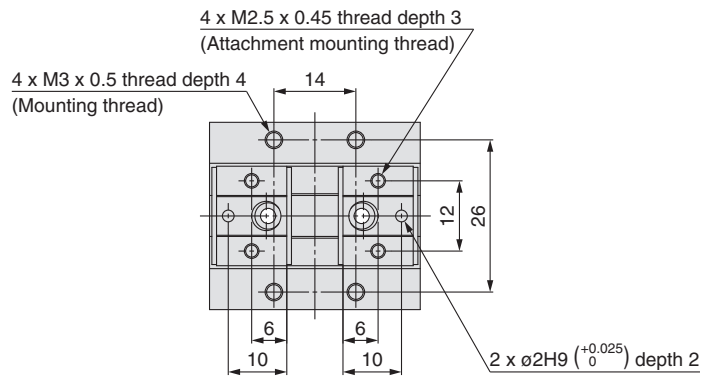
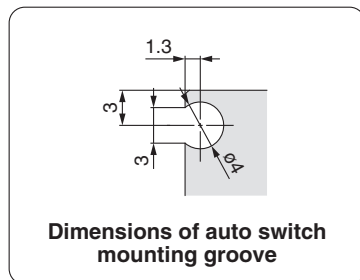
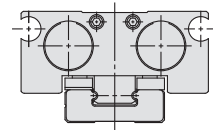
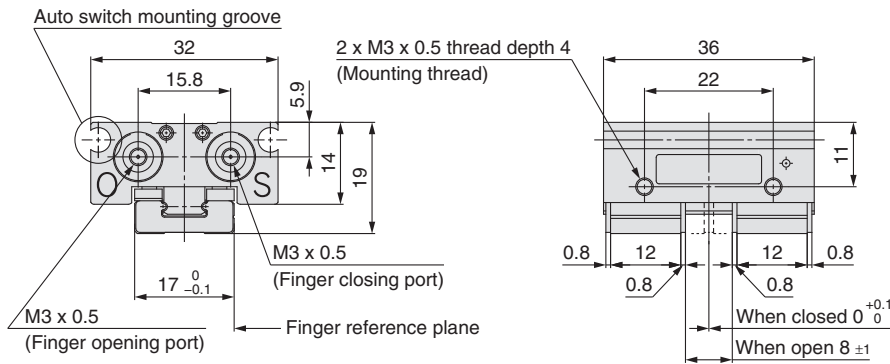

**Dimensions: 8D1**

**MHF2-8D1**

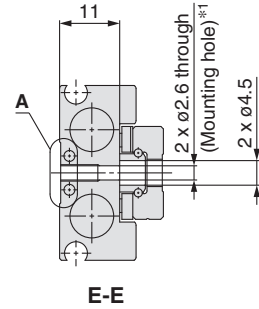
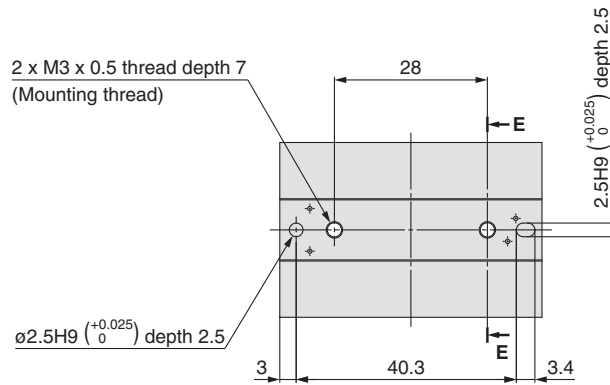

\*1 Use the attached hexagon socket head cap screws for mounting holes.

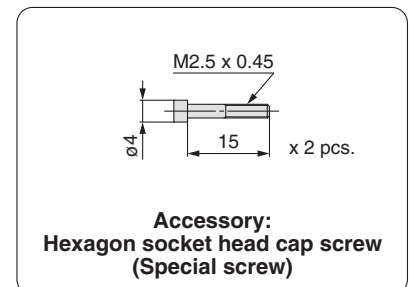
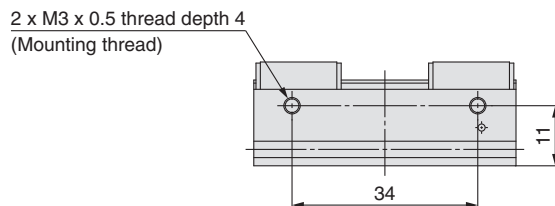
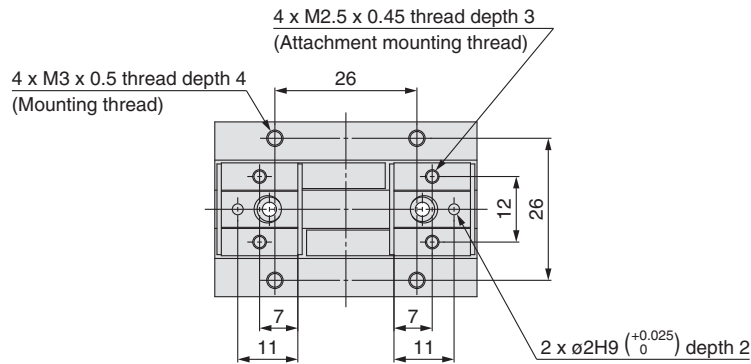
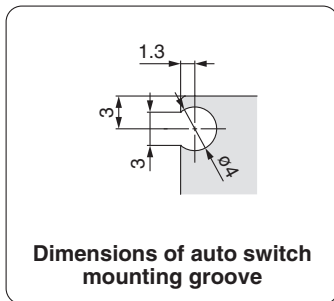
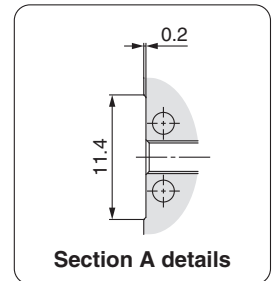
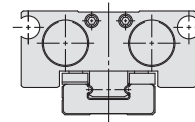
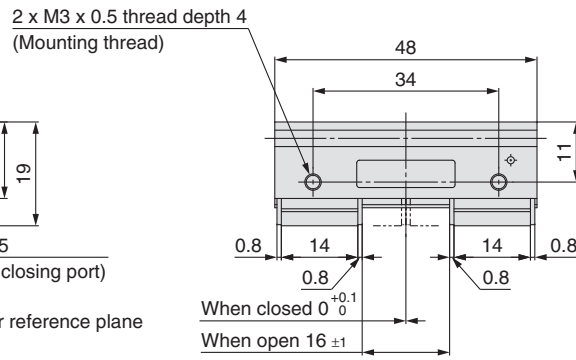
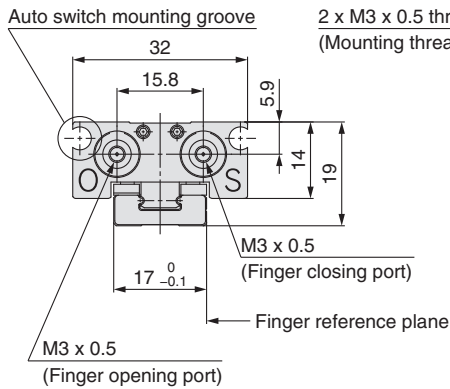

# MHF2 Series

## Dimensions: 8D2

### MHF2-8D2

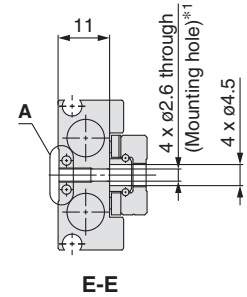
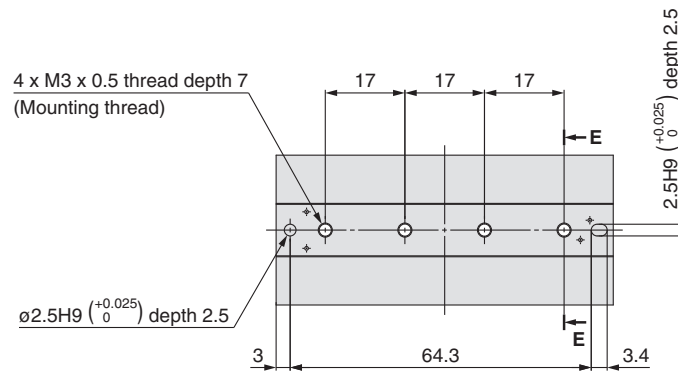

\*1 Use the attached hexagon socket head cap screws for mounting holes.

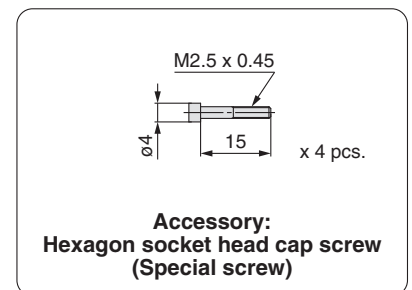
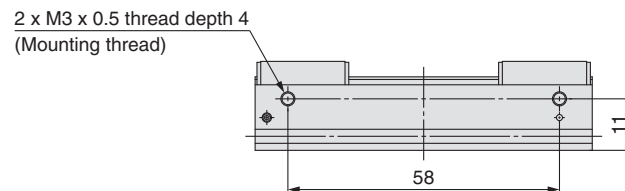
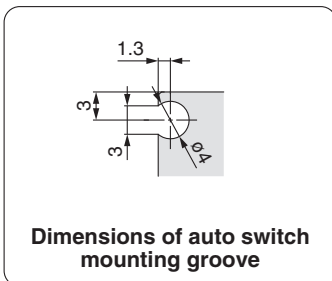
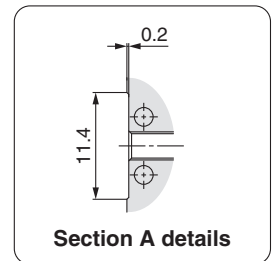
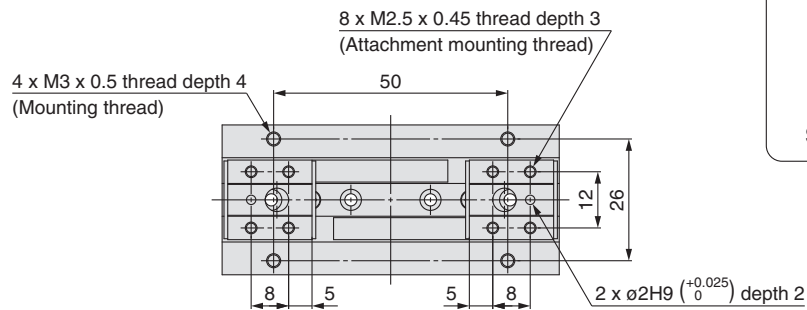
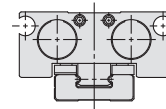
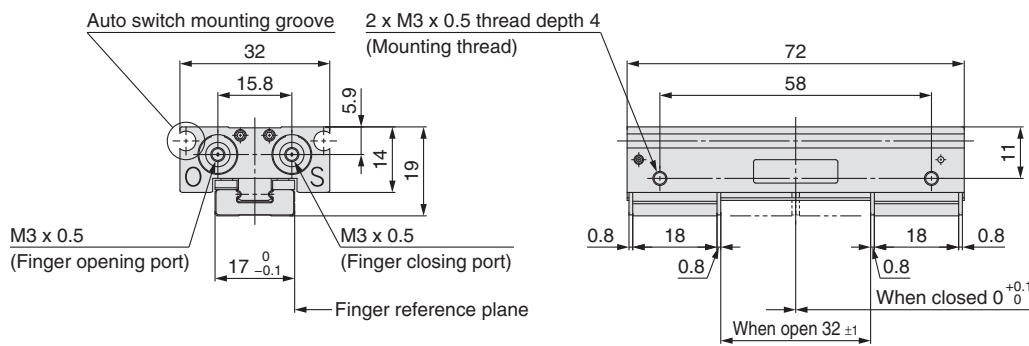

## Dimensions: **12D**

### MHF2-12D

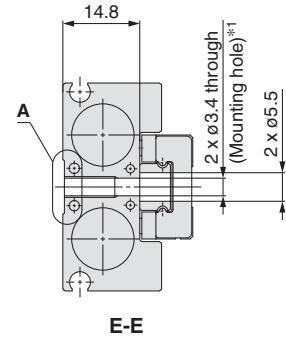
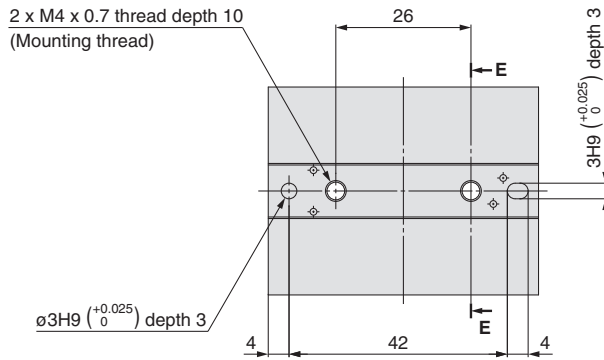

\*1 Use the attached hexagon socket head cap screws for mounting holes.

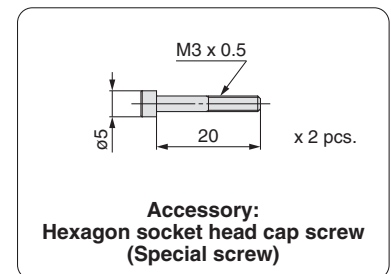
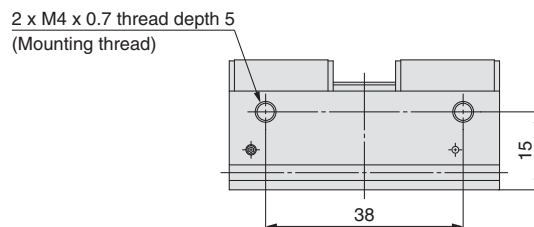
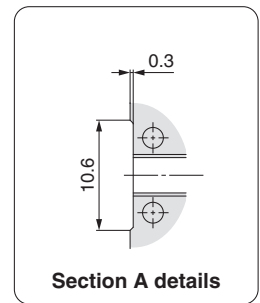
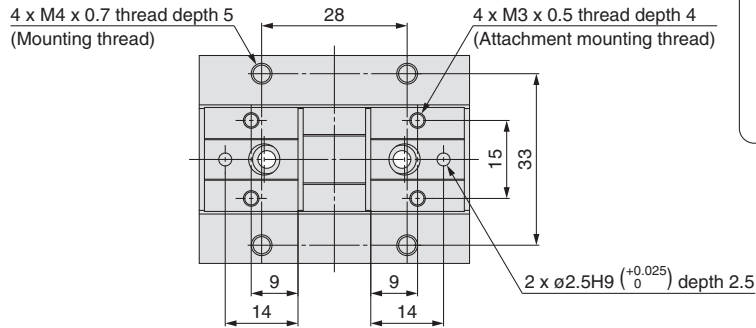
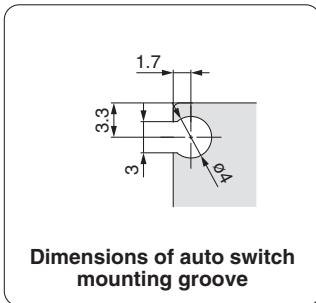
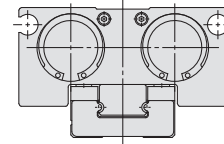
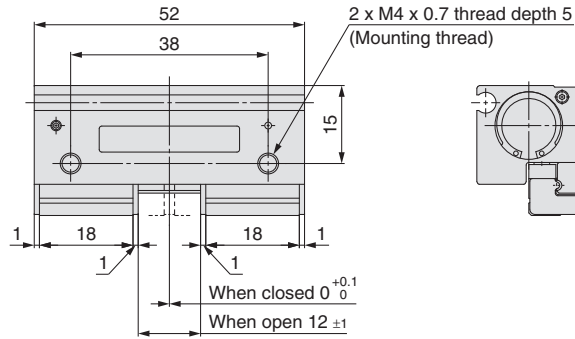
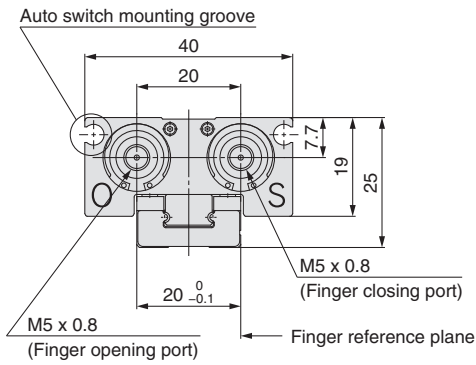

# MHF2 Series

## Dimensions: 12D1

### MHF2-12D1

2 x M4 x 0.7 thread depth 10  
(Mounting thread)

$\phi 3H9 \begin{smallmatrix} +0.025 \\ 0 \end{smallmatrix}$  depth 3

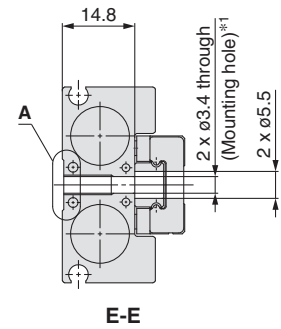
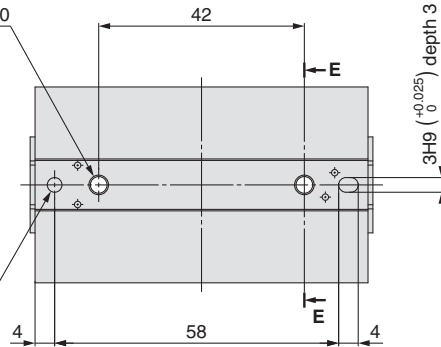

\*1 Use the attached hexagon socket head cap screws for mounting holes.

Auto switch mounting groove

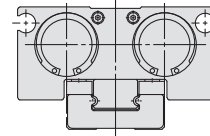
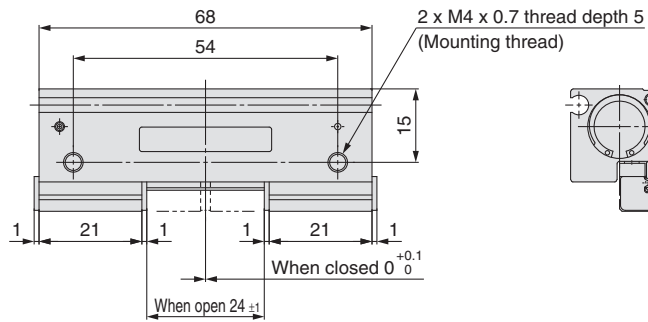
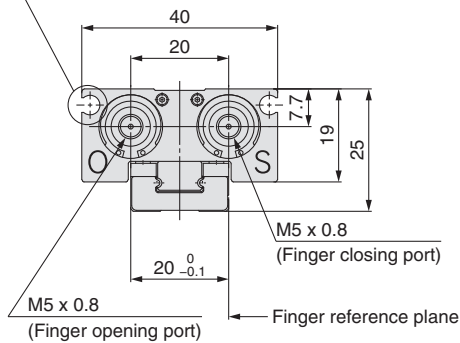

4 x M4 x 0.7 thread depth 5  
(Mounting thread)

8 x M3 x 0.5 thread depth 4  
(Attachment mounting thread)

2 x  $\phi 2.5H9 \begin{smallmatrix} +0.025 \\ 0 \end{smallmatrix}$  depth 2.5

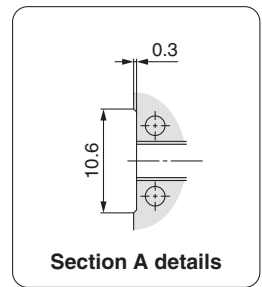
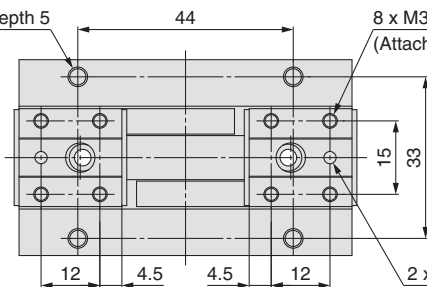

Section A details

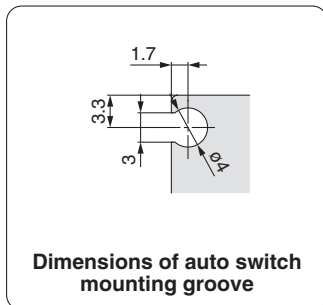

2 x M4 x 0.7 thread depth 5  
(Mounting thread)

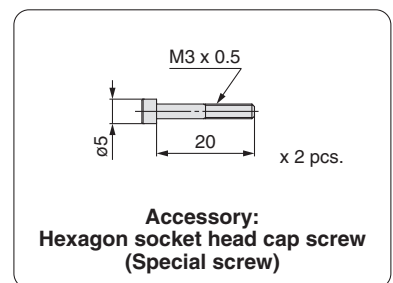
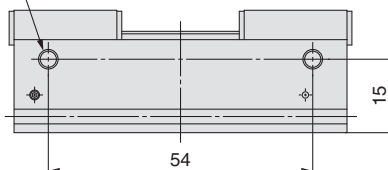

Accessory:  
Hexagon socket head cap screw  
(Special screw)



## Dimensions: **12D2**

### MHF2-12D2

4 x M4 x 0.7 thread depth 10  
(Mounting thread)

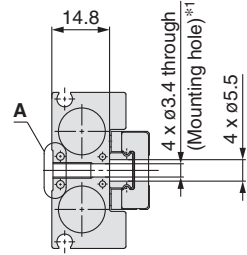
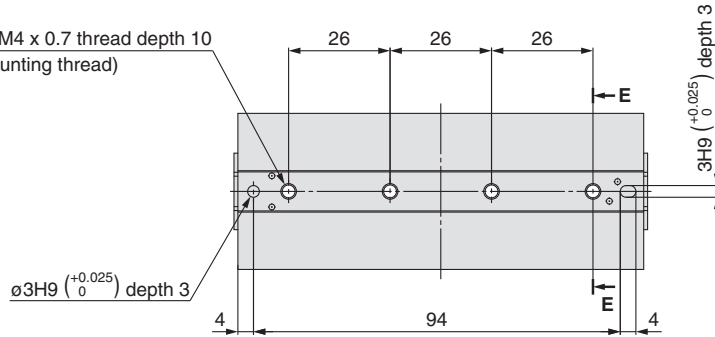

**E-E**

\*1 Use the attached hexagon socket head cap screws for mounting holes.

Auto switch mounting groove

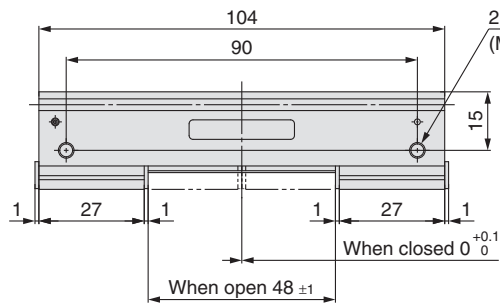
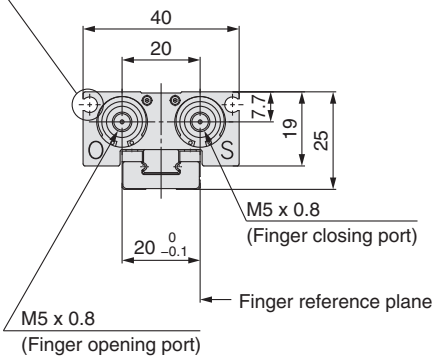

2 x M4 x 0.7 thread depth 5  
(Mounting thread)

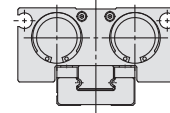

4 x M4 x 0.7 thread depth 5  
(Mounting thread)

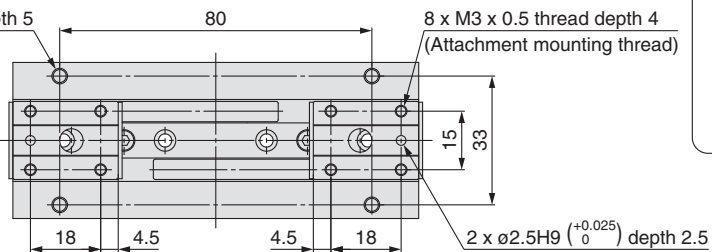

8 x M3 x 0.5 thread depth 4  
(Attachment mounting thread)

2 x 2.5H9 (+0.025/0) depth 2.5

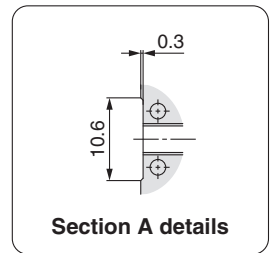

**Section A details**

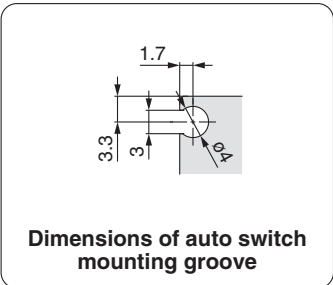

**Dimensions of auto switch mounting groove**

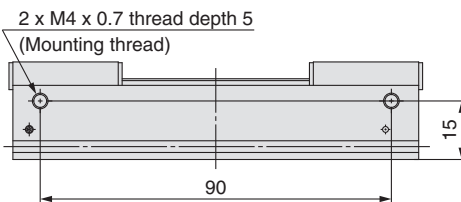

2 x M4 x 0.7 thread depth 5  
(Mounting thread)

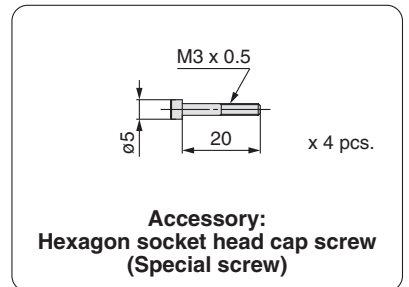

**Accessory:**  
Hexagon socket head cap screw  
(Special screw)

# MHF2 Series

## Dimensions: 16D

### MHF2-16D

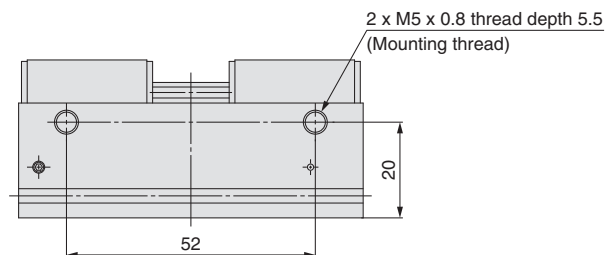
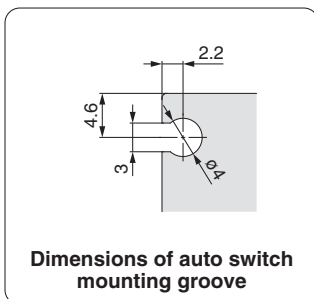
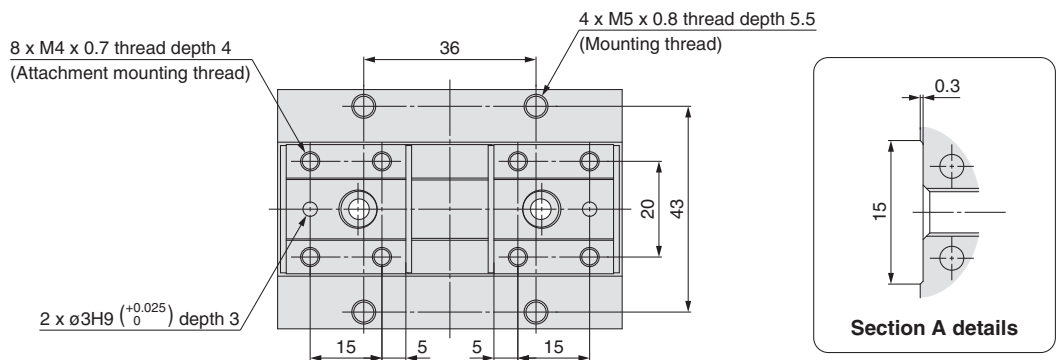
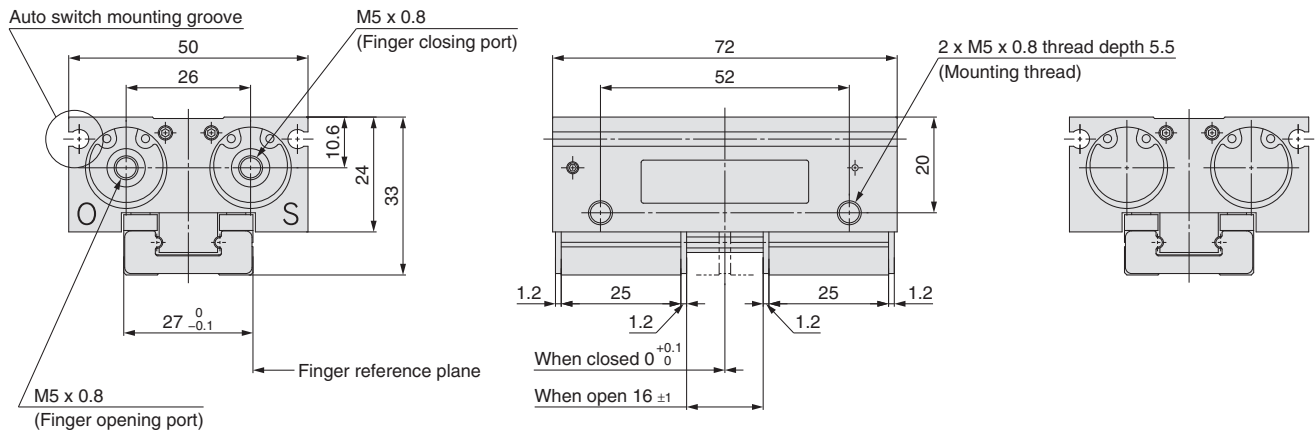
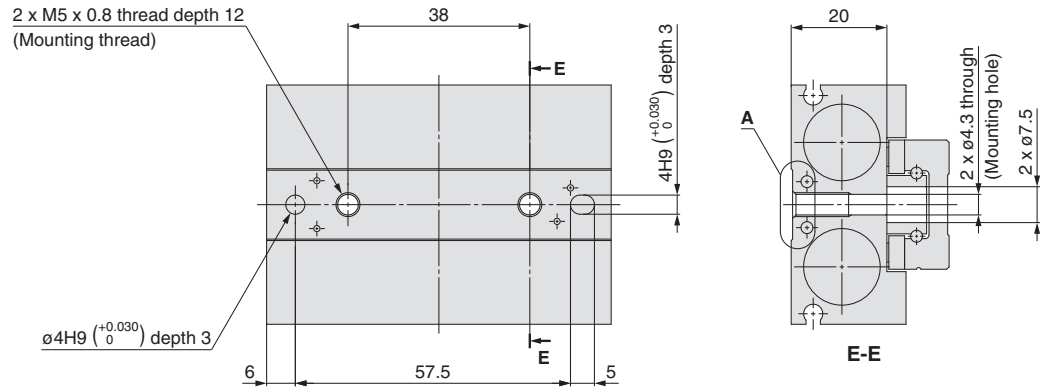

**Dimensions: 16D1**

**MHF2-16D1**

2 x M5 x 0.8 thread depth 12  
(Mounting thread)

$\phi 4H9 \begin{smallmatrix} +0.030 \\ 0 \end{smallmatrix}$  depth 3

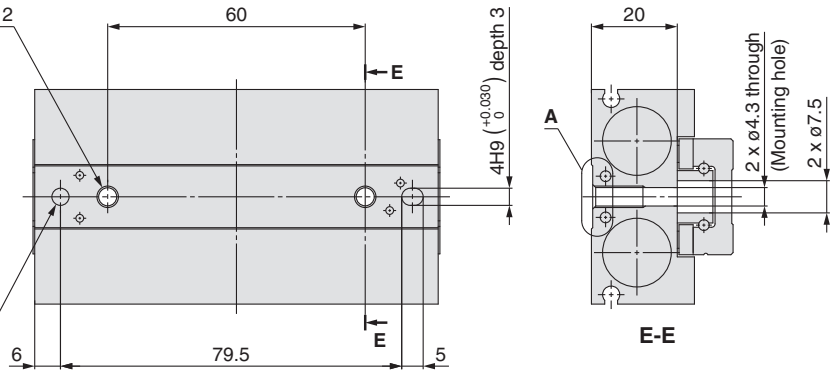

Auto switch mounting groove

M5 x 0.8

(Finger closing port)

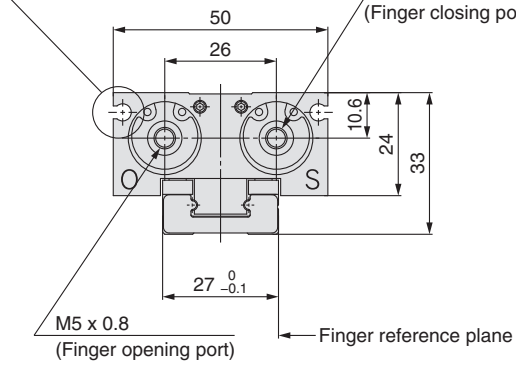

2 x M5 x 0.8 thread depth 5.5  
(Mounting thread)

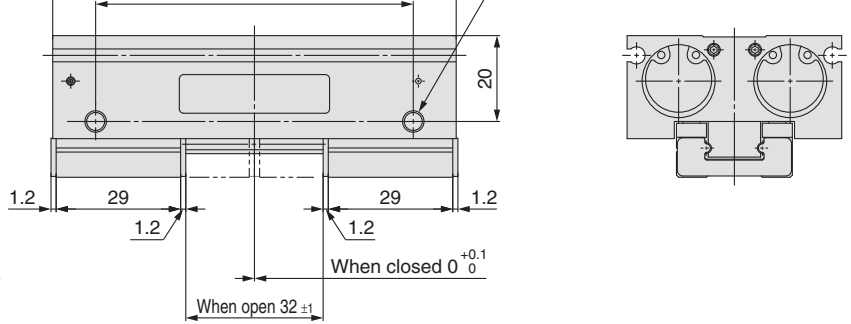

8 x M4 x 0.7 thread depth 4  
(Attachment mounting thread)

4 x M5 x 0.8 thread depth 5.5  
(Mounting thread)

2 x  $\phi 3H9 \begin{smallmatrix} +0.025 \\ 0 \end{smallmatrix}$  depth 3

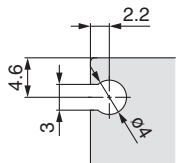
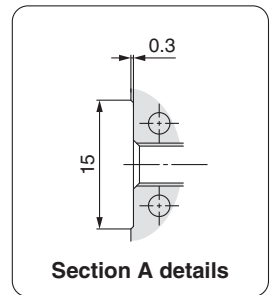
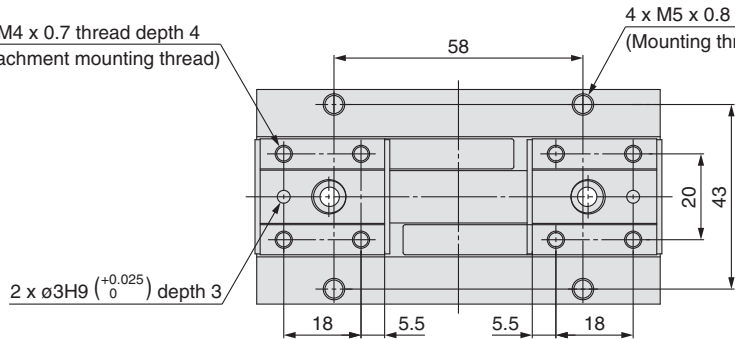

**Dimensions of auto switch mounting groove**

2 x M5 x 0.8 thread depth 5.5  
(Mounting thread)

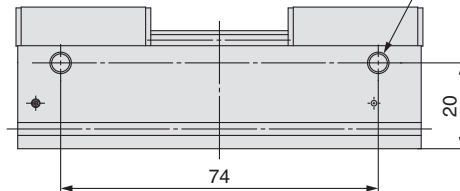

# MHF2 Series

## Dimensions: 16D2

### MHF2-16D2

4 x M5 x 0.8 thread depth 12  
(Mounting thread)

$\phi 4H9 \left( \begin{smallmatrix} +0.030 \\ 0 \end{smallmatrix} \right)$  depth 3

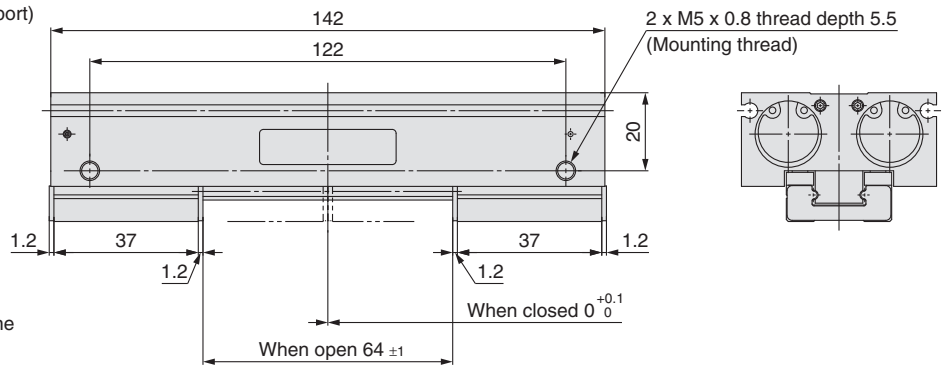
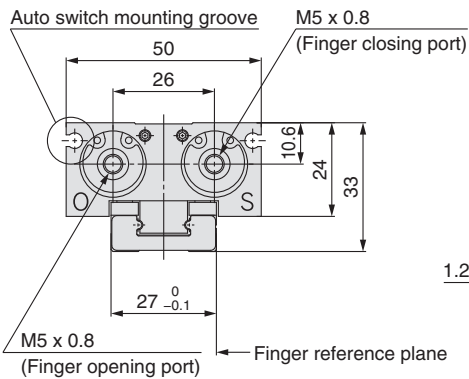
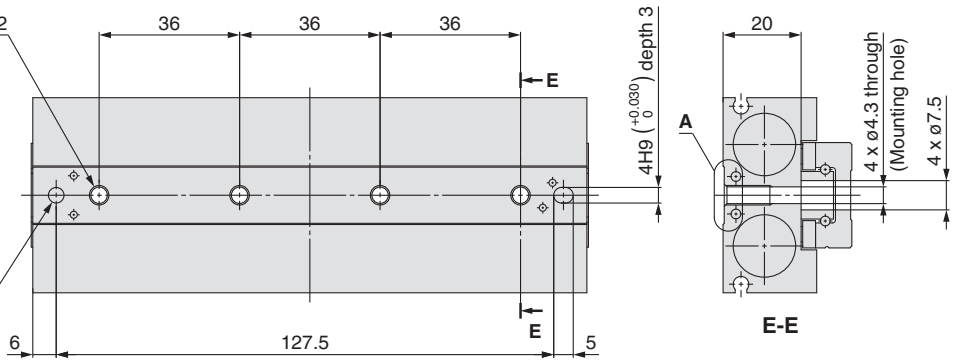

8 x M4 x 0.7 thread depth 4  
(Attachment mounting thread)

2 x  $\phi 3H9 \left( \begin{smallmatrix} +0.025 \\ 0 \end{smallmatrix} \right)$  depth 3

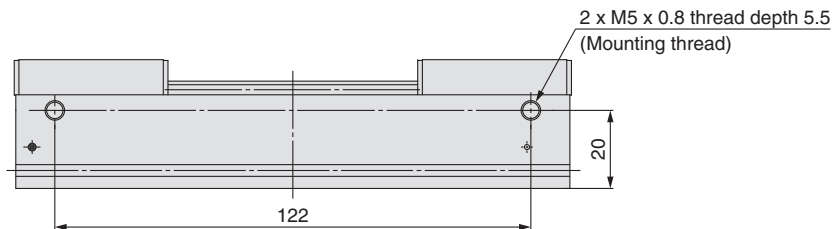
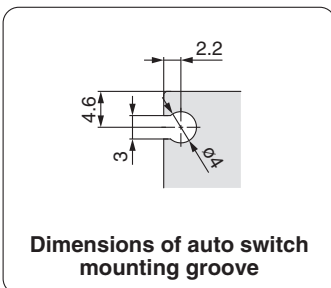
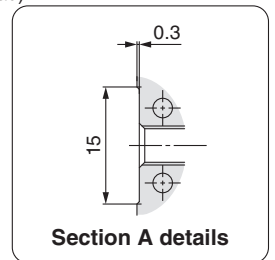
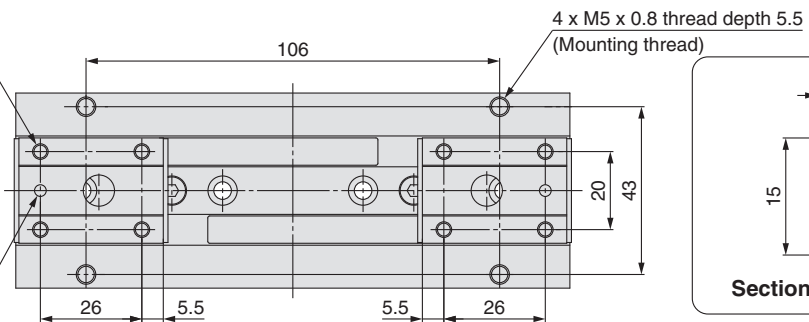

**Dimensions: 20D**

**MHF2-20D**

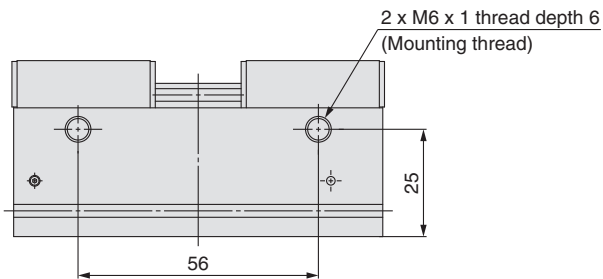
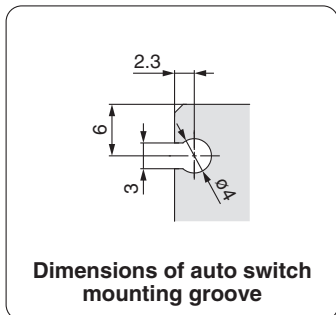
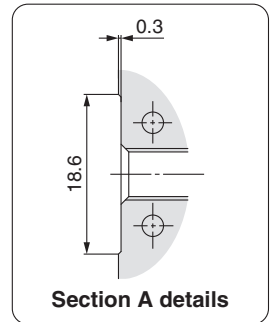
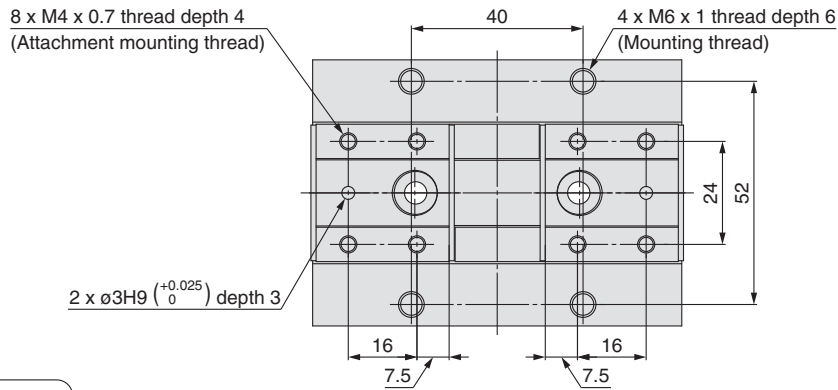
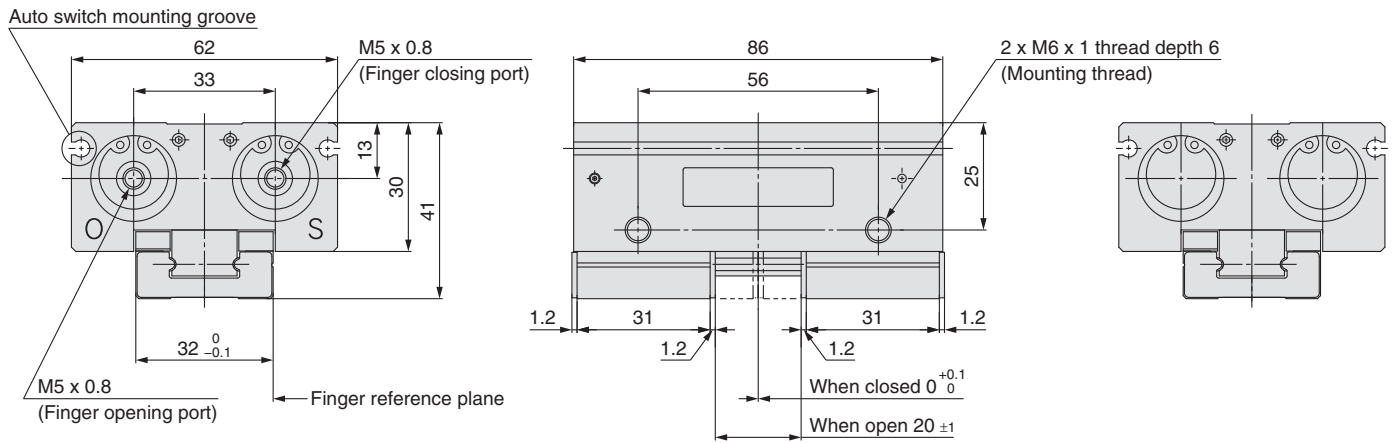
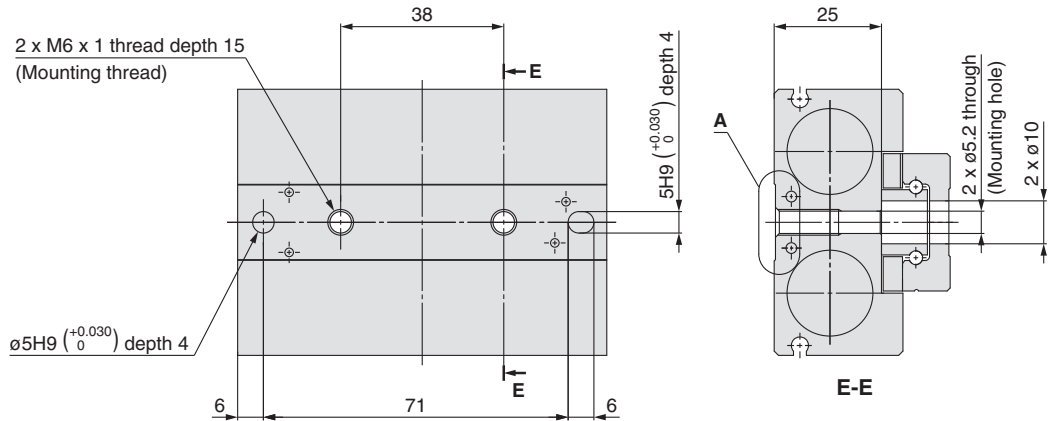

# MHF2 Series

## Dimensions: 20D1

### MHF2-20D1

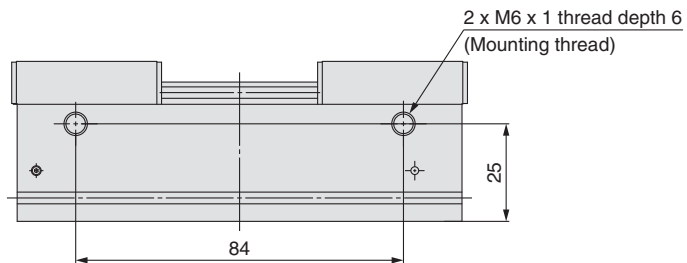
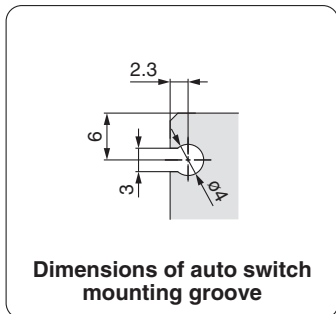
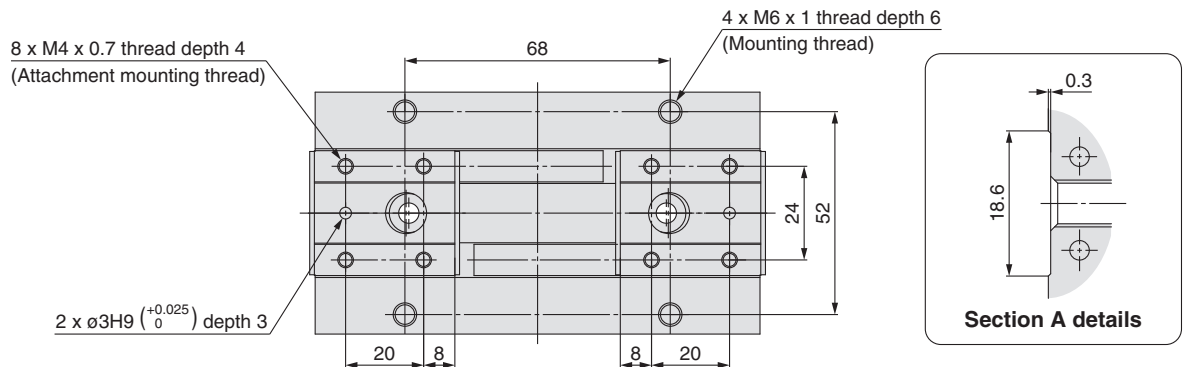
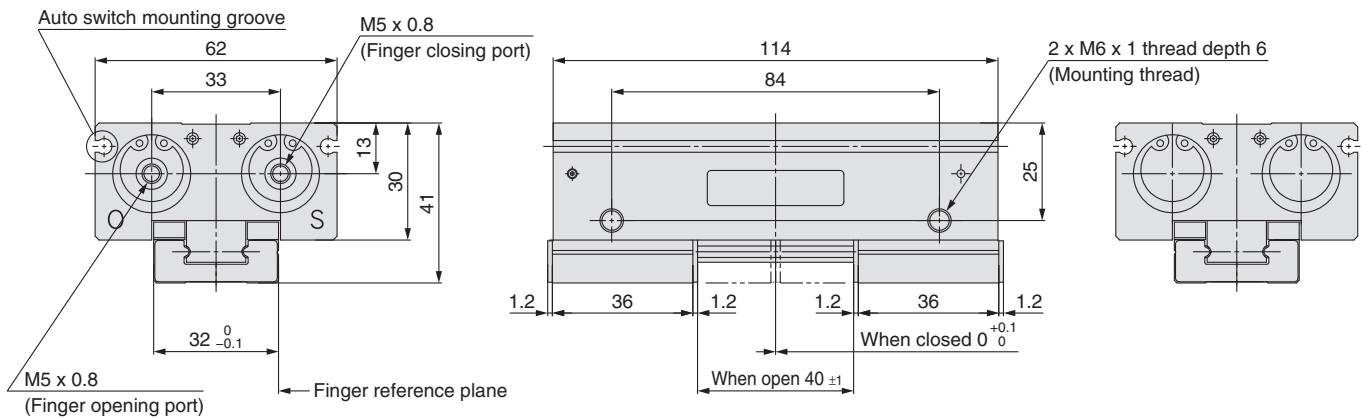
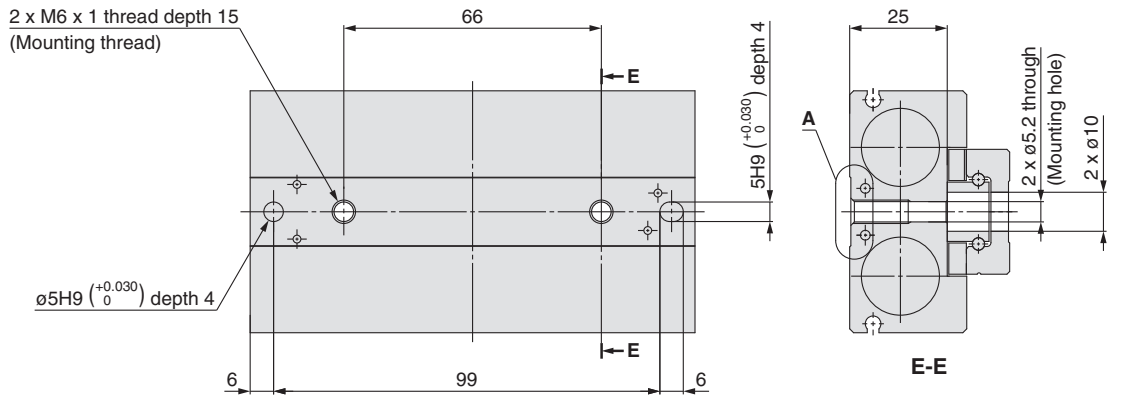

**Dimensions: 20D2**

**MHF2-20D2**

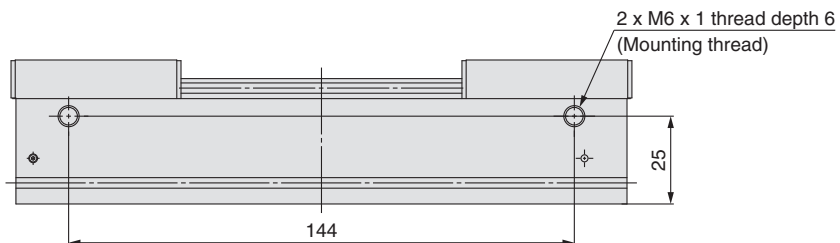
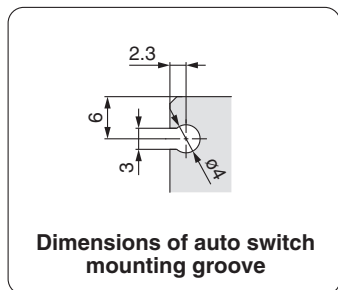
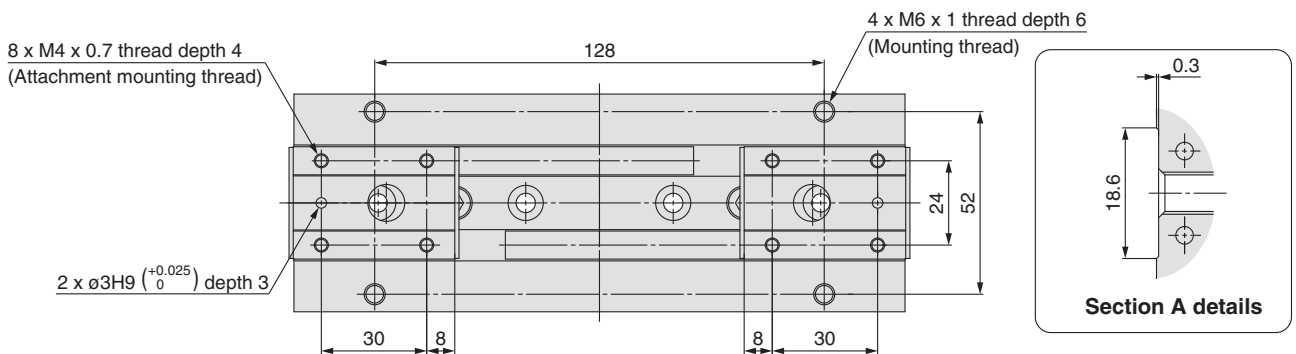
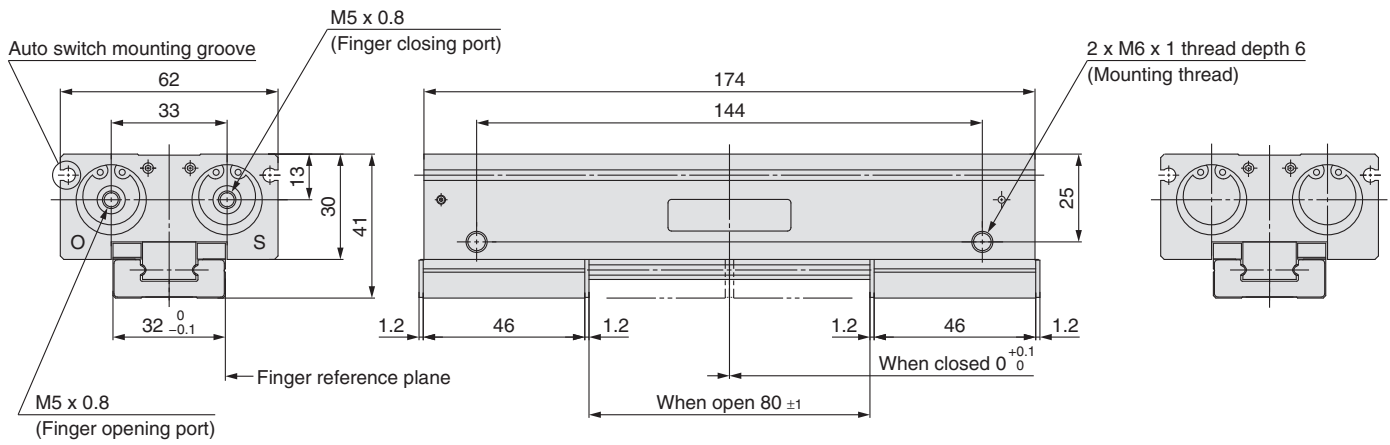
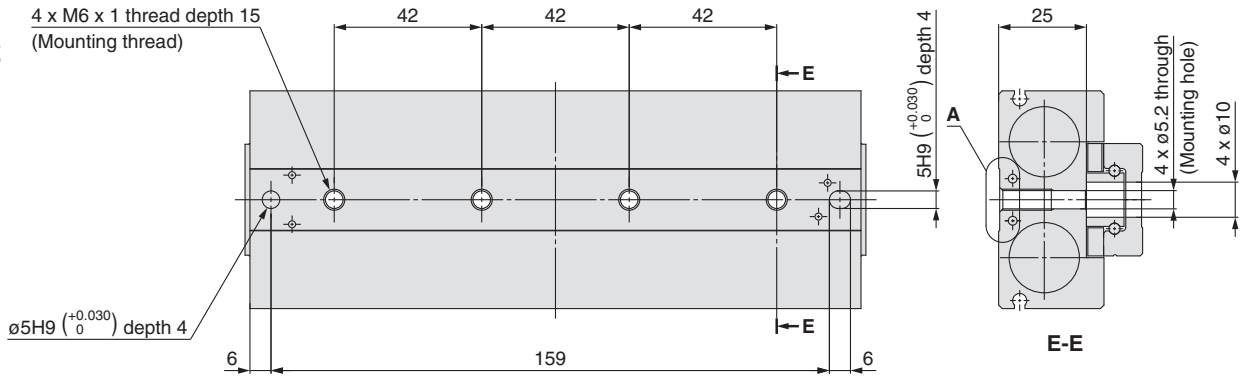

## MHF2 Series

# Body Option: Side Piping Type

MHF2-8DR  
MHF2-8D1R

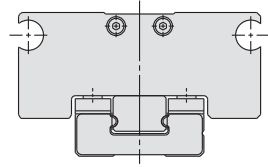

Port side of axial piping type

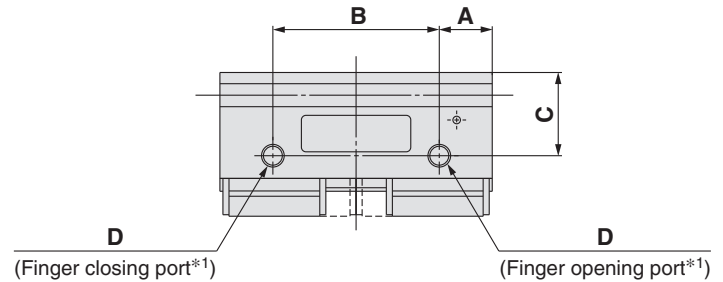

### Body Option Dimensions

[mm]

Model	A	B	C	D
MHF2-8DR	5.5	25	11	M3 x 0.5
MHF2-8D1R		37		

MHF2-8D2R  
MHF2-12D□R  
MHF2-16D□R  
MHF2-20D□R

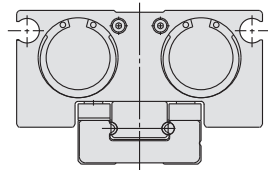

Port side of axial piping type

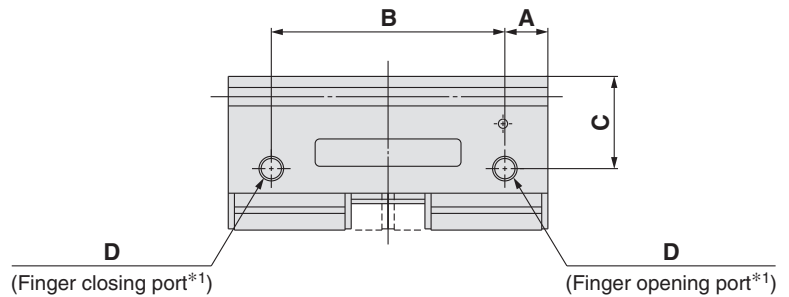

### Body Option Dimensions

[mm]

Model	A	B	C	D
MHF2-8D2R	5.5	61	11	M3 x 0.5
MHF2-12DR	7	38	14.8	M5 x 0.8
MHF2-12D1R		54		
MHF2-12D2R		90		
MHF2-16DR	9	54	19	M5 x 0.8
MHF2-16D1R		76		
MHF2-16D2R		124		
MHF2-20DR	10	66	23	M5 x 0.8
MHF2-20D1R		94		
MHF2-20D2R		154		

\*1 There is no port on the other side of the product.

\* There are no mounting threads for the port side surface.

\* Dimensions other than those shown above are the same as those of the axial piping type.

For details, refer to the dimensions on pages 11 to 22.



# MHF2 Series

# Auto Switch Installation Examples and Mounting Positions

Various auto switch applications are possible through different combinations of auto switch quantities and detecting positions.

## 1) Detection when Gripping Exterior of a Workpiece

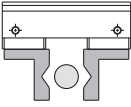
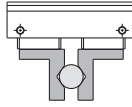
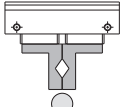
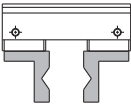
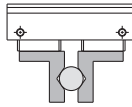
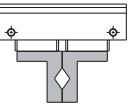
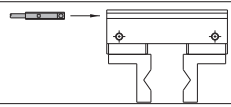
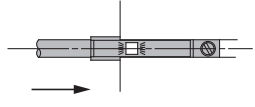
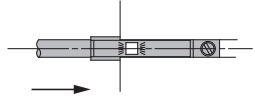
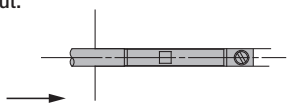
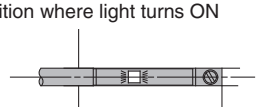
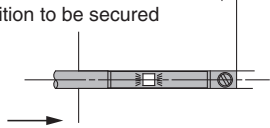
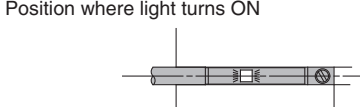
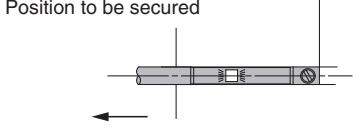
Detection example		① Confirmation of fingers in reset position	② Confirmation of a workpiece held	③ Confirmation of a workpiece released
Position to be detected		Position of fingers fully open 	Position when gripping a workpiece 	Position of fingers fully closed 
Operation of auto switches		When fingers return: Auto switch to turn ON (Light ON)	When gripping a workpiece: Auto switch to turn ON (Light ON)	When a workpiece is not held (Abnormal operation): Auto switch to turn ON (Light ON)
Detection combinations	One auto switch * One position, any of ①, ② and ③ can be detected.	●	●	●
	Two auto switches * Two positions of ①, ② and ③ can be detected.	Pattern A	●	-
		Pattern B	-	●
Pattern C	●	-	●	
How to determine auto switch installation position		Step 1) Fully open the fingers. 	Step 1) Position fingers for gripping a workpiece. 	Step 1) Fully close the fingers. 
At no pressure or low pressure, connect the auto switch to a power supply, and follow the directions.		Step 2) Insert the auto switch into the auto switch mounting groove in the direction as shown in the illustration to the right. 		
		Step 3) Slide the auto switch in the direction of the arrow until the indicator light illuminates and fasten it at a position 0.3 to 0.5 mm in the direction of the arrow beyond the position where the indicator light illuminates. 	Step 3) Slide the auto switch in the direction of the arrow until the indicator light illuminates. 	Step 4) Slide the auto switch further in the direction of the arrow until the indicator light goes out. 
		Position where light turns ON  0.3 to 0.5 mm Position to be secured 		Position where light turns ON  0.3 to 0.5 mm Position to be secured 

- \* It is recommended that gripping of a workpiece be performed close to the center of the finger stroke.
- \* When holding a workpiece close at the end of opening/closing stroke of fingers, detecting performance of the combinations listed in the table above may be limited, depending on the hysteresis of an auto switch, etc.

## MHF2 Series

# Auto Switch Installation Examples and Mounting Positions

Various auto switch applications are possible through different combinations of auto switch quantities and detecting positions.

## 2) Internal Gripping

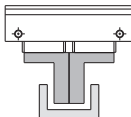
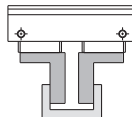
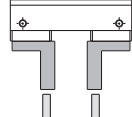
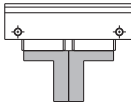
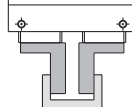
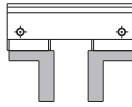
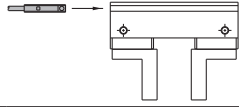
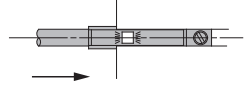
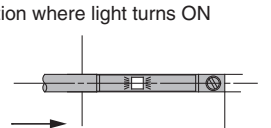
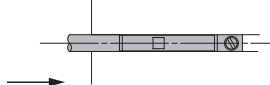
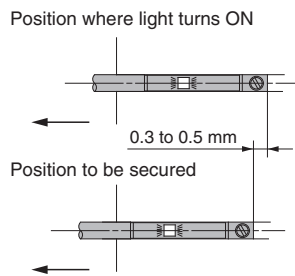
Detection example		① Confirmation of fingers in reset position	② Confirmation of a workpiece held	③ Confirmation of a workpiece released	
Position to be detected		Position of fingers fully closed 	Position when gripping a workpiece 	Position of fingers fully open 	
Operation of auto switches		When fingers return: Auto switch to turn ON (Light ON)	When gripping a workpiece: Auto switch to turn ON (Light ON)	When a workpiece is not held (Abnormal operation): Auto switch to turn ON (Light ON)	
Detection combinations	One auto switch * One position, any of ①, ② and ③ can be detected.	●	●	●	
	Two auto switches * Two positions of ①, ② and ③ can be detected.	Pattern A	●	-	
		Pattern B	-	●	●
Pattern C	●	-	●		
How to determine auto switch installation position		Step 1) Fully close the fingers. 	Step 1) Position fingers for gripping a workpiece. 	Step 1) Fully open the fingers. 	
At no pressure or low pressure, connect the auto switch to a power supply, and follow the directions.		Step 2) Insert the auto switch into the auto switch mounting groove in the direction as shown in the illustration to the right. 			
		Step 3) Slide the auto switch in the direction of the arrow until the indicator light illuminates. 	Step 3) Slide the auto switch in the direction of the arrow until the indicator light illuminates and fasten it at a position 0.3 to 0.5 mm in the direction of the arrow beyond the position where the indicator light illuminates. 		
		Step 4) Slide the auto switch further in the direction of the arrow until the indicator light goes out. 			
		Step 5) Slide the auto switch in the opposite direction and fasten it at a position 0.3 to 0.5 mm beyond the position where the indicator light illuminates. 			

- \* It is recommended that gripping of a workpiece be performed close to the center of the finger stroke.
- \* When holding a workpiece close at the end of opening/closing stroke of fingers, detecting performance of the combinations listed in the table above may be limited, depending on the hysteresis of an auto switch, etc.

## Auto Switch Hysteresis

Auto switches have hysteresis similar to micro switches. Use the table below as a guide when adjusting auto switch positions, etc.

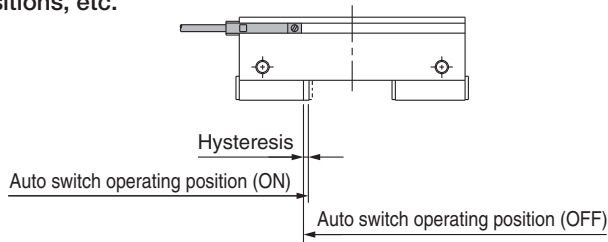

## Hysteresis

	D-M9□(V) D-M9□W(V) D-M9□A(V)
MHF2-8D□	0.2
MHF2-12D□	0.3
MHF2-16D□	0.2
MHF2-20D□	0.5

## Auto Switch Mounting

To set the auto switch, insert the auto switch into the auto switch mounting groove of the gripper from the direction as shown in the illustration below. After setting the position, tighten the attached auto switch mounting screw with a flat blade watchmaker's screwdriver.

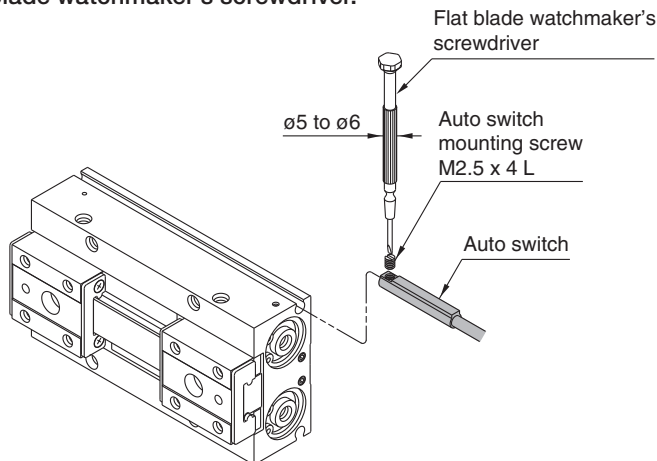

\* Use a watchmaker's screwdriver with a grip diameter of 5 to 6 mm to tighten the auto switch mounting screw. Also, tighten with a torque of about 0.05 to 0.15 N·m, or about 0.05 to 0.10 N·m for D-M9□A(V).

## ⚠ Caution

When using an auto switch on the mounting plate side, the switch will protrude from the end face as shown in the right figure. Please provide a run off space of 2 mm or more on the mounting plate.

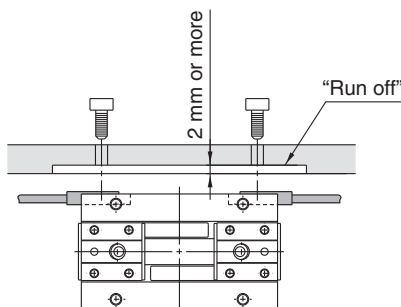

## Protrusion of Auto Switch from Edge of Body

- The amount of auto switch protrusion from the body end surface is shown in the table below.
- Use this as a standard when mounting, etc.

## Protrusion of Auto Switch

Model	Lead wire type Illustration Finger position Auto switch	In-line entry		Perpendicular entry	
		D-M9□ D-M9□W	D-M9□A	D-M9□V D-M9□WV	D-M9AV
MHF2-8D	Open	6.5	8.5	4.5	6.5
	Closed	6.5	8.5	4.5	6.5
MHF2-8D1	Open	6.5	8.5	4.5	6.5
	Closed	6.5	8.5	4.5	6.5
MHF2-8D2	Open	0.5	2.5	---	---
	Closed	0.5	2.5	---	---
MHF2-12D	Open	3	5	1	3
	Closed	3	5	1	3
MHF2-12D1	Open	1	3	---	---
	Closed	1	3	---	---
MHF2-12D2	Open	---	---	---	---
	Closed	---	---	---	---
MHF2-16D	Open	---	---	---	---
	Closed	---	---	---	---
MHF2-16D1	Open	---	---	---	---
	Closed	---	---	---	---
MHF2-16D2	Open	---	---	---	---
	Closed	---	---	---	---
MHF2-20D	Open	---	---	---	---
	Closed	---	---	---	---
MHF2-20D1	Open	---	---	---	---
	Closed	---	---	---	---
MHF2-20D2	Open	---	---	---	---
	Closed	---	---	---	---

\* There is no protrusion for sections of the table with no values entered.

# Prior to Use

## Auto Switch Connections and Examples

### Sink Input Specifications

#### 3-wire, NPN

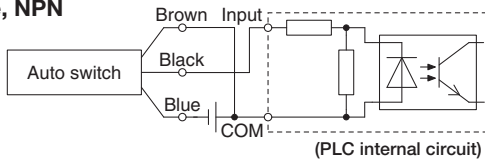

#### 2-wire

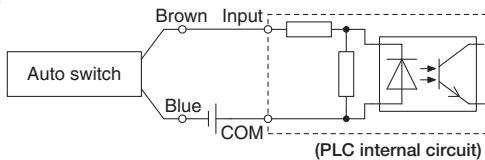

### Source Input Specifications

#### 3-wire, PNP

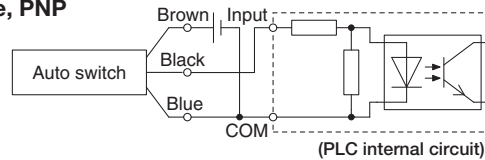

#### 2-wire

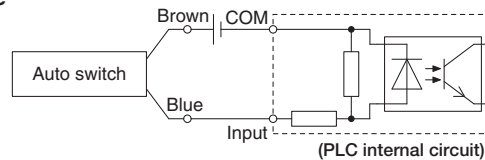

Connect according to the applicable PLC input specifications, as the connection method will vary depending on the PLC input specifications.

### Examples of AND (Series) and OR (Parallel) Connections

\* When using solid state auto switches, ensure the application is set up so the signals for the first 50 ms are invalid. Depending on the operating environment, the product may not operate properly.

#### 3-wire AND connection for NPN output (Using relays)

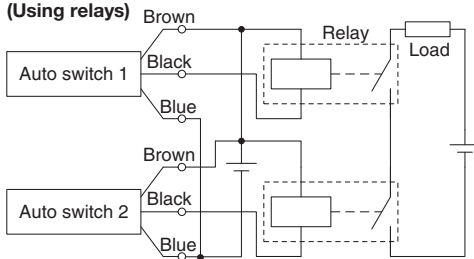

#### (Performed with auto switches only)

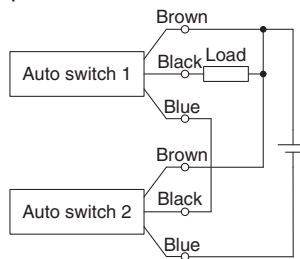

#### 3-wire OR connection for NPN output

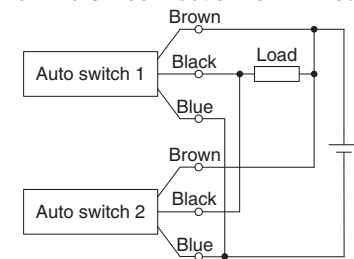

#### 3-wire AND connection for PNP output (Using relays)

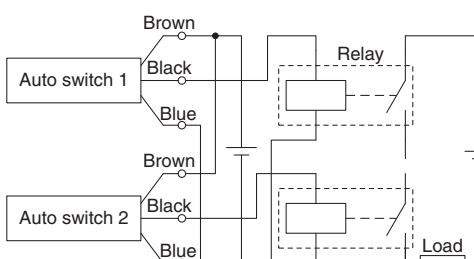

#### (Performed with auto switches only)

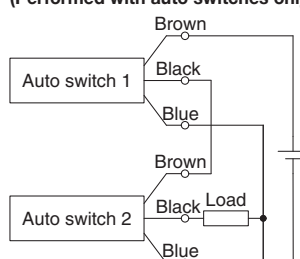

#### 3-wire OR connection for PNP output

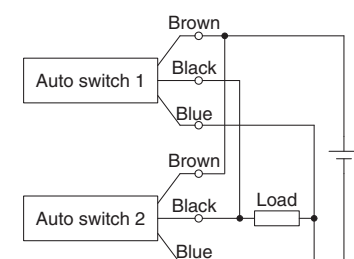

#### 2-wire AND connection

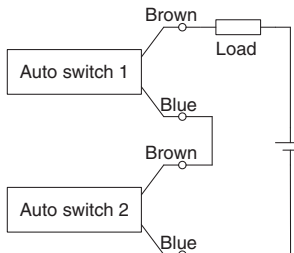

When two auto switches are connected in series, a load may malfunction because the load voltage will decline when in the ON state. The indicator lights will light up when both of the auto switches are in the ON state. Auto switches with a load voltage less than 20 V cannot be used. Please contact SMC if using AND connection for a heat-resistant solid state auto switch or a trimmer switch.

Example) Load voltage at ON  
 Power supply voltage: 24 VDC  
 Internal voltage drop: 4 V  
 Load voltage at ON = Power supply voltage – Internal voltage drop x 2 pcs.  
 = 24 V – 4 V x 2 pcs.  
 = 16 V

#### 2-wire OR connection

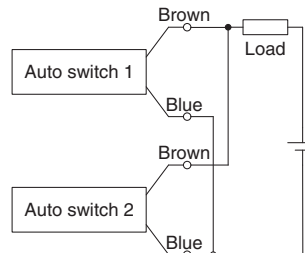

(Solid state)  
 When two auto switches are connected in parallel, malfunction may occur because the load voltage will increase when in the OFF state.

(Reed)  
 Because there is no current leakage, the load voltage will not increase when turned OFF. However, depending on the number of auto switches in the ON state, the indicator lights may sometimes grow dim or not light up, due to the dispersion and reduction of the current flowing to the auto switches.

Example) Load voltage at OFF  
 Leakage current: 1 mA  
 Load impedance: 3 kΩ  
 Load voltage at OFF = Leakage current x 2 pcs. x Load impedance  
 = 1 mA x 2 pcs. x 3 kΩ  
 = 6 V

# MHF2 Series

## Made to Order



① -X4	Heat Resistant (-10 to 100°C) .....	p. 29
② -X5	Fluororubber Seal .....	p. 29
③ -X50	Without Magnet .....	p. 29
④ -X53	Ethylene Propylene Rubber Seal (EPDM) .....	p. 30
⑤ -X63	Fluorine Grease .....	p. 30
⑥ -X79	Grease for Food Processing Machines: Fluorine Grease .....	p. 30
⑦ -X79A	Grease for Food Processing Machines: Aluminum Complex Soap Base Grease .....	p. 31
⑧ -X81□	Anti-corrosive Treatment of Finger .....	p. 31
	-X81A (Special black chromium treatment is made on only the finger.)	
	-X81B (Special black chromium treatment is made on the finger and guide.)	
⑨ -X83	With An Adjustable Opening/Closing Finger Positioning .....	p. 32
⑩ -X7050	Actuator Position Sensor Compatible Type .....	p. 35

# MHF2 Series

## 1 Heat Resistant (-10 to 100°C) Symbol -X4

Seal material and grease have been changed so that the product can be used at temperatures between -10 up to 100°C.

### How to Order

Standard model no. - X4  
Heat resistant ↓

### Specifications

Ambient temperature range	-10°C to 100°C (No freezing)
Seal material	Fluororubber
Grease	Heat-resistant grease (GR-F)
Specifications other than the above and dimensions	Same as those of the standard type

### Warning Precautions

Be aware that smoking cigarettes after your hands have come into contact with the grease used for this product can create a gas that is hazardous to humans.

- \* Magnet is built-in, but when using an auto switch, the acceptable temperature range becomes -10 to 60°C.
- \* For lubrication, specialized grease GR-F is recommended.

### Replacement Parts: Seal Kit

Seal kit part number
MHF□□-PS-X4 (MHF8-PS-2-X4 for the MHF2-8D2-X4)

- \* Enter the cylinder bore size into □□ of the seal kit part number. Refer to pages 9 and 10 for the replacement parts.
- \* The seal kit does not include a grease pack. Order it separately. Grease pack part number: GR-F-005 (5 g)

## 2 Fluororubber Seal Symbol -X5

### How to Order

Standard model no. - X5  
Fluororubber seal ↓

### Specifications

Seal material	Fluororubber
Specifications other than the above and dimensions	Same as those of the standard type

- \* Please contact SMC, since the type of chemical and the operating temperature may not allow the use of this product.
- \* Since the standard type magnet is built-in, please contact SMC for the product's adaptability to the operating environment.

## 3 Without Magnet Symbol -X50

### How to Order

Standard model no. - X50  
Without magnet ↓

### Specifications

Magnet	None
Specifications other than the above and dimensions	Same as those of the standard type

# Made to Order **MHF2 Series**

## 4 Ethylene Propylene Rubber Seal (EPDM)

Symbol  
**-X53**

Seal material has been changed to ethylene propylene (EPDM), and grease to fluorine grease.

### How to Order

Standard model no.  - X53  
Ethylene propylene rubber seal (EPDM)

\* For lubrication, specialized grease GR-F is recommended.  
Grease pack part number: GR-F-005 (5 g)

### Specifications

Seal material	Ethylene propylene rubber (EPDM)
Grease	Fluorine grease (GR-F)
Specifications other than the above and dimensions	Same as those of the standard type

### Warning Precautions

Be aware that smoking cigarettes after your hands have come into contact with the grease used for this product can create a gas that is hazardous to humans.

## 5 Fluorine Grease

Symbol  
**-X63**

### How to Order

Standard model no.  - X63  
Fluorine grease

\* For lubrication, specialized grease GR-F is recommended.  
Grease pack part number: GR-F-005 (5 g)

### Warning Precautions

Be aware that smoking cigarettes after your hands have come into contact with the grease used for this product can create a gas that is hazardous to humans.

### Specifications

Grease	Fluorine grease (GR-F)
Specifications other than the above and dimensions	Same as those of the standard type

## 6 Grease for Food Processing Machines: Fluorine Grease

Symbol  
**-X79**

Use grease for food processing machines (NSF-H1 certified/fluorine grease).

### How to Order

Standard model no.  - X79  
Grease for food processing machines:  
Fluorine grease

\* For lubrication, specialized grease GR-H is recommended.  
Grease pack part number: GR-H-010 (10 g)

### Warning Precautions

Be aware that smoking cigarettes after your hands have come into contact with the grease used for this product can create a gas that is hazardous to humans.

### Caution

**Do not use air grippers in a food-related environment.**

<Not installable>

Food zone ..... Food may directly contact with air grippers, and is treated as food products.

<Installable>

Splash zone ..... Food may directly contact with air grippers, but is not treated as food products.

Non-food zone .... Air grippers do not directly contact food.

### Specifications

Grease	Grease for food processing machines (NSF-H1 certified)/Fluorine grease
Specifications other than the above and dimensions	Same as those of the standard type

\* If the fluorine grease is not applicable to the working environment, use "-X79A."

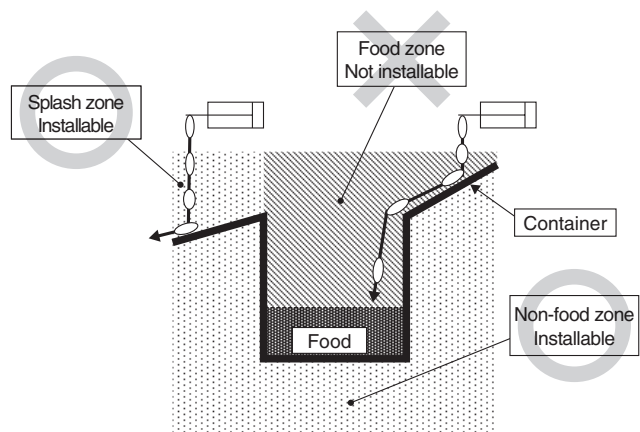

# MHF2 Series

## 7 Grease for Food Processing Machines: Aluminum Complex Soap Base Grease Symbol **-X79A**

Use grease for food processing machines (NSF-H1 certified).

### How to Order

Standard model no. **- X79A**  
 Grease for food processing machines:  
 Aluminum complex soap base grease

### ⚠ Caution

**Do not use air grippers in a food-related environment.**

<Not installable>

Food zone ..... Food may directly contact with air grippers, and is treated as food products.

<Installable>

Splash zone ..... Food may directly contact with air grippers, but is not treated as food products.

Non-food zone .... Air grippers do not directly contact food.

\* For lubrication, specialized grease GR-R is recommended.  
 Grease pack part number: GR-R-010 (10 g)

### Specifications

Grease	Grease for food processing machines (NSF-H1 certified)/Aluminum complex soap base grease
Specifications other than the above and dimensions	Same as those of the standard type

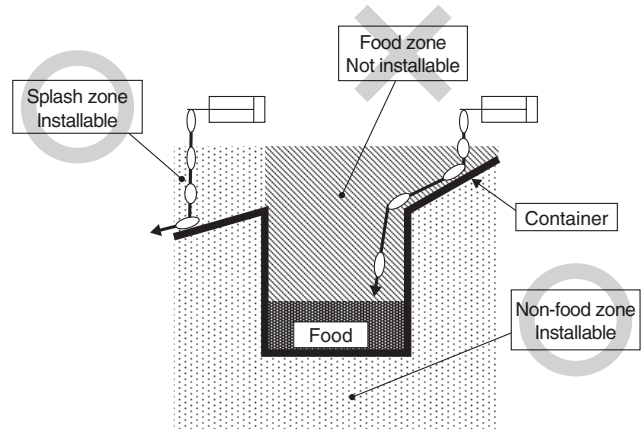

## 8 Anti-corrosive Treatment of Finger Symbol **-X81□**

- Special black chromium treatment
- The finger and guide use the martensitic stainless steel. When anti-corrosive measures better than the martensitic stainless steel level are required, use these series.

### How to Order

Standard model no. **- X81A**  
 Anti-corrosive treatment of finger

Standard model no. **- X81B**  
 Anti-corrosive treatment of finger and guide

### Specifications

Treatment	Special black chromium treatment
Specifications other than the above and dimensions	Same as those of the standard type



**9 With An Adjustable Opening/Closing Finger Positioning**

- Stroke can be adjusted to suit the workpiece
- 3 types of opening/closing finger stroke adjustments (Adjustable finger opening/closing position type, Adjustable finger opening position type, Adjustable finger closed position type)

**Various strokes**

- Standardized 3 stroke types and 2 stroke adjustment types for fine tuning

Bore size [mm]	Short stroke		Medium stroke		Long stroke	
	Full stroke	Stroke adjustable width	Full stroke	Stroke adjustable width	Full stroke	Stroke adjustable width
ø8	8 mm	Short Adjuster 4 mm Long Adjuster 8 mm	16 mm	Short Adjuster 6 mm Long Adjuster 10 mm	32 mm	Short Adjuster 12 mm Long Adjuster 22 mm
ø12	12 mm	Short Adjuster 8 mm Long Adjuster 12 mm	24 mm	Short Adjuster 8 mm Long Adjuster 14 mm	48 mm	Short Adjuster 18 mm Long Adjuster 28 mm
ø16	16 mm	Short Adjuster 10 mm Long Adjuster 14 mm	32 mm	Short Adjuster 8 mm Long Adjuster 18 mm	64 mm	Short Adjuster 16 mm Long Adjuster 36 mm
ø20	20 mm	Short Adjuster 8 mm Long Adjuster 18 mm	40 mm	Short Adjuster 10 mm Long Adjuster 20 mm	80 mm	Short Adjuster 20 mm Long Adjuster 40 mm

**How to Order**

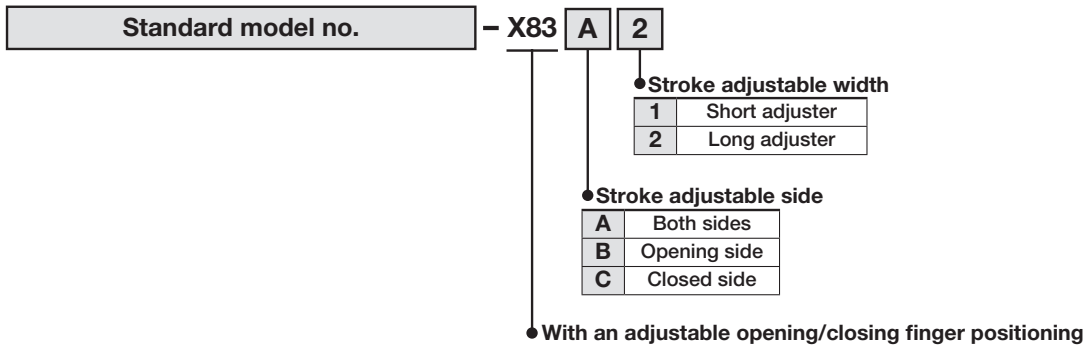

## 9 With An Adjustable Opening/Closing Finger Positioning

### Specifications

#### Finger Stroke Adjustable Width for Opening/Closing Position

[mm]

Model		Full stroke	Adjustable stroke width	A: Adjustable finger opening/closing position type		B: Adjustable finger opening position type	C: Adjustable finger closing position type
				Adjustable stroke width		Adjustable stroke width for opening position	Adjustable stroke width for closed position
				Closed position	Opening position		
MHF2-8D□	Short Adjuster (-X83□1)	8	4	0 to 4	4 to 8	4 to 8	0 to 4
	Long Adjuster (-X83□2)		8	0 to 8	0 to 8	0 to 8	0 to 8
MHF2-8D1□	Short Adjuster (-X83□1)	16	6	0 to 6	10 to 16	10 to 16	0 to 6
	Long Adjuster (-X83□2)		10	0 to 10	6 to 16	6 to 16	0 to 10
MHF2-8D2□	Short Adjuster (-X83□1)	32	12	0 to 12	20 to 32	20 to 32	0 to 12
	Long Adjuster (-X83□2)		22	0 to 22	10 to 32	10 to 32	0 to 22
MHF2-12D□	Short Adjuster (-X83□1)	12	8	0 to 8	4 to 12	4 to 12	0 to 8
	Long Adjuster (-X83□2)		12	0 to 12	0 to 12	0 to 12	0 to 12
MHF2-12D1□	Short Adjuster (-X83□1)	24	8	0 to 8	16 to 24	16 to 24	0 to 8
	Long Adjuster (-X83□2)		14	0 to 14	10 to 24	10 to 24	0 to 14
MHF2-12D2□	Short Adjuster (-X83□1)	48	18	0 to 18	30 to 48	30 to 48	0 to 18
	Long Adjuster (-X83□2)		28	0 to 28	20 to 48	20 to 48	0 to 28
MHF2-16D□	Short Adjuster (-X83□1)	16	10	0 to 10	6 to 16	6 to 16	0 to 10
	Long Adjuster (-X83□2)		14	0 to 14	2 to 16	2 to 16	0 to 14
MHF2-16D1□	Short Adjuster (-X83□1)	32	8	0 to 8	24 to 32	24 to 32	0 to 8
	Long Adjuster (-X83□2)		18	0 to 18	14 to 32	14 to 32	0 to 18
MHF2-16D2□	Short Adjuster (-X83□1)	64	16	0 to 16	48 to 64	48 to 64	0 to 16
	Long Adjuster (-X83□2)		36	0 to 36	28 to 64	28 to 64	0 to 36
MHF2-20D□	Short Adjuster (-X83□1)	20	8	0 to 8	12 to 20	12 to 20	0 to 8
	Long Adjuster (-X83□2)		18	0 to 18	2 to 20	2 to 20	0 to 18
MHF2-20D1□	Short Adjuster (-X83□1)	40	10	0 to 10	30 to 40	30 to 40	0 to 10
	Long Adjuster (-X83□2)		20	0 to 20	20 to 40	20 to 40	0 to 20
MHF2-20D2□	Short Adjuster(-X83□1)	80	20	0 to 20	60 to 80	60 to 80	0 to 20
	Long Adjuster (-X83□2)		40	0 to 40	40 to 80	40 to 80	0 to 40

\* Specifications and details other than those shown above are the same as those of the standard type.

### How to Adjust Finger Stroke

After adjusting the opening/closing width adjustment thread, tighten the nut to fix.

#### Nut Tightening Torque

Part no.	Thread size	Tightening torque [N·m]
MHF2-8D□-X83□□	M4 x 0.7	1.5
MHF2-8D□R-X83□□		
MHF2-12D□-X83□□	M5 x 0.8	3.0
MHF2-12D□R-X83□□		
MHF2-16D□-X83□□	M6 x 1.0	5.2
MHF2-16D□R-X83□□		
MHF2-20D□-X83□□	M8 x 1.25	12.5
MHF2-20D□R-X83□□		

### Warning

1. Adjust the stroke adjustment screw within the adjustable width.

If you adjust the adjustment screw beyond the maximum value, the adjustment screw may fall out and may cause damage to human bodies or equipment/devices.

2. Do not adjust stroke when air pressure is applied to the adjustment screw side.

If air pressure is applied to the adjustment screw, the adjustment screw may fall out in some adjustment statuses. When applying pressure, make sure the adjustment screw is tightened enough.

**9 With An Adjustable Opening/Closing Finger Positioning**

**Dimensions** (The dimensions below are the same as those of the standard type.)

Adjustable finger opening/closing position type: MHF2-□- **X83A1**  
**X83A2**

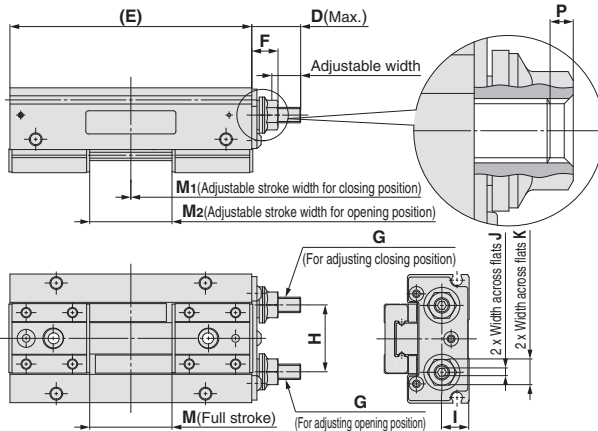

Adjustable finger opening position type/MHF2-□- **X83B1**  
**X83B2**

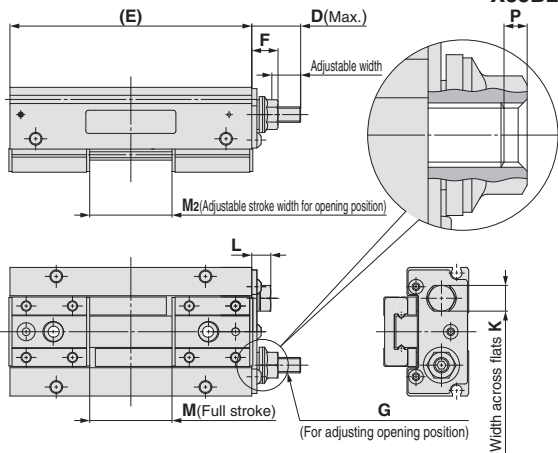

Adjustable finger closing position type/MHF2-□- **X83C1**  
**X83C2**

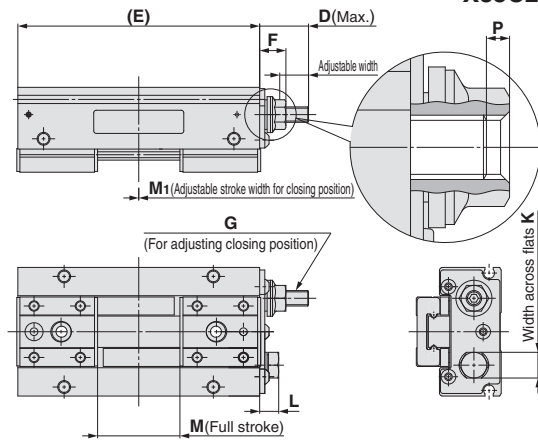

**Dimensions** (The □ in the table below indicates the symbol for stroke adjustable side (A: Adjustable finger opening/closing position type, B: Adjustable finger opening position type, or C: Adjustable finger closing position type).)

Model		A: Adjustable finger opening/closing position type		B: Adjustable finger opening position type		C: Adjustable finger closing position type		D	(E)	F	G	H	I	J	K	L	M	P
		M <sub>1</sub>	M <sub>2</sub>	M <sub>1</sub>	M <sub>2</sub>	M <sub>1</sub>	M <sub>2</sub>											
		□	□	□	□	□	□											
MHF2-8D□	-X83□1	0 to 4	4 to 8	—	4 to 8	0 to 4	—	9	36								8	
	-X83□2	0 to 8	0 to 8	—	0 to 8	0 to 8	—	12										
MHF2-8D1□	-X83□1	0 to 6	10 to 16	—	10 to 16	0 to 6	—	10	48	6.8	M4 x 0.7	15.8	5.9	2	7	4.6	16	1.8
	-X83□2	0 to 10	6 to 16	—	6 to 16	0 to 10	—	12										
MHF2-8D2□	-X83□1	0 to 12	20 to 32	—	20 to 32	0 to 12	—	13	72								32	
	-X83□2	0 to 22	10 to 32	—	10 to 32	0 to 22	—	18										
MHF2-12D□	-X83□1	0 to 8	4 to 12	—	4 to 12	0 to 8	—	12	52								12	
	-X83□2	0 to 12	0 to 12	—	0 to 12	0 to 12	—	14										
MHF2-12D1□	-X83□1	0 to 8	16 to 24	—	16 to 24	0 to 8	—	12	68	8.2	M5 x 0.8	20	7.7	2.5	8	5.4	24	2.3
	-X83□2	0 to 14	10 to 24	—	10 to 24	0 to 14	—	15										
MHF2-12D2□	-X83□1	0 to 18	30 to 48	—	30 to 48	0 to 18	—	18	104								48	
	-X83□2	0 to 28	20 to 48	—	20 to 48	0 to 28	—	23										
MHF2-16D□	-X83□1	0 to 10	6 to 16	—	6 to 16	0 to 10	—	15	72								16	
	-X83□2	0 to 14	2 to 16	—	2 to 16	0 to 14	—	17										
MHF2-16D1□	-X83□1	0 to 8	24 to 32	—	24 to 32	0 to 8	—	14	94	10.2	M6 x 1	26	10.6	3	10	7.4	32	2.4
	-X83□2	0 to 18	14 to 32	—	14 to 32	0 to 18	—	19										
MHF2-16D2□	-X83□1	0 to 16	48 to 64	—	48 to 64	0 to 16	—	18	142								64	
	-X83□2	0 to 36	28 to 64	—	28 to 64	0 to 36	—	28										
MHF2-20D□	-X83□1	0 to 8	12 to 20	—	12 to 20	0 to 8	—	18	86								20	
	-X83□2	0 to 18	2 to 20	—	2 to 20	0 to 18	—	23										
MHF2-20D1□	-X83□1	0 to 10	30 to 40	—	30 to 40	0 to 10	—	18	114	13.2	M8 x 1.25	33	13	4	12	9.9	40	3
	-X83□2	0 to 20	20 to 40	—	20 to 40	0 to 20	—	23										
MHF2-20D2□	-X83□1	0 to 20	60 to 80	—	60 to 80	0 to 20	—	23	174								80	
	-X83□2	0 to 40	40 to 80	—	40 to 80	0 to 40	—	33										

# MHF2 Series

## 10 Actuator Position Sensor Compatible Type

Symbol  
**-X7050**

The stroke position is output with an analog signal.

Repeatability: 0.1 mm

Direct mounting is possible.

Analog output, Switch output

### Applicable Actuator Position Sensors (Full stroke length detectable)

Stroke	Bore size			
	ø8	ø12	ø16	ø20
Short stroke	Not available	D-MP025□	D-MP025□	D-MP025□
Medium stroke	D-MP025□	D-MP025□	D-MP025□	D-MP025□
Long stroke	D-MP025□	D-MP050□	D-MP050□	D-MP050□

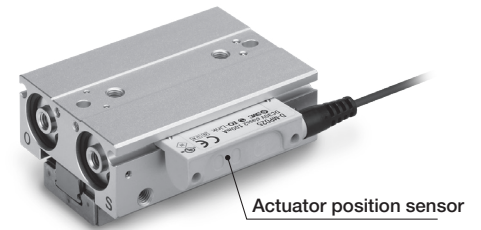

**Specifications: Same as those of the standard type**

### How to Order

MHF2 - □□□□ - X7050

- Actuator position sensor compatible type
- Refer to the standard model number on page 7.

- \* The short stroke type cannot be used for the ø8 because the mounting dimension is too short.
- \* The actuator position sensor is not included with the product. It must be ordered separately.
- \* D-M9 series auto switches cannot be used.

- \* For details on the actuator position sensor (D-MP series), refer to the Web Catalog.



**10 Actuator Position Sensor Compatible Type**

Symbol  
**-X7050**

**Actuator Position Sensor Mounting Position (Guide)**

This is a guideline for the mounting position when detecting the full stroke length.

\* Adjust the sensor after confirming the operating conditions in the actual setting.

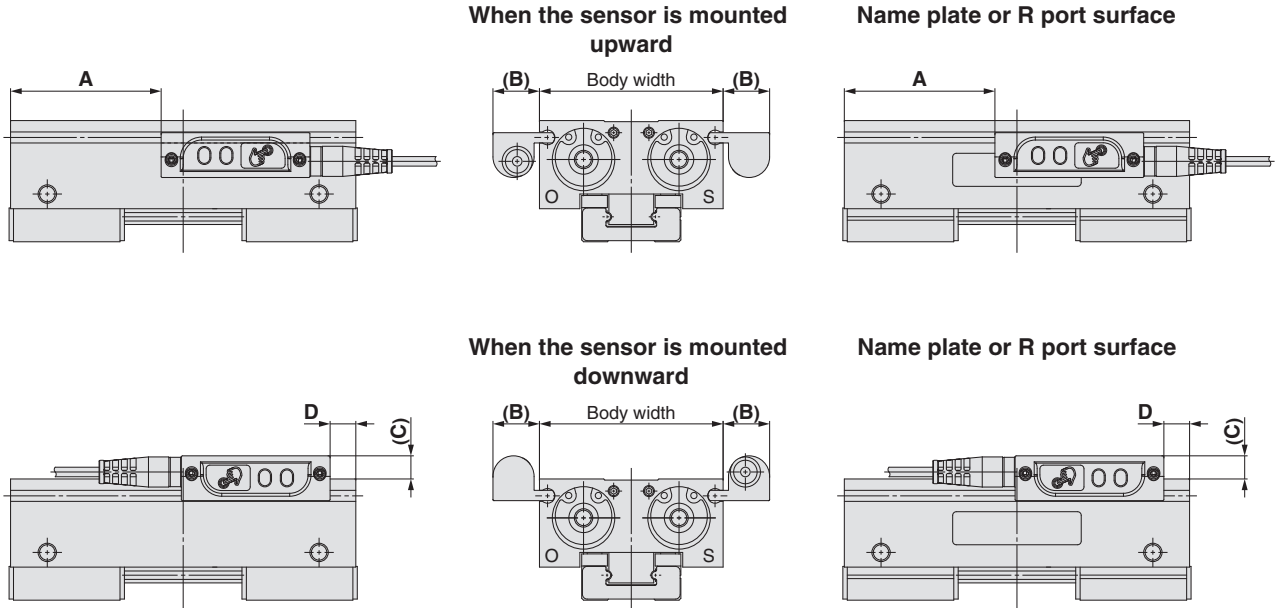

**Actuator Position Sensor Mounting Position Guide**

Model	A	(B)	(C)	D	Applicable actuator position sensor
MHF2-8D1(R)-X7050	5.5 to 7.5	(15)	(8.5)	0 to 1	D-MP025□
MHF2-8D2(R)-X7050	26.5 to 31.5	(15)	(8.5)	0 to 3.5	
MHF2-12D(R)-X7050	6 to 11.5	(15)	(8)	0 to 4	
MHF2-12D1(R)-X7050	19.5 to 27.5	(15)	(8)	0 to 6.5	
MHF2-12D2(R)-X7050	24 to 39	(15)	(8)	0 to 14	D-MP050□
MHF2-16D(R)-X7050	19 to 31.5	(14)	(7)	0 to 11	D-MP025□
MHF2-16D1(R)-X7050	36 to 44.5	(14)	(7)	0 to 13.5	
MHF2-16D2(R)-X7050	56 to 71	(14)	(7)	5.5 to 20.5	D-MP050□
MHF2-20D(R)-X7050	31 to 43	(14)	(5.5)	1 to 13	D-MP025□
MHF2-20D1(R)-X7050	54 to 56	(14)	(5.5)	15.5 to 17.5	
MHF2-20D2(R)-X7050	80 to 87	(14)	(5.5)	22 to 29	D-MP050□

• The □ in the applicable actuator position sensor part numbers indicates the lead wire type. For details, refer to the actuator position sensor in the Web Catalog.

**For the Side Piping Type**

When the sensor is mounted on the same surface as the piping port on the side piping type, there will be interference between the sensor and the fitting and the speed controller, resulting in restricted use.

Model	Sensor: Upward	Sensor: Downward
MHF2-8D1R-X7050	x	○
MHF2-8D2R-X7050	x	○
MHF2-12DR-X7050	x	○
MHF2-12D1R-X7050	x	○
MHF2-12D2R-X7050	x	○
MHF2-16DR-X7050	x	○
MHF2-16D1R-X7050	x	○
MHF2-16D2R-X7050	x	○
MHF2-20DR-X7050	○	○
MHF2-20D1R-X7050	○	○
MHF2-20D2R-X7050	○	○

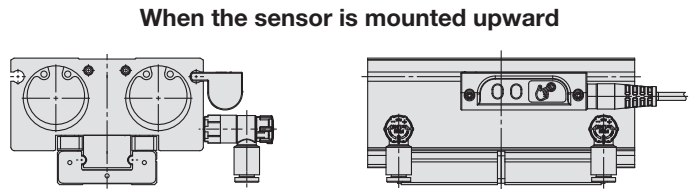



# MHF2 Series

## Specific Product Precautions 1

Be sure to read this before handling the products. Refer to the back cover for safety instructions. For air gripper and auto switch precautions, refer to the “Handling Precautions for SMC Products” and the “Operation Manual” on the SMC website: <https://www.smcusa.com>

### Mounting

#### Warning

1. Do not scratch or dent the air gripper by dropping or bumping it when mounting.  
Even a slight deformation can cause inaccuracy or malfunction.
2. Tighten the screw within the specified torque range when mounting the attachment.  
Tightening with a torque above the limit can cause malfunction, while insufficient tightening can cause slippage and dropping.

#### How to Mount Attachment to the Finger

Make sure to mount the attachments on fingers with the tightening torque in the table below by using bolts, etc., for the female threads on fingers.

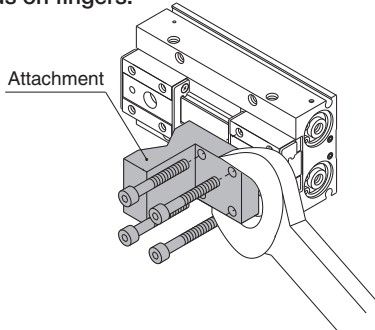

Refer to the next page for how to locate the finger and attachment.

Model	Bolt	Max. tightening torque [N·m]
MHF2-8D□	M2.5 x 0.45	0.36
MHF2-12D□	M3 x 0.5	0.63
MHF2-16D□	M4 x 0.7	1.5
MHF2-20D□	M4 x 0.7	1.5

3. Tighten the screw within the specified torque range when mounting the air gripper.  
Tightening with a torque above the limit can cause malfunction, while insufficient tightening can cause slippage and dropping.

#### How to Mount Air Grippers

##### Top mounting (Body tapped)

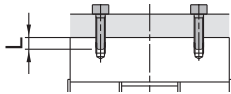

Model	Bolt	Max. tightening torque [N·m]	Max. screw-in depth L [mm]
MHF2-8D	M3 x 0.5	0.95	7
MHF2-12D	M4 x 0.7	2.2	10
MHF2-16D	M5 x 0.8	4.5	12
MHF2-20D	M6 x 1	7.8	15

##### Lateral mounting (Body tapped)

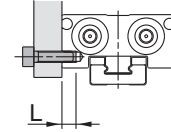

Model	Bolt	Max. tightening torque [N·m]	Max. screw-in depth L [mm]
MHF2-8D	M3 x 0.5	0.63	4
MHF2-12D	M4 x 0.7	1.5	5
MHF2-16D	M5 x 0.8	3	5.5
MHF2-20D	M6 x 1	5.2	6

##### Bottom mounting (Body tapped, body through-hole)

###### ● Body tapped

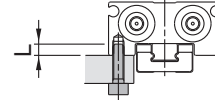

Model	Bolt	Max. tightening torque [N·m]	Max. screw-in depth L [mm]
MHF2-8D	M3 x 0.5	0.63	4
MHF2-12D	M4 x 0.7	1.5	5
MHF2-16D	M5 x 0.8	3	5.5
MHF2-20D	M6 x 1	5.2	6

###### ● Body through-hole

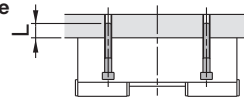

Model	Bolt	Max. tightening torque [N·m]	Screw-in depth L [mm]
MHF2-8D	M2.5 x 0.45 <sup>*1</sup>	0.36	4
MHF2-12D	M3 x 0.5 <sup>*1</sup>	0.63	5.2
MHF2-16D	M4 x 0.7	1.5	—
MHF2-20D	M5 x 0.8	3	—

<sup>\*1</sup> When MHF2-8D□ and MHF2-12D□ are mounted body through-hole, use the attached special bolts.

### Operating Environment

#### Caution

Use caution for the anti-corrosiveness of the linear guide unit.

Martensitic stainless steel is used for the finger guide rail. However, the anti-corrosiveness of this steel is inferior to that of austenitic stainless steel. In particular, rust may be generated in environments where water droplets are likely to adhere due to condensation, etc.



## MHF2 Series

# Specific Product Precautions 2

Be sure to read this before handling the products. Refer to the back cover for safety instructions. For air gripper and auto switch precautions, refer to the “Handling Precautions for SMC Products” and the “Operation Manual” on the SMC website: <https://www.smcusa.com>

### Handling

## ⚠ Caution

### How to Locate Finger and Attachment

#### ● Positioning in the finger's open/close direction

Position the finger and the attachment by inserting the finger's pin into the attachment's pin insertion hole.

Provide the following pin insertion hole dimensions: shaft-basis fitting dimension **C** for the open/close direction; slotted hole with relief **B** for the cross direction.

#### ● Positioning in the finger's cross direction

Perform the positioning from the reference plane of the finger and the side A of the attachment.

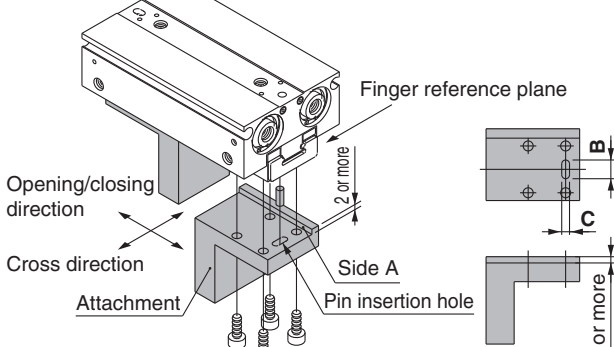

Finite orbit type guide is used in the actuator finger part. By using this, when there are inertial force which cause by movements or rotation to the actuator, steel ball will move to one side and this will cause a large resistance and degrade the accuracy. When there are inertial force which cause by movements or rotation to the actuator, operate the finger to full stroke.

Especially in long stroke type, the accuracy of the finger may degrade.

### UNIT CONVERSIONS

	unit	conversion	result
length	m	x 3.28	ft
	mm	x 0.04	in
mass	g	x 0.04	oz
	cm <sup>3</sup>	÷ 16.387	in <sup>3</sup>
volume	L	x 61.024	in <sup>3</sup>
	speed	mm/s	÷ 25.4
pressure	MPa	x 145	psi
	kPa	÷ 6.895	psi
temperature	°C	x1.8 then add 32	°F
torque	N·m	x 0.738	ft·lb
force	N	÷ 4.448	lbf
flow	L/min	÷ 28.317	cfm



## Safety Instructions

These safety instructions are intended to prevent hazardous situations and/or equipment damage. These instructions indicate the level of potential hazard with the labels of “Caution,” “Warning” or “Danger.” They are all important notes for safety and must be followed in addition to International Standards (ISO/IEC)\*1), and other safety regulations.



**Caution:** Caution indicates a hazard with a low level of risk which, if not avoided, could result in minor or moderate injury.



**Warning:** Warning indicates a hazard with a medium level of risk which, if not avoided, could result in death or serious injury.



**Danger:** Danger indicates a hazard with a high level of risk which, if not avoided, will result in death or serious injury.

- \*1) ISO 4414: Pneumatic fluid power – General rules relating to systems.
- ISO 4413: Hydraulic fluid power – General rules relating to systems.
- IEC 60204-1: Safety of machinery – Electrical equipment of machines. (Part 1: General requirements)
- ISO 10218-1: Manipulating industrial robots – Safety. etc.



### Warning

#### 1. The compatibility of the product is the responsibility of the person who designs the equipment or decides its specifications.

Since the product specified here is used under various operating conditions, its compatibility with specific equipment must be decided by the person who designs the equipment or decides its specifications based on necessary analysis and test results. The expected performance and safety assurance of the equipment will be the responsibility of the person who has determined its compatibility with the product. This person should also continuously review all specifications of the product referring to its latest catalog information, with a view to giving due consideration to any possibility of equipment failure when configuring the equipment.

#### 2. Only personnel with appropriate training should operate machinery and equipment.

The product specified here may become unsafe if handled incorrectly. The assembly, operation and maintenance of machines or equipment including our products must be performed by an operator who is appropriately trained and experienced.

#### 3. Do not service or attempt to remove product and machinery/equipment until safety is confirmed.

1. The inspection and maintenance of machinery/equipment should only be performed after measures to prevent falling or runaway of the driven objects have been confirmed.
2. When the product is to be removed, confirm that the safety measures as mentioned above are implemented and the power from any appropriate source is cut, and read and understand the specific product precautions of all relevant products carefully.
3. Before machinery/equipment is restarted, take measures to prevent unexpected operation and malfunction.

#### 4. Contact SMC beforehand and take special consideration of safety measures if the product is to be used in any of the following conditions.

1. Conditions and environments outside of the given specifications, or use outdoors or in a place exposed to direct sunlight.
2. Installation on equipment in conjunction with atomic energy, railways, air navigation, space, shipping, vehicles, military, medical treatment, combustion and recreation, or equipment in contact with food and beverages, emergency stop circuits, clutch and brake circuits in press applications, safety equipment or other applications unsuitable for the standard specifications described in the product catalog.
3. An application which could have negative effects on people, property, or animals requiring special safety analysis.
4. Use in an interlock circuit, which requires the provision of double interlock for possible failure by using a mechanical protective function, and periodical checks to confirm proper operation.



### Caution

#### 1. The product is provided for use in manufacturing industries.

The product herein described is basically provided for peaceful use in manufacturing industries.

If considering using the product in other industries, consult SMC beforehand and exchange specifications or a contract if necessary. If anything is unclear, contact your nearest sales branch.

### Limited warranty and Disclaimer/ Compliance Requirements

The product used is subject to the following “Limited warranty and Disclaimer” and “Compliance Requirements”.

Read and accept them before using the product.

#### Limited warranty and Disclaimer

1. The warranty period of the product is 1 year in service or 1.5 years after the product is delivered, whichever is first.\*2) Also, the product may have specified durability, running distance or replacement parts. Please consult your nearest sales branch.
2. For any failure or damage reported within the warranty period which is clearly our responsibility, a replacement product or necessary parts will be provided. This limited warranty applies only to our product independently, and not to any other damage incurred due to the failure of the product.
3. Prior to using SMC products, please read and understand the warranty terms and disclaimers noted in the specified catalog for the particular products.

##### \*2) Vacuum pads are excluded from this 1 year warranty.

A vacuum pad is a consumable part, so it is warranted for a year after it is delivered. Also, even within the warranty period, the wear of a product due to the use of the vacuum pad or failure due to the deterioration of rubber material are not covered by the limited warranty.

#### Compliance Requirements

1. The use of SMC products with production equipment for the manufacture of weapons of mass destruction (WMD) or any other weapon is strictly prohibited.
2. The exports of SMC products or technology from one country to another are governed by the relevant security laws and regulations of the countries involved in the transaction. Prior to the shipment of a SMC product to another country, assure that all local rules governing that export are known and followed.



### Caution

#### SMC products are not intended for use as instruments for legal metrology.

Measurement instruments that SMC manufactures or sells have not been qualified by type approval tests relevant to the metrology (measurement) laws of each country. Therefore, SMC products cannot be used for business or certification ordained by the metrology (measurement) laws of each country.

o o o o e c



r s e s s c s c o r s c o c o