



# Vacuum Gripper Unit for Collaborative Robots

Compliant with the CRX Series  
**FANUC CORPORATION**  
collaborative robot

**Plug and Play**  
configuration for immediate use

**FANUC CRX plug-in software** Easy programming



**ZXP7□21-X1**



More information  
can be viewed here.

P-E20-27

# Plug and Play

## Vacuum Gripper Unit

for Collaborative Robots

FANUC CORPORATION

CRX-10*i*A, 10*i*A/L compliant

Operate by simply connecting 1 compressed air supply tube and an electrical wiring M8 connector.

- Integrated vacuum ejector, air supply/release valve, pressure sensor, and cups
- Standards: Conforming to ISO 9409-1-50-4-M6
- FANUC CRX plug-in software (Refer to page 5.)



Robot mounting flange  
(Conforming to ISO 9409-1-50-4-M6)

Parallel pin

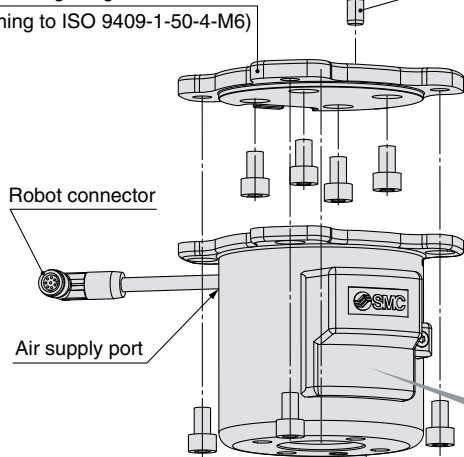

Parallel pin

O-ring

Cup mounting flange  
(Conforming to ISO 9409-1-50-4-M6)

Cups with adapter

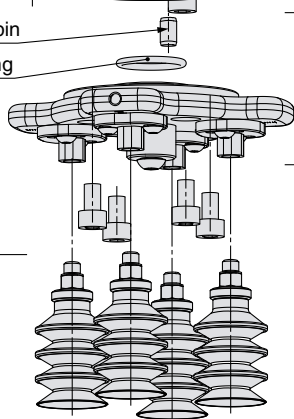

### Specifications

	Standards	Conforming to ISO 9409-1-50-4-M6
Common	Applicable fluid	Air
	Operating temperature range [°C]	5 to 50
	Weight [g] <sup>*3</sup>	794 (581)
	Max. work load [kg] <sup>*4</sup>	7
	Air pressure supply (P) port	One-touch fitting (ø6)
	Power supply voltage [V]	24 VDC ±10%
Vacuum ejector	Max. vacuum pressure [kPa] <sup>*5</sup>	-84
	Suction flow rate [L/min (ANR)] <sup>*5</sup>	17
	Air consumption [L/min (ANR)] <sup>*5</sup>	57
	Supply pressure range [MPa]	0.3 to 0.55
Pressure sensor	Standard supply pressure [MPa] <sup>*6</sup>	0.5
	Rated pressure range [kPa]	0 to -101
	Accuracy (Ambient temperature at 25°C)	±2% F.S.
	Linearity	±0.4% F.S.
	Repeatability	±0.2% F.S.

■ Included parts: Robot mounting flange, Parallel pin, Mounting bolt, Cups with adapter\*1, Plug\*2, Piping tube (ø6)

- \*1 Included only with cups
- \*2 Included only for the ZXP7A
- \*3 The weight in brackets refers to the weight of the product without a cup mounting flange. Add the weight of the suction cups with adapter for the weight with cups.
- \*4 May be restricted depending on the cup diameter, mounting orientation, or workpiece. Please use within the max. work load. Suction and transfer exceeding the max. work load may result in reduced vacuum pressure due to air leakage.
- \*5 Values are at the standard supply pressure and based on SMC's measurement standards. They depend on atmospheric pressure (weather, altitude, etc.) and the measurement method.
- \*6 This value indicates the pressure right before the air pressure supply (P) port when vacuum is generated. The pressure right before the P port of the vacuum gripper unit when vacuum is generated may fall below 0.5 MPa due to the air supply capacity, piping size, and the amount of air being consumed by other devices being operated simultaneously.

### Details of internal parts

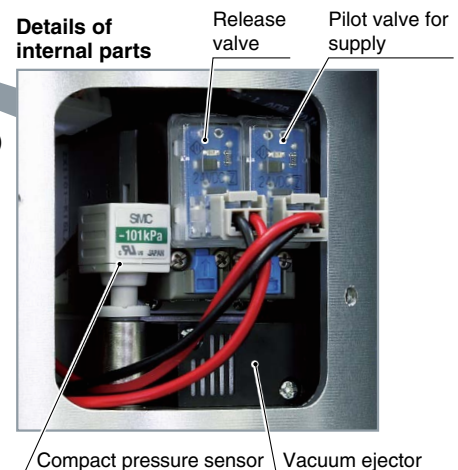

Release valve

Pilot valve for supply

Compact pressure sensor

Vacuum ejector

# Adsorption Unit Variations

The number of cups can be changed.



1 cup

2 cups

4 cups

The cup type can be changed. (For details on selectable cups, refer to "How to Order.")



Flat (ø8), Silicone rubber

Bellows (ø20), NBR

Thin flat (ø16), NBR

Flat (ø32), Silicone rubber

Flat (ø32), Urethane rubber



ø32, 2.5-stage, Silicone rubber

ø25, 5.5-stage, Silicone rubber

ø25, 5.5-stage, Silicone rubber With vacuum saving valve



Vacuum saving valve  
ZP2V Series  
(To be ordered separately)  
Applicable part no.: ZP2V-B6-05

\* The silicone material is compliant with the FDA (U.S. Food and Drug Administration) regulation 21CFR§177.

■ The cup pitch can be changed.

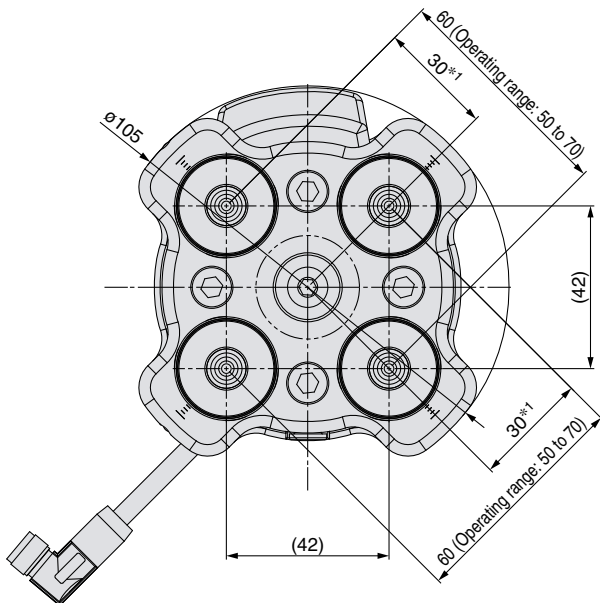

\*1 Operating range: 25 to 35 (When a cup is mounted in the center)  
As interference between cups may occur depending on the cup diameter, select the cup diameter according to the pitch to be used.

■ The cup with flange can be used separately

(if using an external vacuum source).

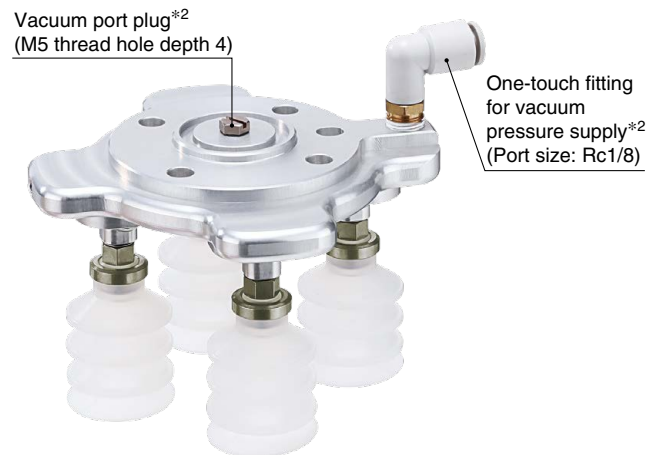

\*2 When using a cup with flange, be sure to order a One-touch fitting for vacuum pressure supply (part number: KQ2L08-01NS) and a vacuum port plug (part number: M-5P) separately.

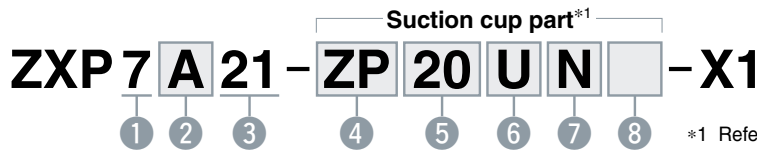

\*1 Refer to the table below for the applicable cups.

**1 Unit size**

Symbol	Size
7	75 mm

**2 Cup flange shape**

Symbol	Shape
A	42 mm x 42 mm
N	Without flange*2

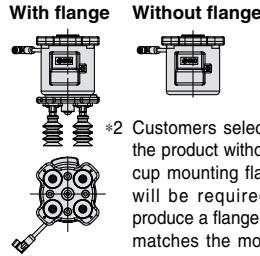

\*2 Customers selecting the product without a cup mounting flange will be required to produce a flange that matches the mounting dimensions on their own.

**3 Compatible manufacturer**

Symbol	Robot manufacturer
21	FANUC: CRX-10iA, 10iA/L

**4 Cup series**

Symbol	Series
ZP	Basic
ZP3P	Bellows type for film packaging workpieces
Nil	Without cup

**5 Cup diameter**

Symbol	Cup diameter	Symbol	Cup diameter
08	ø8	25	ø25
10	ø10	B25	ø25
13	ø13	B30	ø30
16	ø16	32	ø32
20	ø20	Nil	Without cup

**6 Cup form**

Symbol	Type
U	Flat
C	Flat with rib
B	Bellows
UT	Thin flat
J	Multistage bellows
JT2	2.5-stage bellows
JT5	5.5-stage bellows
Nil	Without cup

**7 Cup material**

Symbol	Material
N	NBR
S	Silicone rubber (White)*3
U	Urethane rubber
F	FKM
SF	Silicone rubber (Blue)*3
Nil	Without cup

\*3 The silicone material is compliant with the FDA (U.S. Food and Drug Administration) regulation 21CFR§177.

**8 Attachment\*4**

Symbol	Attachment
Nil	With (guide) attachment
M	With mesh attachment

\*4 Only applicable to the cup form "JT"

\*1

**Suction Cup Part Numbers and Weight**



**Applicable cups**

4	5	6	7	8
Cup series	Cup diameter	Cup form	Cup material	Attachment
ZP	08	U	□	
ZP	08	B	□	
ZP	10	UT	□	
ZP	13	UT	□	
ZP	16	UT	□	
ZP	10	U	□	
ZP	13	U	□	
ZP	16	U	□	
ZP	20	U	□	
ZP	25	U	□	
ZP	32	U	□	
ZP	10	C	□	
ZP	13	C	□	
ZP	16	C	□	
ZP	20	C	□	
ZP	25	C	□	
ZP	32	C	□	
ZP	10	B	□	
ZP	13	B	□	
ZP	16	B	□	
ZP	20	B	□	
ZP	25	B	□	
ZP	32	B	□	
ZP	20	UT	□	
ZP	16	J	□	
ZP	B25	J	□	
ZP	B30	J	□	
ZP3P	20	JT2	SF	
ZP3P	20	JT2	SF	M
ZP3P	32	JT2	SF	
ZP3P	32	JT2	SF	M
ZP3P	20	JT5	SF	
ZP3P	25	JT5	SF	
ZP3P	32	JT5	SF	

**Cup part numbers**

Part no.	Cup with adapter				Adapter unit Vacuum inlet: (Male thread M6 x 1)	Cup unit	
	Weight by cup material (g/cup)						
	N (NBR)	S/SF (Silicone)	U (Urethane)	F (FKM)			
ZPT08U□-A6	4	4	4	4	ZPT1-A6	ZP08U□	
ZPT08B□-A6	4	4	4	4		ZP08B□	
ZPT10UT□-A6	4	4	4	4		ZP10UT□	
ZPT13UT□-A6	4	4	4	4		ZP13UT□	
ZPT16UT□-A6	4	4	4	4	ZP16UT□		
ZPG10U□-7A-X2	7	7	7	7	ZPT2-7A-X2	ZP10U□	
ZPG13U□-7A-X2	7	7	7	8		ZP13U□	
ZPG16U□-7A-X2	7	7	7	8		ZP16U□	
ZPG20U□-7A-X2	9	10	10	10		ZP20U□	
ZPG25U□-7A-X2	10	10	10	11	ZPT3-7A-X2	ZP25U□	
ZPG32U□-7A-X2	10	11	11	12		ZP32U□	
ZPG10C□-7A-X2	7	7	7	7		ZP10C□	
ZPG13C□-7A-X2	7	7	7	7		ZP13C□	
ZPG16C□-7A-X2	7	7	7	8	ZPT2-7A-X2	ZP16C□	
ZPG20C□-7A-X2	9	10	10	11		ZP20C□	
ZPG25C□-7A-X2	10	10	10	11		ZP25C□	
ZPG32C□-7A-X2	10	11	11	12		ZP32C□	
ZPG10B□-7A-X2	7	7	7	8	ZPT3-7A-X2	ZP10B□	
ZPG13B□-7A-X2	7	8	8	8		ZP13B□	
ZPG16B□-7A-X2	8	8	8	9		ZP16B□	
ZPG20B□-7A-X2	11	11	11	13		ZP20B□	
ZPG25B□-7A-X2	11	12	12	14	ZPT2-7A-X2	ZP25B□	
ZPG32B□-7A-X2	14	15	15	18		ZP32B□	
ZPG20UT□-7A-X2	4	4	4	4		ZP20UT□	
ZPG16J□-7A-X2	8	8	8	9		ZP2-16J□	
ZPGB25J□-7A-X2	14	15	15	18	ZPT1-A6	ZP2-B25J□	
ZPGB30J□-7A-X2	18	19	19	25		ZP2-B30J□	
ZP3PG20JT2SF-7A-X2	—	21	—	—		ZPT2-7A-X2	ZP3P-20JT2SF-WM
ZP3PG20JT2SF-M-7A-X2	—	21	—	—			ZP3P-20JT2SF-WM
ZP3PG32JT2SF-7A-X2	—	48	—	—	ZPT3-7A-X2		ZP3P-32JT2SF-WM
ZP3PG32JT2SF-M-7A-X2	—	48	—	—			ZP3P-32JT2SF-WM
ZP3PG20JT5SF-7A-X2	—	23	—	—		ZPT1-A6	ZP3P-20JT5SF-WG
ZP3PG25JT5SF-7A-X2	—	25	—	—			ZP3P-25JT5SF-WG
ZP3PG32JT5SF-7A-X2	—	54	—	—	ZPT2-7A-X2		ZP3P-32JT5SF-WG
ZP3PG32JT5SF-M-7A-X2	—	54	—	—			ZP3P-32JT5SF-WG

\* Refer to the **Web Catalog** for details on suction cups.

Input the material symbol ("N," "S," "U," or "F") into the □ in the part number.

## Model Selection

### Exhaust Characteristics\*1

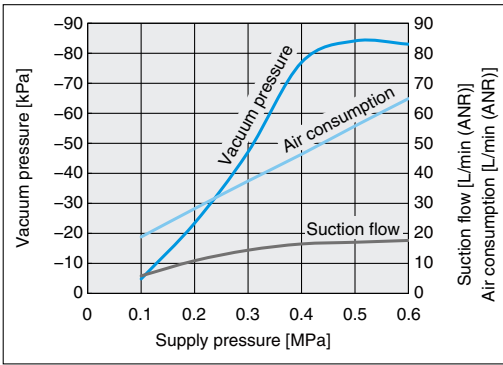

### Flow Rate Characteristics

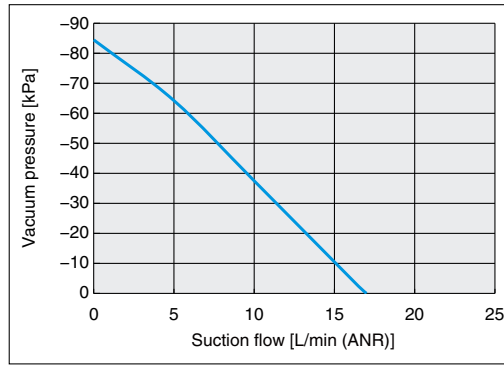

\*1 The exhaust characteristics are different when the vacuum-saving valve (ZP2V-B6-05) is mounted.  
For details, refer to "8.3 Suction cup precautions" in the operation manual.

## Dimensions

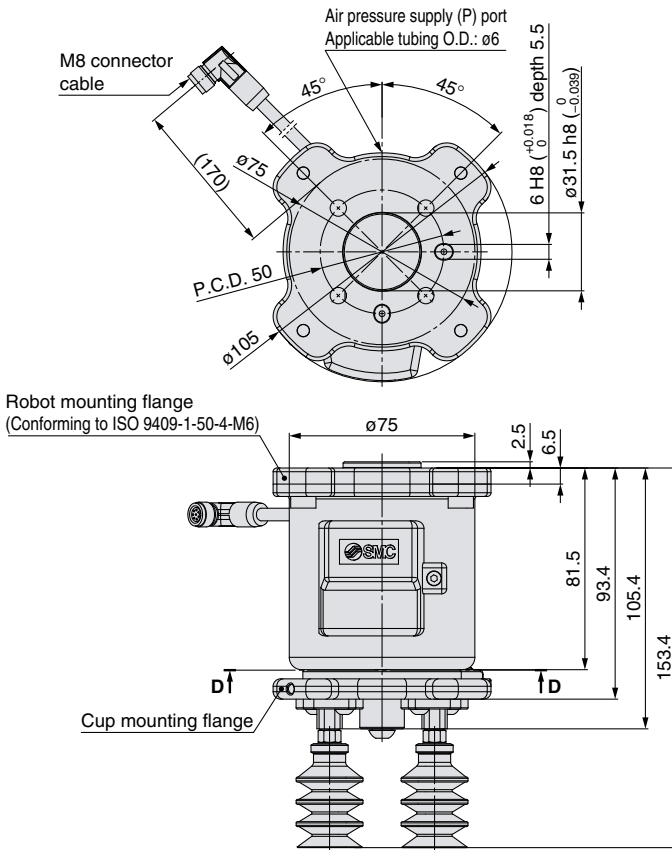

### Circuit diagram

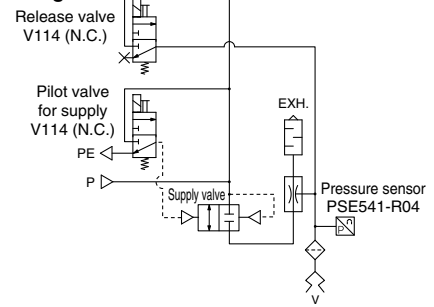

### Cup mounting flange Replacement part number: ZXP7-PFL1-A-X1

(Refer to the figure below for items. Quantities are shown in the parentheses.)

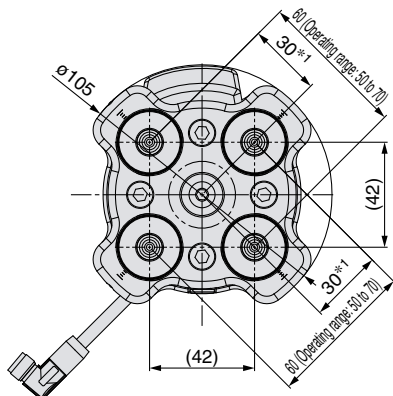
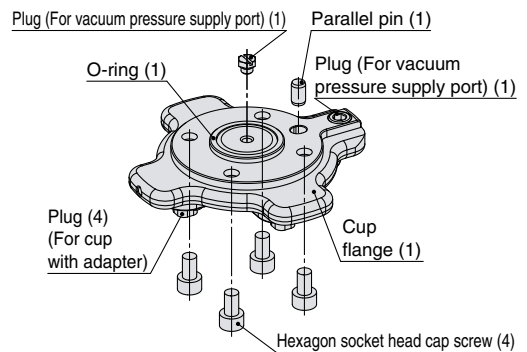

\*1 Operating range: 25 to 35 (When a cup is mounted in the center)  
As interference between cups may occur depending on the cup diameter, select the cup diameter according to the pitch to be used.

### Without cup mounting flange

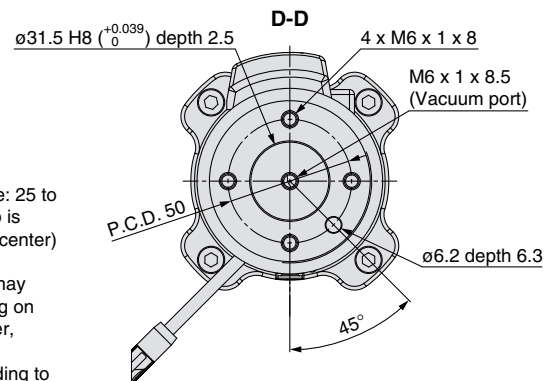

\* The vacuum port doesn't come with mesh.

\* The dimensions and mounting method described in this drawing (example) are for the following part number: ZXP7A21-ZPB25JS-X1

# FANUC CRX Plug-in Software

More information  
on the FANUC CRX  
plug-in software  
can be viewed here.



## Easy programming

By using SMC's vacuum gripper unit plug-in software, the dedicated setting window can be displayed and dedicated instructions can be executed.

The CRX plug-in software can be easily installed by inserting a USB stick containing the software (provided by SMC) into the control device.

\* Please download the CRX plug-in software from the SMC website, and save it to a USB memory.



FANUC Robot  
CRX-10iA

R-30iB Mini Plus



Tablet TP



USB memory  
(Saved copy of FANUC CRX plug-in software)

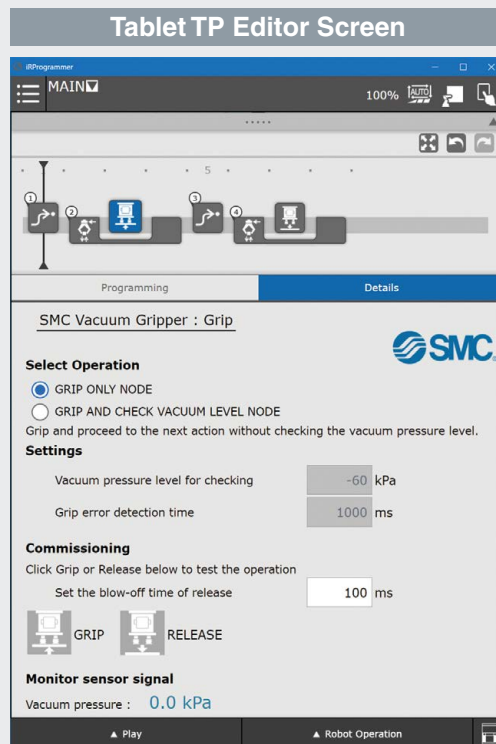



# ZXP7□21-X1

## Specific Product Precautions

Be sure to read this before handling the products. For safety instructions and vacuum equipment precautions, refer to the “Handling Precautions for SMC Products” and the “Operation Manual” on the SMC website.

### Handling

#### Caution

1. Strictly observe the precautions on vacuum equipment and safety when using the product. Additionally, select a cup size and material suitable to both the workpiece to be adsorbed and the atmosphere. Take safety measures so that any accident, such as the dropping of a workpiece, does not occur during adsorption transfer. For details, refer to the Web Catalog.
2. Use the product within the specification range. Use exceeding the compressed air pressure or voltage may result in serious damage due to reduced product performance.
3. Exhaust air is released from the opening in the product. Therefore, this exhaust air opening must not be blocked or restricted.

### Mounting

#### Caution

1. For details on the mounting method, refer to the Operation Manual.
2. Tighten to the specified tightening torque. If the tightening torque is exceeded, the body and the mounting screws may break. However, insufficient torque may cause displacement of the body and loosening of the mounting screws.
3. Do not drop, strike, or apply excessive impact to this product.  
Doing so may result in damage to the internal parts of the body, solenoid valve, or pressure sensor. In some cases, this damage may result in a malfunction.
4. Hold the body when handling the product. Do not pull excessively on the M8 connector cable or pinch the cable when lifting the body. Failure to do so may result in damage to the solenoid valve or pressure sensor. In some cases, this damage may result in a failure or malfunction.
5. The bolts may loosen due to the operating conditions and environment. Be sure to conduct maintenance such as tightening the bolts periodically.

### Wiring

#### Caution

1. Avoid repeatedly bending or stretching the M8 connector cable as well as applying force to it.
2. Do not wire while energizing the product. Doing so may result in damage to the internal parts of the solenoid valve or pressure sensor. In some cases, this damage may result in a malfunction.
3. Do not disassemble the M8 connector cable or make any modifications, including additional machining. Doing so may cause human injury and/or an accident.

### Piping

#### Caution

##### 1. Flushing of the inside of the pipes

Before piping is connected, it should be thoroughly blown out with air (flushing) or washed to remove chips, cutting oil, and other debris from inside the pipe.

##### 2. Tube attachment

- Take a tube having no flaws on its periphery and cut it off at a right angle. When cutting the tube, use tube cutters TK-1, 2, 3, 5, or 6. Do not use pliers, nippers, scissors, etc. If cutting is done with tools other than tube cutters, the tube may be cut diagonally or become flattened, etc., making a secure installation impossible, and causing problems such as the tube pulling out after installation or air leakage. Allow some extra length in the tube.
- Grasp the tube and push it in slowly, inserting it securely all the way into the fitting.
- After inserting the tube, pull on it lightly to confirm that it will not come out. If it is not installed securely all the way into the fitting, this can cause problems such as air leakage or the tube pulling out.

##### 3. Tube detachment

- Push in the release button sufficiently, pushing its collar equally around the circumference.
- Pull out the tube while holding down the release button so that it does not come out. If the release button is not pressed down sufficiently, there will be increased bite on the tube and it will become more difficult to pull it out.
- When the removed tube is to be used again, cut off the portion which has been chewed before reusing it. If the chewed portion of the tube is used as is, this can cause trouble such as air leakage or difficulty in removing the tube.

##### 4. Other Tube Brands

When using other than SMC brand tube, confirm that the following specifications are satisfied with respect to the tube outside diameter tolerance.

- Nylon tube within  $\pm 0.1$  mm
- Soft nylon tube within  $\pm 0.1$  mm
- Polyurethane tube within  $\pm 0.15$  mm, within  $-0.2$  mm

Do not use tube which do not meet these outside diameter tolerances. It may not be possible to connect them, or they may cause other trouble, such as air leakage or the tube pulling out after connection.

##### 5. Piping

- Do not apply unnecessary forces, such as twisting, pulling, moment loads, vibration, impact, etc., on fittings or tubing. This will cause damage to fittings and will crush, burst, or release tubing.
- Do not lift the product by the piping after the tube is connected. Doing so may result in damage to the One-touch tube fitting. For details, refer to the “Handling Precautions for SMC Products” on the SMC website.



## Vacuum Gripper Unit for Collaborative Robots

**⚠ Safety Instructions** Be sure to read the "Handling Precautions for SMC Products" (M-E03-3) and "Operation Manual" before use.

**SMC Corporation**