

AC Servo Motor

Motorless Type

Electric Actuator Rod Type



- Max. force: 12000 N, Work load: 1200 kg, Max. stroke: 1000 mm
- Can be mounted in accordance with ISO 15552
- Modify the force/speed specifications
(Change specifications by changing or removing the reducer)
- Motorless type
- An auto switch can be mounted



Motorless Type

Can be used with your current motor and driver!

Manufacturers of compatible motors: 7 companies

- Mitsubishi Electric Corporation
- YASKAWA Electric Corporation
- SANYO DENKI CO., LTD.
- NIDEC SANKYO CORPORATION
- KEYENCE CORPORATION
- FUJI ELECTRIC CO., LTD.
- Delta Electronics, Inc.



LEY100 Series



Work load

Max. work load (Horizontal)

LEY100DT9L (Lead 2) **1200 kg (6 times)**

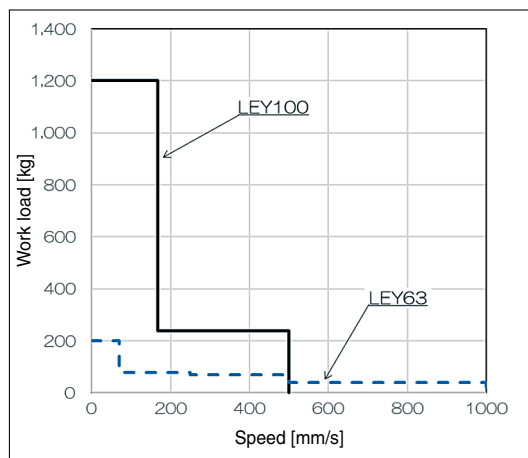

Compared with the existing model LEY63□L
(Max. horizontal work load 200 kg)

Max. work load (Vertical)

LEY100DT9L (Lead 2) **200 kg (1.7 times)**

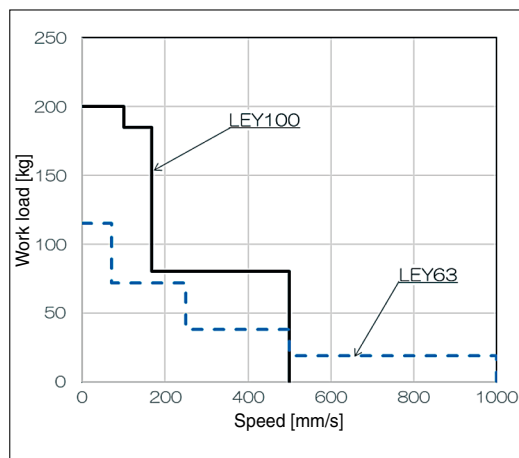

Compared with the existing model LEY63□L
(Max. vertical work load 115 kg)

Max. force

LEY100DT9L (Lead 2) **12000 N (3.5 times)**

Compared with the existing model LEY63□L (Max. 3343 N)

Applicable stroke

LEY100D **100 to 1000 mm (1.2 times)**

Compared with the existing model LEY63□ (Stroke 100 to 800 mm)

AC Servo Motor Rod Type Series Variations

Work load (Horizontal/Vertical)

1200 kg/200 kg

Up to 1000 mm

LEY100

200 kg/115 kg

Up to 800 mm

LEY63

60 kg/46 kg

Up to 500 mm

LEY25/32

Short Stroke Long

Can be mounted in accordance with ISO 15552

The ISO cylinder (C96 $\varnothing 80$) and flange mounting bracket are now standardized.

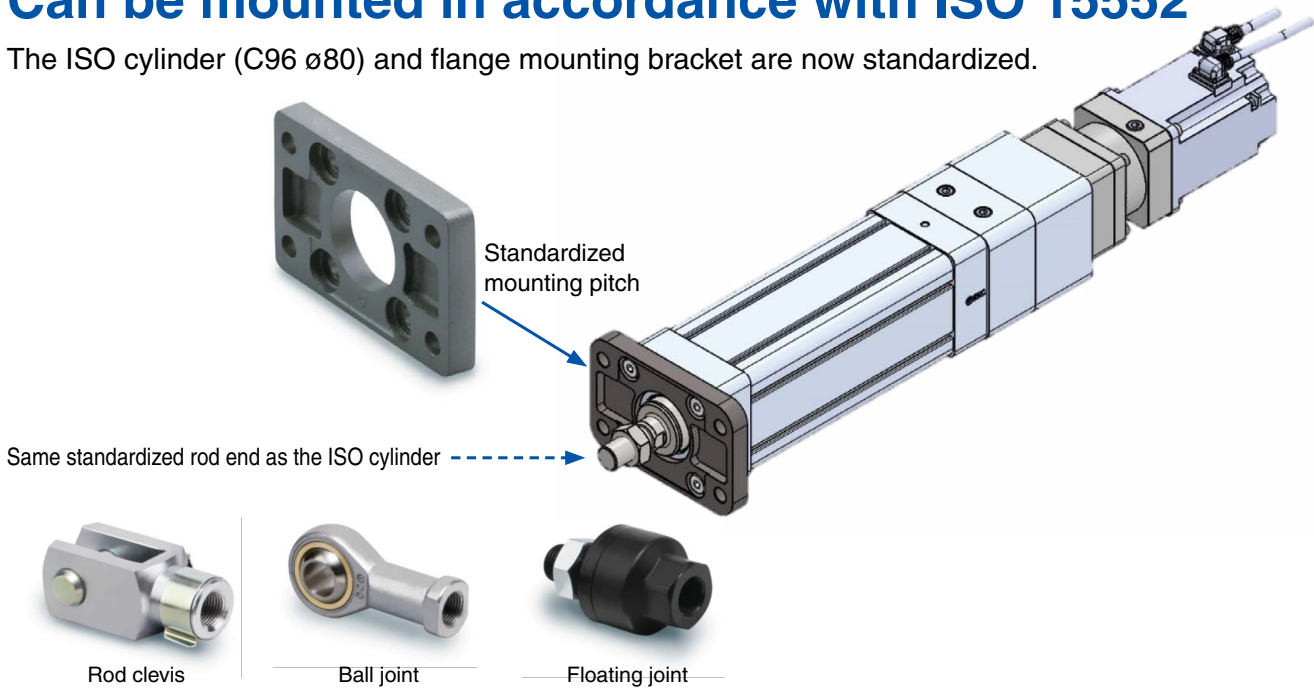

Modify the force/speed specifications

The max. force and max. speed settings can be changed by changing the reducer.

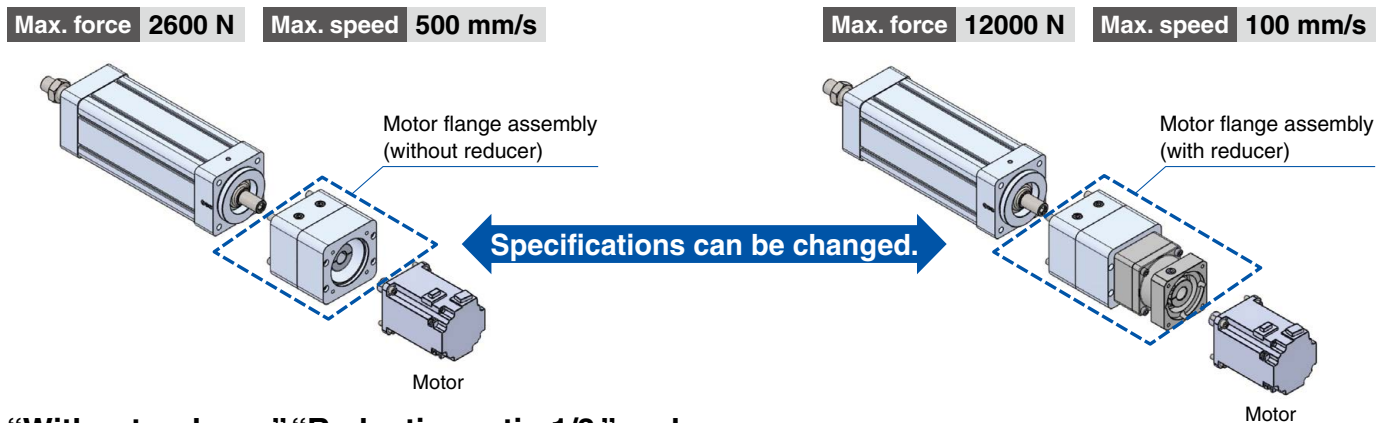

“Without reducer,” “Reduction ratio 1/3,” and “Reduction ratio 1/5” can be selected.

An auto switch can be mounted

An auto switch can be mounted from the front of the groove.

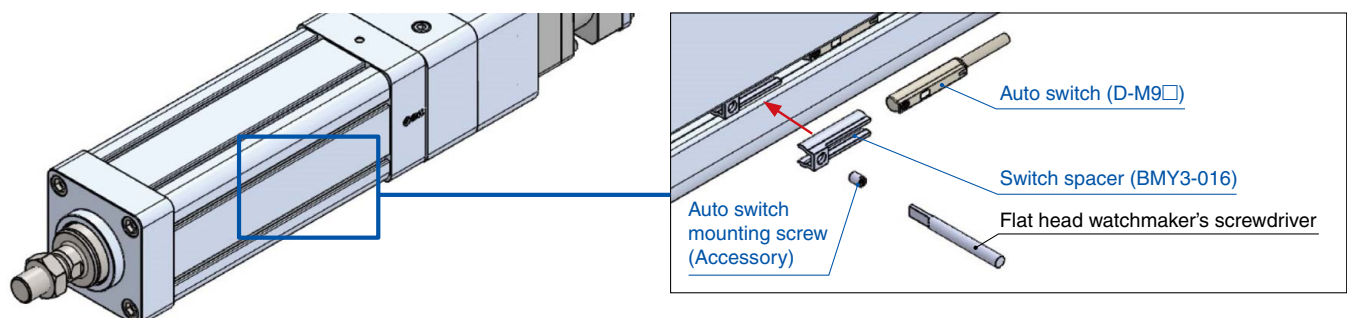

Application examples

Servo-driven press machine

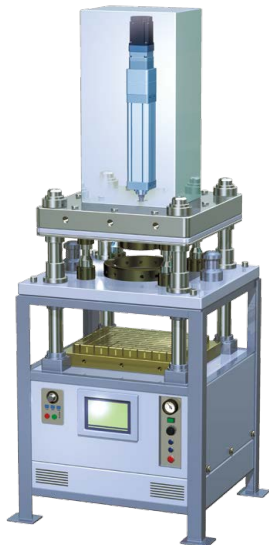

Replenishment unit (spring extended piston control)

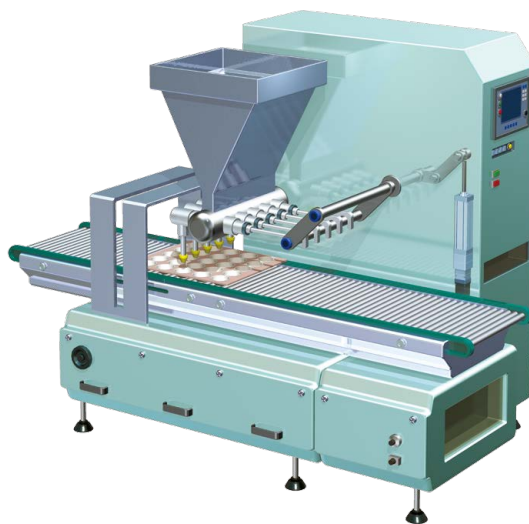

Motorless Type

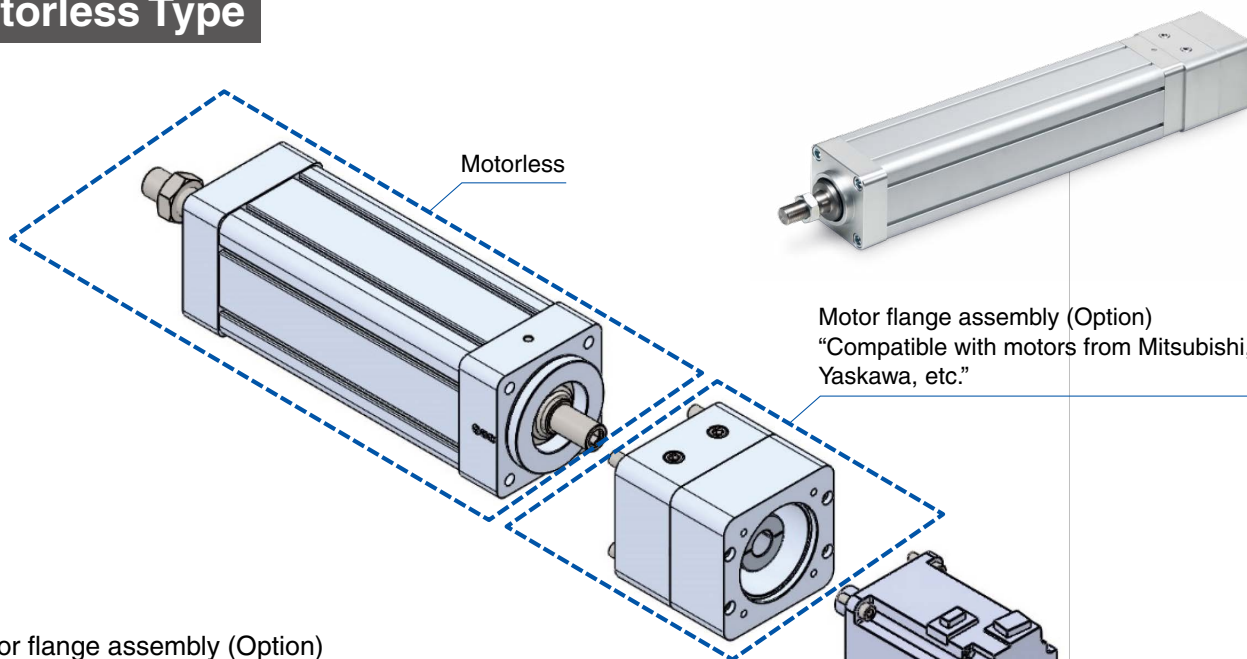

Motor flange assembly (Option)
“Standard-compatible motor”

Manufacturer	Series	Type	NN
Mitsubishi Electric Corporation	MELSERVO-J4	HG-KR	●
	MELSERVO-J5	HK-KT	●
YASKAWA Electric Corporation	Σ-V	SGMJV	●
	Σ-7	SGM7J	●
SANYO DENKI CO., LTD.	SANMOTION R	R2	●
NIDEC SANKYO CORPORATION	S-FLAG	MX	●
KEYENCE CORPORATION	SV	SV-M/SV-B	●
FUJI ELECTRIC CO., LTD.	ALPHA5/7	GYS/GYB/GYG	●
Delta Electronics, Inc.	ASDA-A2	ECMA	●

(Motor: Provided by the customer)

Model Selection

* Motorless specification is lead 10 only

Speed-Vertical Work Load Graph/Required Conditions for the Regeneration Option

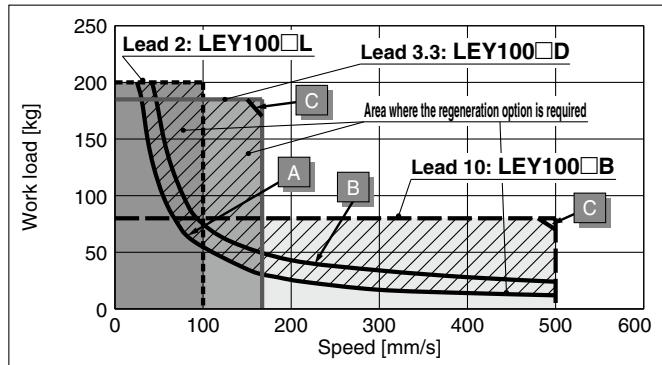

Required conditions for the regeneration option

* The regeneration option is required when using the product above the regeneration line in the graph. (It must be ordered separately.)

Regeneration Option Models

Size	Model	Note
LEY100□	LEC-MR-RB-032	A area
	LEC-MR-RB-12	B area
		C area

Speed-Horizontal Work Load Graph/Required Conditions for the Regeneration Option

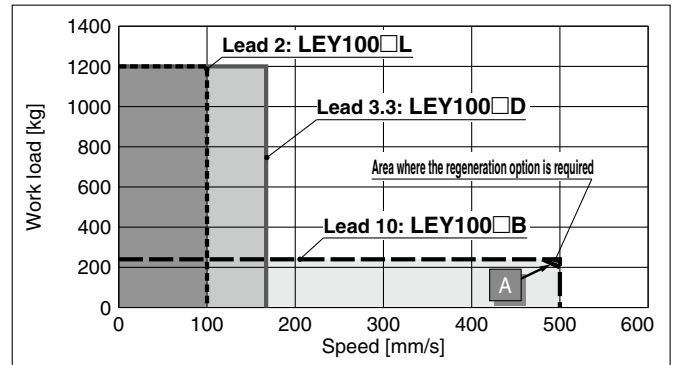

Required conditions for the regeneration option

* The regeneration option is required when using the product above the regeneration line in the graph. (It must be ordered separately.)

Regeneration Option Models

Size	Model	Note
LEY100□	LEC-MR-RB-032	A area

Force Conversion Graph (Guide) For the LECSS-T

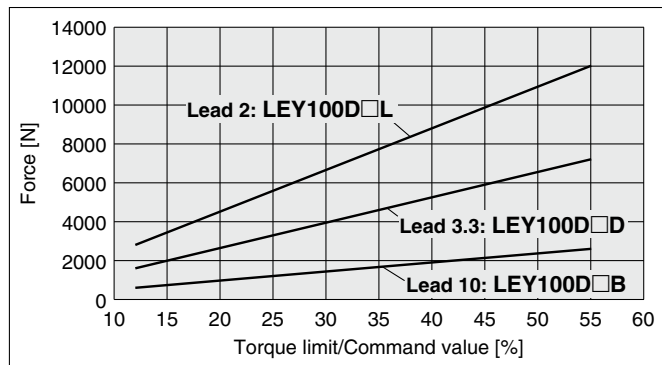

Torque limit/Command value [%]	Duty ratio [%]	Continuous pushing time [min]
25 or less	100	—
30	90	6.00 or less
40	50	1.23 or less
50	30	0.57 or less
55	20	0.25 or less

Load-Acceleration/Deceleration Chart

Max. acceleration/deceleration (Horizontal)

[mm/s²]

Lead	Symbol	[mm]	Work load [kg]											
			100	200	300	400	500	600	700	800	900	1000	1100	1200
B	10	3000	2000 ^{*1}	—										
D	3.3	2370	2250	2120	2000	1870	1750	1620	1500	1370	1250	1120	1000	
L	2	1900	1800	1700	1600	1500	1420	1350	1280	1210	1140	1070	1000	

*1 The max. work load can be set to any weight up to 240 kilograms.

Max. acceleration/deceleration (Vertical)

[mm/s²]

Lead	Symbol	[mm]	Work load [kg]									
			20	40	60	80	100	120	140	160	180	200
B	10	2500	2000	1500	1000	—						
D	3.3	2370	2200	2020	1850	1680	1510	1340	1170	1000 ^{*2}	—	
L	2	1880	1770	1660	1550	1450	1360	1270	1180	1090	1000	—

*2 The max. work load can be set to any weight up to 185 kilograms.

Force-Stroke Table

Force [N]	Stroke [mm]										
	0	100	200	300	400	500	600	700	800	900	1000
Force [N]	12000	12000	12000	12000	12000	12000	11000	8900	6900	5600	4600

Electric Actuator/ Rod Type

LEY100 Series

Size **100**



How to Order

Driver
LECS Series

LEY 100 D T9 B - 200 - S 2 B2

1 2 3 4 5 6 7 8 9 10 11 12

1 Size
100

2 Motor mounting position
D In-line

3 Motor type

Symbol	Type	Output [W]	Actuator size	Compatible drivers
T9	AC servo motor (Absolute encoder)	750	100	LECSB2-T9 LECS2-T9 LECSS2-T9 LECSN2-T9(-□)

4 Lead [mm]

Symbol	LEY100
B	10
D	3.33*1
L	2*2

5 Stroke [mm]

100	100
to	to
1000	1000

6 Motor option

Nil	Without option
B	With lock

7 Rod end thread

Nil	Rod end female thread
M	Rod end male thread (1 rod end nut is included.)

*1 Screw lead 10 mm, reducer ratio [1:3]
*2 Screw lead 10 mm, reducer ratio [1:5]

* For details, refer to the applicable stroke table below.

8 Mounting*3 *4

Symbol	Type	Motor mounting position
Nil	Ends tapped	●
L	Foot	●
F	Flange	●

*3 The mounting bracket is shipped together with the product but does not come assembled.
*4 Do not mount using the "flange" or "ends tapped" options for the horizontal type with one end secured.

9 Cable type*5

Nil	Without cable
S	Standard cable
R	Robotic cable (Flexible)

*5 A motor cable and encoder cable are included with the product. (A lock cable is also included if motor option "B: With lock" is selected.)

10 Cable length [m]*6

Nil	Without cable
2	2
5	5
A	10

*6 The length of the encoder, motor, and lock cables are the same.

11 Driver type

	Compatible drivers	Power supply voltage [V]
Nil	Without driver	
B2	LECSB2-T9/Pulse input (Absolute encoder)	200 to 240
C2	LECS2-T9/CC-Link (Absolute encoder)	200 to 230
S2	LECSS2-T9/SSCNET/H (Absolute encoder)	200 to 230
92	LECSN2-T9-9/EtherNet/IP (Absolute encoder)	200 to 240
E2	LECSN2-T9-E/EtherCAT (Absolute encoder)	200 to 240
P2	LECSN2-T9-P/PROFINET (Absolute encoder)	200 to 240
N2	LECSN2-T9/Without network card (Absolute encoder)	200 to 240

12 I/O cable length [m]*7

Nil	Without cable
H	Without cable (Connector only)
1	1.5

*7 When "Nil: Without driver" is selected for the driver type, only "Nil: Without cable" can be selected. Refer to the **Web Catalog** if an I/O cable is required.

Applicable Stroke Table

Size	Stroke [mm]										Manufacturable stroke range
	100	200	300	400	500	600	700	800	900	1000	
100	●	●	●	●	●	●	●	●	●	●	100 to 1000

* Please contact SMC for non-standard strokes as they are produced as special orders.

Specifications

Model		LEY100D□L	LEY100D□D	LEY100D□B
Stroke [mm]		100, 200, 300, 400, 500, 600, 700, 800, 900, 1000		
Work load [kg]	Horizontal*1	1200	1200	240
	Vertical	200	185	80
Rated force [N]/Set value*2: 25%*3		5500	3300	1100
Max. force [N]/Set value*2: 55%*3		12000	7200	2600
Max. speed [mm/s]*4	Up to 500	100	167	500
	600	74	123	370
	700	57	95	285
	800	45	75	225
	900	36	60	180
	1000	30	50	150
Pushing speed [mm/s]*5		20 or less		
Max. acceleration/deceleration [mm/s ²]		2000	3000	
Positioning repeatability [mm]		0.02		
Lost motion [mm]*6		0.10		
Screw lead [mm]		10		
Reduction ratio		1/5	1/3	—
Lead [mm]		2	3.3	10
Impact/Vibration resistance [m/s ²]*7		50/20		
Actuation type		Ball screw		
Guide type		Sliding bushing (Piston rod)		
Operating temperature range [°C]		5 to 40		
Operating humidity range [%RH]		90 or less (No condensation)		
Motor output [W]/Size [mm]		750/□80		
Motor type		AC servo motor (200 VAC)		
Power consumption [W]*8	Horizontal	250		
	Vertical	450		
Standby power consumption when operating [W]*9	Horizontal	20		
	Vertical	30		
Max. instantaneous power consumption [W]*10		1100		
Type*11		Non-magnetizing lock		
Holding force [N]		4860	2925	1080
Power consumption [W] at 20°C*12		10		
Rated voltage [V]		24 VDC ⁰ / _{-10%}		

*1 This is the max. value of the horizontal work load. An external guide is necessary to support the load. The actual work load changes according to the condition of the external guide. Confirm the load using the actual device.

*2 Set values for the driver

*3 The force setting range (set values for the driver) for the force control with the torque control mode. The force and duty ratio change according to the set value. Set it while referencing the "Force Conversion Graph" on page 4.

When the control equivalent to the pushing operation of the LECP6 series controller is performed, select the LECS2-T or LECSB2-T driver.

The point table no. input method is used for the LECSB2-T. When selecting the LECS2-T, combine it with a Simple Motion module (manufactured by Mitsubishi Electric Corporation) which has a pushing operation function.

*4 The allowable speed changes according to the stroke. Set the number of rotations according to speed.

*5 The allowable collision speed for collision with the workpiece with the torque control mode

*6 A reference value for correcting errors in reciprocal operation

*7 Impact resistance: No malfunction occurred when the actuator was tested with a drop tester in both an axial direction and a perpendicular direction to the lead screw. (The test was performed with the actuator in the initial state.)

Vibration resistance: No malfunction occurred in a test ranging between 45 to 2000 Hz. The test was performed in both an axial direction and a perpendicular direction to the lead screw. (The test was performed with the actuator in the initial state.)

*8 The power consumption (including the driver) is for when the actuator is operating.

*9 The standby power consumption when operating (including the driver) is for when the actuator is stopped in the set position during the operation.

*10 The max. instantaneous power consumption (including the driver) is for when the actuator is operating.

*11 Only when motor option "With lock" is selected

*12 For an actuator with lock, add the power consumption for the lock.

LEY100 Series

AC Servo Motor

Size 100

Construction

In-line motor type: LEY100

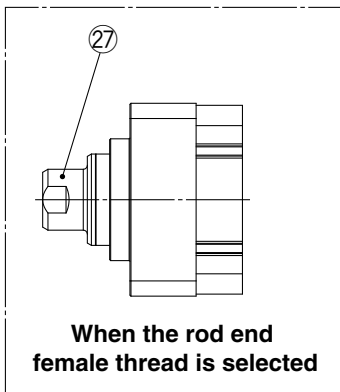
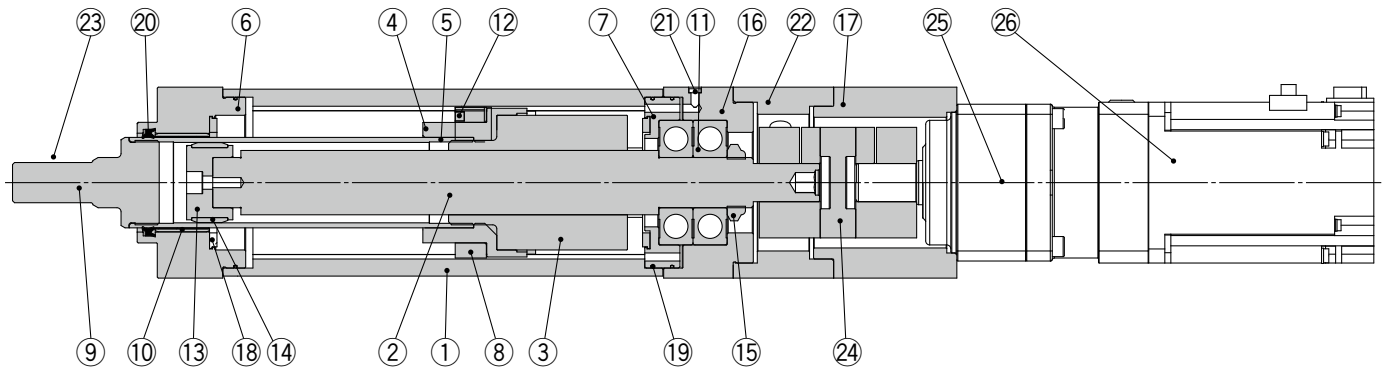

Component Parts

No.	Description	Material	Note
1	Body	Aluminum alloy	Anodized
2	Screw shaft	Alloy steel	
3	Ball screw nut	Alloy steel	
4	Piston	Aluminum alloy	
5	Piston rod	Alloy steel	Hard chrome plating
6	Rod cover	Aluminum alloy	Anodized
7	Bearing holder	Aluminum alloy	
8	Rotation stopper	Synthetic resin	
9	Socket (Male thread)	Alloy steel	Nickel plating
10	Bushing	Bearing alloy	
11	Bearing	—	
12	Magnet	—	
13	Wear ring holder	Aluminum alloy	
14	Wear ring	Synthetic resin	

No.	Description	Material	Note
15	Anti-loosening nut	Alloy steel	
16	Motor block	Aluminum alloy	Anodized
17	Motor flange	Aluminum alloy	Anodized
18	Bumper	Urethane	
19	O-ring	NBR	
20	Scraper	NBR	
21	Sintered element	Stainless steel	
22	Motor adapter	Aluminum alloy	Anodized
23	Nut	Alloy steel	Zinc chromating
24	Coupling	—	
25	Reducer	—	
26	Motor	—	
27	Socket (Female thread)	Alloy steel	Nickel plating

Replacement Parts/Grease Pack

Applied portion	Order no.
Piston rod	GR-S-010 (10 g)
	GR-S-020 (20 g)

* Apply grease to the piston rod periodically.
Grease should be applied when 1 million cycles or 200 km have been reached, whichever comes first.

Dimensions: In-line Motor

LEY100D□

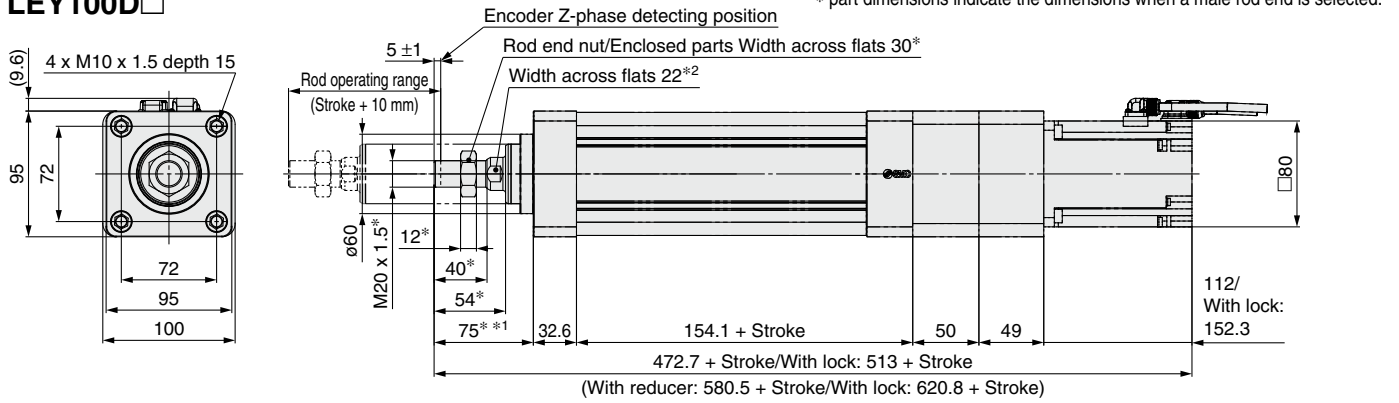

Rod end female thread: LEY100DT9□-□□□□

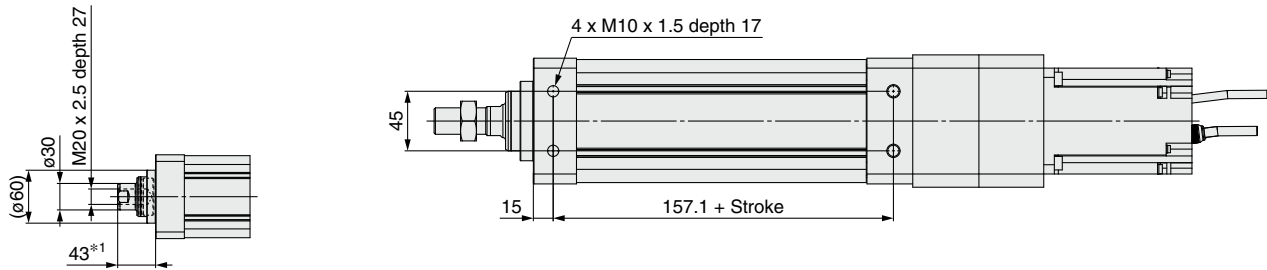

With reducer: LEY100DT9(D/L)-□□□□

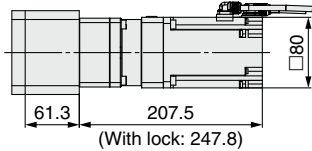

Rod flange shape: LEY100DT9□-□□□□F

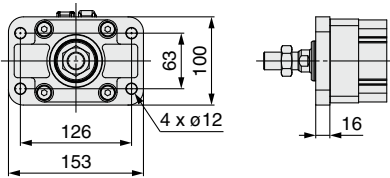

Foot: LEY100DT9□-□□□□L

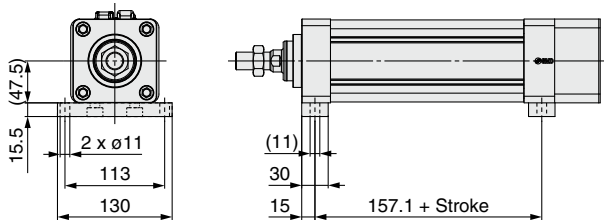

*1 The dimension in the figure is the first Z-phase detecting position.
 *2 The orientation of the square-width width across flats at the end of the rod differs for each product.

Stroke and Product Weight

Stroke	100	200	300	400	500	600	700	800	900	1000
Product weight	12.7	14.4	16.0	17.7	19.3	21.0	22.6	24.2	25.9	27.5

Additional Weight

With reducer		[kg]
Motor option	With lock	1.0
Rod end thread	Male thread	0.11
	Nut	0.05
Mounting	Foot	1.1
	Flange	0.8

Motorless Type

Electric Actuator/ Rod Type

LEY100 Series

Size 100



RoHS

How to Order

Motorless Type **LEY 100 D NN B - 200**

①
②
③
④
⑤
⑥
⑦

① Size
100

② Motor mounting position
D In-line

③ Motor type*1

Symbol	Type	Note
NN	ø80 - M5 thread hole	—

④ Lead [mm]

Symbol	LEY100
B	10

*1 A motor adapter and motor flange are not included.

⑤ Stroke [mm]

100	100
to	to
1000	1000

* For details, refer to the applicable stroke table below.

⑥ Rod end thread

Nil	Rod end female thread
M	Rod end male thread (1 rod end nut is included.)

⑦ Mounting*2 *3

Symbol	Type	Motor mounting position
		In-line
Nil	Ends tapped	●
L	Foot	●
F	Flange	●

*2 The mounting bracket is shipped together with the product but does not come assembled.

*3 Do not mount using the "flange" or "ends tapped" options for the horizontal type with one end secured.

Applicable Stroke Table

Size	Stroke [mm]										Manufacturable stroke range
	100	200	300	400	500	600	700	800	900	1000	
100	●	●	●	●	●	●	●	●	●	●	100 to 1000

* Please contact SMC for non-standard strokes as they are produced as special orders.

Compatible Motors

Manufacturer	Series	Type	NN
Mitsubishi Electric Corporation	MELSERVO-J4	HG-KR	●
	MELSERVO-J5	HK-KT	●
YASKAWA Electric Corporation	Σ-V	SGMJV	●
	Σ-7	SGM7J	●
SANYO DENKI CO., LTD.	SANMOTION R	R2	●
NIDEC SANKYO CORPORATION	S-FLAG	MX	●
KEYENCE CORPORATION	SV	SV-M/SV-B	●
FUJI ELECTRIC CO., LTD.	ALPHA5/ALPHA7	GYS/GYB/GYG	●
Delta Electronics, Inc.	ASDA-A2	ECMA	●

Specifications

- * The values in this specifications table are the allowable values of the actuator body with the standard motor mounted.
- * Do not use the actuator so that it exceeds these values.

Model		LEY100DNNB	
Actuator specifications	Stroke [mm]	100, 200, 300, 400, 500, 600, 700, 800, 900, 1000	
	Work load [kg]	Horizontal* ¹	240/1200 [When equipped with reducer (reduction ratio 1/5)]
		Vertical	80/200 [When equipped with reducer (reduction ratio 1/5)]
	Rated force [N]/Set value: Rated torque 87%* ²		1100/5500 [When equipped with reducer (reduction ratio 1/5)]
	Max. force [N]/Set value: Max. torque 192%* ²		2600/12000 [When equipped with reducer (reduction ratio 1/5)]
	Max. speed [mm/s]* ³	Up to 500	500
		600	370
		700	285
		800	225
		900	180
		1000	150
	Pushing speed [mm/s]* ⁴		20 or less
	Max. acceleration/deceleration [mm/s ²]		3000/2000 [When equipped with reducer (reduction ratio 1/5)]
	Positioning repeatability [mm]		±0.02
Lost motion [mm]* ⁵		0.1 or less	
Screw lead [mm]		10	
Impact/Vibration resistance [m/s ²]* ⁶		50/20	
Actuation type		Ball screw	
Guide type		Sliding bushing (Piston rod)	
Operating temperature range [°C]		5 to 40	
Operating humidity range [%RH]		90 or less (No condensation)	
Other specifications* ⁷	Actuation unit weight [kg] (* [ST]: Stroke)	2.80 + (7.50 x 10 ⁻³) x [ST]	
	Other inertia [kg·cm]	0.047	
	Friction coefficient	0.05	
	Mechanical efficiency	0.9	
Reference motor spec.	Motor shape	□80	
	Motor type	AC servo motor	
	Rated output capacity [W]	750	
	Rated torque [N·m]	2.4	
	Rated rotation [rpm]	3000	

- *1 This is the max. value of the horizontal work load. An external guide is necessary to support the load (Friction coefficient of guide: 0.1 or less). The actual work load changes according to the condition of the external guide. Confirm the load using the actual device.
- *2 The force setting range for the force control (Speed control mode, Torque control mode)
The force changes according to the set value. Set it with reference to the "Force Conversion Graph (Guide)" on page 4.
- *3 The allowable speed changes according to the stroke.
- *4 The allowable collision speed for collision with the workpiece
- *5 A reference value for correcting errors in reciprocal operation
- *6 Impact resistance: No malfunction occurred when the actuator was tested with a drop tester in both an axial direction and a perpendicular direction to the lead screw. (The test was performed with the actuator in the initial state.)
Vibration resistance: No malfunction occurred in a test ranging between 45 to 2000 Hz. The test was performed in both an axial direction and a perpendicular direction to the lead screw. (The test was performed with the actuator in the initial state.)
- *7 Each value is only to be used as a guide to select a motor of the appropriate capacity.

LEY100 Series

Motorless Type Size 100

Dimensions: In-line Motor

LEY100

* part dimensions indicate the dimensions when a male rod end is selected.

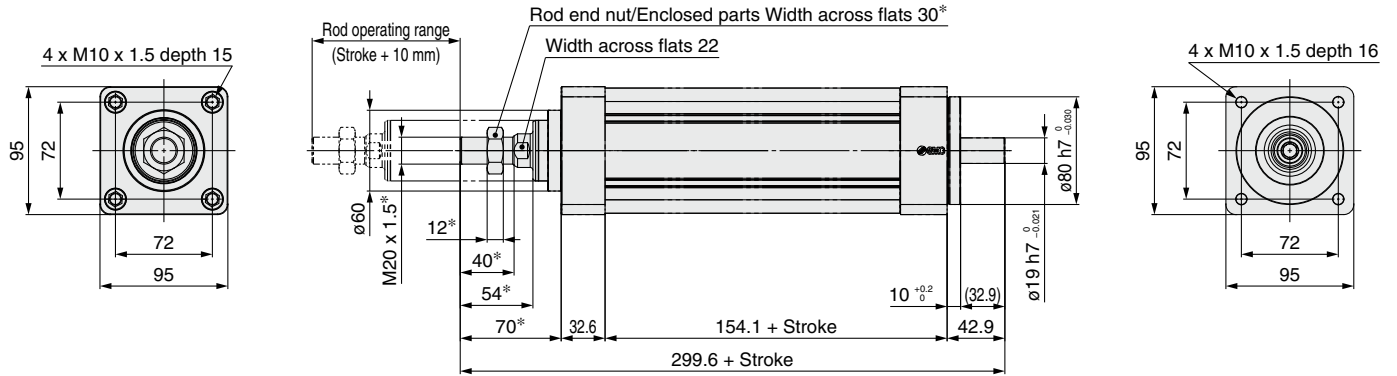

Rod end female thread: LEY100DNNB-□□□□

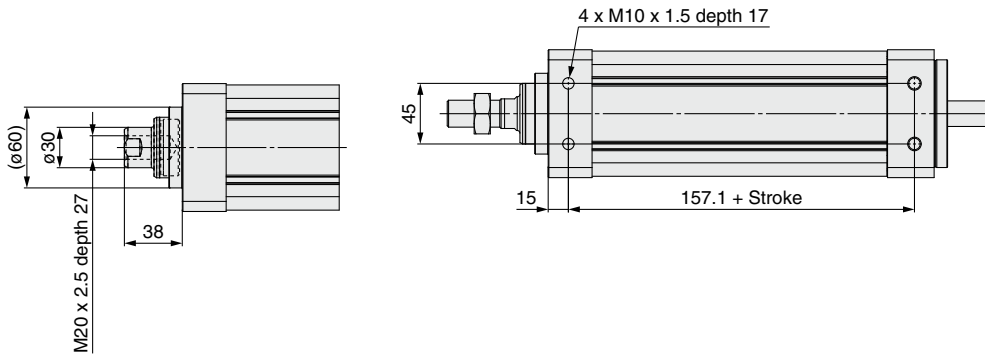

Rod flange shape: LEY100DNNB-□□□□F

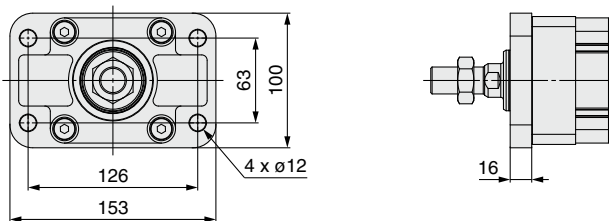

Foot: LEY100DNNB-□□□□L

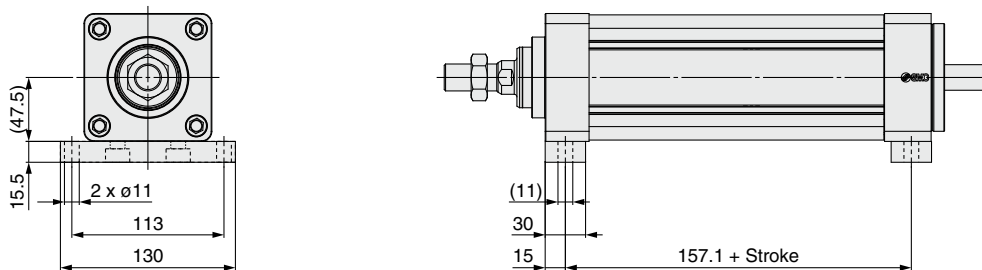

LEY100 Series Option

Motor Flange Assembly

Motor flange LEY - MF 100 D - NZ

1

1 Motor flange type

Symbol	Motor type	(Note)	A Motor adapter	B Motor flange	C Coupling (O.D. ø40)	C Coupling (O.D. ø55)	D Reducer
NZ	Mounting type Z	Mitsubishi and others	●	●	—	—	—
NZC	Mounting type Z + Coupling included	O.D. ø40	●	●	●	—	—
NG	Mounting type G	For reducers	●	●	—	—	—
NGC	Mounting type G + Coupling included	O.D. ø55	●	●	—	●	—
NGC3	Mounting type G + With reducer*1	Reduction ratio 1/3	●	●	—	●	●
NGC5	Mounting type G + With reducer*1	Reduction ratio 1/5	●	●	—	●	●
N	Without motor flange	Motor adapter only	●	—	—	—	—

*1 A coupling (O.D. ø55) is also included.

Compatible Motors

Manufacturer	Series	Type	NZC/ NGC3/ NGC5
Mitsubishi Electric Corporation	MELSERVO-J4	HG-KR	●
	MELSERVO-J5	HK-KT	●
YASKAWA Electric Corporation	Σ-V	SGMJV	●
	Σ-7	SGM7J	●
SANYO DENKI CO., LTD.	SANMOTION R	DXF	●
	SANMOTION R	R2	●
NIDEC SANKYO CORPORATION	S-FLAG	MX	●
KEYENCE CORPORATION	SV	SV-M/SV-B	●
FUJI ELECTRIC CO., LTD.	ALPHA5/ALPHA7	GYS/GYB/GYG	●
Delta Electronics, Inc.	ASDA-A2	ECMA	●

A Motor adapter

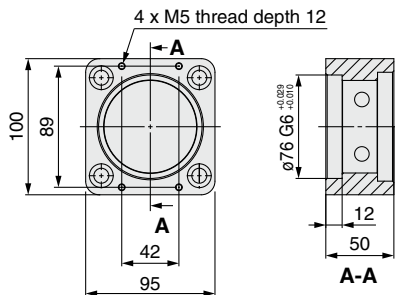

B Motor flange (Mounting type Z)

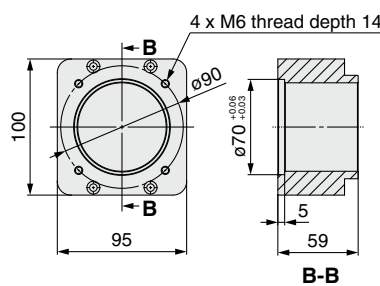

C Motor flange (Mounting type G)

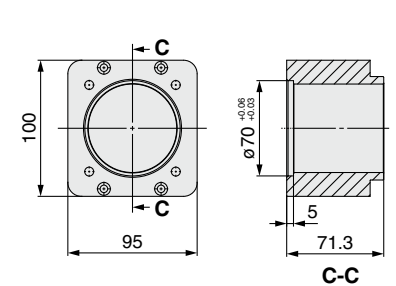

C Coupling

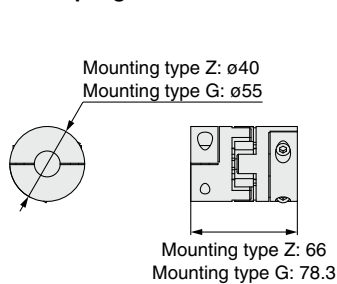

D Reducer (Reduction ratio 1:3/1:5)

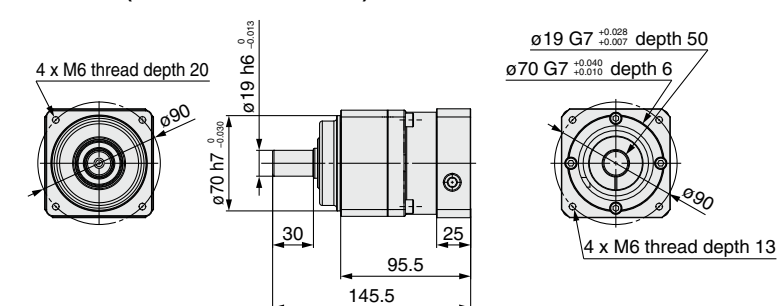

Mounting Bracket

LEY - L 100

1

1 Mounting bracket

Symbol	Mounting bracket
L	Foot
F	Flange

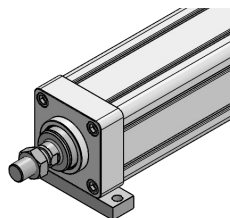

L: Foot

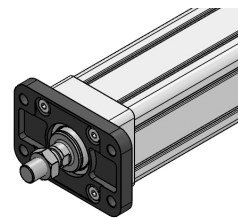

F: Flange



LEY100 Series Specific Product Precautions

Be sure to read this before handling the products.

Handling

Caution

Continuous use at max. force is prohibited.

When using the product at max. force, be sure to use the product within 15 s and with a duty ratio of 20% or less. (With motor)

Example of driving conditions with a duty ratio of 20%

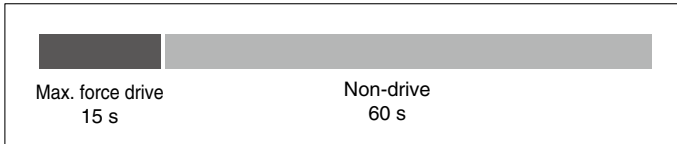

For the motorless type, be sure to check the specifications of the motor and driver to be used in combination before use. The force should be within the rated force when using continuously.

Motor Flange Assembly

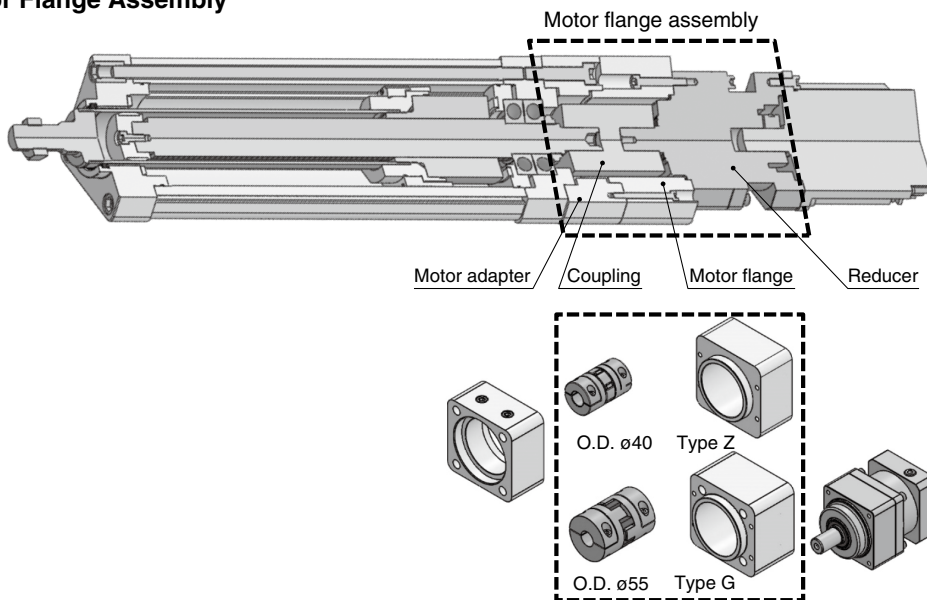

Products from other companies and self-produced products can be used instead.

Symbol	Motor adapter	Motor flange (Type)	Coupling (ø40)	Coupling (ø55)	Reducer (Reduction ratio)
NZ	●	● (Z)	—	—	—
NZC	●	● (Z)	●	—	—
NG	●	● (G)	—	—	—
NGC	●	● (G)	—	●	—
NGC3	●	● (G)	—	●	● (1/3)
NGC5	●	● (G)	—	●	● (1/5)
N	●	—	—	—	—

AC Servo Motor Motorless Type

Electric Actuator Rod Type



⚠ Safety Instructions Be sure to read the “Handling Precautions for SMC Products” (M-E03-3) and “Operation Manual” before use.