

# MODEL SK61722

## COMPRESSOR SERVICE KIT

For use on 607 and 617 Model Compressors with .22 Stroke

**⚠ WARNING:** Unplug the compressor before beginning disassembly.

**⚠ CAUTION:** Improper assembly or use of damaged parts may lead to premature failure. To avoid frequent repairs follow the recommended assembly procedures.

This kit includes the following parts:

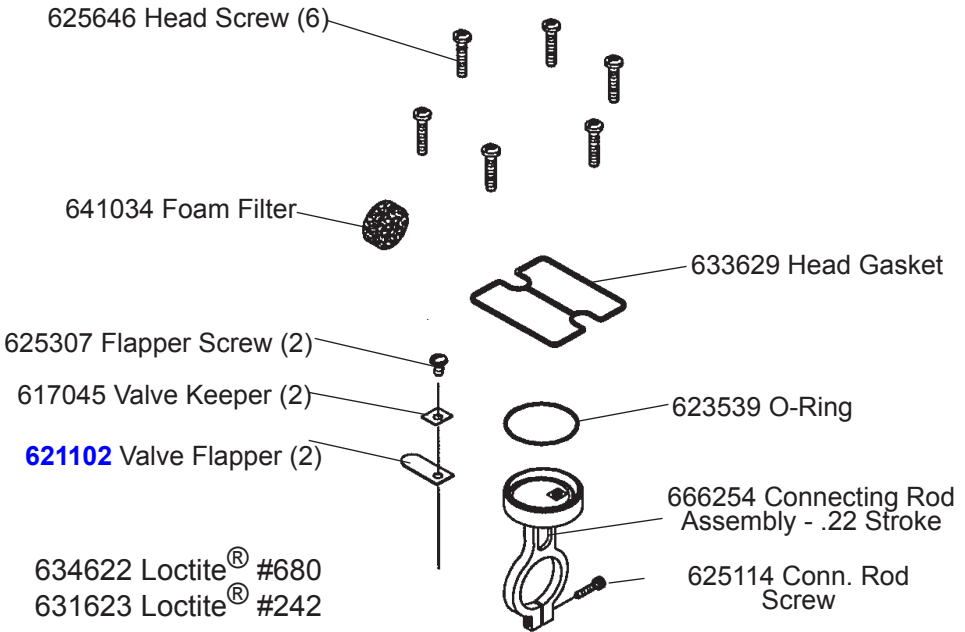

**NOTE:** Before you begin, read these instructions thoroughly and assemble the necessary tools. You will need:

- 1/8" Hex Socket attachment for torque wrench
- Torx T-20 attachment for torque wrench (for retainer screws)
- Torx T-25 attachment for torque wrench (for head screws).
- 5/32" allen wrench for for torque wrench (eccentric screw)
- Flat Screwdriver
- Clean Cloths

Part No.642673A 0307

USAThomas.com

(800) 799-4568 | 3810 Prospect Ave, Ste. A, Yorba Linda, CA 92886

## DISASSEMBLY

**STEP 1.** Clean loose dirt from the outside of the compressor.

**STEP 2.** Unscrew the 6 head screws (1-discard screws) and remove the compressor head (2).

**STEP 3.** Carefully remove the valve plate (4) from the bottom of the head. Remove the head gasket O-ring (3) and discard it. Clean head with a soft, clean cloth and set aside for re-assembly later in the repair process.

**STEP 4.** Turn the valve plate over. Remove the valve plate O-ring and discard it.

**STEP 5.** Remove the 4 screws (6) securing the plastic front cover (5), and pull cover off. Retain screws and cover for reassembly.

Figure 1

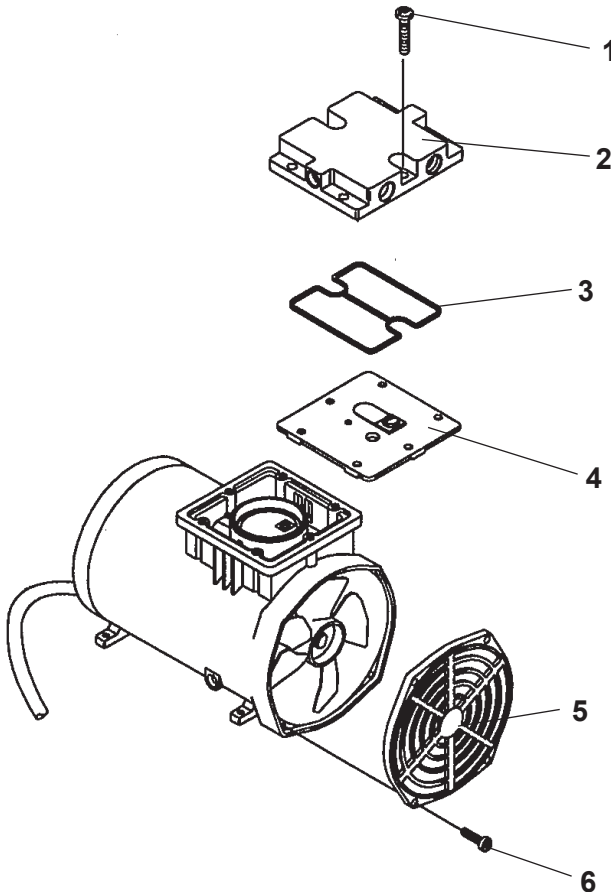

**STEP 6.** Remove the valve flapper screw (1), keeper (2) and valve flapper from the top of the valve plate and discard. Clean the top of the plate with a clean, soft cloth. Install the new valve flapper, keeper and screw centered over the port as shown. The valve keeper should be placed on top of the flapper so that the word "UP" is visible.

**NOTE:** Torque new flapper screw to 18 inch-pounds.

**STEP 7.** Remove the valve flapper screw (6), restraint (5) and valve flapper (4) from the bottom of the valve plate and discard them. Clean the bottom of the plate with a clean, soft cloth. Install the new flapper, restraint and screw centered over the port as shown. The valve keeper should be placed on top of the flapper so that the word "UP" is visible.

**NOTE:** Torque flapper screw to 18 inch-pounds. Set Valve Plate Assembly aside for re-assembly later in repair process.

**STEP 8.** Remove the fan by prying the fan hub with a screwdriver. (See Fig. #3).

Note position of fan for reassembly. (Hub facing in? Hub facing out?)

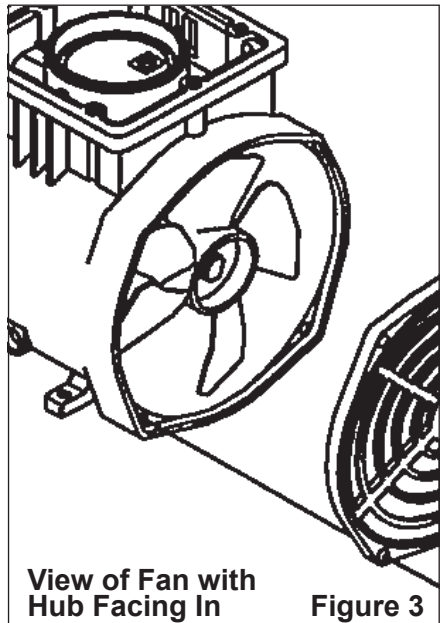
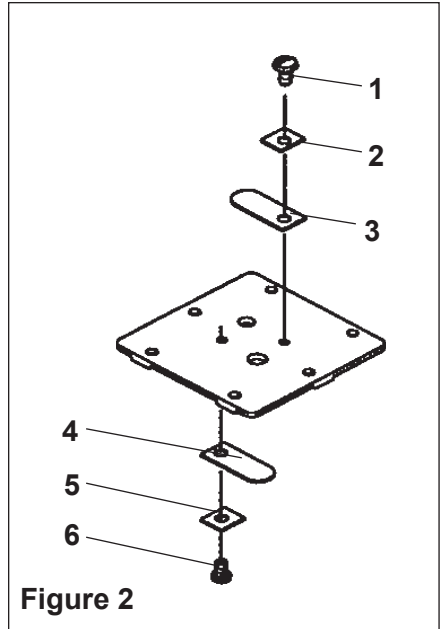

**STEP 9.** Insert a 1/8" hex wrench into the hole in the left side of the compressor housing (See Fig. #4). Loosen the set screw in the eccentric. Insert a 5/32" hex wrench into the right side of the housing and loosen the clamping screw at the base of the connecting rod .

**Figure 4**

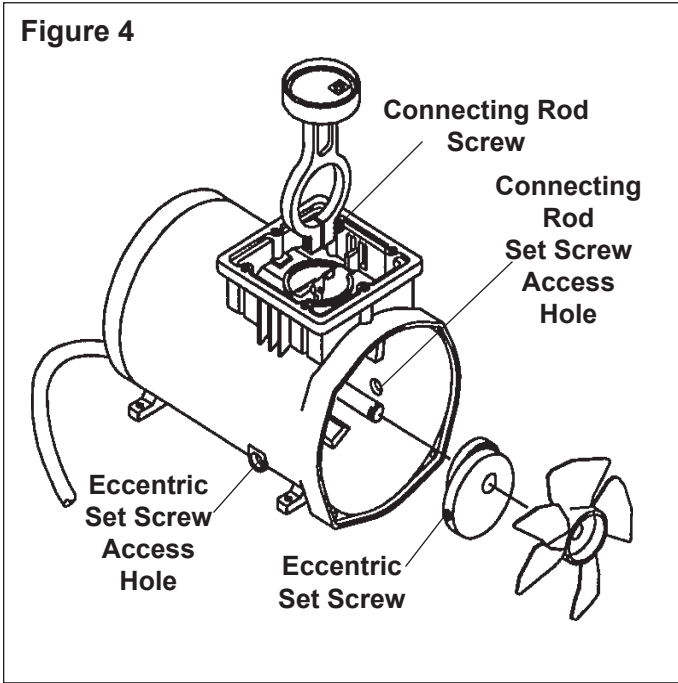

**NOTE:** It may be necessary to insert a flat tip screwdriver into the slot in the base of the connecting rod, and spread the base slightly, in order to free it from the bearing (See Fig. #5).

**STEP 10.** Slide the bearing off of the shaft, then pull the connecting rod out of the top of the housing (See Fig. #4).

**Figure 5**

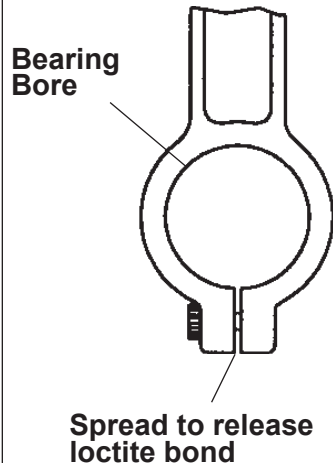

## REASSEMBLY

**STEP 1.** Clean the old adhesive from connecting rod bearing (mounted on the eccentric). Apply Loctite® #680 (supplied) to the bearing bore of the new connecting rod. (See Fig. #2). Apply Loctite® #242 (supplied) to the threads of the clamping screw, and turn the screw a few turns into the new rod. Do not tighten. Drop the new rod and sleeve assembly through the top of the compressor housing with the head of the rod clamping screw to the right (as viewed through the open end of the compressor housing). Slide the eccentric and bearing assembly onto the shaft and into the bearing bore of the connecting rod. (See Fig. #4)

**STEP 2.** Align the front face of the connecting rod with the front face of the bearing. This will result in a clearance of about .032 inch between the rod and the eccentric (See Fig. #6). Tighten the connecting rod screw to 15 in. - lbs. torque. **DO NOT OVERTIGHTEN**, or bearing damage/connecting rod breakage may result.

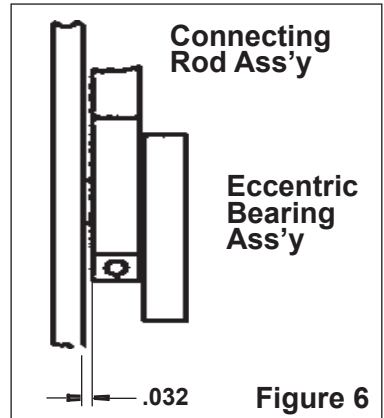

**STEP 3** Center rod and sleeve in pocket in the top of the unit.

**STEP 4.** Slide the sleeve down until it contacts the housing. The locator ribs should bear against the inside surface of the sleeve.

## **CHECK OPERATION**

**STEP 5.** Hold the sleeve down against the housing with one hand, and slowly rotate the eccentric with the other hand. As the piston travels up and down it will also rock from side to side. This is a feature of the WOB-L Piston. **If it rocks from front to rear, the connecting rod is misaligned on the eccentric.** If front to rear rocking is detected, loosen the connecting rod clamping screw and repeat Steps 6, 7, and 8. If the connecting rod cannot be properly aligned, contact the nearest service center.

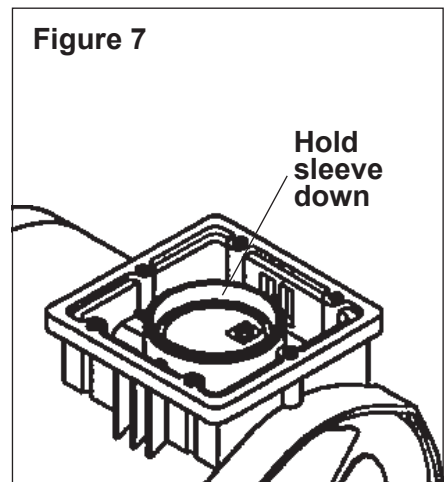

**STEP 6.** With the sleeve located and firmly seated on the housing, replace the valve plate as shown in Fig. #8. Make sure the top edge of the sleeve locates in the O-ring groove in the bottom of the valve plate.

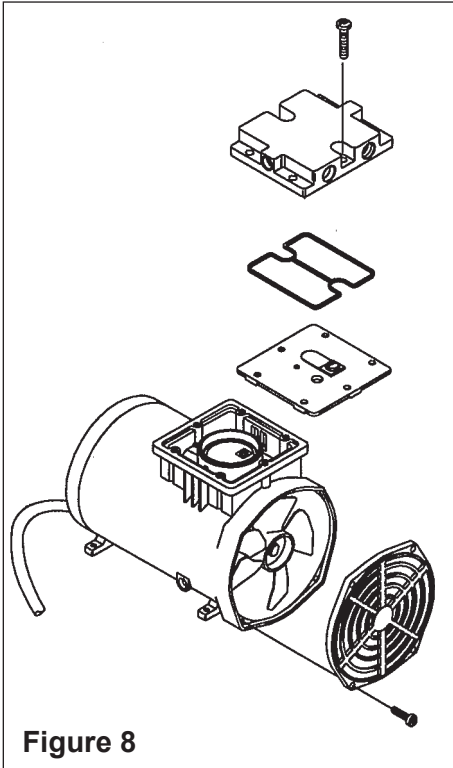

**⚠ CAUTION:** Make sure o-ring is not twisted when seated in groove.

**STEP 7.** Place the new head gasket into the groove inside the head, seating it firmly in the groove with your finger or blunt object.

**STEP 8.** Place the head on the top of the valve plate in the same orientation as it was when removed. Install the 6 head screws and tighten in a criss-cross pattern to 45 in-lbs.

**NOTE:** Some of these models are equipped with a carrying handle. The handle, if present, should extend over the motor to provide proper balance when the unit is carried.

**STEP 9.** Slide the fan onto the shaft in the same orientation that it was before it was removed.

## **⚠ Caution**

To avoid property damage or personal injury, always try rotating the fan by **HAND** prior to connecting the unit to the power source. Check for suction at the air inlet port by placing your finger over the port as you turn the fan. You should feel a slight suction with each rotation of the fan. If you don't feel suction, or if you feel or hear a thump as you turn the fan, **DO NOT CONNECT THE UNIT TO A POWER SOURCE;** review the assembly procedure for possible error.

**STEP 10.** Assemble the front cover.

**STEP 11.** Run unit at free flow for five minutes. Check that air exists at exhaust port.

**STEP 12.** Remove the filter cap from the filter body by prying it with a flat screwdriver. Remove the old foam filter and discard. Replace with the new filter and snap filter cap back into place.

