

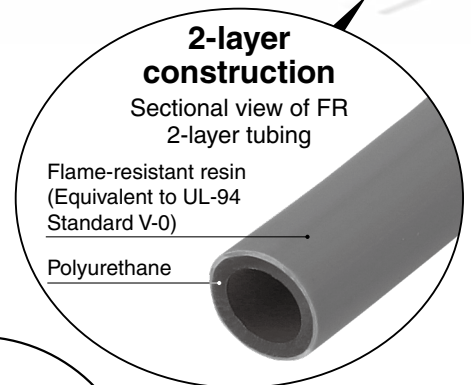

Flame Resistant (Equivalent to UL-94 Standard V-0) FR 2-Layer Soft Polyurethane Tubing

Peeling of the outer layer not required to connect fittings
Reduced labor time, Improved workability

- Improved flexibility (Compared with the TRBU)
- No inner tubing exposure when connecting fittings
- Lightweight and Compact
Weight: **57%** reduction,
Cross sectional area: **37%** reduction
(Compared with the TRBU0805)
- Suitable for air and water piping in environments where spot welding spatter may be a problem
- Increased flow rate due to I.D. expansion:
Max. 69% improvement
(Comparison between the TRBU1208 and the TRBU1210-X259)



Environment where welding spatter scatters

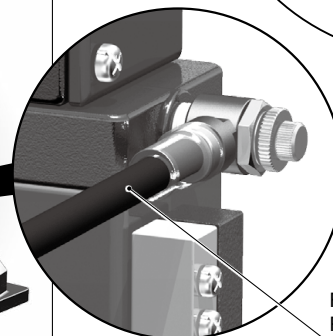
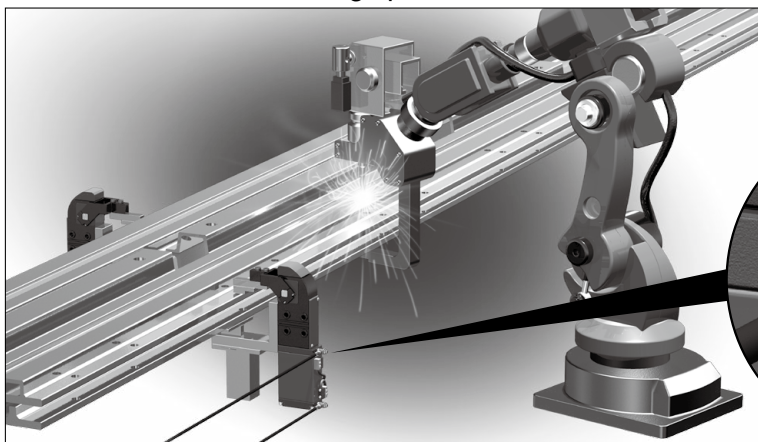

FR 2-Layer Soft Polyurethane Tubing

Series Comparison

		TRBU-X259	TRBU
Tubing model			
Tubing construction		2-layer (Outer layer peeling not required)	2-layer
Inner tubing	Material	Polyurethane	
Outer layer	Material	Flame-resistant resin	Flame-resistant polyolefin
	Flame resistant	Equivalent to V-0	Equivalent to V-0
Flexibility		◎	○
Spatter resistant		○	◎
Abrasion resistant		◎	○

◎: Excellent ○: Good

* Relative comparison based on SMC's testing conditions

TRBU-X259



TRBU-X259

Model*1

● — 100 m reel

		Tubing size (Metric size)							
Model		TRBU3220	TRBU0425	TRBU0604	TRBU0805	TRBU1065	TRBU1007	TRBU1285	TRBU1210
O.D. [mm]		3.2	4	6	8	10	10	12	12
I.D. [mm]		2	2.5	4	5	6.5	7	8.5	10
Color*2	Black (B)	○	●	●	●	●	○	●	○
	White (W)	○	○	●	●	●	○	●	○
	Red (R)	○	○	○	●	○	○	○	○
	Blue (BU)	○	○	●	●	●	○	○	○
	Yellow (Y)	○	○	●	○	○	○	●	○
	Green (G)	○	○	○	○	●	○	●	○

Specifications

Fluid		Air, Water							
Max. operating pressure [MPa]	20°C or less	0.8	0.8	0.8	0.8	0.8	0.7	0.7	0.35
	40°C	0.65	0.65	0.65	0.65	0.65	0.5	0.5	0.2
	60°C	0.5	0.5	0.5	0.5	0.5	0.35	0.35	0.14
	80°C	0.35	0.35	0.35	0.35	0.35	0.3	0.3	0.12
Applicable fittings		FR One-touch fittings KR-W2 series, Metal One-touch fittings KQB2 series, Insert fittings KF series							
Operating temperature		-20 to +80°C, Water: 0 to 60°C (No freezing)							
Material	Inner tubing	Polyurethane							
	Outer layer	Flame-resistant resin (Equivalent to UL-94 Standard V-0)							

*1 Products marked with "○" are available as a special order.

*2 The colors are opaque.

Max. Operating Pressure

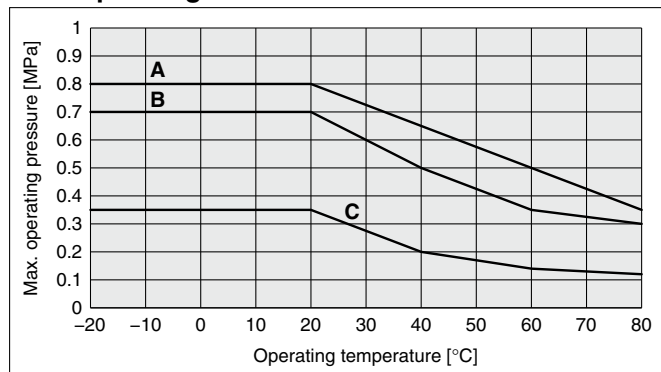

Group	Model	Max. operating pressure [MPa]			
		20°C or less	40°C	60°C	80°C
A	TRBU3220	0.8	0.65	0.5	0.35
	TRBU0425				
	TRBU0604				
	TRBU0805				
	TRBU1065				
B	TRBU1007	0.7	0.5	0.35	0.3
	TRBU1285				
C	TRBU1210	0.35	0.2	0.14	0.12

How to Order

TRBU0604 **B** - **100** - X259

Tubing model

Color

Length per roll

Symbol	Length
100	100 m reel

Symbol	Color	Symbol	Color
B	Black	BU	Blue
W	White	Y	Yellow
R	Red	G	Green

⚠ Precautions

Be sure to read this before handling the products. For safety instructions and fittings & tubing precautions, refer to the "Handling Precautions for SMC Products" and the "Operation Manual" on the SMC website.

⚠ Caution

- Applicable for general industrial water. Please consult with SMC if using any other kind of fluid. Also, the surge pressure must not exceed the maximum operating pressure. If the surge pressure exceeds the maximum operating pressure, it will result in damage to fittings and tubes.
- Abnormal temperature rises caused by adiabatic compression may result in the tube bursting.

⚠ Safety Instructions Be sure to read the "Handling Precautions for SMC Products" (M-E03-3) and "Operation Manual" before use.