

Air Presses

AP-42P

1/4 Ton Arbor Press

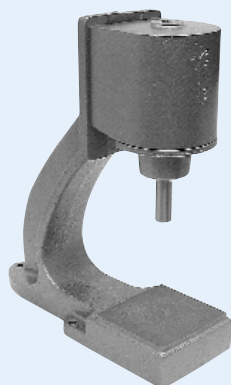

Versatile, light-duty press. Single-acting, spring return.

CP-400P

3/4 Ton Column Press

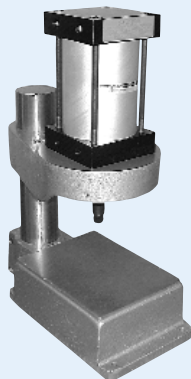

Column provides infinitely variable daylight settings and permits radial swing.

AP-400P

3/4 Ton Arbor Press

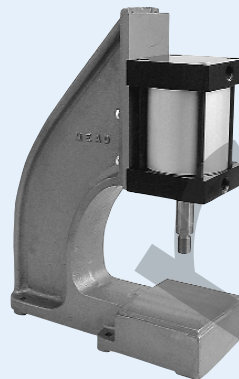

Heavy-duty cast iron frame is extremely rigid.

AP-600P

1 3/4 Ton Arbor Press



Welded steel plate frame. Cylinder mount and table are milled to provide precise rod alignment.

Reference

Control Valves

Cylinders

Specialty Valves

Production Devices

Accessories

Index

Air Presses Automate Tasks

Economical air powered presses reduce production costs by automating crimping, heat sealing, bending, forming, pressing, swaging, riveting and burnishing operations. Easy hook-up. Just attach to your shop air supply. No wiring, pumps, or motors needed.

Single-Acting Air Presses

Besides the AP-42P shown on this page, Mead offers two other single-acting alternatives. AP-122 combines a 4" bore single-acting cylinder (H-122) with the AP-400M press stand. AP-283 combines a 6" bore cylinder (#6030403) with the AP-600M press stand. A PL-600 cylinder-to-stand adapter plate is required for mounting this cylinder on the stand. Full dimensional drawings are given on the following page.

	1/4 Ton Arbor Press	3/4 Ton Column Press	3/4 Ton Arbor Press	1 3/4 Ton Arbor Press
Description				
Press Stand Only	AP-42M	CP-400M	AP-400M	AP-600M
Cylinder Mounted On Stand	AP-42P	CP-400P	AP-400P	AP-600P
Complete Press with Two Hand Controls (Not Piped)	-	CP-400C	AP-400C	AP-600C
Double Rod Option (DR)	NA	•	•	•
Non-Rotating Option (NR)	NA	•	•	•
Specifications				
Cylinder Bore (In.)	2 1/4	4	4	6
Thrust at 120 PSI (lbs.)	477	1508	1508	3393
Standard Stroke Length (In.)	2 (Spr. Ret)	4	2 1/2*	4*
SURFACE Table Width and Depth (In.)	3 x 3	6 7/8 x 8 3/4	5 x 5	8 x 8

Note: Standard column for Column Press is 14" long. Longer column (18" max.) is available on request.
* Additional stroke available to 4" on AP-400 and to 6" on AP-600. Consult factory.

Press Options

Rod Speed Reduction

To control the downward speed of double-acting presses, place a Mead Dyla-Trol valve (see page 59) in the bottom cylinder port so that incoming air flows freely and exhausting air is metered. Model MF1-25 is suitable for the control of all presses under most conditions.

Two Hand Control Unit

Models with a "C" suffix are supplied with a two hand anti-tiedown unit. Recessed trigger buttons, located in each end of the compact unit, require the press operator to use both hands concurrently to operate the press. Models CP-400C and AP-400C include the CSV-102, which has a built-in power valve. Model AP-600C includes the CSV-101 and a 1/2" power valve (C5-3). All air logic. No electrical wiring. See pages 60-61 for the two hand controls. See pages (20-21) for the power valve.

Double Rod Option (DR)

Double-acting press cylinders may be ordered with the piston rod extending from both ends. This minimizes rod deflection and make it possible to adjust stroke length. When a CP-400 is ordered with double rod, spacers are supplied to facilitate adjustment.

Press Speed Boost

Quick exhaust valves increase rod speed by allowing exhaust air to be dumped right at the cylinder instead of passing back through the directional valve. If speed is to be increased in both directions on double-acting presses, use one QEV in each port. Use model QEV-3 with 1/4 ton presses and model QEV-2B on 3/4 and 1 3/4 ton models. See page 67 for more information regarding QEVs.

AP-42

Shipping Weight: Stand Only = 9 lbs.
Stand/Cyl. = 10 lbs.

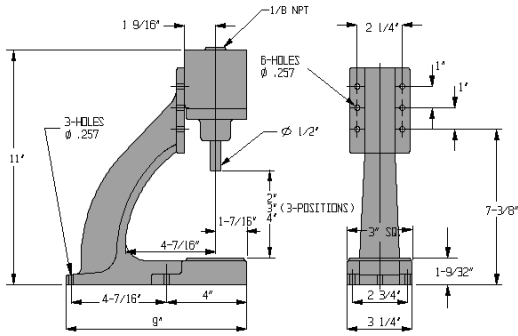

This press combines the AP-42M press stand with a Mead H-42 single-acting cylinder (2 1/4" bore, 2" stroke). Cylinder details are on page 51.

AP-122

Shipping Weight: Stand Only = 45 lbs.
Stand/Cyl. = 52 lbs.

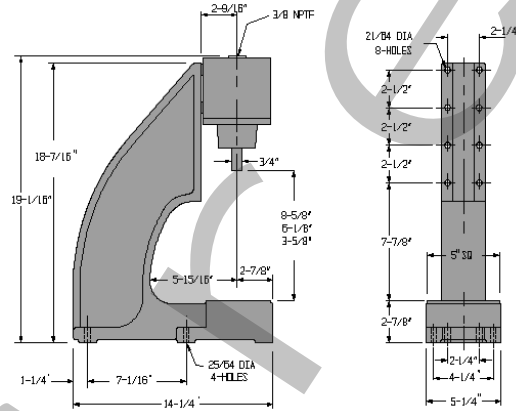

This press combines the AP-400M press stand with a Mead H-122 single-acting cylinder (4" bore, 2 5/8" stroke). Cylinder details are on page 51.

AP-400

Shipping Weight: Stand Only = 45 lbs.
Stand/Cyl. = 52 lbs.

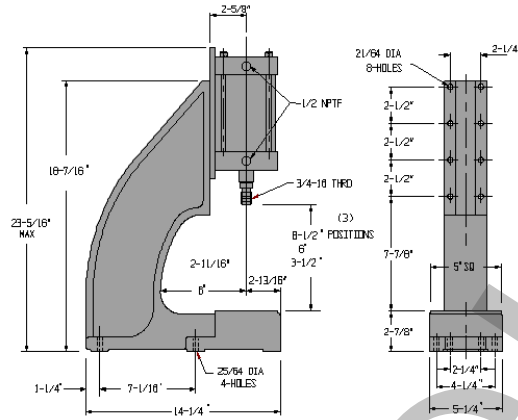

For non-standard double-acting service with strokes up to 4", use pages 34-35 to create a 4" bore cylinder for use with this stand. The PL-400 cylinder-to-stand adapter plate will be required.

CP-400

Shipping Weight: Stand Only = 90 lbs.
Stand/Cyl. = 105 lbs.

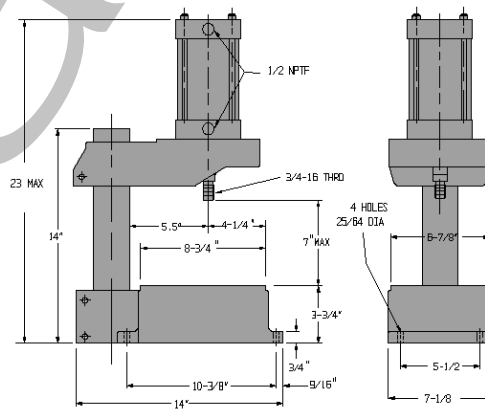

For other stroke lengths, heavy-duty or other options, use pgs. 34-35 to create any 4" bore cylinder for use with this press stand.

AP-283

Shipping Weight: Stand Only = 85 lbs.
Stand/Cyl. = 125 lbs.

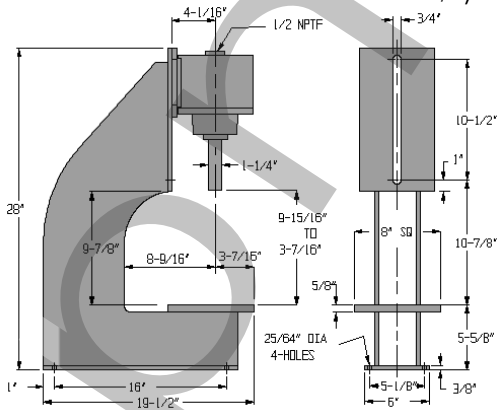

This press combines the AP-600M stand with Mead's #6040303 (H-283 with 3" longer ram, p. 51) single-acting cylinder (6" bore, 3" stroke). A PL-600 cylinder-to-stand adapter plate is required to mount this cylinder.

AP-600

Shipping Weight: Stand Only = 85 lbs.
Stand/Cyl. = 120 lbs.

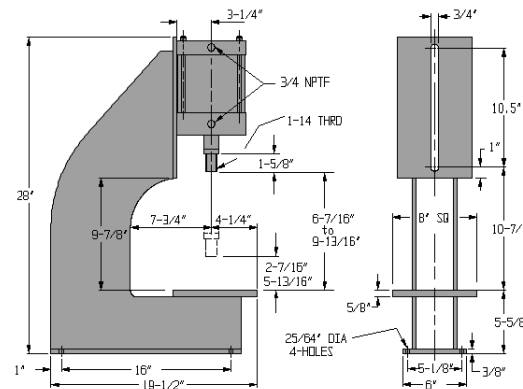

For non-standard double-acting service with strokes up to 6", use pages 34-35 to design a 6" bore cylinder for use with this stand.

Heavy Multi-Stage Press

Mead's latest press utilizes multiple stages to achieve a dramatically increased output force. A standard shop air input (110 PSI) can achieve a push output force of up to 6057 lbs. The standard model has two stages, but upon request Mead can provide more stages which means higher output force at an even lower input force.

Economical air powered presses reduce production costs by automating crimping, heat sealing, bending, forming, pressing, swaging, riveting and burnishing operations. Easy hook-up. Just attach to your shop air supply. No wiring, pumps, or motors needed

Operating Specifications

- Temperature Range:** -40°F to +250°F (to +400°F on request)
 - Lubrication:** For maximum cylinder life, non-detergent petroleum based oil is recommended. Non-lube seals available.
 - Filtration:** Standard 40 micron filter for maximum life.
 - Maximum Pressure:** 110psi
 - Maximum Output Force:** 6057lbs
 - Thrust Multiplier:** 55*
- *To determine thrust at other inlet pressure, multiply factor by desired pressure

Dimensions

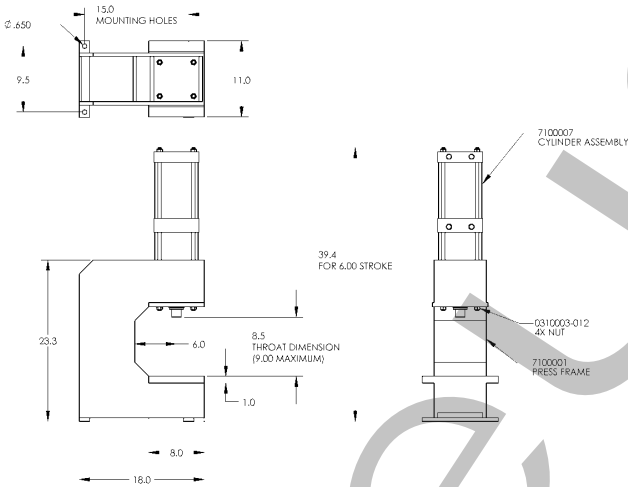

Note: For each inch of stroke overall height increases by 2"

Materials

- Rod Bearing:** Teflon-impregnated, hardcoated aluminum
- Heads:** Machined from solid aluminum bar; black anodized
- Tubes:** Aluminum hard anodized to 60 Rc (16 RMS finish)
- Piston:** Solid high alloy aluminum
- Piston Rod:** High tensile ground and polished hard chrome plated steel
- Piston and Rod Seals:** Wear compensating Buna N vee rings. Self-lubricating seals also available (see Option NL).
- Tube Seals:** Buna N o-rings
- Rod Wiper:** Dupont Teflon®
- Tie Rods:** High tensile steel torqued to allow for flexure.
- Stand:** Welded steel frame.

Press Options:

Two Hand Control Unit: Models with a "C" suffix are supplied with a two hand anti-tiedown unit. Recessed trigger buttons, located in each end of the compact unit, require the press operator to use both hands concurrently to operate the press. Model HP-600C includes the CSV-101 and a 1/2" power valve (C5-3). All air logic. No electrical wiring. See pages 60-61 for the two hand controls. See pages (20-21) for the power valve.

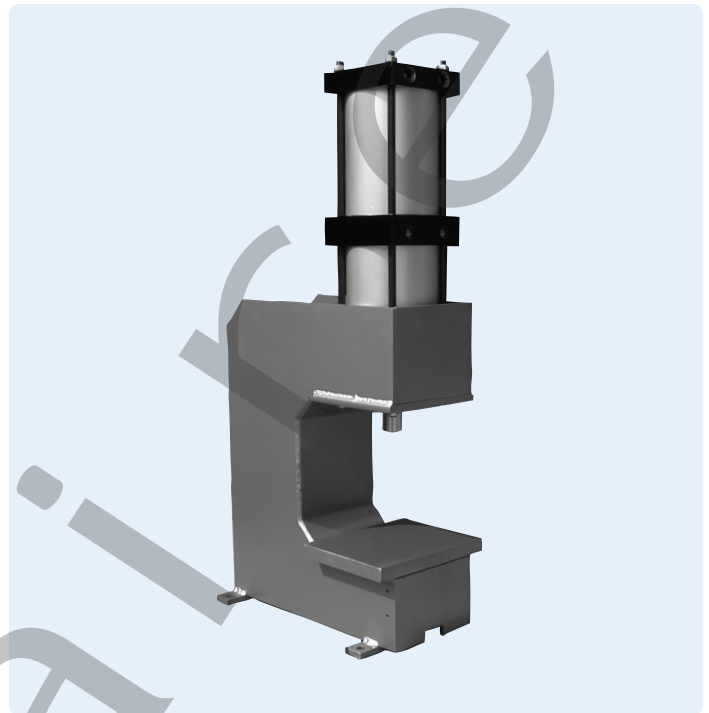

Ordering Information

Model #	Description
HP-600M	Press stand only.
HP-600P	Cylinder mounted on stand
HP-600C	Complete press with 2 hand controls (not piped).

Specify:

Throat dimension "T" Min=1/2" Max=9"
 Stroke dimension "S" Min=1/4" Max=9"

Sample Part

HP-600P G2 - T8.00 - S4.00



Contact Mead to consult for more than the standard two stages.

NOTE: Stroke cannot exceed throat.

Available Cylinder Options:

- CR = Cushion Rear
- IPR = Inter-Pilot Rear
- MP = Magnetic Piston

Consult Factory For Other Options

Rod Speed Reduction: To control the downward speed of double-acting presses, place a Mead Dyla-Trol valve (see page 59) in the bottom cylinder port so that incoming air flows freely and exhausting air is metered. Model MF1-50 is recommended.

Press Speed Boost: Quick exhaust valves increase rod speed by allowing exhaust air to be dumped right at the cylinder instead of passing back through the directional valve. See page 67.

Air Toggle Clamps

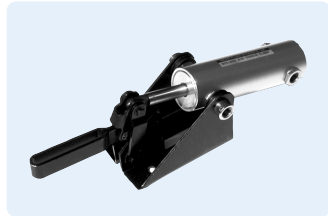

Air toggle clamps provide quick, automated clamping of work pieces in operations such as drilling, punching and forming. Air toggle clamps may also be plumbed for multiple installation...ideal for simultaneous operations.

A channel type steel holddown bar delivers up to 600 lbs. of holding force at 100 PSI. Once closed and locked, the bar stays positively locked for safer operation...even with a total loss of incoming air.

Air toggle clamps are completely assembled...just mount and attach air lines from a four-way valve (N2-PB shown, pg. 18-19). Opening and closing speeds may be adjusted with flow control valves (pg. 59 and 66).

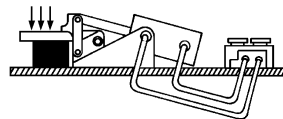

Model Number	Ports (NPSF)	Seals	Temp. Range
ATC-600	1/4"	Buna-N	40°F to +250°F
ATC-600-VI	1/4"	Viton	40°F to +400°F

Collet Fixtures



Use collet fixtures to evenly and firmly grip round bars during drilling, machining, positioning, or assembling tasks...without marring the surface of the bars.

Workpieces may pass through the fixture. Model PCF accepts standard 3C collets. Model LS-1 accepts standard 5C collets. A collet wrench is supplied to simplify collet installation and removal. Mead does not offer collets.

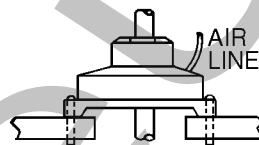

Air Impact Hammer



(Includes all controls)

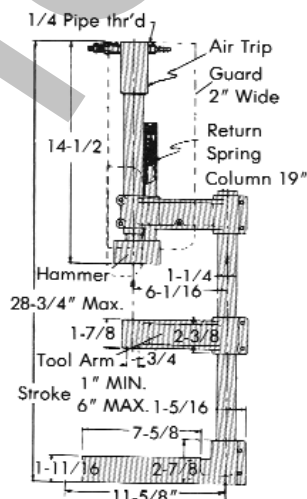

Note: Width is 4 11/16"
Pressure Range: 25-175 PSI

Accessories

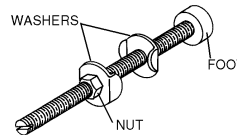

An optional adjustable spindle assembly is ideal for clamping work pieces that vary in height or may be damaged by the steel holddown bar.

Model Number	Description
9300023	Spindle Assembly, Neoprene Foot, Nuts & Washers
9300022	Spindle Assembly, Steel Swivel Foot, Nuts & Washers

Dimensions & Specifications

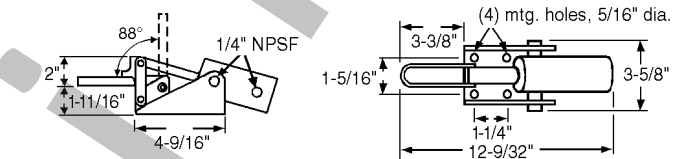

General Specifications			
Pressure Range:	0 to 100 PSI Air	Cylinder Bore:	1 1/2"
Holddown Bar:	Cold Rolled Steel	Cylinder Stroke:	2 1/4"

Double-acting collet fixtures must be actuated by a four-way valve. Model PCF will prevent a round, smooth bar from turning at up to 10 ft. lbs. of applied torque; model LS-1 at up to 40 ft. lbs. at 100 PSI.

Dimensions & Specifications



Model No.	Applied Holding Pressure @ 100 PSI; Max. 120 PSI	Collet Type	Round Stock Capacity	A (Sq.)	B (Sq.)	C	D (4)
PCF	3,400 lbs.	3C	1/2"	4 7/8"	4"	3 7/16"	.257"
LS-1	7,100 lbs.	5C	1"	7"	5 7/16"	4 9/16"	.390"

AH-65 delivers a consistent, uniform blow. It is designed to accelerate, then strike a tool which may be guided by the supplied tool arm. A spring returns the hammer to the start position after the work is completed. The head must be free with no fixturing or tooling attached directly to it.

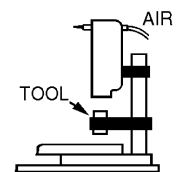

The air hammer's impact force may be adjusted from a few ounces to 4,500 lbs. by raising or lowering the air hammer, adjusting the air trip needle valve, or adjusting the air pressure. The air trip mechanism releases the hammer head when the air in the chamber reaches a pre-set level. The hammer head accelerates to the end of its stroke, with a longer stroke (6" maximum) creating greater velocity and greater impact.

All Controls Included



AH-65 is supplied with a CSV-102 two-hand control unit. The CSV-102 requires the operator to use two hands concurrently and also provides the power valve to run the hammer. See pg. 60.