

Fittings

Pneufit push-in elbow banjo flow controls

1/8" to 1/2", 4 to 12 mm O/D tube

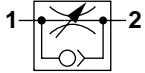

High maximum flow, progressive flow gain, and positive tube grip
Silicone free 'O'-ring seals
Non-PTFE based thread sealant on all BSP taper threads (VAO, VBO, TAO)

Easy tube insertion for rapid assembly

For simple and quick assembly of pneumatic circuits

Wide range available

Reliable and corrosion resistant

Technical data

Fluid:

Compressed air

Operating pressure:

5 to 150 psig (.3 to 10 bar) unless otherwise stated (dependent upon tubing specification).

Temperature range:

0° to 175°F (-20° to 80°C).

Materials

Body: Nickel plated brass, glass filled nylon, or PBT

Collet: Nickel plated brass

Grabring: stainless steel

'O'-ring: Silicone free nitrile rubber

Sealing washer (parallel threads):

Nitrile 'O'-ring

Thread sealant: non-PTFE

Tube types

Nylon 11 or 12, polyurethane (95 durometer and 85 durometer on C0 and C2 models)

VAO and TAO Series

A	B	O.D. NPT or UNF Part		C	D	E	F	G	H	J	K	L
Tube	Thread	Number									A/F	Adj
5/32"	10-32 UNF	12 VAO 0210		0.37	1.04	0.16	0.28	0.38	1.51	0.45	-	0.12
5/32"	1/8	12 VAO 0218		0.45	0.87	0.31	0.35	0.63	2.09	0.89	9/16"	0.12
1/4"	1/8	12 VAO 0418		0.51	0.91	0.31	0.35	0.63	2.09	0.89	9/16"	0.12
1/4"	1/4	12 VAO 0428		0.53	1.00	0.39	0.43	0.79	2.64	1.16	11/16"	0.24
3/8"	1/4	12 VAO 0628		0.77	1.24	0.39	0.43	0.79	2.64	1.16	11/16"	0.24
3/8"	3/8	12 VAO 0638		0.77	1.28	0.47	0.51	0.87	3.07	1.30	3/4"	0.24
1/2"	1/2"	12 VAO 0748		0.91	1.50	0.63	0.71	1.06	3.66	1.65	7/8"	0.28

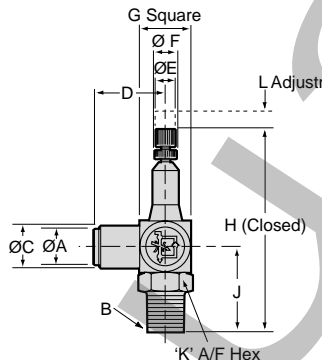

A	B	O.D. ISO R Part		C	D	E	F	G	H	J	K	L
Tube	Thread	Number									A/F	Adj
4	1/8	10 TAO 0418		11.5	22.0	8.0	9.0	16	53	22.5	14	3
6	1/8	10 TAO 0618		13.0	23.0	8.0	9.0	16	53	22.5	14	3
6	1/4	10 TAO 0628		13.5	25.5	10.0	11.0	20	67	29.5	17	6
8	1/4	10 TAO 0828		15.5	27.0	10.0	11.0	20	67	29.5	17	6
8	3/8	10 TAO 0838		15.5	28.0	12.0	13.0	22	78	33.0	19	6
10	1/4	10 TAO 1028		19.5	31.5	10.0	11.0	20	67	29.5	17	6
10	3/8	10 TAO 1038		19.5	32.5	12.0	13.0	22	78	33.0	19	6

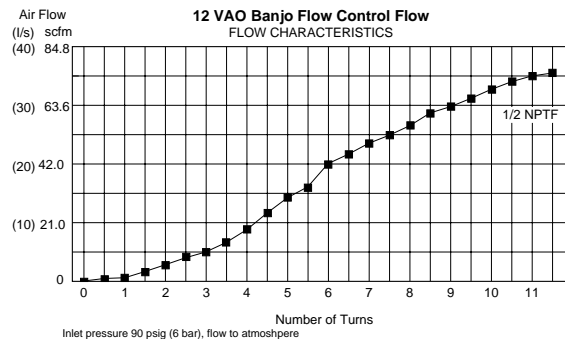
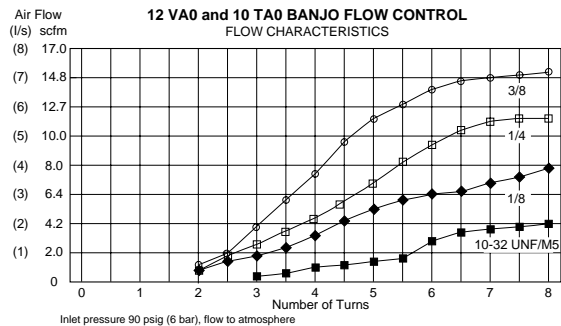

Pneufit push-in elbow banjo flow controls

Ø 4 ... 12 mm O/D tube

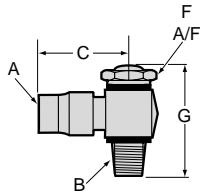

VBO Series

A	B	Part Number	C	F	G
NPT Female	NPT Male				
1/8	1/8	12 VBO 1818	0.83	9/16"	1.57
1/4	1/4	12 VBO 2828	1.14	3/4"	1.83
3/8	3/8	12 VBO 3838	1.24	7/8"	2.22
1/2	1/2	12 VBO 4848	1.53	1 1/16"	2.55

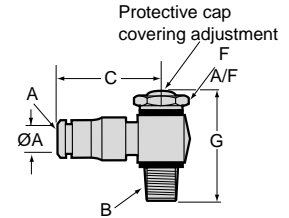

VBO Series

A	B	Part Number	C	F	G
O.D. Tube	NPT or UNF Thread				
5/32"	10-32 UNF	12 VBO 0210	0.74	-	1.06
5/32"	1/8	12 VBO 0218	0.88	9/16"	1.57
1/4"	1/8	12 VBO 0418	0.91	9/16"	1.57
1/4"	1/4	12 VBO 0428	0.99	3/4"	1.83
3/8"	1/4	12 VBO 0628	1.23	3/4"	1.83
3/8"	3/8	12 VBO 0638	1.29	7/8"	2.22
1/2"	3/8	12 VBO 0738	1.46	7/8"	2.22
1/2"	1/2	12 VBO 0748	1.56	1 1/16"	2.55

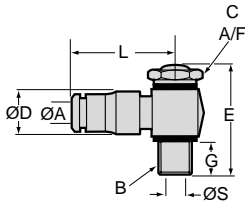

K51 Series

A	B	Part Number	C	D	E	G	L	S
O.D. Tube	ISO G or Metric Thread							
4	M5 X .8	10 K51 0405	8	9.5	26.5	4.0	18.7	2.5
4	1/8	10 K51 0418	14	11.0	34.0	6.5	20.6	5.0
5	M5 X .8	10 K51 0505	8	11.0	26.5	4.0	20.2	2.5
5	1/8	10 K51 0518	14	11.5	34.0	6.5	21.7	5.0
6	M5 X .8	10 K51 0605	8	12.5	26.5	4.0	22.2	2.5
6	1/8	10 K51 0618	14	12.5	34.0	6.5	23.7	5.0
6	1/4	10 K51 0628	17	13.0	36.5	7.0	24.2	8.5
8	1/8	10 K51 0818	14	13.5	34.0	6.0	23.7	-
8	1/4	10 K51 0828	17	14.0	36.5	7.0	24.7	8.5
8	3/8	10 K51 0838	22	16.5	51.5	10.0	26.7	10.0
10	3/8	10 K51 1038	22	17.0	51.5	10.0	31.2	10.0
12	1/2	10 K51 1248	27	17.5	57.5	10.0	38.2	-

12 VBO and 10 K51 BANJO FLOW CONTROL
FLOW CHARACTERISTICS

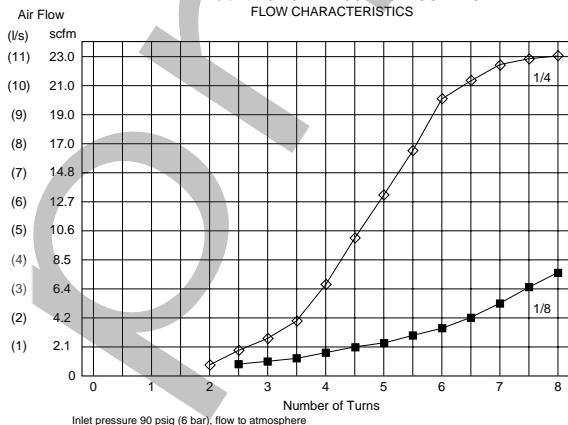

12 VBO and 10 K51 BANJO FLOW CONTROL
FLOW CHARACTERISTICS

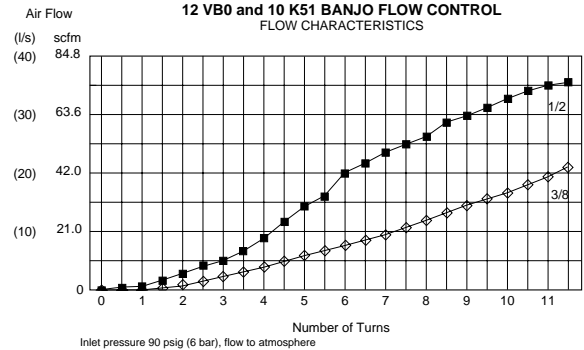

Fittings

Pneufit C Composite

Inch and Metric flow controls

Releasable stainless-steel grab-ring to grip nylon or polyurethane tube (85 or 95 durometer).

Nickel plated brass components provide corrosion and contamination resistance and an extended life.

Pre applied thread sealant on all taper threads and recessed captive O-ring on parallel threads provides optimum rapid sealing.

Immediate quality sealing using silicone free U-packing.

Technical data

Operating pressure

750mm Hg vacuum, up to 10 bar

Temperature

32°F to 140°F (0 to 60°C)

Medium

Compressed air

Materials

Body: PBT

Seals: NBR (silicone free) u-packing and O-rings

Threaded bodies: nickel plated brass

Release sleeve and backing ring: POM

Grab-ring: stainless steel

Collar: nickel plated brass

Thread sealant: threebond 2350B

Tube sizes

Inch: 5/32", 3/16", 1/4", 5/16", 3/8, 1/2"

Metric: 4, 6, 8, 10, 12, 16mm

Thread sizes

Inch: 10-32 UNF, 1/8", 1/4", 3/8 and 1/2" NPT and ISO R

Metric: M5, M6, 1/8", 1/4", 3/8" and 1/2", ISO G and ISO Rc

Tube types

Nylon 11 or 12

Polyurethane 85, 95 or 98 durometer

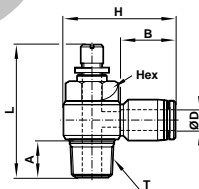
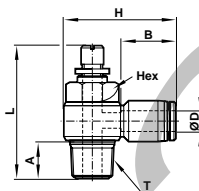

C2VA0 Inch

Banjo Flow Control

(Regulating out)

ØD	T	L		H	B	A	Hex	Part number
		min	max					
1/8	UNF 10/32	1.07	1.19	0.85	0.44	0.14	0.31	C2VA00110
5/32	UNF 10/32	1.07	1.19	0.99	0.64	0.14	0.31	C2VA00210
3/16	UNF 10/32	1.07	1.19	1.05	0.66	0.14	0.31	C2VA00310
1/4	UNF 10/32	1.07	1.19	1.13	0.69	0.14	0.31	C2VA00410
5/32	NPT 1/8	1.37	1.58	1.2	0.64	0.31	0.43	C2VA00218
3/16	NPT 1/8	1.37	1.58	1.24	0.66	0.31	0.43	C2VA00318
1/4	NPT 1/8	1.37	1.58	1.26	0.69	0.31	0.43	C2VA00418
5/16	NPT 1/8	1.37	1.58	1.3	0.74	0.31	0.43	C2VA00518
5/32	NPT 1/4	1.57	1.8	1.36	0.64	0.39	0.59	C2VA00228
3/16	NPT 1/4	1.57	1.8	1.39	0.66	0.39	0.59	C2VA00328
1/4	NPT 1/4	1.57	1.8	1.41	0.69	0.39	0.59	C2VA00428
5/16	NPT 1/4	1.57	1.8	1.45	0.74	0.39	0.59	C2VA00528
3/8	NPT 1/4	1.57	1.8	1.48	0.8	0.39	0.59	C2VA00628
1/4	NPT 3/8	1.84	2.17	1.56	0.69	0.43	0.75	C2VA00438
5/16	NPT 3/8	1.84	2.17	1.58	0.74	0.43	0.75	C2VA00538
3/8	NPT 3/8	1.84	2.17	1.66	0.8	0.43	0.75	C2VA00638
1/2	NPT 3/8	1.84	2.17	1.78	0.87	0.43	0.75	C2VA00738
5/16	NPT 1/2	2.09	2.37	1.8	0.74	0.55	0.94	C2VA00548
3/8	NPT 1/2	2.09	2.37	1.86	0.8	0.55	0.94	C2VA00648
1/2	NPT 1/2	2.09	2.37	1.99	0.87	0.55	0.94	C2VA00748

C2WA0

Banjo Flow Control (inch)

(Regulating in)

ØD	T	L		H	B	A	Hex	Part number
		min	max					
1/8	UNF 10/32	1.07	1.19	0.85	0.44	0.14	0.31	C2WA00110
5/32	UNF 10/32	1.07	1.19	0.99	0.64	0.14	0.31	C2WA00210
3/16	UNF 10/32	1.07	1.19	1.03	0.66	0.14	0.31	C2WA00310
1/4	UNF 10/32	1.07	1.19	1.13	0.69	0.14	0.31	C2WA00410
5/32	NPT 1/8	1.37	1.58	1.2	0.64	0.31	0.43	C2WA00218
3/16	NPT 1/8	1.37	1.58	1.24	0.66	0.31	0.43	C2WA00318
1/4	NPT 1/8	1.37	1.58	1.26	0.69	0.31	0.43	C2WA00418
5/16	NPT 1/8	1.37	1.58	1.3	0.74	0.31	0.43	C2WA00518
5/32	NPT 1/4	1.57	1.8	1.36	0.64	0.39	0.59	C2WA00228
3/16	NPT 1/4	1.57	1.8	1.39	0.66	0.39	0.59	C2WA00328
1/4	NPT 1/4	1.57	1.8	1.39	0.66	0.39	0.59	C2WA00428
5/16	NPT 1/4	1.57	1.8	1.45	0.74	0.39	0.59	C2WA00528
3/8	NPT 1/4	1.57	1.8	1.48	0.8	0.39	0.59	C2WA00628
1/4	NPT 3/8	1.84	2.17	1.56	0.69	0.43	0.75	C2WA00438
5/16	NPT 3/8	1.84	2.17	1.58	0.74	0.43	0.75	C2WA00538
3/8	NPT 3/8	1.84	2.17	1.66	0.8	0.43	0.75	C2WA00638
1/2	NPT 3/8	1.84	2.17	1.78	0.87	0.43	0.75	C2WA00738
5/16	NPT 1/2	2.09	2.37	1.8	0.74	0.55	0.94	C2WA00548
3/8	NPT 1/2	2.09	2.37	1.86	0.8	0.55	0.94	C2WA00648
1/2	NPT 1/2	2.09	2.37	1.99	0.87	0.55	0.94	C2WA00748

Pneufit C Composite

Inch and Metric flow controls

COK51

Banjo Flow Control (mm)

(out)

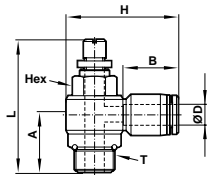

ØD	T	L		H	B	A	Hex	Part number
		min	max					
3.0	M5*0.8p	27.2	30.2	21.4	11.1	3.6	8.0	COK510305
4.0	M5*0.8p	27.2	30.2	25.1	16.3	10.0	15.0	COK510405
4.0	G 1/8	34.9	40.1	30.5	16.3	6.0	8.0	COK510418
4.0	G 1/4	40	45.7	34.5	16.3	8.0	12.0	COK510428
6.0	M5*0.8p	27.2	30.2	27.8	17.6	3.6	8.0	COK510605
6.0	G 1/8	34.9	40.1	31.2	17.6	6.0	8.0	COK510618
6.0	G 1/4	40	45.7	35	17.6	8.0	12.0	COK510628
6.0	G 3/8	46.7	55	38.7	17.6	8.0	14.0	COK510638
8.0	G 1/8	34.9	40.1	33	18.7	6.0	8.0	COK510818
8.0	G 1/4	40	45.7	36.8	18.7	8.0	12.0	COK510828
8.0	G 3/8	46.7	55	40.1	18.7	8.0	14.0	COK510838
8.0	G 1/2	53	60.2	45.8	18.7	9.0	19.0	COK510848
10	G 1/4	40	45.7	38.8	19.6	8.0	12.0	COK511028
10	G 3/8	46.7	55	42.2	19.6	8.0	14.0	COK511038
10	G 1/2	53	60.2	47.5	19.6	9.0	19.0	COK511048
12	G 1/4	40	45.7	40.8	21.9	8.0	12.0	COK511228
12	G 3/8	46.7	55	45.9	21.9	8.0	14.0	COK511238
12	G 1/2	53	60.2	50.1	21.9	9.0	19.0	COK511248

COTA0

Banjo Flow Control (mm)

(out)

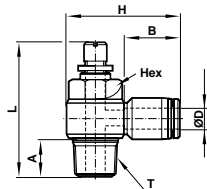

ØD	T	L		H	B	A	Hex	Part number
		min	max					
4.0	R 1/8	34.9	40.1	30.5	16.3	8.0	11.0	COTA00418
4.0	R 1/4	40.0	45.7	34.5	16.3	10.0	15.0	COTA00428
6.0	R 1/8	34.9	40.1	31.2	17.6	8.0	11.0	COTA00618
6.0	R 1/4	40.0	45.7	35.0	17.6	10.0	15.0	COTA00628
6.0	R 3/8	46.7	55.0	38.7	17.6	11.0	19.0	COTA00638
8.0	R 1/8	34.9	40.1	33.0	18.7	8.0	11.0	COTA00818
8.0	R 1/4	40.0	45.7	36.8	18.7	10.0	15.0	COTA00828
8.0	R 3/8	46.7	55.0	40.1	18.7	11.0	19.0	COTA00838
8.0	R 1/2	53.0	60.2	45.8	18.7	14.0	24.0	COTA00848
10.0	R 1/4	40.0	45.7	38.8	19.6	10.0	15.0	COTA01028
10.0	R 3/8	46.7	55.0	42.2	19.6	11.0	19.0	COTA01038
10.0	R 1/2	53.0	60.2	47.5	19.6	14.0	24.0	COTA01048
12.0	R 1/4	40.0	45.7	40.8	21.9	10.0	15.0	COTA01228
12.0	R 3/8	46.7	55.0	45.9	21.9	11.0	19.0	COTA01238
12.0	R 1/2	53.0	60.2	50.1	21.9	14.0	24.0	COTA01248

COSA0

Banjo Flow Control (mm)

(in)

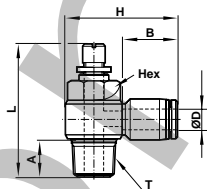

ØD	T	L		H	B	A	Hex	Part number
		min	max					
4.0	R 1/8	34.9	40.1	30.5	16.3	8.0	11.0	COSA00418
4.0	R 1/4	40.0	45.7	34.5	16.3	10.0	15.0	COSA00428
6.0	R 1/8	34.9	40.1	31.2	17.6	8.0	11.0	COSA00618
6.0	R 1/4	40.0	45.7	35.0	17.6	10.0	15.0	COSA00628
6.0	R 3/8	46.7	55.0	38.7	17.6	11.0	19.0	COSA00638
8.0	R 1/8	34.9	40.1	33.0	18.7	8.0	11.0	COSA00818
8.0	R 1/4	40.0	45.7	36.8	18.7	10.0	15.0	COSA00828
8.0	R 3/8	46.7	55.0	40.1	18.7	11.0	19.0	COSA00838
8.0	R 1/2	53.0	60.2	45.8	18.7	14.0	24.0	COSA00848
10.0	R 1/4	40.0	45.7	38.8	19.6	10.0	15.0	COSA01028
10.0	R 3/8	46.7	55.0	42.2	19.6	11.0	19.0	COSA01038
10.0	R 1/2	53.0	60.2	47.5	19.6	14.0	24.0	COSA01048
12.0	R 1/4	40.0	45.7	40.8	21.9	10.0	15.0	COSA01228
12.0	R 3/8	46.7	55.0	45.9	21.9	11.0	19.0	COSA01238
12.0	R 1/2	53.0	60.2	50.1	21.9	14.0	24.0	COSA01248

Fittings

Pneufit C Composite

Inch and Metric flow controls

Speed Controllers Flowrate for C2VA0, C2WA0, C0K51, C0L51, C0TA0, and C0SA0 Banjo Types

1/8, 5/32, 1/4" to
10/32 UNF, 3, 4, 6
mm, and M5

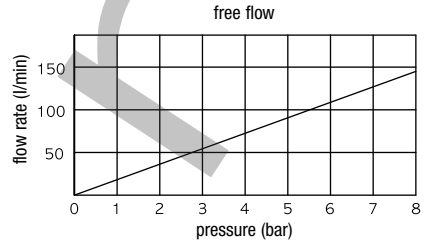
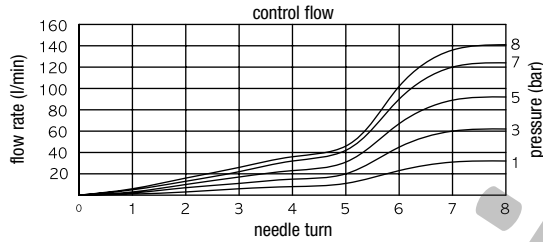

5/32, 1/4, 5/16 to
1/8 NPT, 4, 6, 8
mm, and 1/8"

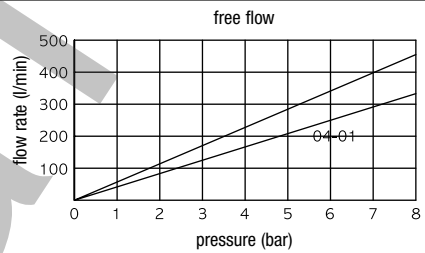
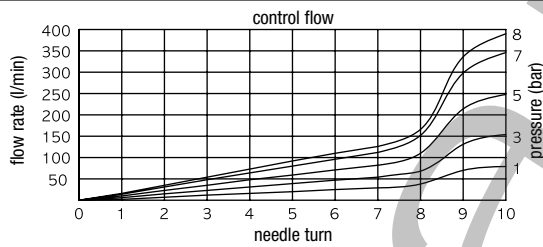

5/32, 1/4, 5/16,
3/8, 1/2 to 1/4
NPT, 4, 6, 8, 10, 12
mm, and 1/4"

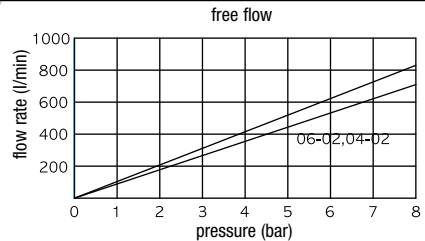
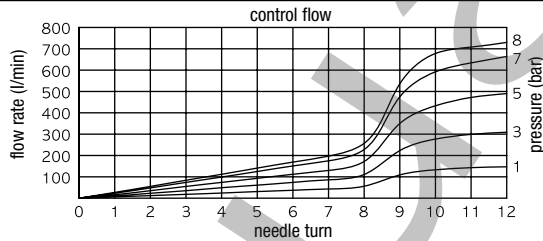

1/4, 5/16, 3/8, 1/2
to 3/8 NPT, 6, 8,
10, 12 mm, and
3/8"

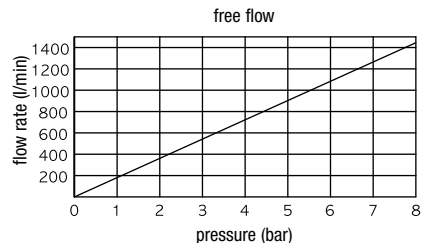
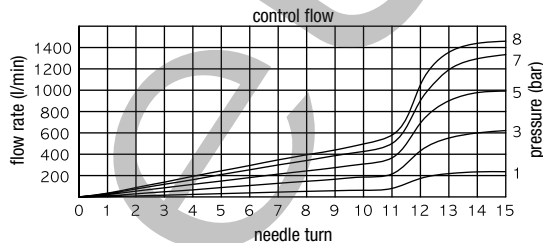

5/16, 3/8, 1/2 to 1/2
NPT, 8, 10, 12 mm,
and 1/2"

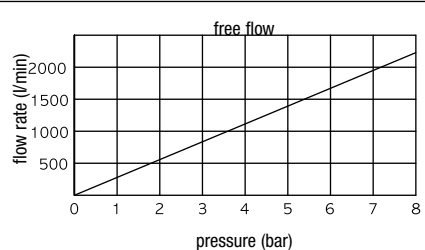
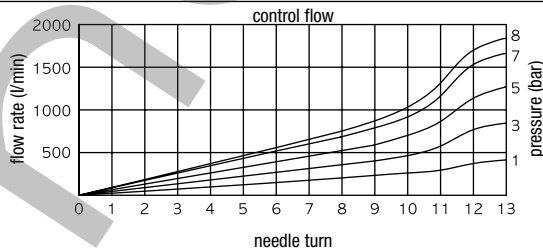

T1000 Series

Block form flow controls

Uni-directional

M5, 1/8" to 1/2" NPT or ISO G

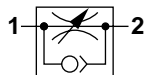

Compact size/low weight/ in-line units

High flow performance

Suitable for panel and wall mounting

Adjustment can be locked

Captive regulator needle will not blow out when unscrewed

Adjusting knob position line

Technical data

Medium:

Compressed air, filtered, lubricated or non-lubricated, inert gases

Operating pressure:

15 to 145 psig (1-10 bar)

5 to 145 psig (0.3 to 10 bar) -M5

Operating temperature:

0° to 175°F* (-20° to 80°C)

*Consult our Technical Service for use below 35°F (2°C)

Materials

1/8, 1/4, 3/8, 1/2: Aluminum alloy body, Nitrile seals, brass needle and internal parts, external parts in aluminum alloy.

M5: Aluminum alloy body, nitrile seals and brass needle.

Model T1000A and T1000C

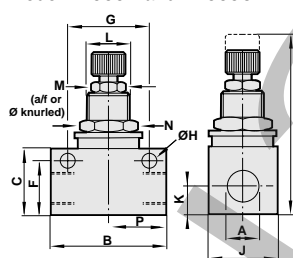

Model T1000M

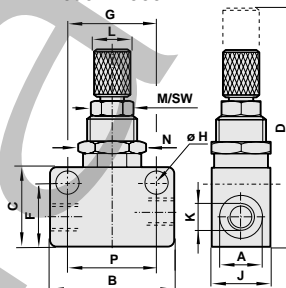

Model	Cv Regulating NPT port	Cv Free Flow NPT port	Weight grams oz. (g)
T1000M0500	0.07	0.07	.0007 (.020)
T1000A1800	0.14	0.37	1.1 (31)
T1000A2800	0.32	0.69	2.0 (56)
T1000A3800	1.00	1.45	5.3 (150)
T1000A4800	1.60	1.90	6.3(180)

Model	A	B	C	D	F	G	H	J	K	L	A/F		N	P	Panel Hole	Max Panel Thickness
											M	M				
T1000A1800	1/8 NPT	1.33	0.79	2.0	0.65	0.94	0.18	0.63	0.38	M12 x 1	0.39	0.55	0.67	0.49	0.16	
T1000A2800	1/4 NPT	1.77	1.0	2.42	0.82	1.26	0.18	0.75	0.38	M14 x 1	0.39	0.67	0.89	0.57	0.16	
T1000A3800	3/8 NPT	2.28	1.28	3.09	1.06	1.69	0.26	1.10	0.51	M20 x 1	0.39(a/f)	0.94	1.14	0.81	0.16	
T1000A4800	1/2 NPT	2.56	1.42	3.23	1.20	1.97	0.26	1.18	0.29	M20 x 1	0.39 (a/f)	0.94	1.28	0.81	0.16	
T1000M0500	M5	0.98	0.59	1.77	0.47	0.70	0.17	0.47	0.21	M10x.75	0.31	0.47	0.49	0.41	0.15	
T1000C1800	G1/8	1.33	0.78	2.0	0.64	0.94	0.17	0.62	0.31	M12 x 1	0.39	0.55	0.66	0.49	0.15	
T1000C2800	G1/4	1.77	1.0	2.42	0.82	1.26	0.17	0.74	0.37	M14 x 1	0.39	0.66	0.88	0.57	0.15	
T1000C3800	G3/8	2.28	1.27	3.9	1.06	1.69	0.25	1.1	0.51	M20 x 1	0.55	0.94	1.14	0.80	0.15	
T1000C4800	G1/2	2.55	1.41	3.22	1.20	1.96	0.25	1.18	0.59	M20 x 1	0.55	0.94	1.27	0.8	0.15	

Flow vs Turns at 90 psi (6 bar)

T1000A1800

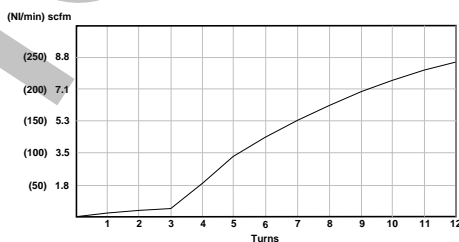

T1000A2800

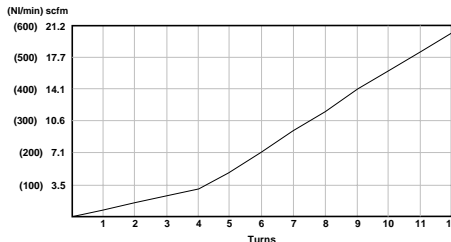

T1000A3800

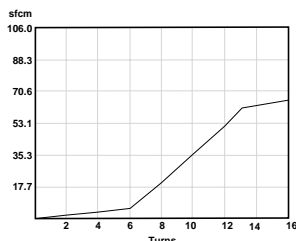

T1000A4800

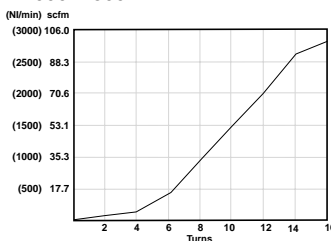

T1000M0500 (M5)

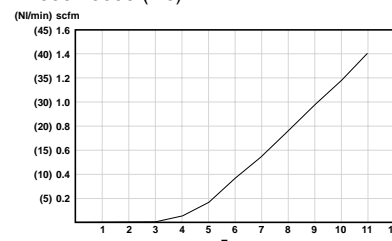

Fittings

Pneufit C In-line Flow Controls

Inch and metric

Releasable stainless-steel grab-ring to grip nylon or polyurethane tube (85 or 95 durometer).

Nickel plated brass components provide corrosion and contamination resistance and an extended life.

Pre applied thread sealant on all taper threads and recessed captive O-ring on parallel threads provides optimum rapid sealing.

Immediate quality sealing using silicone free U-packaging.

Mounting holes on all union fittings

Technical data

Medium

Compressed air

Operating pressure

29.5" Hg vacuum up to 150 psi

Temperature

32°F to 140°F

Materials

Body: PBT

Seals: NBR (silicone free) u-packaging and O-rings

Threaded bodies: nickel plated brass

Release sleeve and backing ring: POM

Grab-ring: stainless steel

Collar: nickel plated brass

Thread sealant: threebond 2350B



C20G

Pneufit C inch In-line flow control

ØD	L		C	H	B	
	min	max				
5/32	1.18	1.31	0.13	1.78	0.64	C20GE0200
3/16	1.38	1.56	0.17	1.98	0.66	C20GE0300
1/4	1.38	1.56	0.17	1.98	0.69	C20GE0400
5/16	1.47	1.66	0.17	2.19	0.74	C20GE0500
3/8	1.72	1.93	0.17	2.41	0.80	C20GE0600
1/2	1.87	2.11	0.17	2.75	0.87	C20GE0700

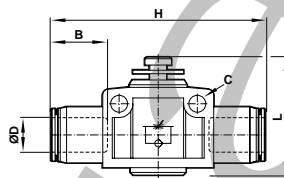

C00G

Pneufit C metric In-Line Flow Control

ØD	L		C	H	B	
	min	max				
4.0	29.9	33.3	3.3	45.1	16.3	C00GE0400
6.0	35.0	39.5	4.3	50.3	17.6	C00GE0600
8.0	37.4	42.1	4.4	55.7	18.7	C00GE0800
10.0	43.8	49.0	4.4	61.2	19.6	C00GE1000
12.0	47.7	53.6	4.4	69.8	21.9	C00GE1200

Pneufit C In-line Flow Controls

Inch and metric

Speed Controllers Flowrate for C20GE (inch) and C00GE (mm) Banjo Types

C20GE0200
C00GE0400

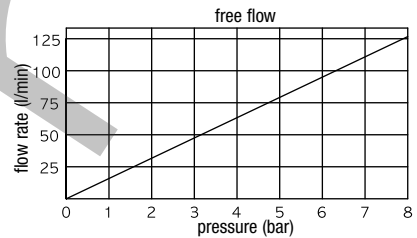
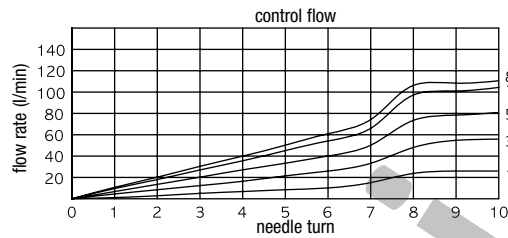

C20GE0400
C00GE0600

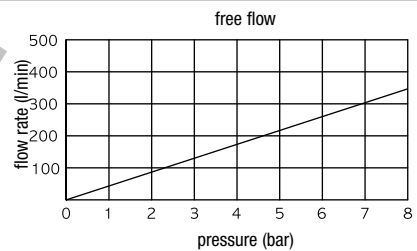
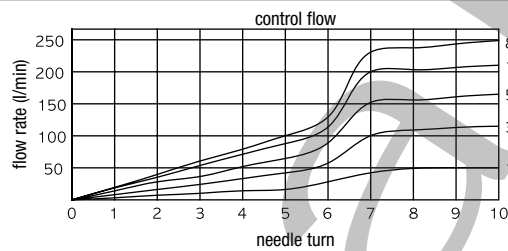

C20GE0500
C00GE0800

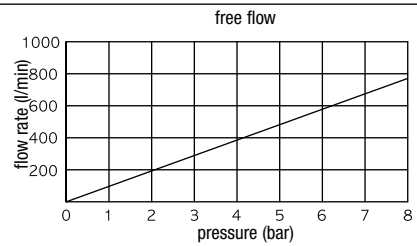
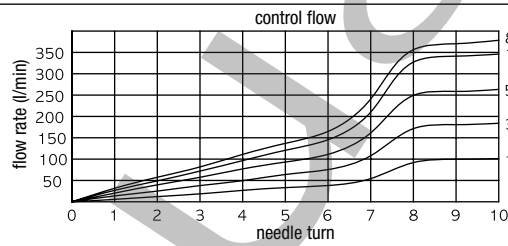

C20GE0600
C00GE1000

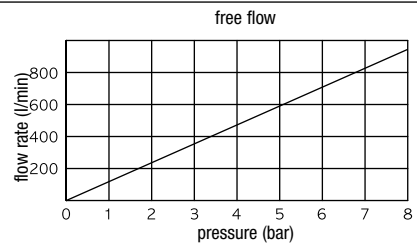
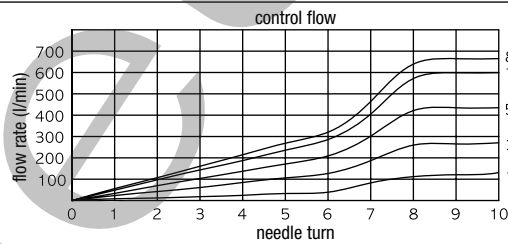

C20GE0700
C00GE1200

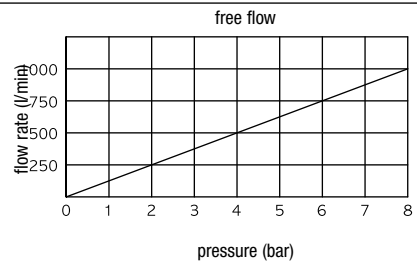
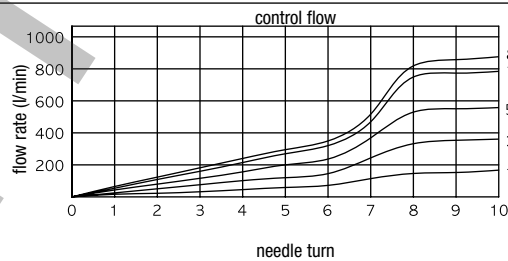

Fittings

M/800, C/800 Series

Heavy duty flow controls

In-line

1/8", 1/4", 1/2", 3/4", 1"

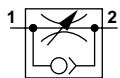

Line mounted general purpose regulators

Captive regulating needle will not blow out when unscrewed
Calibrated adjusting knob, can be locked

Suitable for wall mounting

High operating pressure

Technical data

Medium:

Compressed air, filtered, lubricated and non-lubricated

Operating pressure:

5 to 230 psig (0.3 to 16 bar)

Operating temperature:

0°F to 175°F (-20°C to + 80°C)
(Alternative models to 300°F [150°C])

Consult our Technical Service for use below 35°F (+2°C)

Materials

S/836, M/837, M/839:

Body, adjusting knob and locking ring: brass

M/840, M/855:

Body, adjusting knob and locking ring: aluminum

Seals: nitrile rubber.

Alternative models

T1000 range of block form flow controls, see website

TM, TC/800 High temperature version (150°C max.).

T15 range In-line push-in flow controls, see website

C20GE series inline push-in flow controls

Port	Model	ISO G	Max. Regulating Flow Cv	Max. Free Flow Cv
1/8	C/836	S/836	0.17	0.6
1/4	C/837	M/837	0.49	1.0
1/2	C/839	M/839	2.6	3.6
3/4	C/840	M/840	3.7	6.5
1	C/855	M/855	8.4	8.9

Thread	NPT	G	A	L	C	B	M (max)	D
1/8	C/836	S/836	.96	1.81	1.06	.33	3.11	.67
1/4	C/837	M/837	1.63	2.36	.98	.20	1.46	.87
1/2	C/839	M/839	2.25	3.7	2.09	.33	3.11	1.10
3/4	C/840	M/840	2.99	4.69	2.60	.34	4.09	1.38
1	C/855	M/855	3.54	5.90	4.22	.51	5.79	2.04

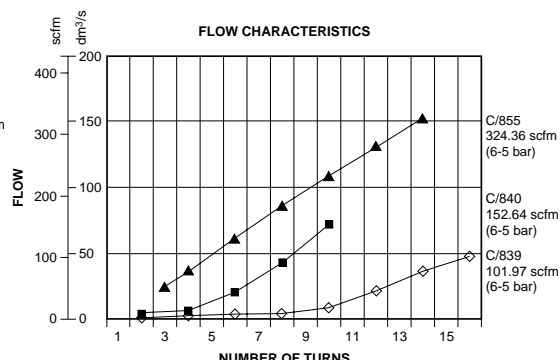
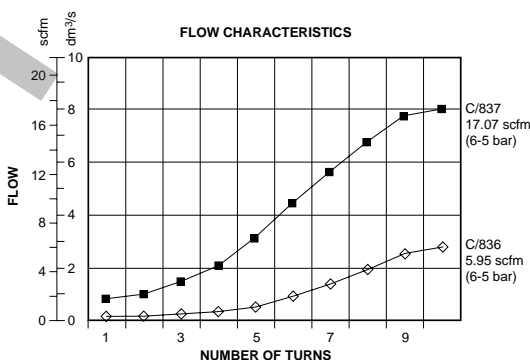
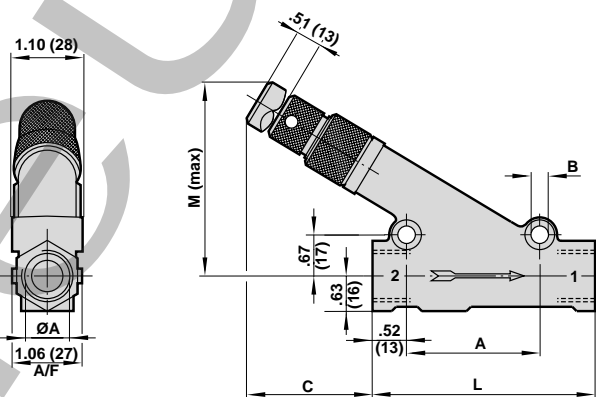

T51, T52 and T53 Series

Push-in non-return valves

In-line

Ø 5/32", 3/16", 1/4", 5/16", 1/2" inch O/D tube

Ø 4, 6, 8, 10, 12 mm O/D tube



Low cracking pressure

Releasable grab ring technology

combining plastic and brass components for a compact and superior fitting design

Non-PTFE based thread sealant on taper threads

Molded mounting brackets on tube connector designs (PIF/PIF connection)

Red release sleeve indicating metric tube sizes

Grey release sleeve indicating inch tube sizes

Reliable and corrosion resistant

Technical data

Medium:

Compressed air, filtered, lubricated or non-lubricated, vacuum

Operating pressure:

1.5 to 145 psig (0.1 to 10 bar) (T51, T52)

4.4 to 145 psig (0.3 to 10 bar) (T53)

3" to 30" Hg (-0.1 to -1 bar) vacuum (T51, T52)

Ambient temperature:

0° to 175°F (-20° to +80°C)

Consult our Technical Service for use below 35°F (2°C)

Mounting:

Tube/tube PIF

Tube PIF/male thread

Male threaded/tube PIF

Materials

4 mm to 8 mm, 5/32" up to 5/16" OD:

Body: Plastic PBT

Seal: silicon free nitrile

Valve: plastic PBT

Natural brass insert

Spring: stainless steel

Grab ring: stainless steel, (4-6-8 sizes, and 5/32" to 5/16")

O/D 5 fitted with collet connection

T52 and T53 series, nickel brass threads.

3/8" and 1/2", O/D 10 to O/D 12

Collet: nickel plated brass

Body: black anodized aluminum

Valve and insert: aluminum



T51

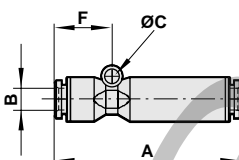

Inch

Inch Model	A	B	F	ØC
T51Y0002	2.0	5/32	0.6	0.2
T51Y0003*	2.1	3/16	0.6	0.2
T51Y0004	2.2	1/4	0.7	0.2
T51Y0005	2.5	5/16	0.7	0.2
T51Y0006*	3.0	3/8	-	-
T51Y0007*	3.5	1/2	-	-

Inch PIF/PIF Model #	Metric PIF/PIF Model #
5/32" T51Y0002	4 T51P0004
3/16" T51Y0003*	5 T51P0005*
1/4" T51Y0004	6 T51P0006
5/16" T51Y0005	8 T51P0008
3/8" T51Y0006*	10 T51P0010*
1/2" T51Y0007*	12 T51P0012*

* Available only with collet tube connection

Metric

Metric Model	A	B	F	ØC
T51P0004	48.8	4	15.5	4.3
T51P0005*	53.1	5	15.2	4.3
T51P0006	55.3	6	16.9	4.3
T51P0008	62.5	8	19.0	4.3
T51P0010*	77.4	10	-	-
T51P0012*	88.4	12	-	-

T52, T53

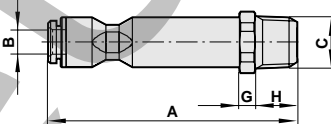

Inch PIF/Male Thrd.	Metric PIF/ISO Rc	Inch Model #	Metric Model #
5/32" x 1/8"	4 x M5	T52A1802	T52M0504
3/16" x 1/8"	4 x 1/8"	T52A1803*	T52B1804
3/16" x 1/4"	5 x 1/8"	T52A2803*	T52B1805*
1/4" x 1/8"	5 x 1/4"	T52A1804	T52B2805*
1/4" x 1/4"	6 x 1/8"	T52A2804	T52B1806
5/16" x 1/8"	6 x 1/4"	T52A1805*	T52B2806
5/16" x 1/4"	8 x 1/8"	T52A2805	T52B1808
5/16" x 1/4"	8 x 1/4"	T52A2805	T52B2808

Inch Male Thrd./PIF	Metric ISO Rc/PIF	Inch Model #	Metric Model #
1/8 x 5/32"	M5 x 4	T53A1802	T53M0504
1/8 x 3/16"	1/8 x 4	T53A1803*	T53B1804
1/4 x 3/16"	1/8 x 5	T53A2803*	T53B1805*
1/8 x 1/4"	1/4 x 5	T53A1804	T53B2805*
1/4 x 1/4"	1/8 x 6	T53A2804	T53B1806
1/8 x 5/16"	1/4 x 6	T53A1805	T53B2806
1/4 x 5/16"	1/8 x 8	T53A2805	T53B1808
1/4 x 5/16"	1/4 x 8	T53A2805	T53B2808

Inch Model	A	B	C**	G	H
T52A1802	2.1	5/32	1/8	0.2	0.4
T52A1803*	2.3	3/16	1/8	0.2	0.4
T52A2803*	2.5	3/16	1/4	0.2	0.6
T52A1804	2.3	1/4	1/8	0.2	0.4
T52A2804	2.5	1/4	1/4	0.2	0.6
T52A1805	2.5	1/8	1/8	0.2	0.4
T52A2805	2.7	1/4	1/4	0.2	0.6

Metric Model	A	B	C**	G	H
T52M0504	49.2	4	M5	4	4.3
T52B1804	54.4	4	1/8	4	9.5
T52B1805*	57.9	5	1/8	4	9.5
T52B2805*	59.4	5	1/4	4	11
T52B1806	59.2	6	1/8	4	9.5
T52B2806	60.7	6	1/4	4	11
T52B1808	63.7	8	1/8	4	9.5
T52B2808	65.2	8	1/4	4	11

* Available only with collet tube connection

** NPTF

** BSPT

Alternative models

T55, T56 range of aluminum threaded check valves.

C/520 range of brass threaded check valve, see page ???

Fittings

Air fuses

In-line excess flow shut-off valves

1/4 ... 1-1/2 NPT

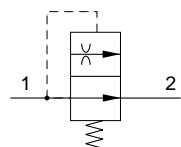

Assists in complying with safety regulations.

Tamper proof.

Compact and safe design.

Low pressure drop.

Automatically resets after failure correction.

High corrosion resistance.

High air pressure rating.

Technical data

Medium:

Compressed air, filtered, lubricated and non lubricated inert gases

Operating pressure:

Maximum 232 psi (16 bar)

Minimum according to hose length
Drop pressure at shut-off flow: 2 to 4.5 psi (0.14 or 0.3 bar)

Mounting:

In-line two way valve. To be inserted between fixed air supply and flexible hose air line. See guidelines for typical installation.

Operating temperature:

0^{***} to 175° F (-20° to 80°C)

**Consult our Technical Service for use below 35°F (2°C)

At low temperature ensure air fuse is not subjected to freezing conditions which may prevent its function.

Materials

Body: aluminum

Internal parts: brass

Spring: stainless steel

Model	Drop pressure at shut off flow (psi)	Shut off flow rate at 100 psi	Flow at 100 psi DP 1 psi (scfm)	Weight oz.
T60A2890	2.0	17.6	13.8	1.4
T60A2891	4.4	29.7	13.8	1.4
T60A3890	2.0	41.1	28.6	2.3
T60A3891	4.4	68.2	28.6	2.3
T60A4890	2.0	68.2	49.2	5.3
T60A4891	4.4	102.3	49.2	5.3
T60A6890	2.0	102.3	91.1	4.6
T60A6891	4.4	169.5	91.1	4.6
T60A8890	2.0	195.0	144	19.0
T60A8891	4.4	271.0	144	19.0
T60AB890	2.0	394.0	307	38.8
T60AB891	4.4	568.0	307	38.8

NPT : according to ANSI-B1.20.1.

ISO G : according to BS2779 and ISO-228/1

Flow and pressure test conducted according to ISO-6358 test circuit. Mean measured flow values are provided at standard reference conditions.

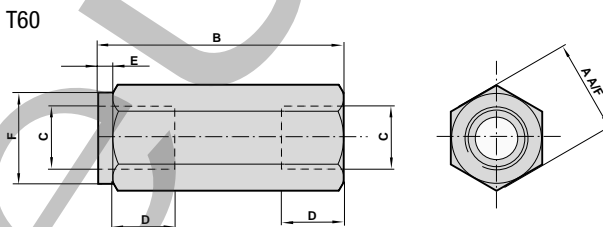

Model	T60A289	T60C289	T60A389	T60C389	T60A489	T60C489	T60A689	T60C689	T60A889	T60C889	T60AB89	T60CB89
	NPT	ISO G	NPT	ISO G	NPT	ISO G	NPT	ISO G	NPT	ISO G	NPT	ISO G
A	0.81	0.81	0.94	0.94	1.25	1.25	1.25	1.25	2.00	2.00	2.50	2.50
B	2.01	2.01	2.44	2.44	3.07	3.07	3.54	3.54	4.65	4.65	5.71	5.71
C	1/4	1/4	3/8	3/8	1/2	1/2	3/4	3/4	1.0	1.0	1.5	1.5
D	0.39	0.43	0.41	0.55	0.59	0.54	0.56	0.75	0.66	1.00	0.68	1.00
E	0.12	0.12	0.20	0.20	0.20	0.20	0.20	0.20	0.20	0.20	0.20	0.20
F	0.81	0.81	0.94	0.94	1.25	1.25	1.25	1.25	2.00	2.00	2.50	2.50

Guidelines for typical installation

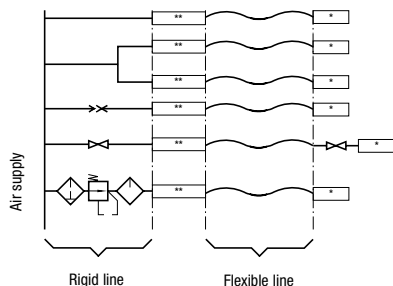

The air fuse should be installed directly between fixed or rigid pipework and the flexible tube to protect the whole length of the flexible tube. Only tubing after the air fuse is protected. The air fuse must be installed in the correct orientation. Failure to do this will render it ineffective. When a shut off valve is located before the air fuse, the valve must be opened slowly in order to control initial air flow and avoid decompression effects which may trip the air fuse.

It should be noted that the OSHA standard (29 CFR ChXVII Para 1926.302-b7) relating to pneumatic power tools states "All hoses exceeding 1/2" inside diameter shall have a safety device at the source of supply or branch line to reduce pressure in the case of hose failure."

Air Fuses

In-line excess flow shut-off valves

1/4" to 1-1/2"

How to select an air fuse

- The port size of the air fuse should be nominally equal to that of the supply lines e.g. a 1/2" (12,7mm) air fuse should be used with a 1/2" (12,7mm) ID hose.
- Always select the high flow model (91) if there is sufficient system pressure for the length of hose to be protected. See tables hose length vs minimum supply pressure.
- If there is insufficient system pressure, or long hose lengths are to be protected, use model 90.
- After installation always test each valve for proper function. See section how to check an air fuse below.
- The pneumatic system must be capable of delivering the flow required to activate the air fuse.
- For use with spring coils consult table. See table flow vs pressure supply.

How to check an air fuse

- * Install air fuse following the instructions supplied
- * Connect tool or complete circuit to the air line
- * Switch on operation to ensure a complete cycle is performed
- * If tool or complete circuit starts and runs satisfactorily, stop operation and drain air line. Disconnect hose from tool or circuit and secure hose end. Turn on air supply progressively (to avoid decompression effect). Prior to fully reaching operation conditions, the valve should suddenly activate and cut off the flow. A slight air flow will remain as part of the automatic re-set function. If the air fuse is not activated the unit should be disconnected and the lower flow range air fuse should be used.

Coiled hose selection table

Selection procedure for coiled hose:

Choose the thread size of your hose, the hose internal diameter in inches and the hose length in feet. The minimum supply pressure in psi is shown in the table below and the appropriate air fuse is shown in the left column. The "*" in the middle of the part number represents the thread type - put an "A" for NPT and a "C" for ISO G threads. If no value is shown, it may not be possible to protect your hose with an air fuse. If in doubt, consult a Norgren distributor or Norgren.

Valve Model	Thread Size	Hose length Feet	Internal Hose Diameter (inch)											
			0.125	0.188	0.215	0.250	0.313	0.370	0.470	0.500	0.590	0.750	1.000	1.250
T60*2890	1/4	12		124	64	29	16	11	8	8	7	7	7	7
T60*2890	1/4	25			126	52	25	14	9	9	8	7	7	7
T60*2890	1/4	50			244	97	42	21	11	10	8	8	7	7
T60*2890	1/4	100				187	76	35	15	13	10	8	7	7
T60*2891	1/4	12				70	31	17	10	9	8	7	7	7
T60*2891	1/4	25				137	57	27	13	11	9	8	7	7
T60*2891	1/4	50					107	47	19	15	11	8	7	7
T60*2891	1/4	100					207	87	30	23	14	9	8	7
T60*3890	3/8	12			125	52	25	12	11	9	8	7	7	7
T60*3890	3/8	25				102	45	18	15	10	8	7	7	7
T60*3890	3/8	50				196	82	29	22	14	9	8	7	7
T60*3890	3/8	100					157	50	38	20	11	8	7	7
T60*3891	3/8	12				132	57	21	17	11	8	8	7	7
T60*3891	3/8	25					111	37	28	16	10	8	7	7
T60*3891	3/8	50					215	67	49	25	12	8	8	7
T60*3891	3/8	100						126	91	42	17	9	8	7
T60*4890	1/2	12				132	57	21	17	11	8	8	7	7
T60*4890	1/2	25					111	37	28	16	10	8	7	7
T60*4890	1/2	50					215	67	49	25	12	8	8	7
T60*4890	1/2	100						126	91	42	17	9	8	7
T60*4891	1/2	12					119	39	30	17	10	8	7	7
T60*4891	1/2	25						74	54	27	13	8	8	7
T60*4891	1/2	50						141	102	46	18	10	8	8
T60*4891	1/2	100							196	85	29	12	9	8
T60*6890	3/4	12					119	39	30	17	10	8	7	7
T60*6890	3/4	25						74	54	27	13	8	8	7
T60*6890	3/4	50						141	102	46	18	10	8	8
T60*6890	3/4	100							196	85	29	12	9	8
T60*6891	3/4	12						96	70	33	15	9	8	7
T60*6891	3/4	25						193	139	62	23	11	8	8
T60*6891	3/4	50								116	38	14	9	8
T60*6891	3/4	100								224	69	20	11	9
T60*8890	1	12						123	89	41	17	9	8	7
T60*8890	1	25							178	78	27	12	9	8
T60*8890	1	50								148	47	16	10	8
T60*8890	1	100									88	24	13	9
T60*8891	1	12						231	166	73	26	11	8	8
T60*8891	1	25								144	46	16	10	8
T60*8891	1	50									85	24	12	9
T60*8891	1	100									163	41	17	11
T60*B890	1-1/2	12								147	47	16	10	8
T60*B890	1-1/2	25									90	25	13	9
T60*B890	1-1/2	50									173	43	18	11
T60*B890	1-1/2	100										78	29	16
T60*B891	1-1/2	12									89	25	13	9
T60*B891	1-1/2	25									179	44	18	12
T60*B891	1-1/2	50										81	30	16
T60*B891	1-1/2	100										154	52	24

Fittings

T55/T56 Series

Non-return valves

In-line

M5, 1/8", 1/4", 3/8", 1/2"



Permit free flow of air in one direction only

Simple, reliable design

Silicone free

Low cracking pressure

T56 male connections have an O-ring in parallel threads

Technical data

Medium:

Compressed air, filtered, lubricated and non-lubricated

Operating pressure: 1.5 to 145 psig (0.1 to 10 bar)

Operating temperature: 0°F to 175°F* (-20°C to +80°C)

*Consult our Technical Service for use below 35°F (+2°C)

Materials

Body: aluminum (T55), brass (T56)

O-ring: nitrile rubber

Valve: POM

Spring: stainless steel

Note: Viton seals for high temperature version

Alternative models

T51 Series in-line push-in check valves, see previous page

S/520 Series heavy duty non-return valves for high temperatures, see page ???.

T55 Series

Port Size	Flow Factor Cv**	Cracking pressure	Weight oz	Metric	Model NPT	BSPP	BSPT
M5	0.19	0.73	0.35	T55M0500			
1/8	0.59	0.73	0.53		T55A1800	T55C1800	T55B1800
1/4	1.35	0.73	0.88		T55A2800	T55C2800	T55B2800
3/8	2.20	0.73	2.12		T55A3800	T55C3800	T55B3800
1/2	3.70	0.73	2.82		T55A4800	T55C4800	T55B4800

** Cv measured in US gal/min.

T55

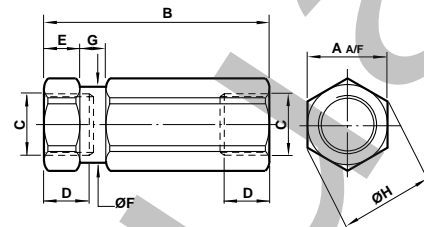

Model	A	B	C	D	E	F	G	H
T55M0500	0.43	1.08	M5	0.20	0.16	0.42	0.12	0.47
T55A1800	0.55	1.67	1/8	-	0.28	0.54	0.16	0.59
T55B1800	0.55	1.67	1/8	-	0.28	0.54	0.16	0.59
T55C1800	0.55	1.67	1/8	0.28	0.28	0.54	0.16	0.59
T55A2800	0.67	2.13	1/4	-	0.31	0.66	0.20	0.73
T55B2800	0.67	2.13	1/4	-	0.31	0.66	0.20	0.73
T55C2800	0.67	2.13	1/4	0.41	0.31	0.66	0.20	0.73
T55A3800	0.94	2.48	3/8	-	0.35	0.93	0.28	1.02
T55B3800	0.94	2.48	3/8	-	0.35	0.93	0.28	1.02
T55C3800	0.94	2.48	3/8	0.47	0.35	0.93	0.28	1.02
T55A4800	1.06	3.03	1/2	-	0.47	1.05	0.39	1.18
T55B4800	1.06	3.03	1/2	-	0.47	1.05	0.39	1.18
T55C4800	1.06	3.03	1/2	0.59	0.47	1.05	0.39	1.18

T56 Series

Port Size	Flow Factor Cv**	Cracking pressure	Weight oz	Model Metric	NPT	BSPP	BSPT
M5	0.19	0.73	0.64	T56M0500			
1/8	0.59	0.73	1.59		T56A1800	T56C1800	T56B1800
1/4	1.23	0.73	2.82		T56A2800	T56C2800	T56B2800

** Cv measured in US gal/min.

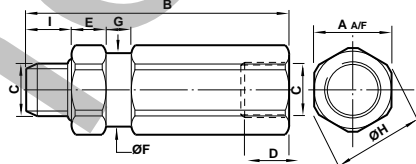

Model	A	B	C	D	F	G	H	I
T56M0500	0.43	1.25	M5	.20	0.42	0.12	0.47	0.17
T56A1800	0.55	1.93	1/8	-	0.54	0.16	0.59	0.37
T56B1800	0.55	1.93	1/8	-	0.54	0.16	0.59	0.37
T56C1800	0.55	1.77	1/8	.28	0.54	0.16	0.59	0.22
T56A2800	0.67	2.46	1/4	-	0.66	0.20	0.73	0.56
T56B2800	0.67	2.32	1/4	-	0.66	0.20	0.73	0.43
T56C2800	0.67	2.21	1/4	.41	0.66	0.20	0.73	0.31

C/523 - C/524 Series

Model NPT	ISO G	Size	Flow factor Cv	Cracking Pressure psi	Weight oz.	Spares Kit	
						NPT	ISO G
C/523	S/523	3/4	6.5	0.9	19.4	QC/523/00	QS/523/00
C/524	S/524	1	8.9	0.9	38.9	QC/524/00	QS/524/00

Note : For high temperature applications a T should be added on spares kit part number (i.e. TQS/520/00)
Initial cracking pressure may be higher if valve has been stored for a long period.

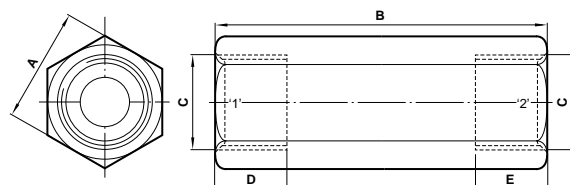

Model	A	B	C	D	E
C/523	1.42	3.6	3/4	0.71	0.71
S/523	1.42	3.6	3/4	0.71	0.71
C/524	1.93	4.88	(1)	0.98	0.98
S/524	1.93	4.88	(1)	0.98	0.98

T65 Series 1/8" and 1/4"

NPT and ISO G Shuttle Valves

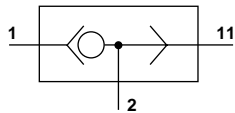

Allows two independent signal sources to be connected to a common pilot line

Can be used to perform an 'OR' logic function

Selects the highest of two applied pressures

Can be combined to operate from three or more sources

Valves can be ganged together

Product Number		Port Size	Flow Factor Cv	Weight oz. (kg)
NPT	ISO G			
T65A1800	T65C1800	1/8	0.42	1.9 (.055)
T65A2800	T65C2800	1/4	0.64	4.6 (.130)

NPT according to ANSI B1.20.1

Technical data

Fluid:
Compressed air, filtered, lubricated and non-lubricated, inert gases

Operation:
Shuttle valve

Mounting:
Through holes in valve body

Port Size:
Female Thread

NPT
1/8 NPT T65A1800
1/4 NPT T65A2800

ISO G
G1/8 T65C1800
G1/4 T65C2800

Operating Pressure:
10 to 145 psi (0.7 - 10 bar)

Operating Temperature:
0° to 175°F (-20°* to +80°C)

*Consult our Technical Service for use below 35°F (2°C)

Materials
Body: Zinc
Ball: Nitrile
Seat: Brass

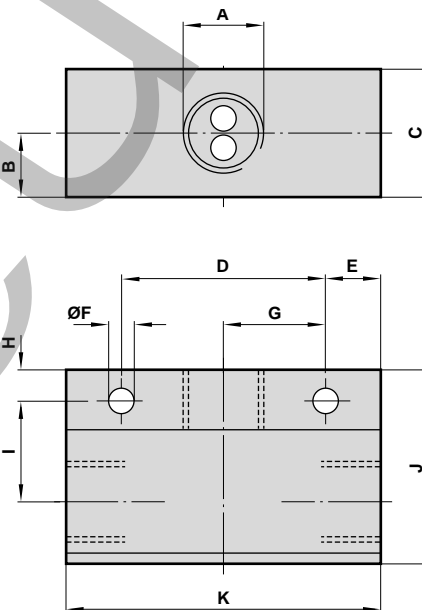

Model	A	B	C	D	E	F	G	H	I	J	K
T65A 1800	1/8 NPT	0.30	0.59	0.79	0.3	0.21	0.39	0.24	0.39	1.00	1.42
T65C 1800	G1/8	0.30	0.59	0.79	0.3	0.21	0.39	0.24	0.39	1.00	1.42
T65A 2800	NPT1/4	0.39	0.79	0.98	0.49	0.21	0.49	0.31	0.47	1.18	2.00
T65C 2800	G1/4	0.39	0.79	0.98	0.49	0.21	0.49	0.31	0.47	1.18	2.00

NPT according to ANSI B1.20.1
G according to BS 2779/ISO 228/1

Fittings

T70, and C/511 Series

Quick exhaust valves

1/8" to 3/4"

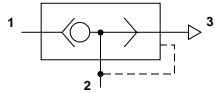

Enables air to be exhausted quickly from air reservoirs and cylinders.

Allows higher cylinder speeds to be achieved.

Simple, compact design and construction.

Very reliable in operation.

Technical data

Medium:

Compressed air, filtered, lubricated and non-lubricated

Operating pressure:

- 7 to 145 psi (0.5 to 10 bar) (T70)
- 10 to 145 psi (0.7 to 10 bar) (S/511)
- 10 to 100 psg (0.7 to 7 bar) (S/513, S/514)

Operating temperature:

-4°F to 176°F (-20°C to +80°C).

Consult our Technical Service for use below 35°F (+2°C).

Materials

Body & cover: zinc alloy (T70*1800 & T70*2800, S/513), aluminum alloy (T70*3800 & T70*4800, S/511, S/514)

Seals: nitrile (T70), polyurethane (S/51*)

O-ring: nitrile

Element: porous plastic (S/513, S/514)

Model	Inlet port	Outlet port	Exhaust port	Cv Flow Factor Direction 1 - 2*	Cv Flow Factor Direction 2 - 3	Weight oz	Repair kit (seals only)
T70A 1800	1/8	1/8	1/8	0.9	1.8	5.3	T70C1800K0
T70A 2800	1/4	1/4	1/4	1.9	2.5	4.6	T70C2800K0
T70A 3800	3/8	3/8	3/8	3.8	5.5	7.4	T70C3800K0
T70A 4800	1/2	1/2	1/2	5.3	5.9	6.7	T70C4800K0
C/511	1/2	3/4	3/4	1.9/5.1**	10.8	11.0	QS/511/00

* Flow factor measured at 87 psi (6 bar) (inlet) guideline direction

** Alternative Cv shown for 14.5 psi (1 bar). For T70 Series, Cv approximately the same as at 6 bar. NPT threads per ANSI B1.20.1

Model	T70A1800	T70C1800	T70A2800	T70C2800	T70A3800	T70C3800	T70A4800	T70C4800	C/511*
A	1/8 NPT	G1/8	1/4 NPT	G1/4	3/8 NPT	G3/8	1/2 NPT	G1/2	1/20 - 3/4
ØB	0.75	0.75	0.75	0.75	1.18	1.18	1.18	1.18	-
C A/F	0.75	0.75	0.75	0.75	1.18	1.18	1.18	1.18	-
D	1.10	1.10	1.10	1.10	1.57	1.57	1.57	1.57	2.0
E A/F	1.18	1.18	1.18	1.18	1.81	1.81	1.81	1.81	1.87
F	0.60	0.60	0.60	0.60	0.61	0.61	0.61	0.61	-
G	0.14	0.14	0.14	0.14	0.16	0.16	0.16	0.16	-
H	2.09	2.09	2.09	2.09	2.89	2.89	2.89	2.89	3.38
ØJ	1.14	1.14	1.14	1.14	1.81	1.81	1.81	1.81	-
K	1.40	1.40	1.40	1.40	1.89	1.89	1.89	1.89	2.72

* Note the shape of the C/511 is different. Consult our technical department for the exact specifications.

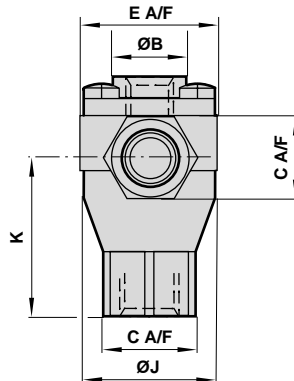
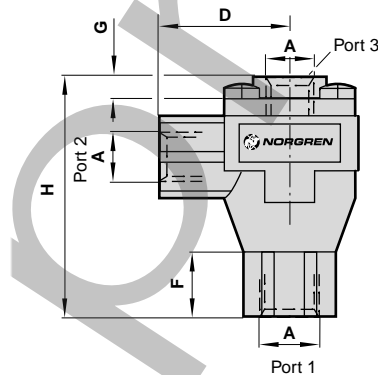

Typical Fill and Exhaust Times (seconds)

Model	Port size	Volume	Fill time	Exhaust time
T70A1800	1/8" NPT	150 cc	0.036	0.021
T70A2800	1/4" NPT	150 cc	0.023	0.017
T70A3800	3/8" NPT	1500 cc	0.110	0.080
T70A4800	1/2" NPT	15,000 cc	0.460	0.480
C/511	3/4" NPT	15,000 cc	0.480	0.250

Note: Fill time is 0 to 80 psg (0 to 5.5 bar), and exhaust time is 101 to 20 psg (7.0 to 1.4 bar)

T15 Series

Push-in flow controls

In-line

Ø 1/8, 5/32, 3/16, 1/4, 5/16, 3/8, 1/2" O/D inch tube

Ø 3, 4, 5, 6, 8, 10, 12 O/D metric tube

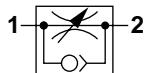

High flow performance

Suitable for panel/wall mounting and manifold

Adjustment can be locked

Captive regulator needle will not blow out when unscrewed

Adjusting knob position

Releasable grab ring technology combining plastic and brass components for a compact and superior fitting design

Red release sleeve indicating metric tube sizes

Grey release sleeve indicating inch tube sizes

Reliable and corrosion resistant

Technical data

Medium:

Filtered, compressed air,

Operation:

Uni-directional flow control

Mounting:

In-line. Panel mounted by hexagonal mounting nut. Wall mounted by through-holes in regulator body. Manifold by quick connection

Operating pressure:

1.5 to 145 psig (0.1 to 10 bar maximum)

Operating temperature:

0° to 175°F (-20° to +80°C)

Consult our Technical Service for use below 35°F (2°C)

Materials

3 mm, 1/8", 5/32", 1/4", 5/16", and 3/8" OD:

Body: plastic PBT

Seals: silicone free nitrile seal

External metal parts: nickel plated brass

Internal parts: brass

Spring: stainless steel

Grab ring: stainless steel

Knob and panel nut: plastic POM

5 mm, 3/16" and 1/2" OD:

Collet: nickel plated brass

Alternative models

Block form flow controls, T1000 series.

Heavy duty flow controls, M/800, and S/790



Inch Tube	Model	Metric Tube	Model	Maxi regulated flow factor Cv**	Free flow factor Cv**	oz (kg)
1/8"	T15Y0001	3 mm	T15P0003	0.3	0.3	.46 (0.013)
5/32"	T15Y0002	4 mm	T15P0004	0.45	0.45	.46 (0.013)
3/16"	T15Y0003*	5 mm	T15P0005*	0.85	0.85	1.13 (0.032)
1/4"	T15Y0004	6 mm	T15P0006	1.3	1.3	.99 (0.028)
5/16"	T15Y0005	8 mm	T15P0008	2.2	2.2	1.66 (0.047)
3/8"	T15Y0006	10 mm	T15P0010	2.9	3.2	3.28 (0.093)
1/2"	T15Y0007*	12 mm	T15P0012*	5.4	5.4	.50 (0.0143)

* Available in collet system

** C measured in dm³/(s.bar) Cv measured in US gal/min

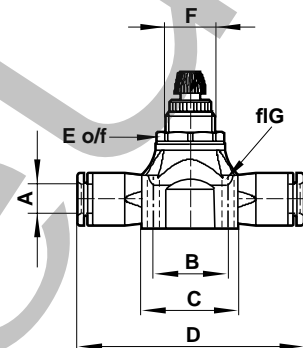

Inch	A	B	C	D	E	F	ØG
T15Y0001	1/8	0.51	0.67	1.81	0.51	M10x1	0.09
T15Y0002	5/32	0.51	0.67	1.81	0.51	M10x1	0.09
T15Y0003	3/16	0.75	0.98	1.93	0.59	M12x1	0.14
T15Y0004	1/4	0.75	0.98	2.17	0.59	M12x1	0.14
T15Y0005	5/16	0.83	1.06	2.58	0.71	M14x1.5	0.14
T15Y0006	3/8	1.04	1.34	3.02	0.94	M20x1.5	0.17
T15Y0007	1/2	1.12	1.42	3.64	0.94	M20x1.5	0.17
Metric	A	B	C	D	E	F	ØG
T15P0003	0.12	0.51	0.67	1.81	0.51	M10x1	0.09
T15P0004	0.16	0.51	0.67	1.81	0.51	M10x1	0.09
T15P0005	0.20	0.75	0.98	1.93	0.59	M12x1	0.14
T15P0006	0.24	0.75	0.98	2.17	0.59	M12x1	0.14
T15P0008	0.31	0.83	1.06	2.58	0.71	M14x1.5	0.14
T15P0010	0.39	1.04	1.34	3.02	0.94	M20x1.5	0.17
T15P0012	0.47	1.12	1.42	3.64	0.94	M20x1.5	0.17

Flow vs turns at 6 bar - flow in dm³/s ANR

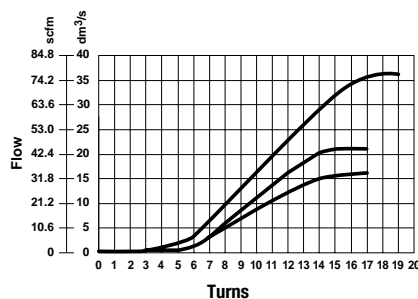

— T15-OD12-1/2
 — T15-OD10-3/8
 — T15-OD8-5/16

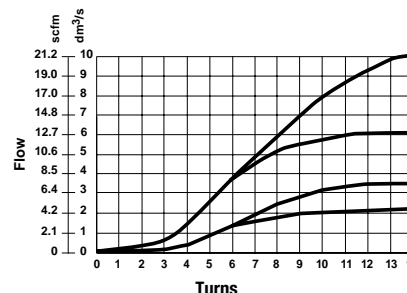

— T15-OD6-1/4
 — T15-OD5-3/16
 — T15-OD4-5/32
 — T15-OD3-1/8