

Nugget 200 Spool Valves

1/4" and 3/8" Solenoid Pilot Actuated
3/2, 5/2, & 5/3 Inline Valves

- Long lasting spool design
- High flow compact valves
- Four mounting styles available
- Wide range of operators and voltages available
- Three functional types: available in 3/2, 5/2, and 5/3 configurations

Technical Data

Medium:

Filtered and lubricated or non-lubricated compressed air or vacuum.

Operation:

Spool valve solenoid pilot actuated.

Mounting:

Stacking – through holes on manifold base.

Inline – through holes in valve body.

Port Size:

PTF – 1/4", 3/8", 1/2"

ISO G – 1/4", 3/8"

Operating Pressure:

Maximum 150 psig (10.3 bar).

Operating Temperature:

-20° to 120°F (-29° to 50°C)

Consult Technical Service for use below 35°F (2°C).

Materials:

Body: Aluminum

Spool: Anodized aluminum

Solenoid Operator Base: plastic

Plunger and spring: Stainless steel

Elastomers: Nitrile and special nitrile-based low-friction elastomers.



Solenoid Operating Specifications

Inlet Pressure Range for Solenoid Operated Valves:

With Internal Pilot Supply: 15 to 150 psig* (1.03 to 10.3 bar)

With External Pilot Supply: 10" Hg vacuum to 150 psig (10.3 bar)

Temperature Range (Ambient/Inlet):

Solenoid Operated Valves: -20° to 120°F** (-29° to 50°C)

Low Wattage Solenoids: -20° to 155°F** (-29° to 68°C)

Operator Pilot Pressures:

Maximum Pilot Pressure: 150 psig (10.3 bar)

Minimum Pilot Pressure at 150 psig (10.3 bar) main valve inlet pressures are given in the following table:

* Minimum Inlet Pressure is dependent on the type of operator and return used. See Operator Pilot Pressure specifications in Operating Specifications.

** With the dew point of supply air less than air temperature below 35°F (2°C)

Minimum Pilot Pressures

Operator	Return psig (bar)	Nondetent psig (bar)	Detented psig (bar)	Spring Centered
Solenoid	Solenoid	15 (1.0)	25 (1.7)	45 (3.1)
Solenoid	Spring	35 (2.4)	–	–

Average Flow Factors in Cv‡ (l/min)

Valve	Port Size	Flow Path	
		Port 1 to 2 1 to 4	Port 2 to 3 4 to 5
3-Port, Inline	1/4"	1.6 (1600)	1.7 (1700)
	3/8"	1.6 (1600)	1.7 (1700)
5-Port, Inline	1/4"	1.6 (1600)	1.7 (1700)
	3/8"	1.6 (1600)	1.7 (1700)

‡ Flow Rating determined in accordance with NFPA/T3.21.3, Pneumatic fluid power – Flow test procedure and reporting method – For fixed orifice components.

Nugget 200 Spool Valves

1/4" and 3/8" Solenoid Pilot Actuated
3/2, 5/2, & 5/3 Inline Valves

Solenoid Pilot Operated Inline Valves

Description	Type	Port Size	Function*	Body**	Operator	Pressure psig	Weight lbs.	Repair Kit
Sol/spring	3/2	1/4"		K41DA00	KS1-KV2	35 - 150	2.22	54237-59
Sol/spring	3/2	3/8"		K41EA00	KS1-KV2	35 - 150	2.22	54237-59
Sol/spring	5/2	1/4"		K71DA00	KS6-KV2	35 - 150	2.22	54237-56
Sol/spring	5/2	3/8"		K71EA00	KS6-KV2	35 - 150	2.22	54237-56
Double Solenoid	3/2	1/4"		K41DA00	KV2-KV2	15 - 150	4.40	54237-59
Double Solenoid	3/2	3/8"		K41EA00	KV2-KV2	15 - 150	4.40	54237-59
Double Solenoid	5/2	1/4"		K71DA00	KV2-KV2	15 - 150	4.40	54237-56
Double Solenoid	5/2	3/8"		K71EA00	KV2-KV2	15 - 150	4.40	54237-56
Double Solenoid	5/3	1/4"	APB	K81DA00	KV0-KV0	15 - 150	4.40	54237-56
Double Solenoid	5/3	3/8"	APB	K81EA00	KV0-KV0	15 - 150	4.40	54237-56
Double Solenoid	5/3	1/4"	COS	K81DA05	KV0-KV0	15 - 150	4.40	54237-57
Double Solenoid	5/3	3/8"	COS	K81EA05	KV0-KV0	15 - 150	4.40	54237-57
Double Solenoid	5/3	1/4"	COE	K81DA06	KV0-KV0	15 - 150	4.40	54237-58
Double Solenoid	5/3	3/8"	COE	K81EA06	KV0-KV0	15 - 150	4.40	54237-58
Double Solenoid	3/2	1/4"		K41DA00	KVL-KVL	25 - 150	4.40	54237-59
Double Solenoid	3/2	3/8"		K41EA00	KVL-KVL	25 - 150	4.40	54237-59
Double Solenoid	5/2	1/4"		K71DA00	KVL-KVL	25 - 150	4.40	54237-56
Double Solenoid	5/2	3/8"		K71EA00	KVL-KVL	25 - 150	4.40	54237-56

* APC - all ports blocked COS - cylinder open to supply COE - cylinder ports open to exhaust

** Standard valves are equipped with PTF threads, solenoid operators with locking overrides, internal pilot, 120V/60 Hz-110V/50 Hz coils and cable grip connectors. Optional solenoid operators, coil voltages and electrical connectors can be ordered using the information on the web address.

Vacuum service available with externally piloted valves.

Note: For ISO-G threads, insert "G" in the 5th position.

Solenoid Pilot Operators

Position	Operator PTF	ISO G	Description	Operating Pressure psig	Weight lbs.	Repair Kit
Standard Solenoid Operator with Rotatable Grip Connector*						
2-Position Valves	KV1	KVB	non-locking override, nondetented, internal pilot	15 - 150	.53	54344-17
	KV2	KVC	locking override, nondetented, internal pilot	15 - 150	.53	54344-17
	KV4	KVE	non-locking override, nondetented, external pilot	15 - 150	.53	54344-17
	KV5	KVF	locking override, nondetented, external pilot	15 - 150	.53	54344-17
	KV6	KVG	non-locking override, detented, internal pilot	15 - 150	.53	54344-17
	KVL	KVN	locking override, detented, internal pilot	15 - 150	.53	54344-17
3-Position Valves	KV8	KVJ	non-locking override, spring centered, internal pilot	45 - 150	.53	54344-17
	KV0	KVA	locking override, spring centered, internal pilot	45 - 150	.53	54344-17
	KV3	KVD	non-locking override, spring centered, external pilot	15 - 150	.53	54344-17
Standard Solenoid Operator without Electrical Connector*						
2-Position Valves	K11	K1B	non-locking override, nondetented, internal pilot	15 - 150	.53	54344-17
	K16	K1G	non-locking override, detented, internal pilot	15 - 150	.53	54344-17
	K1L	K1N	locking override, detented, internal pilot	15 - 150	.53	54344-17
3-Position	K10	K1A	locking override, spring centered, internal pilot	45 - 150	.53	54344-17

* Standard voltage is 110/1250 AC 50/60 Hz. For optional voltages add three characters to the end of the part number. For low wattage options contact Application Engineering.

** For external pilot options contact Application Engineering.

† Electrical connectors for KQX series solenoid operators go to web address.

Valves

Nugget 200 Spool Valves

1/4" and 3/8" Solenoid Pilot Actuated
3/2, 5/2, & 5/3 Inline Valves

Dimensions in inches (mm)

- KUx/KVx Series (cable grip)
- K2x/K3x Series (conduit)
- K4x/K5x Series (molded cord)

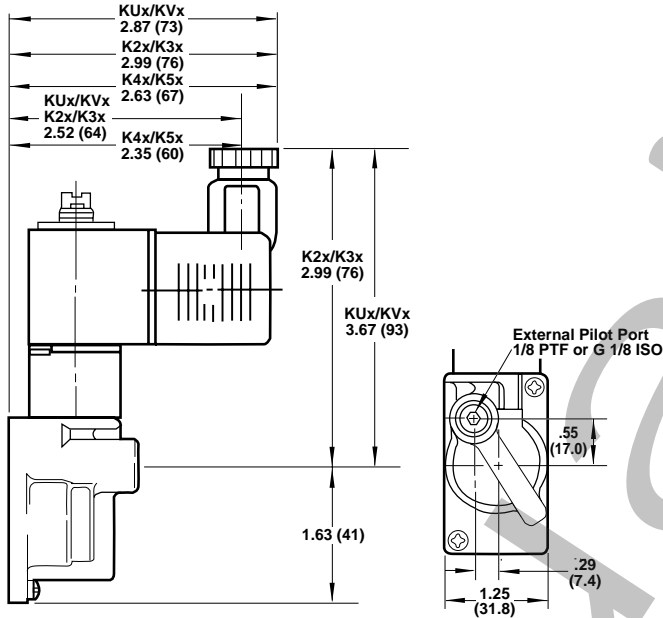

Inline Bodies

3-WAY - 1/4" & 3/8" PORTS
K41

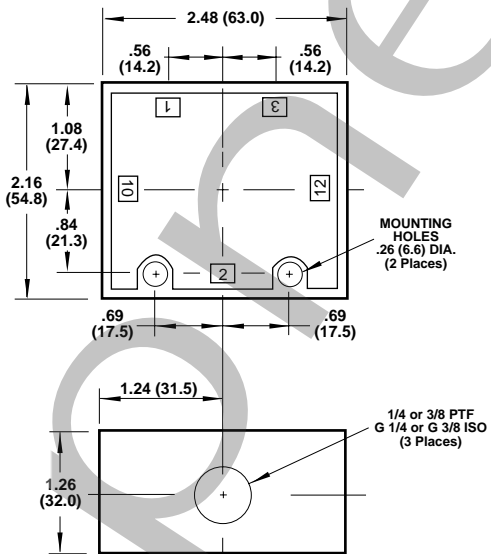

4-WAY - 1/4" & 3/8" PORTS
K71 or K81

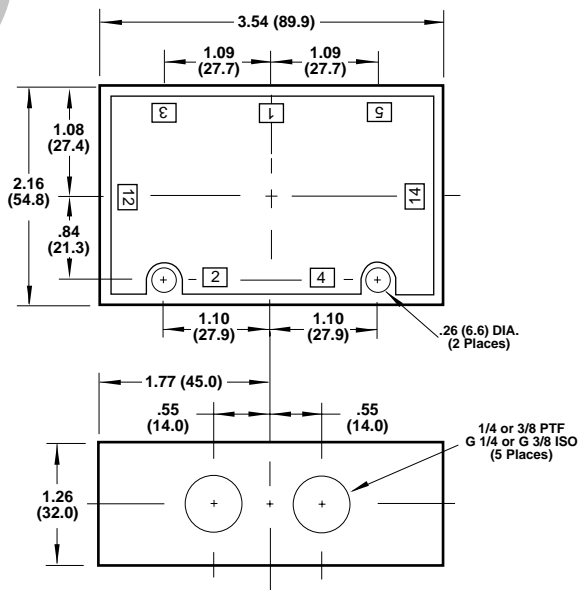

Nugget 200 Spool Valves

1/4", 3/8", and 1/2" Air Pilot Actuated
3/2, 5/2, & 5/3 Inline and Stacking Valves



Long lasting spool design

High flow compact valves

Four mounting styles: inline, stacking valve assemblies, stacking valve assemblies with junction box, and fixed length manifold.

Three functional types: available in 3/2, 5/2, and 5/3 configurations

Technical Data

Medium:

Filtered and lubricated or non-lubricated compressed air or vacuum.

Operation:

Spool valve air pilot actuated.

Mounting:

Stacking – through holes on manifold base.

Inline – through holes in valve body.

Port Size:

PTF – 1/4", 3/8", 1/2"

ISO G – 1/4", 3/8" .

Operating Pressure:

10 Hg vacuum to 150 psig (10.3 bar).

For details see overleaf.

Operating Temperature:

-20° to 160°F (-29° to 71°C)

Consult Technical Service for use below 35°F (2°C).

Materials:

Body: Aluminum

Spool: Anodized aluminum

Solenoid Operator Base: plastic

Plunger and spring: Stainless steel

Elastomers: Nitrile and special nitrile based low-friction elastomers.

Minimum Pilot Pressures

Operator	Return	Nondetent psig (bar)	Detented psig (bar)	Spring Centered psig (bar)
Large Air	Large Air	15 (1.0)	25 (1.7)	45 (3.1)
Large Air †	Small Air	35 (2.4)	–	–
Small Air	Small Air	25 (1.7)	–	–
Large Air	Spring	35 (2.4)	–	–
Low Pressure Air ††	Spring	4 (.27)	–	–
Small Air	Spring	65 (4.5)	–	–
Air Bleed	Air Bleed	15 (1.0)	25 (1.7)	–
Air Bleed	Spring	35 (2.4)	–	–

† Pressure applied simultaneously to both operators. The piston area of the KA2 operator is approximately twice that of the KA1 operator.

†† Pressure applied to port B of KA6 operator (port A open). A minimum vacuum of 6.1 inches Hg (KS1 return) applied to A (port B open) will also operate the valve. The KA6 operator can also be used as a differential pressure operator with or without return spring. The differential pressure required to shift the valve without return spring is less than 1 psig (2" Hg). To reduce the possibility of internal contamination, it is suggested that a filter/breather be installed in the port.

Average Flow Factors in Cv‡ (l/min)

Valve	Port Size	Flow Path	
		Port 1 to 2 1 to 4	Port 2 to 3 4 to 5
3-Port, Inline	1/4"	1.6 (1600)	1.7 (1700)
	3/8"	1.6 (1600)	1.7 (1700)
5-Port, Inline	1/4"	1.6 (1600)	1.7 (1700)
	3/8"	1.6 (1600)	1.7 (1700)
	1/2"	1.6 (1600)	1.7 (1700)
5-Port, Stacking	1/4"	1.8 (1800)	1.4 (1400)
	3/8"	1.8 (1800)	1.4 (1400)

‡ Flow Rating determined in accordance with NFPA/T3.21.3, Pneumatic fluid power – Flow test procedure and reporting method – For fixed orifice components.

Valves

Nugget 200 Spool Valves

1/4", 3/8", and 1/2" Air Pilot Actuated
3/2, 5/2, & 5/3 Inline and Stacking Valves

Air Pilot Operated Inlinde Valves

Description	Type	Port Size	Body*	Operator	Pilot Pressure psig	Weight lbs.	Repair Kit
Air/spring	3/2	1/4"	K41DA00	KS1-KA2	35 - 150	2.22	54237-59
Air/spring	3/2	3/8"	K41EA00	KS1-KA2	35 - 150	2.22	54237-59
Air/spring	5/2	1/4"	K71DA00	KS6-KA2	35 - 150	2.22	54237-56
Air/spring	5/2	3/8"	K71EA00	KS6-KA2	35 - 150	2.22	54237-56
Air/spring	5/2	1/2"	K71FA00	KS6-KA2	35 - 150	2.22	54237-56
Air/Air	3/2	1/4"	K41DA00	KA2-KA2	15 - 150	4.40	54237-59
Air/Air	3/2	3/8"	K41EA00	KA2-KA2	15 - 150	4.40	54237-59
Air/Air	5/2	1/4"	K71DA00	KA2-KA2	15 - 150	4.40	54237-56
Air/Air	5/2	3/8"	K71EA00	KA2-KA2	15 - 150	4.40	54237-56
Air/Air	5/2	1/2"	K71FA00	KA2-KA2	15 - 150	4.40	54237-56
Air/Air	5/3	1/4"	K81DA00	KAC-KAC	45 - 150	4.40	54237-56
Air/Air	5/3	3/8"	K81EA00	KAC-KAC	45 - 150	4.40	54237-56
Air/Air	5/3	1/2"	K81FA00	KAC-KAC	45 - 150	4.40	54237-56
Air/Air	5/3	1/4"	K81DA05	KAC-KAC	45 - 150	4.40	54237-57
Air/Air	5/3	3/8"	K81EA05	KAC-KAC	45 - 150	4.40	54237-57
Air/Air	5/3	1/2"	K81FA05	KAC-KAC	45 - 150	4.40	54237-57
Air/Air	5/3	1/4"	K81DA06	KAC-KAC	45 - 150	4.40	54237-58
Air/Air	5/3	3/8"	K81EA06	KAC-KAC	45 - 150	4.40	54237-58
Air/Air	5/3	1/2"	K81FA06	KAC-KAC	45 - 150	4.40	54237-58
Air/Air	3/2	1/4"	K41DA00	KAA-KAA	25 - 150	4.40	54237-59
Air/Air	3/2	3/8"	K41EA00	KAA-KAA	25 - 150	4.40	54237-59
Air/Air	5/2	1/4"	K71DA00	KAA-KAA	25 - 150	4.40	54237-56
Air/Air	5/2	3/8"	K71EA00	KAA-KAA	25 - 150	4.40	54237-56
Air/Air	5/2	1/2"	K71FA00	KAA-KAA	25 - 150	4.40	54237-56

* Standard valves are equipped with PTF threads. For additional options see our website.
Note: For ISO-G threads, insert "G" in the 5th position. 1/2" ported bodies are not available with ISO G threads.

Air Operators

Position	ISO-G	PTF	Description	Minimum operating Pressure psig (bar)	Weight lbs. (kg)	Repair Kit
2-Position Valves	KAB	KAA	detent, large air	25 (1.7)	0.73 (.33)	54344-16
	KA5	KA2	nondetent, large air	15 (1.0)	0.70 (.32)	54344-16
	KAF	KAE	detent bleed - .02 (.5mm) diameter bleed orifice	25 (1.7)	0.73 (.33)	54344-16
	KA9	KA8	nondetent bleed - .02 (.5mm) diameter bleed orifice	15 (1.0)	0.70 (0.32)	54344-16
	KA7	KA6	nondetent, low pressure (inline only)	4 (.27)	2.46 (1.12)	
	KA4	KA1	nondetent, air bias (small air), return for manual operators or as air bias with KA2 or KA5	25 (1.7)	0.33 (0.15)	54344-16
3-Position Valves	KS5	KS4	nondetent, spring bias, use with KA2 or KA5	35 (2.5)	0.44 (0.20)	54344-16
	KAD	KAC	spring centered	45 (3.1)	0.73 (0.33)	54344-16

Air Operators

KA4/KAF
KA2, KA5
KA8, KA9
LARGE AIR

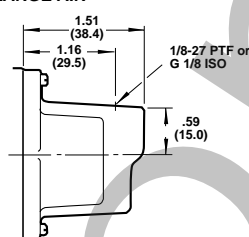

Air Bleed Operators

Constantly bleeds a small amount of air to atmosphere. The valve spool shifts when air bleed is stopped by a customer-supplied on-off valve.

Dimensions in inches (mm)

KA1, KA4
SMALL AIR
(AIR BIAS)

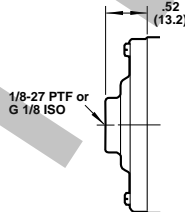

KA1 Air Bias Operator

When pressure is applied to the KA1 operator the valve spool shifts to the KA2 end. When pressure is applied to both the KA1 and KA2 operators the valve spool shifts to the KA1 end.

KS4, KS5
SPRING BIAS

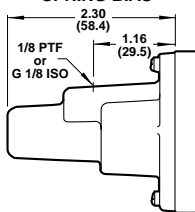

KS4 Spring Bias Operator

Piston area of the KS4 operator is the same as the KA2 operator. The piston of the KS4 operator is spring loaded to shift the valve spool to the KA2 end. The valve spool shifts to the KS4 end when pressure is applied to the KA2 operator. When pressure is applied to both the KS4 and KA2 operators the valve spool shifts to the KA2 end.

KA6, KA7
LOW PRESSURE

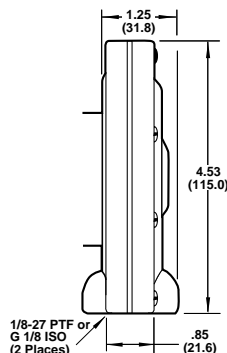

KA6 Low Pressure Operator (inline valves only)

Operator shifts the valve spool with only 4 psig (.28 bar) applied to Port B (Port A open). A minimum vacuum of 6.1" Hg (with KS1 spring return) applied to port A (Port B open) will also operate the valve. Can also be used as a differential pressure operator with or without spring return.

Nugget 200 Spool Valves

1/4", 3/8", or 1/2" Ports, Manual and Mechanical Actuated 3/2, 5/2, & 5/3 Inline and Stacking Valves

Long lasting spool design

High flow compact valves

Wide range of Manual and Mechanical Operators available

Three functional types available in 3/2, 5/2, and 5/3 configurations

Technical Data

Medium:

Filtered and lubricated or non-lubricated compressed air or vacuum.

Operation:

Spool valve manual or mechanical actuation.

Mounting:

Stacking – through holes on manifold base.

Inline – through holes in valve body.

Port Size:

1/4", 3/8", or 1/2" PTF, or 1/4", or 3/8" ISO-G

Operating Pressure:

Maximum 150 psig (10.3 bar). For details see overleaf.

Operating Temperature:

-20°F to 160°F (-29°C to 71°C)

Consult Technical Service for use below 35°F (2°C).

Materials:

Body: Aluminum

Spool: Anodized aluminum

Elastomers: Nitrile and special nitrile-based low-friction elastomers.

Stackable inline lockout valve (1/4")

Compliant with SEMI Standard S2-0200, section 17 "Hazardous Energy Control". This valve is lockable only in the position in which the hazardous energy is removed.

Order Information

K910121: Includes valve assembly with panel mount washer, nut, black knob and lockout key.

Kits

40164-K30: Includes cross bar and tie rods for connecting two valves for simultaneous operation of both valves. Additional kits may be used to create multi-valve manifolds.



Average Flow Factors in Cv‡ (l/min)

Valve	Port Size	Flow Path	
		Port 1 to 2 1 to 4	Port 2 to 3 4 to 5
3-Port, Inline	1/4"	1.6 (1600)	1.7 (1700)
	3/8"	1.6 (1600)	1.7 (1700)
5-Port, Inline	1/4"	1.6 (1600)	1.7 (1700)
	3/8"	1.6 (1600)	1.7 (1700)
	1/2"	1.6 (1600)	1.7 (1700)
5-Port, Stacking	1/4"	1.8 (1800)	1.4 (1400)
	3/8"	1.8 (1800)	1.4 (1400)

‡ Flow Rating determined in accordance with NFPA/T3.21.3, Pneumatic fluid power – Flow test procedure and reporting method – For fixed orifice components.

Manual Operators

Position	Operator	Description	Min. Operating Force lbs. (kg)
2-Position	KB0	Palm Button - Black, Nondetent (Inline Only)	18.0 (8.2)
	KB1	Palm Button - Red, Nondetent (Inline Only)	18.0 (8.2)
	KB2	Palm Button - Green, Nondetent (Inline Only)	18.0 (8.2)
	KB3	Palm Button - Black, Detent (Inline Only)	9.0 (4.1)
	KB4	Palm Button - Red, Detent (Inline Only)	9.0 (4.1)
	KB5	Palm Button - Green, Detent (Inline Only)	9.0 (4.1)
	KF0	Foot Pedal, Nondetent	11.0 (5.0)
	KK0	Knob - Black, Nondetent	18.0 (8.2)
	KK1	Knob - Black, Detent	9.0 (4.1)
	KL0	Lever, Nondetent (Inline Only)	9.0 (4.1)
3-Position	KL1	Lever, 2-Position Detent (Inline Only)	7.0 (3.2)
	KL5	Lever, Nondetent	9.0 (4.1)
	KL6	Lever, 2-Position Detent	7.0 (3.2)
	KT0	Treadle, Nondetent (Inline Only)	13.0 (5.9)
	KT1	Treadle, 2-Position Detent (Inline Only)	9.0 (4.1)
	KB6	Palm Button - Black, Spring Centered	9.0 (4.1)
	KK2	Knob - Black, Spring Centered	9.0 (4.1)
	KK3	Knob - black, 3-Position Detent	9.0 (4.1)
	KL2	Lever, Spring Centered (Inline Only)	7.0 (3.2)
	KL3	Lever, 3-Position Detent (Inline Only)	7.0 (3.2)
	KL7	Lever, Spring Centered	7.0 (3.2)
	KL8	Lever, 3-Position Detent	7.0 (3.2)
KT2	Treadle, Spring Centered	9.0 (4.1)	

Mechanical Operators

Position	Operator	Description	Min. Operating Force lbs. (kg)
2-Position	KP0	Tappet, Nondetent	18.0 (8.2)
	KR2	Lever Roller, Nondetent (Inline Only)	11.0 (5.0)
	KR3	One-Way Trip Roller, Nondetent	11.0 (5.0)
	KR4	Lever Roller, Nondetent	11.0 (5.0)
	KR5	One-Way Trip Roller, Nondetent (Inline Only)	11.0 (5.0)



Nugget 200 Spool Valves

1/4", 3/8", or 1/2" Ports, Manual and Mechanical Actuated 3/2, 5/2, & 5/3 Inline and Stacking Valves

Dimensions in inches (mm)

Mechanical Operators

KP0 – TAPPET

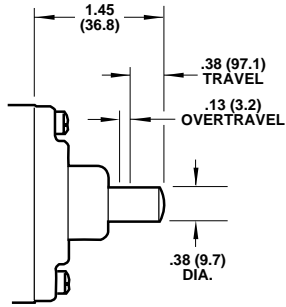

KR2 – LEVER ROLLER

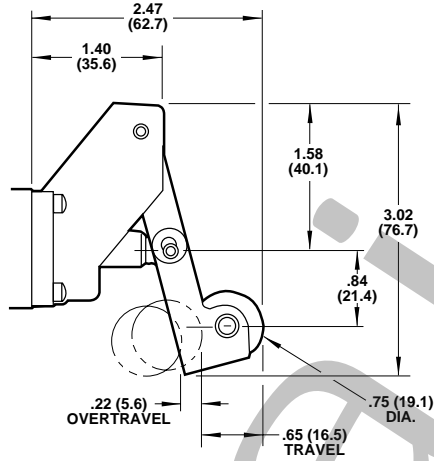

KR4 – LEVER ROLLER

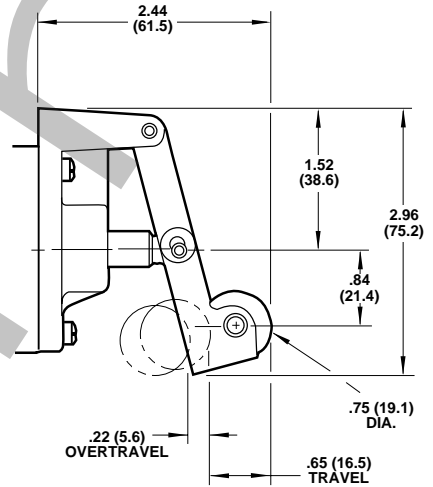

KR5 – LEVER ROLLER
ONE-WAY TRIP

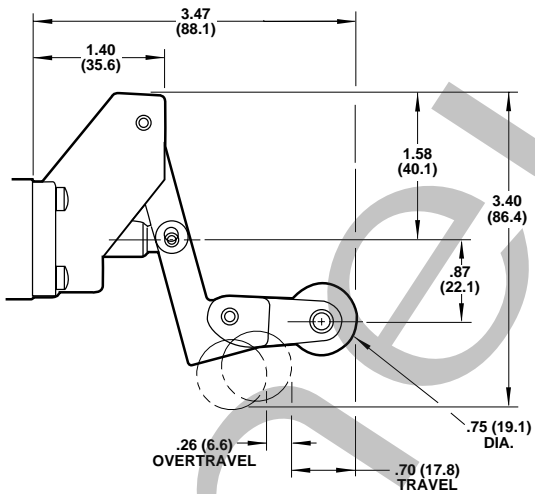

KR3 – LEVER ROLLER
ONE-WAY TRIP

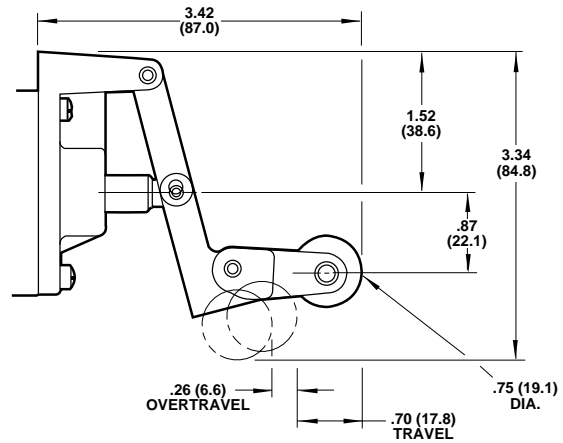

Spring Return & End Cap

KS6 Spring Return

KS1 – SPRING RETURN
(5/2)

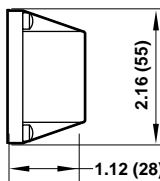
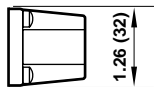
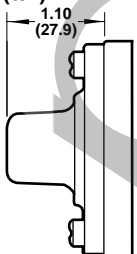

KC0 – END CAP

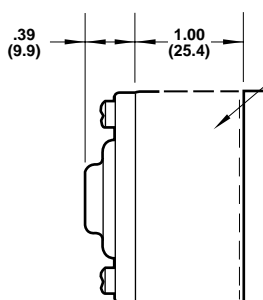

SPACER BLOCK – Used only with spring centered manual operators (KK2, KL2, KL7, KT2).

Nugget 200 Spool Valves

1/4", 3/8", or 1/2" Ports, Manual and Mechanical Actuated 3/2, 5/2, & 5/3 Inline and Stacking Valves

Manual Operators

Dimensions in inches (mm)

KB0/KB5 – PALM BUTTON

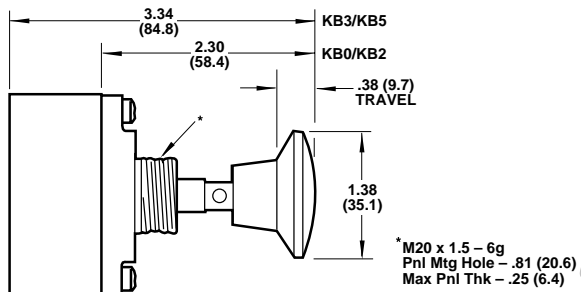

KK0/KK3 – KNOB

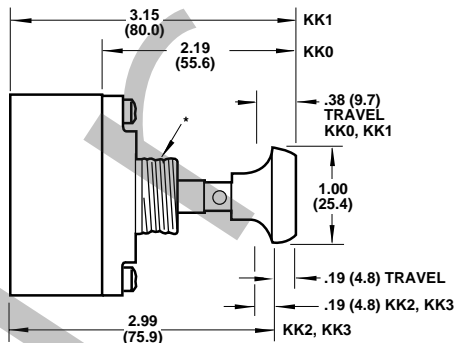

KL0/KL3 – LEVER

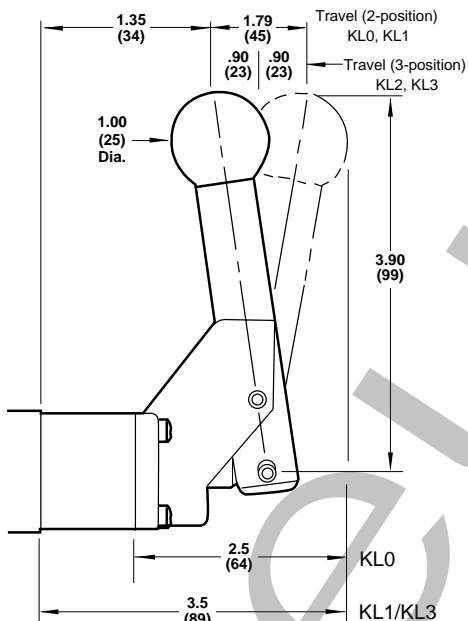

KL5/KL8 – LEVER

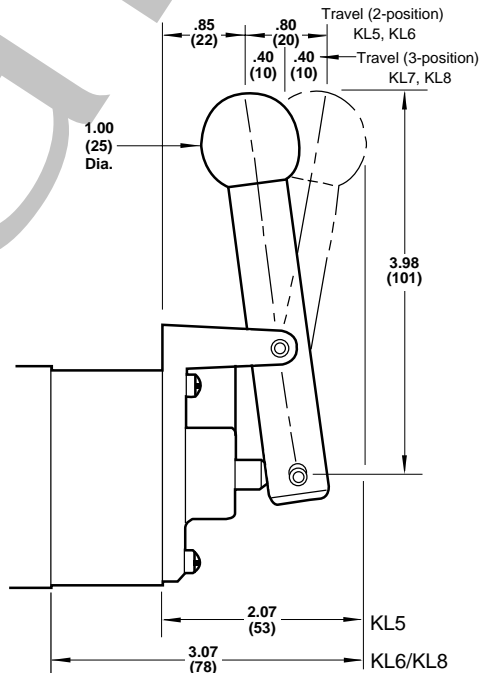

KT0/KT2 – TREADLE

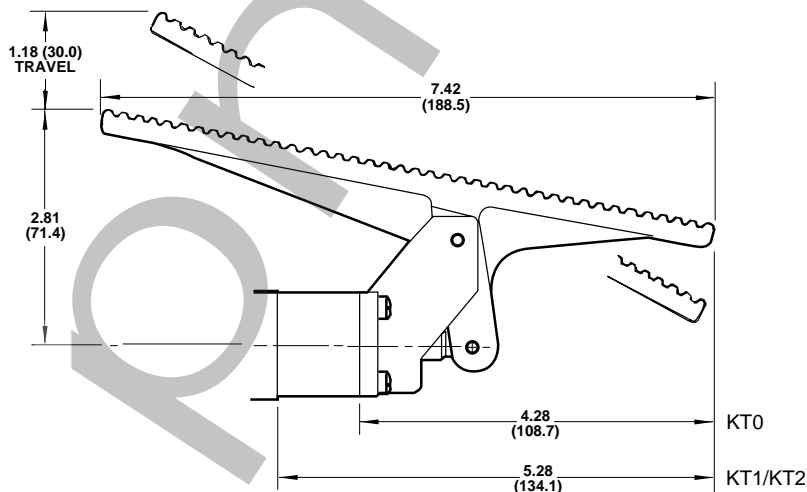

KF0 – FOOT PEDAL

