

ORDER  
ONLINE

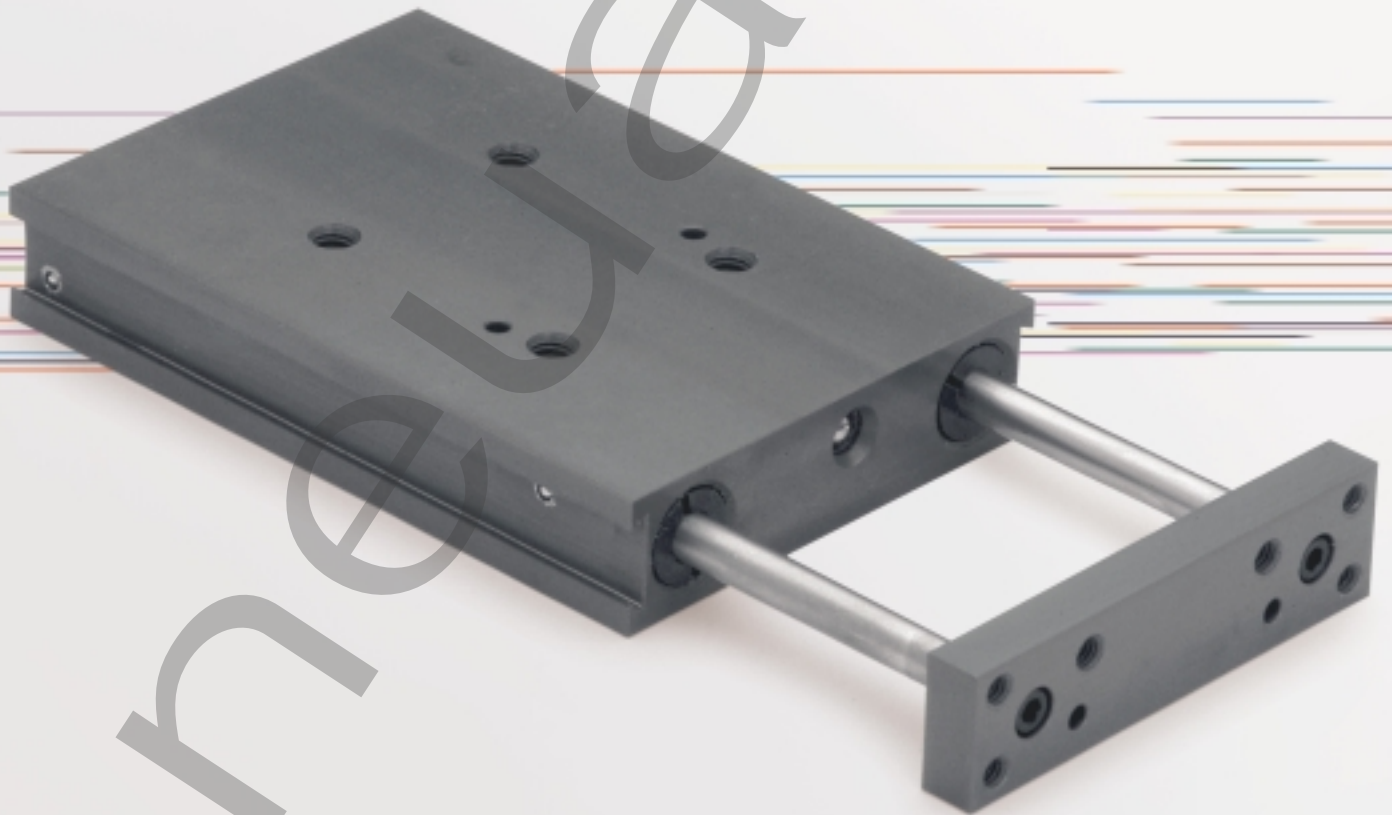

Slides



# ***B Series***

***Compact Linear Slide***

*We're everywhere you need us to be!*



## B Series

|                                    |     |
|------------------------------------|-----|
| Features and Benefits .....        | 3-6 |
| How To Order .....                 | 3   |
| Dimensions .....                   | 4   |
| Technical and Operating Data ..... | 5   |
|                                    | 6   |

Pneuhair



B Series

The “B” series design is compact and self-contained. Cylinder pistons are attached directly to each guide rod, conserving size without sacrificing output force. Guide rods are supported by specially designed guide bushings providing optimum support of dynamic loads. Guide bushings are manufactured from specially engineered materials designed to eliminate potential rod binding.

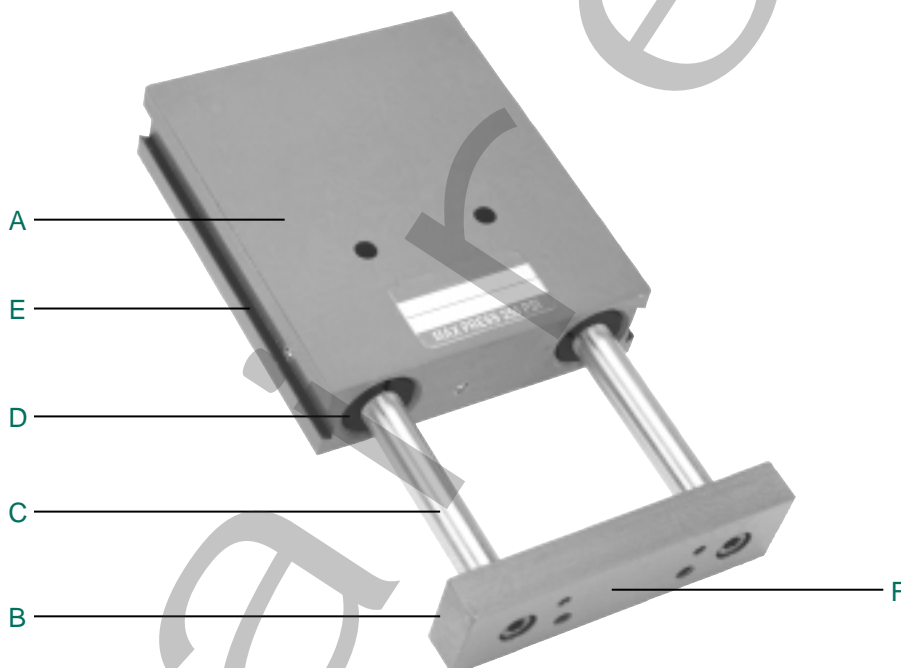

**A. Body:**

Hardcoat anodized aluminum ..... lightweight, durable, high strength to weight ratio  
 Teflon® coated..... inside and out, reduced friction, increased seal life  
 Easy access mounting..... holes drilled from top and tapped from bottom,  
 standard dowel locating holes for accurate mounting  
 Integrated sensing mount..... dovetail rail both sides to accept Numatics World Switch

**B. Tooling Plate:**

Hardcoat anodized aluminum ..... lightweight, durable  
 Easy access mounting..... holes drilled and tapped, dowel locating holes standard  
 NuMate™ mounting capability..... reduced cost, eliminates adapters and transition plates

**C. Guide Shafts:**

Hardened steel to Rc60-65..... low friction, long life  
 Pilot mounted to tooling plate ..... maximum rigidity

**D. Bearings:**

Special engineered material ..... low friction, long life  
 Maximum rigidity ..... superior rod diameter to bearing length ratio

**E. Position Sensing:**

Easy access position sensor mounting ..... integrated dovetail mounting, twin piston magnets-standard

**F. NuMate™ Mounting:**

Direct mount mounting system ..... patented mounting system eliminates requirement  
 Patent No. 5,560,281 ..... for adapters and transition plates



B Series

How to Order

**B 04 1 E 1 H 6 D X**

**Bore Sizes**

- 04 = 0.437 Inch
- 06 = 0.625 Inch
- 08 = 0.875 Inch

**Standard Stroke**

- 0 = 0"
- 1 = 1"
- 2 = 2"
- 3 = 3"
- 4 = 4" Maximum Stroke

**Fractional Stroke**

- A = 0 Inch
- E = 1/2 Inch

**Seal Option**

- 1 = Buna
- 2 = Viton

**Options**

- X = No Options
  - T = Top Surface Ports
  - B = Bottom Surface Ports
- For top port option, see page 5.

**Sensing Position**

- A = Single Position Extend
- B = Single Position Retract
- C = Extend and Retract
- D = No Sensing

**Sensing Type**

- Standard Cord Set
- 1 = Hall Effect - PNP (sourcing)
  - 2 = Hall Effect - NPN (sinking)
  - 3 = Reed Switch
  - 6 = No Sensing
- Quick Disconnect Cord Set
- Z = Hall Effect - PNP (sourcing)
  - Y = Hall Effect - NPN (sinking)
  - X = Reed Switch

**Guide Shaft Material**

- H = Hardened Steel
- S = Stainless Steel

Example order:

Part Number: B041E1H6DX\*

Part Description: 7/16" diameter twin bore linear slide, 1.5" stroke, buna seals, 1/4" hardened steel guide shafts, no switches, no special options.

When ordering additional accessories:

| SWITCH DESCRIPTION         | STANDARD PART NO. | QUICK DISCONNECT PART NO. |
|----------------------------|-------------------|---------------------------|
| Hall Effect-PNP (Sourcing) | HPNPS31           | HPNPQ31                   |
| Hall Effect-NPN (Sinking)  | HNPNS32           | HNPNQ32                   |
| Reed Switch                | RSS02             | RSQ02                     |
| 90° 5 meter cable          | -                 | PXC 90                    |
| Straight 5 meter cable     | -                 | PXC ST                    |

| SERIES | BUNA-N SEAL KIT | VITON SEAL KIT |
|--------|-----------------|----------------|
| B04    | BSKB-04         | BSKV-04        |
| B06    | BSKB-06         | BSKV-06        |
| B08    | BSKB-08         | BSKV-08        |



B Series



B Series Dimensions

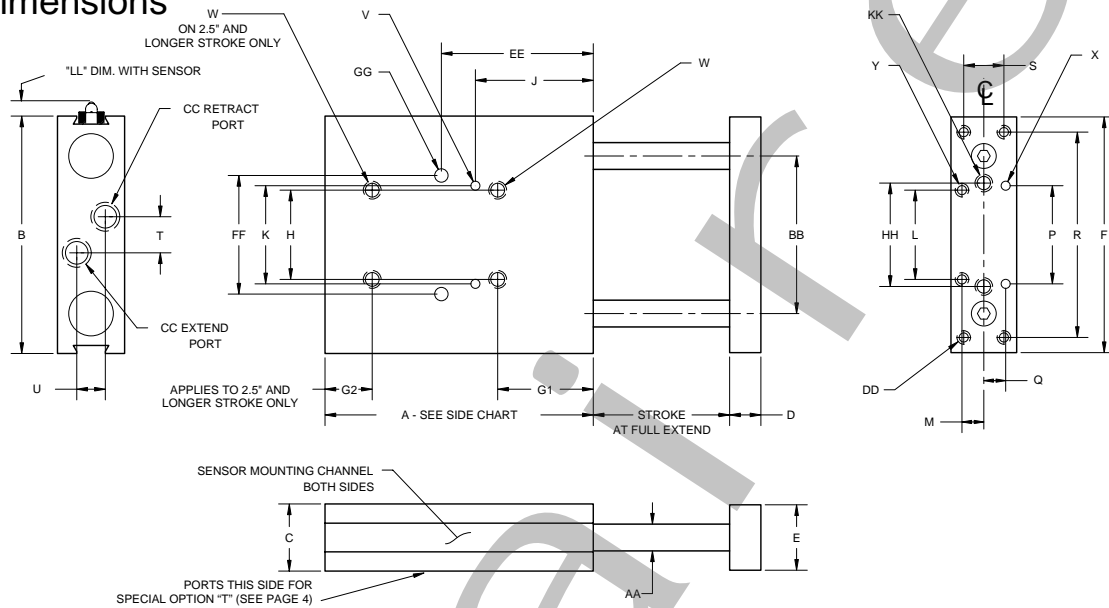

| STROKE      | Dim | B04    |       | B06    |       | B08    |       |
|-------------|-----|--------|-------|--------|-------|--------|-------|
|             |     | Inches | mm    | Inches | mm    | Inches | mm    |
| 1/2" & 1"   | A   | 2.28   | 57.9  | 2.85   | 72.4  | 3.27   | 83.1  |
| 1-1/2" & 2" | A   | 3.28   | 83.3  | 3.85   | 97.8  | 4.27   | 108.5 |
| 2-1/2" & 3" | A   | 4.28   | 108.7 | 4.85   | 123.2 | 5.27   | 133.9 |
| 3-1/2" & 4" | A   | 5.28   | 134.1 | 5.85   | 148.6 | 6.27   | 159.3 |

|    | B04                      |                    | B06                      |                    | B08  |                    |
|----|--------------------------|--------------------|--------------------------|--------------------|--|--------------------|
|    | Inches                   | mm                 | Inches                   | mm                 | Inches   | mm                 |
| B  | 2.86                     | 72.6               | 3.33                     | 84.6               | 3.82   | 97.0               |
| C  | 0.75                     | 19.1               | 0.94                     | 23.9               | 1.23   | 31.2               |
| D  | 0.31                     | 7.9                | 0.44                     | 11.2               | 0.60   | 15.2               |
| E  | 0.74                     | 18.8               | 0.92                     | 23.4               | 1.20   | 30.5               |
| F  | 2.85                     | 72.4               | 3.30                     | 83.8               | 3.79   | 96.3               |
| G1 | 1.30                     | 33.0               | 1.34                     | 34.0               | 1.76   | 44.7               |
| G2 | 1.48                     | 37.6               | 1.01                     | 25.7               | 1.51   | 38.4               |
| H  | 1.25                     | 31.8               | 1.25                     | 31.8               | 1.25   | 31.8               |
| J  | 1.61                     | 40.9               | 1.65                     | 41.9               | 2.08   | 52.8               |
| K  | 1.374/1.376              | 34.9/34.95         | 1.374/1.376              | 34.9/34.95         | 1.374/1.376  | 34.9/34.95         |
| L  | 1.25                     | 31.8               | 1.25                     | 31.8               | 1.25   | 31.8               |
| M  | 0.16                     | 4.1                | 0.16                     | 4.1                | 0.31   | 7.9                |
| P  | 1.374/1.376              | 34.9/34.95         | 1.374/1.376              | 34.9/34.95         | 1.811/1.812  | 46.0/46.1          |
| Q  | 0.16                     | 4.1                | 0.16                     | 4.1                | 0.38   | 9.7                |
| R  | 2.50                     | 63.5               | 2.88                     | 73.2               | 3.25   | 82.6               |
| S  | 0.44                     | 11.2               | 0.56                     | 14.2               | 0.75   | 19.1               |
| T  | 0.25                     | 6.4                | 0.51                     | 13.0               | 0.51   | 13.0               |
| U  | 0.35                     | 8.9                | 0.40                     | 10.2               | 0.40   | 10.2               |
| V  | 0.1250/0.1255 x 0.200 DP | 3.18/3.19 x 5.1 DP | 0.1250/0.1255 x 0.200 DP | 3.18/3.19 x 5.1 DP | 0.1250/0.1255 x 0.200 DP                                     | 3.18/3.19 x 5.1 DP |
| W  | 1/4-20 THRU              | —                  | 1/4-20 THRU              | —                  | 1/4-20 THRU  | —                  |
| X  | 0.1250/0.1255 THRU       | 3.18/3.19 THRU     | 0.1250/0.1255 THRU       | 3.18/3.19 THRU     | 0.1875/0.1880 THRU   | 4.76/4.77 THRU     |
| Y  | #10-32 THRU              | —                  | #10-32 THRU              | —                  | #10-32 THRU  | —                  |
| AA | .250 NOM.                | 6.35               | .375 NOM.                | 9.53               | .500 NOM.  | 12.7               |
| BB | 2.00                     | 50.8               | 2.21                     | 56.1               | 2.46   | 62.5               |
| CC | #10-32                   | —                  | 1/8 NPTF                 | —                  | 1/8 NPTF   | —                  |
| DD | #8-32 THRU               | —                  | #10-32 THRU              | —                  | 1/4-20 THRU  | —                  |
| EE | —                        | —                  | —                        | —                  | 2.44   | 62.0               |
| FF | —                        | —                  | —                        | —                  | 1.811/1.813  | 46.0/46.1          |
| GG | —                        | —                  | —                        | —                  | 0.1875/0.1880 x 0.120 DP                                     | 4.76/4.78 x 4.8 DP |
| HH | —                        | —                  | —                        | —                  | 1.50   | 38.1               |
| KK | —                        | —                  | —                        | —                  | 1/4-20 THRU, C'BORE<br>FOR #10-32 SHCS<br>FROM OPPOSITE SIDE | —                  |
| LL | .29                      | (7.3)              | .30                      | (7.6)              | .30  | (7.6)              |



## B Series

### Unit Weight Table

|                              | B04  | B06  | B08  |
|------------------------------|------|------|------|
| Unit Weight (lbs)            | 0.30 | 0.52 | 1.08 |
| Adder/Full Inch Stroke (lbs) | 0.19 | 0.28 | 0.58 |

Always round up to the next full inch stroke for 1/2 inch stroke increments.

Example: B062E1H6DX       $0.52 + (3 \times 0.28) = 1.36$  lbs.

### Unit Output Force Table

|                     | B04  | B06  | B08  |
|---------------------|------|------|------|
| Extend Force (lbs)  | 0.30 | 0.61 | 1.20 |
| Retract Force (lbs) | 0.20 | 0.39 | 0.81 |

Multiply force factor by input pressure in psi.

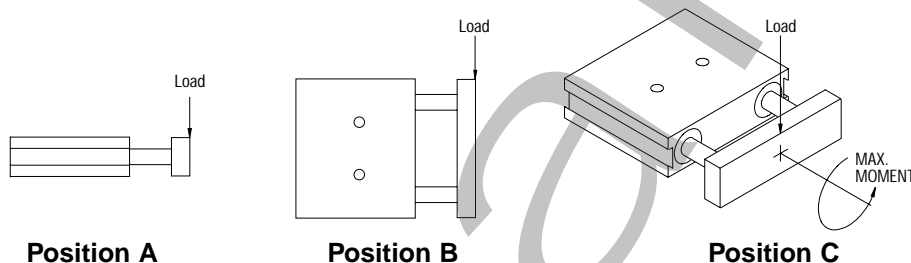

### Maximum Dynamic Load and Deflection Ratings

| STROKE | B04                   |                            |                     | B06                   |                            |                     | B08                   |                            |                     |
|--------|-----------------------|----------------------------|---------------------|-----------------------|----------------------------|---------------------|-----------------------|----------------------------|---------------------|
|        | POS A&B<br>LOAD (LBS) | POS A&B<br>DEFLECTION (IN) | POS C<br>MAX MOMENT | POS A&B<br>LOAD (LBS) | POS A&B<br>DEFLECTION (IN) | POS C<br>MAX MOMENT | POS A&B<br>LOAD (LBS) | POS A&B<br>DEFLECTION (IN) | POS C<br>MAX MOMENT |
| 1      | 4.0                   | 0.0005                     | 4.0 inlb            | 8.0                   | 0.0002                     | 8.0 inlb            | 13.0                  | 0.0001                     | 13.0 inlb           |
| 2      | 2.0                   | 0.0011                     | 2.0 inlb            | 4.0                   | 0.0004                     | 4.0 inlb            | 6.5                   | 0.0002                     | 6.5 inlb            |
| 3      | 1.5                   | 0.0018                     | 1.5 inlb            | 2.6                   | 0.0006                     | 2.6 inlb            | 4.5                   | 0.0004                     | 4.5 inlb            |
| 4      | 1.0                   | 0.0025                     | 1.0 inlb            | 2.0                   | 0.0010                     | 2.0 inlb            | 3.5                   | 0.0006                     | 3.5 inlb            |

For static loads multiply dynamic by 1.3.

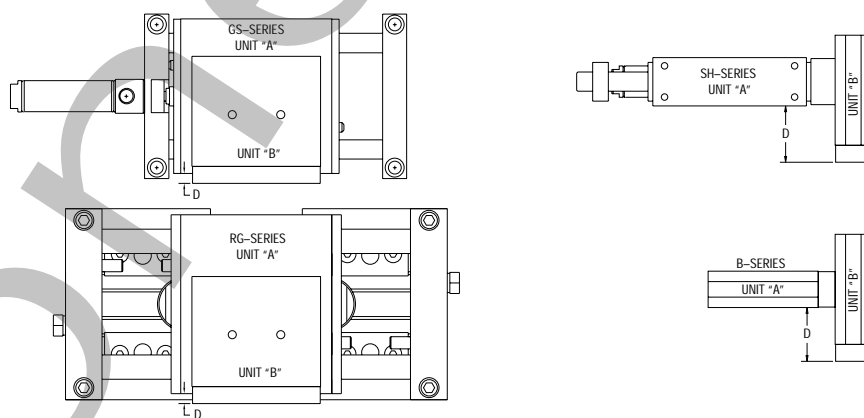

| UNIT "B" | UNIT "A" ("D" = DIMENSION IN INCHES) |       |       |       |               |       |       |
|----------|--------------------------------------|-------|-------|-------|---------------|-------|-------|
|          | B04                                  | B06   | B08   | GS075 | GS106 & RG25B | SH056 | SH075 |
| B04      | 1.403                                | 1.564 | 2.149 | 0.094 | 0.239         | 1.139 | 1.329 |
| B06      | 1.310                                | 1.472 | 1.486 | 0.256 | 0.401         | 1.300 | 1.491 |
| B08      | 2.149                                | 2.057 | 2.071 | 0.841 | 0.986         | 1.886 | 2.076 |