



# Accessories



## ***FRL Accessories and Options***

*We're everywhere you need us to be!*



## FRL Accessories and Options

FRL Accessories and Options .....	3-18
Digital Pressure Sensor/Digital Vacuum Sensor .....	3-6
PS180 Pressure Switches .....	7
PS181 Economy Series Pressure Switches .....	8
PS182 Pressure Switches .....	9
Reclassifiers .....	10
Tank Drain Trap .....	11
Electronic Drain Valves .....	12
Inline Disposable Filter .....	13
Miniature Manifold Regulator .....	14-15
Oxygen Concentrator Regulator .....	16-17
Gauges .....	18

Pneumatics



## Numatics FRL Accessories and Options

### Digital Pressure Sensor/Digital Vacuum Sensor



DPS-180N (left) and DPSG180P (right) pictured



#### Application

Numatics DPS and DVS is a line of digital pressure sensors designed for extremely accurate indication that proper system pressure is being achieved. Available for either vacuum (DVS model) or pressure (DPS model) applications, its highly visible LED display makes it easy to read in either dark or light areas. Other features include quick response (within 2.5ms or less), high repeatability (within 0.2% full scale 1 digit), easy pushbutton setup, and four output process modes which enable versatile pressure level control.

Applications include securing chip-component carriages on a suction hand, controlling of clamp forces, controlling the edge of winding film, verification of frame uniformity, and many more.

#### SPECIFICATIONS

Pressure scale:	Gauge pressure	
Rated pressure range:	Pressure sensor: 0 - 145 PSI; Vacuum sensor: 0 - 14.7 PSI	
Setting pressure range:	Pressure sensor: -0.050 to 1.000 MPa; Vacuum sensor: 5.1 to -101.3 kPa	
Pressure resistance:	Pressure sensor: 1.47 MPa; Vacuum sensor: 490 kPa	
Applicable fluid:	Non-corrosive gas	
Selectable units:	Pressure sensor: kgf/cm <sup>2</sup> , bar, PSI; Vacuum sensor: kgf/cm <sup>2</sup> , bar, PSI, mmHg, InchHg	
Supply voltage:	12 to 24V DC (+10%/-15%) Ripple P-P 10% or less	
Current consumption:	50mA or less	
Comparative output:	NPN open-collector transistor	PNP open-collector transistor
	• Max. sink current: 100mA	• Max. source current: 100mA
	• Applied voltage: 30V DC or less	• Applied voltage: 30V DC or less
	• Residual voltage: 1V or less (@ 100mA sink current)	• Residual voltage: 2V or less (@ 100mA source current)
	0.4V or less (@ 16mA sink current)	
Utilization category:	DC-12 or DC-13	
Output pressure mode:	Selectable with key operation - hysteresis mode, window comparator mode, dual output mode, or automatic setting mode	
Hysteresis:	1 digit (2 digits when using PSI unit, variable when using hysteresis mode)	
Repeatability:	Within ± 0.2% F.S. ± 1 digit	
Response time:	2.5 ms or less	
Short circuit protection:	Incorporated	
Analog voltage output:	Output voltage: 1 to 5V (with rated pressure gauge) Zero-point: Within 1V ± 5%F.S. Span: Within 4V ± 5% F.S. Linearity: Within ± 1% F.S. Output impedance: App. 1kW	
Display:	Red LED display, 3 1/2 digits (sampling cycle: 4 times/sec.)	
Pressure display range:	Pressure sensor: -0.050 to 1.000 MPa; Vacuum sensor: 5.1 to -101.3 kPa	
Analog bar display:	LED-bar step indication every app. 10% F.S.	
Operation indicator		
comparative output 1:	Orange LED (lights up when the comparative output 1 is activated)	
comparative output 2:	Green LED (lights up when the comparative output 2 is activated)	
Environmental resistance		
Pollution degree:	3 (Industrial environment)	
Protection:	IP40 (IEC)	
Ambient temperature:	14° to 122°F (-10° to +50° C) (No dew condensation or icing), Storage: 14° to 140°F (-10° to +60°C)	
Ambient humidity:	35-85% RH, Storage: 35-8% RH	
EMC:	Emmision: EN50081-2, Immunity: EN50082-2	
Voltage withstandability:	1,000V AC for 1 minute between all terminals connected and enclosure	
Insulation resistivity:	50kW or more at 500V DC Megger between all terminals connected and enclosure	
Vibration proof:	10-150Hz freq., 0.03 inch (0.75mm) amplitude, and X,Y,& Z directions each for 2 hours (unenergized)	
Shock proof:	100m/s <sup>2</sup> acceleration (app. 10G), and X,Y,& Z directions each for three times (unenergized)	
Temperature characteristic:	Within ±1% F.S. of detection pressure at 68°F (20°C) in 14°-122°F (-10°-+50°C) temp. range	
Material:	Front case: ABS; rear case: PPS (containing glass fiber); display surface: acrylic; press. port attachment: die-cast zinc alloy	
Cable:	Oil-resistant cabtyre cable 6.5 feet (2m) long w/ 5 0.15mm <sup>2</sup> conductors	
Cable extension:	Max. extension is 328 feet (100m) overall with an equilvant cable with conductors 0.3 mm <sup>2</sup> or more	
Weight:	NPT/BSPT: 3.35 oz (95g); BSPP: 4.23 oz (120g)	

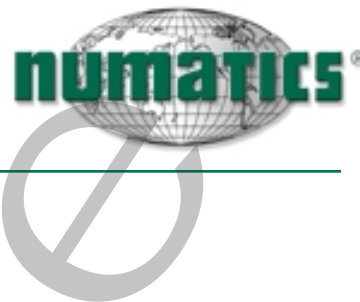

## Digital Pressure Sensor/Digital Vacuum Sensor – Model Selection

### 2 Meter Pigtail Cable

PRESSURE SENSOR (0-145PSI;0-1.000MPa)		VACUUM SENSOR (0 to -14.5PSI;0 to -101.3 kPa)	
MODEL	DESCRIPTION	MODEL	DESCRIPTION
DPS-180N	NPN (sinking) 1/8 NPTF Base	DVS-180N	NPN (sinking) 1/8 NPTF Base
DPS-180P	PNP (sourcing) 1/8 NPTF Base	DVS-180P	PNP (sourcing) 1/8 NPTF Base
DPSG180N	NPN (sinking) 1/8 BSPP Base	DVSG180N	NPN (sinking) 1/8 BSPP Base
DPSG180P	PNP (sourcing) 1/8 BSPP Base	DVSG180P	PNP (sourcing) 1/8 BSPP Base
DPSR180N	NPN (sinking) 1/8 BSPT Base	DVSR180N	NPN (sinking) 1/8 BSPT Base
DPSR180P	PNP (sourcing) 1/8 BSPT Base	DVSR180P	PNP (sourcing) 1/8 BSPT Base

### 8 Inch Lead, 8 mm Pico Connector

PRESSURE SENSOR (0-145PSI;0-1.000MPa)		VACUUM SENSOR (0 to -14.5PSI;0 to -101.3 kPa)	
MODEL	DESCRIPTION	MODEL	DESCRIPTION
DPS-180N-1	NPN (sinking) 1/8 NPTF Base	DVS-180N-1	NPN (sinking) 1/8 NPTF Base
DPS-180P-1	PNP (sourcing) 1/8 NPTF Base	DVS-180P-1	PNP (sourcing) 1/8 NPTF Base
DPSG180N-1	NPN (sinking) 1/8 BSPP Base	DVSG180N-1	NPN (sinking) 1/8 BSPP Base
DPSG180P-1	PNP (sourcing) 1/8 BSPP Base	DVSG180P-1	PNP (sourcing) 1/8 BSPP Base
DPSR180N-1	NPN (sinking) 1/8 BSPT Base	DVSR180N-1	NPN (sinking) 1/8 BSPT Base
DPSR180P-1	PNP (sourcing) 1/8 BSPT Base	DVSR180P-1	PNP (sourcing) 1/8 BSPT Base

### 8 Inch Lead, 12 mm Micro Connector

PRESSURE SENSOR (0-145PSI;0-1.000MPa)		VACUUM SENSOR (0 to -14.5PSI;0 to -101.3 kPa)	
MODEL	DESCRIPTION	MODEL	DESCRIPTION
DPS-180N-2	NPN (sinking) 1/8 NPTF Base	DVS-180N-2	NPN (sinking) 1/8 NPTF Base
DPS-180P-2	PNP (sourcing) 1/8 NPTF Base	DVS-180P-2	PNP (sourcing) 1/8 NPTF Base
DPSG180N-2	NPN (sinking) 1/8 BSPP Base	DVSG180N-2	NPN (sinking) 1/8 BSPP Base
DPSG180P-2	PNP (sourcing) 1/8 BSPP Base	DVSG180P-2	PNP (sourcing) 1/8 BSPP Base
DPSR180N-2	NPN (sinking) 1/8 BSPT Base	DVSR180N-2	NPN (sinking) 1/8 BSPT Base
DPSR180P-2	PNP (sourcing) 1/8 BSPT Base	DVSR180P-2	PNP (sourcing) 1/8 BSPT Base

Note: See accessories on page 5-6.

### Female Single Ended Cordset

CONNECTOR TYPE	CONNECTOR STYLE	CONNECTOR LENGTH	MODEL NUMBER
M8 Pico	Straight	2 Meters	DPS-08-02-ST
M8 Pico	Straight	5 Meters	DPS-08-05-ST
M12 Micro	Straight	2 Meters	DPS-12-02-ST
M12 Micro	Straight	5 Meters	DPS-12-05-ST



Numatics FRL  
Accessories and Options

Digital Pressure Sensor/Digital Vacuum Sensor Dimensions

NPTF/BSPT model

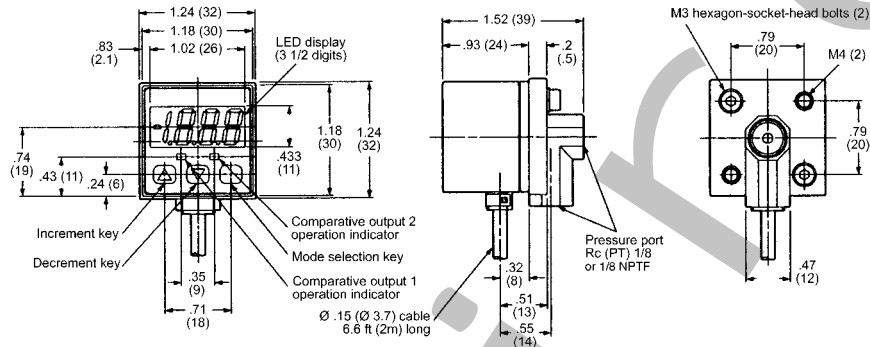

BSPP model

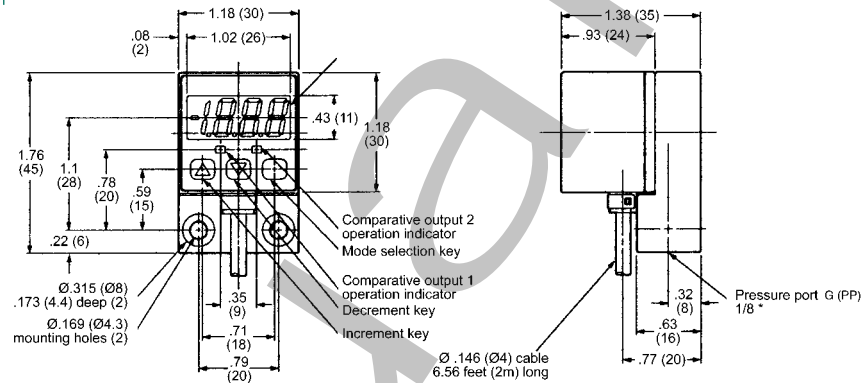

Mounting Bracket\* (UZU811)

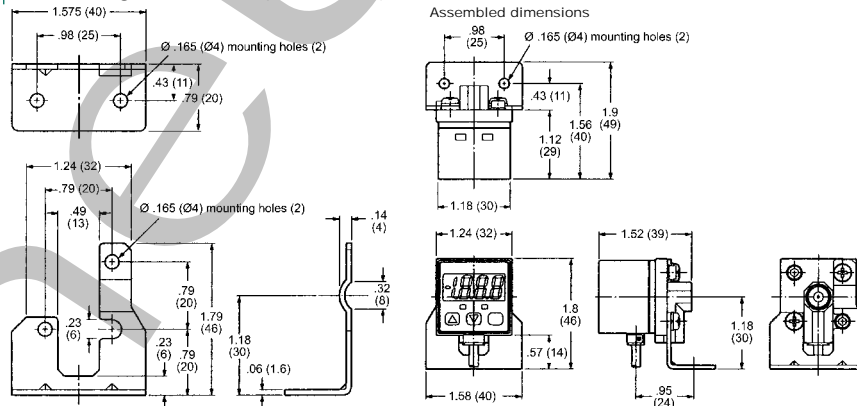

Panel Mounting Bracket with Protective Cover\*

(Panel mounting bracket: UZU812; Front protective cover: UZU813)

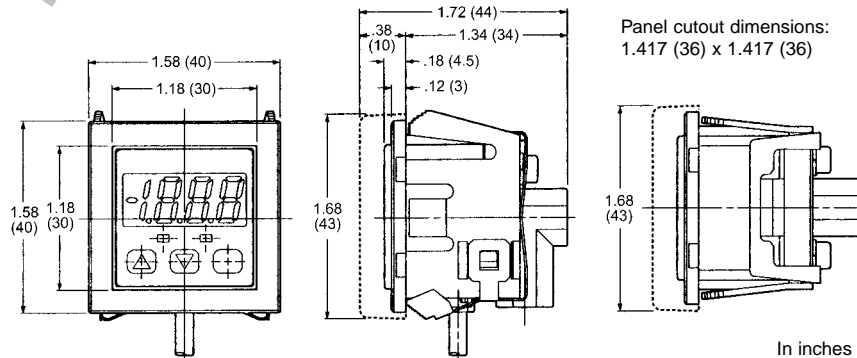

In inches (millimeters in parenthesis)



## Numatics FRL Accessories and Options



### Digital Pressure Sensor/Digital Vacuum Sensor — Options (NPTF & BSPT models only)

#### Panel Mounting Bracket and Front Protective Cover

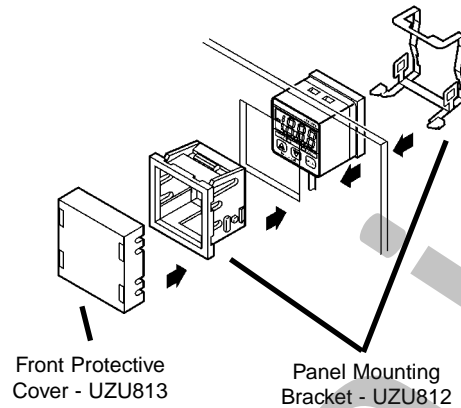

NOTE: Front protective cover used with panel mounting bracket cannot be used alone.

#### Sensor Mounting Bracket

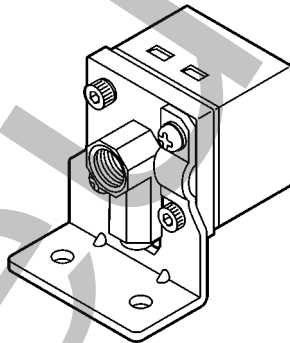

Part # UZU811  
Two M4 pan head screws and two spring washers included.



Numatics FRL  
Accessories and Options



PS180 Pressure Switches

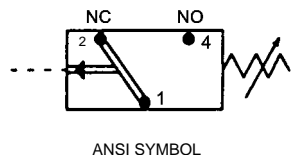

Application

Numatics PS180 is a line of pressure switches designed for accurate indication that proper system pressure is being achieved. Available in 1/8 or 1/4 threads, it is easily incorporated into an air system using a FLEXIBLOK® diverter plate of other manifold.

Featuring a rugged housing made from zinc coated steel, the PS180 is designed for industrial multi-million cycle life applications. The four pin connector plug is included and contains a key way preventing accidental misconnection. Pressure adjustment is tamper resistant, hindering unauthorized changes. It can be wired in either normally open or normally closed configurations and includes a case ground pin.

Specifications

- Contact Rating: 4A @ 250 V AC
- Protection: IP 65, terminals IP00
- Maximum Operation: 200/min
- Temperature Range: 0° F to 190° F (-15° C to 85° C)
- Maximum Pressure: 300 PSI (20 bar)
- Maximum Voltage: 250 V AC (200 DC)
- Hysteresis Adjustment: 15%
- Connector Material: polyamid
- Diaphragm Material: Buna N
- Housing Material: zinc plated steel

Dimensions in inches (millimeters in parenthesis)

NPTF Thread Dimensions

MODEL	A	B	C
PS180BAN01	2.5 (64)	1.0 (27)	3.1 (79)
PS180CAN01	2.5 (64)	1.0 (27)	3.1 (79)
PS180BAN02	2.5 (64)	1.0 (27)	3.1 (79)
PS180CAN02	2.5 (64)	1.0 (27)	3.1 (79)

BSPP Thread Dimensions

MODEL	A	B	C
PS180BAG01*	2.5 (64)	1.0 (27)	3.1 (79)
PS180CAG01*	2.5 (64)	1.0 (27)	3.1 (79)
PS180BAG02	2.3 (58)	1.0 (27)	2.9 (74)
PS180CAG02	2.3 (58)	1.0 (27)	2.9 (74)

\* = consists of an NPTF pressure switch with an NPTF to BSPP adapter (part number N2GC; adds app. 13/16" to overall height)

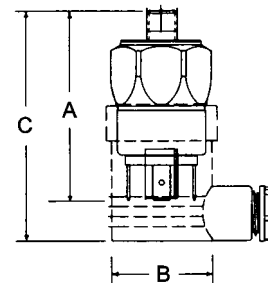

NPTF Thread Model Selection

NPTF	MODEL	PSIG (BAR)
1/8	PS180BAN01	4-20 (.3-1.5)
1/8	PS180CAN01	14-150 (1-10)
1/4	PS180BAN02	4-20 (.3-1.5)
1/4	PS180CAN02	14-150 (1-10)

BSPP Thread Model Selection

BSPP	MODEL	PSIG (BAR)
1/8	PS180BAG01	4-20 (.3-1.5)
1/8	PS180CAG01	14-150 (1-10)
1/4	PS180BAG02	4-20 (.3-1.5)
1/4	PS180CAG02	14-150 (1-10)

Use "G" suffix for gold plated terminals (for applications below 50 mA), i.e. PS180BAN02G



## Numatics FRL Accessories and Options



### PS181 Economy Series Pressure Switches

#### Application

Numatics PS181 is the most economical of the Numatics Pressure Switch line. Available in 1/8 or 1/4 NPT and BSPP threads, it is easily incorporated into an air system using a FlexiBlok diverter plate or diverter block.

Unlike the PS180 Switch, which uses a plug mount for the electrical connection, the PS181 directly connects to the body mounted terminals. Pressure adjustment is tamper resistant, hindering unauthorized changes. It can be wired in either a normally open or normally closed configuration.

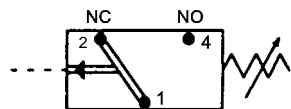

ANSI SYMBOL

#### Specifications

Hysteresis Adjustment	15%
Pressure Ranges:	4 - 20, 14-150 psi
Max Pressure:	300 psi
Set Point Tolerance:	+/- 1 Psi or 5%
*Contact Rating:	4A @ 250 V AC
Diaphragm Material:	Buna N
Max Operating Cycles:	200/min
Temperature Range:	0 to 190 F (-15 to 85 C)
Maximum Voltage:	250 V AC
Sealing/Protection:	IP 65, terminals IP 00
Housing Material:	Zinc Plated Steel
Connector Material:	Polyamide

#### Dimensions in inches (millimeters in parenthesis)

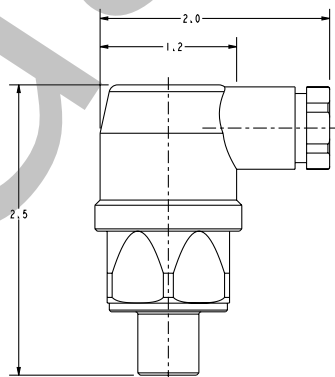

#### NPTF Thread Model Selection

NPTF	MODEL	PSIG (BAR)
1/8	PS181BAN01	4-20 (0.3-1.5)
1/8	PS181CAN01	14-150 (1-10)
1/4	PS181BAN02	4-20 (0.3-1.5)
1/4	PS181CAN02	14-150 (1-10)

#### BSPP Thread Model Selection

BSPP	MODEL	PSIG (BAR)
1/8	PS181BAG01*	4-20 (0.3-1.5)
1/8	PS181CAG01*	14-150 (1-10)
1/4	PS181BAG02	4-20 (0.3-1.5)
1/4	PS181CAG02	14-150 (1-10)

\*Consists of an NPT pressure switch with an NPTF to BSPP Adapter (part number N2GC; adds app. 13/16" to overall height).





## Numatics FRL Accessories and Options

### PS182 Pressure Switches

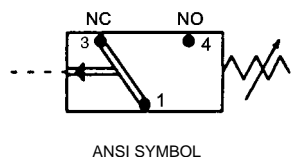

#### Application

Numatics PS182 is the most rugged of the Numatics Pressure Switches. Available in 1/8 or 1/4 NPT and BSPP threads, it is easily incorporated into an air system using a FlexiBlok diverter plate or diverter block. The unique 12 mm, micro connector makes it simple for electrical connection. The knurled knob with tamper resistant hex screw makes it the easiest pressure adjustment on the market. It can be wired in either a normally open or normally closed configuration.

#### Specifications

Hysteresis Adjustment	10%
Pressure Ranges:	2-10, 6-30, 20-130
Max Pressure:	600 psi
Set Point Tolerance:	+/- 1 Psi or 5%
*Contact Rating:	4A
Diaphragm Material:	Buna N
Max Operating Cycles:	200/min
Temperature Range:	-40 to 250 F (-40 to 121 C)
Voltage Range:	12 V DC to 250 V AC
Sealing/Protection:	IP 65
Housing Material:	Brass
Electrical Connection:	3-Pin Micro (12 mm)

\*Comes standard with gold plated contacts.

#### Dimensions in inches (millimeters in parenthesis)

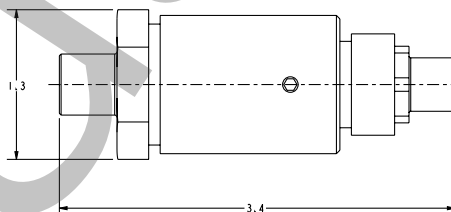

#### NPTF Thread Model Selection

NPTF	MODEL	PSIG (BAR)
1/8 NPT	PS182AAN01	2-10 (0.14-0.69)
1/8 NPT	PS182BAN01	6-30 (0.40-2.07)
1/8 NPT	PS182CAN01	20-130 (1.38-8.96)
1/4 NPT	PS182AAN02	2-10 (0.14-0.69)
1/4 NPT	PS182BAN02	6-30 (0.40-2.07)
1/4 NPT	PS182CAN02	20-130 (1.38-8.96)

#### BSPP Thread Model Selection

BSPP	MODEL	PSIG (BAR)
1/8 BSPP	PS182AAG01	2-10 (0.14-0.69)
1/8 BSPP	PS182BAG01	6-30 (0.40-2.07)
1/8 BSPP	PS182CAG01	20-130 (1.38-8.96)
1/4 BSPP	PS182AAG02	2-10 (0.14-0.69)
1/4 BSPP	PS182BAG02	6-30 (0.40-2.07)
1/4 BSPP	PS182CAG02	20-130 (1.38-8.96)

#### Female Single Ended Cordset

CONNECTOR TYPE	CONNECTOR LENGTH	MODEL NUMBER
90° Elbow	5 Meters	PS182-5-90
Straight	5 Meters	PS182-5-ST



## Numatics FRL Accessories and Options

### Reclassifiers



H40-08 pictured

#### Application

The Numatics Reclassifier is an exhaust coalescing filter/silencer. Its design removes oil mist and reduces noise from exhaust ports on pneumatic air valves, cylinders, and air control systems at extremely high flow rates.

The Numatics Reclassifier can be mounted to exhaust ports on any valve or manifold using a common exhaust base or by combining exhaust ports. Mounting it vertically fully utilizes the oil-catching sump surrounding the filter element and provides easy draining.

#### Features

- 99% oil removal efficiencies
- 25 dBA noise reduction
- high exhaust flow rates
- low differential back pressures
- top performer in automated paint systems
- 1 micron filtration
- manual or continuous drain option
- metric threads available

#### Specifications

Maximum temperature: 125° F (52° C) CV rating (30 Series): 6  
Maximum pressure: 100 PSIG (7 bar) CV rating (40 Series): 10

#### Air Flow vs. Back Pressure

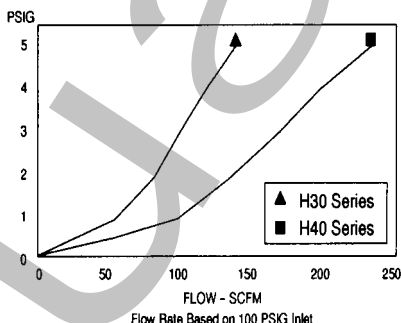

#### Air Flow vs. Sound Level

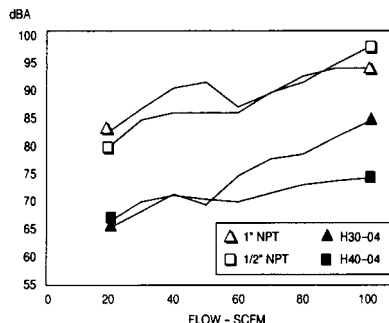

### Reclassifiers

#### > Element Replacement Kits

includes filter element only

kit #	description
EKF30H	30 Series, 1 micron coalescer
EKF40H	40 Series, 1 micron coalescer

#### > Bowl Replacement Kits

includes bowl and o-ring

kit #	description
BKF30	30 Series, polycarbonate bowl
BKF30C	30 Series, CircleVision™ bowl
BKF30M	30 Series, metal bowl
BKC40	40 Series, polycarbonate bowl

#### Dimensions

top dimensions = inches  
bottom dimensions (in parenthesis) = millimeters

MODEL	A	B
H30-04	2.5 (64)	7 (178)
H30-06	2.5 (64)	7 (178)
H40-08	3.75 (95)	7.245 (184)
H40-10	3.75 (95)	7.245 (184)

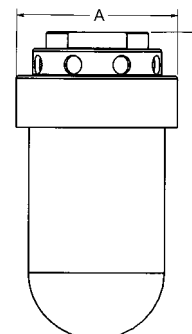

### How to Order

**H 30 - 04 M**

#### Threads

- = NPTF
- G = G Tap (BSPP)

#### Options

- C = CircleVision™ Sight Bowl
- M = Metal Bowl

#### Port Size

- 04 = 1/2
- 06 = 3/4

**H 40 - 08**

#### Port Size

- 08 = 1
- 10 = 1-1/4

#### Threads

- = NPTF
- G = G Tap (BSPP)



Numatics FRL  
Accessories and Options



Tank Drain Trap



J30-06CH pictured

Application

The Numatics Heavy Duty Tank Drain Trap is designed to automatically expel condensed moisture and compressor carryover liquids with a float design from compressed air systems, without the use of electricity, whenever liquids accumulate.

Features

- CircleVision™ bowl allows 360° view
- Heavy duty drain prevents clogging
- Pushbutton manual override

Specifications

Maximum Pressure: 250 PSIG (17 bar)  
 Minimum Pressure: 30 PSIG (2 bar)  
 Bowl Capacity: 8.5 oz

Dimensions

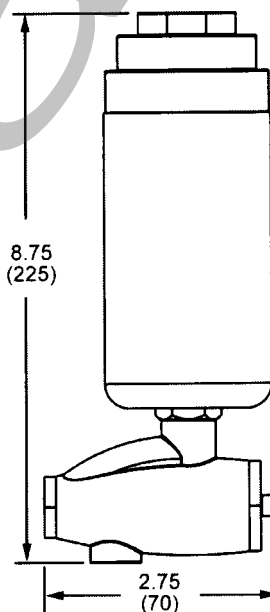

How to Order

J 30 - 04 C H

Port Size  
 04 = 1/2  
 06 = 3/4

Threads  
 - = NPTF  
 G = G Tap (BSPP)



Numatics FRL  
Accessories and Options



Electronic Drain Valves



EDV-04-110AC pictured

Application

Eliminate the manual draining of air lines with the EDV Series Electronic Drain Valve from Numatics. The EDV Series valve is designed to remove condensation from filters, receiver tanks, separators, drip legs, drain traps, and dryers in electronically controlled intervals. The EDV valve is available in 1/4, 3/8, and 1/2 sizes. The large orifice allows even the largest rust and pipe scale particles to be easily expelled. Standard model includes a 110 volt AC solenoid, 6 ft (2 m) power cord, and grounded plug. An EDV valve can be installed virtually anywhere.

Specifications

Valve

- Function: 2 way, NC, solenoid valve
- Valve Design: pilot operated diaphragm valve
- Port Sizes: 1/4, 3/8
- Orifice: 5/16" (8mm) 1.12 Cv 1/2" (12mm) 2.45 Cv
- Operating Pressure: 20-300 PSIG (1.3-20 bar)
- Solenoid: continuous duty
- Mounting: any position
- Body Material: brass

Timer

- Material: plastic polyamid
- Interval Timer: 1-45 sec
- 'On' Timer: .25-25 sec
- Voltage: 12-230 V AC/DC
- Frequency: 50/60 Hz
- Power Rating: 10 watt
- Enclosure: NEMA 4 / IP65
- Ambient Temp: 130° F (55° C)

Lights

- Left Indicator: power on
- Right Indicator: solenoid engineered

Dimensions

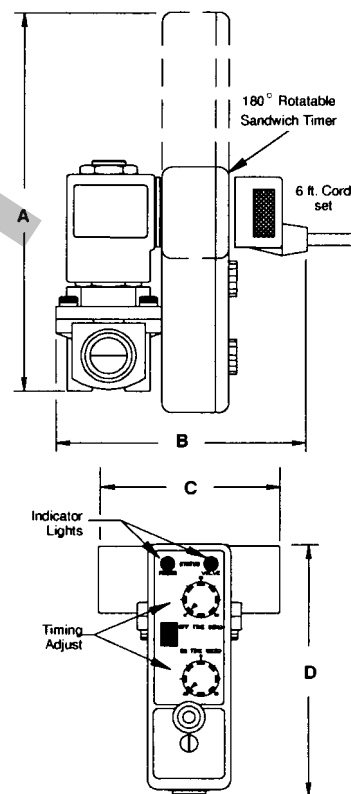

PORT SIZE	A	B	C	D
1/4,3/8	5.75 (146)	3.5 (89)	2.25 (57)	3.75 (95)
1/2	6.0 (152)	3.5 (89)	2.75 (70)	3.75 (95)

dimensions in inches (millimeters in parentheses)

How to Order

EDV - 04 - 110 AC

Model

EDV = Electronic Drain Valve

Threads

- = NPT  
B = BSPT

Port Size

02 = 1/4  
03 = 3/8  
04 = 1/2

Current

AC  
DC

Voltage

12  
24  
110  
230

Connector

- = 6 ft. (2 Meter) Power Cord  
(with grounded plug)  
X = Conduit Connector



Numatics FRL  
Accessories and Options



Inline Disposable Filter

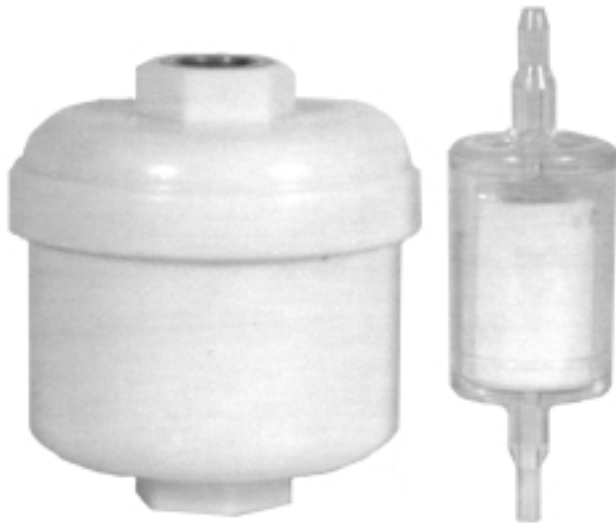

PHD-02 (left) and PLS-B (right) pictured

Application

The Inline Disposable Filter Combines a rugged compact housing with the low-cost advantages of a disposable filter. The Valox housing provides a long-life and trouble-free application and the disposable nature of the element makes disassembly and cleaning unnecessary. Available in HEPA or particulate grade media. The Mini-Inline Disposable Filter is equipped with dual barbs which fit most applications. It is perfectly suited for point-of-use filtration and monitoring of instruments, combining a rugged compact housing with a low-cost micro-pore filter. The element housing provides a durable and trouble-free application and its disposable nature makes disassembly and cleaning unnecessary. Available in two different particulate grades.

Features

Inline Disposable Filter

- Rugged Valox housing
- Brass inserts
- Inner support core which protects element from collapse
- Spin welded seal - no adhesives or chemicals
- Thermally bonded end caps on elements

Miniature Inline Disposable Filter

- Dual barb sizes (1/4 and 11/64)
- Rated burst pressure at 125 PSI
- Rated temperature at 125° F (52° C)
- Rugged polyurethane housing
- Compatible with many chemicals
- Depth-loading media provides long life

PH Series Dimensions (millimeters in parenthesis)

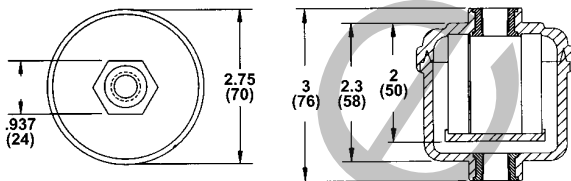

PL Series Dimensions (millimeters in parenthesis)

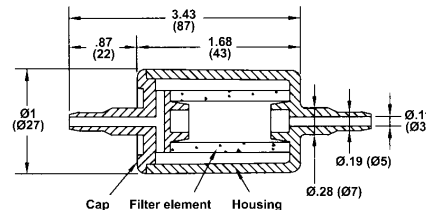

PH Series Flow Rates

MODEL	PSI	PSID	SCFM
PH*-O2*	30	0.5	20.5
		1.0	25.0
		1.5	32.0
PH*-O2*	50	0.5	22.0
		1.0	30.0
		1.5	41.0

PL Series Flow Rates

PRESSURE PSIG	PLS-B FLOW (SCFH) @ 1.5 PSID	PLU-B FLOW (SCFH) @ 1.5 PSID
1	33	43
20	61	71
40	80	90
60	95	105
80	110	120
100	134	144
120	172	182

How to Order

PH D - 02 B

Media  
B = 3 Micron Pleat  
D = HEPA

'Out' Port Option  
Blank = 1/4 NPTF  
B = 1/2 Hose Barbed

Threads  
- = NPT  
G = G Tap

PL S - B

Media  
S = 0.3 Micron  
U = 1 Micron



## Numatics FRL Accessories and Options

### Miniature Manifold Regulator MR02 Series



MR02R-01G pictured  
shown assembled and individually

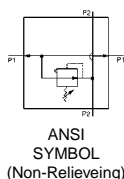
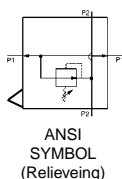

#### Application

The MR02 Series Miniature Manifold Regulator offers the flexibility necessary for many of today's applications. The MR02 Series allows several regulators to be chained together while maintaining a constant primary pressure to each regulator.

A system equipped with the Miniature Manifold Regulator can help reduce operation costs by reducing unnecessary downstream pressures and improve efficiencies by keeping them in one, convenient location for easy adjustment.

#### Features

- Can be installed as an individual or manifold unit
- Standard output pressure 0 -125 PSIG
- 3 available outlet/gauge ports (one in front, one in back, and one in the bottom)
- Integral mounting holes allow for easy panel mounting
- Connects easily without adapters or independent manifold system
- Standard 5 mm tamper resistant adjustment
- High flow capability in relation to compact size (2.7" height x 1" square)
- Relieving or non-relieving models

#### Specifications

P1 Ports: 1/8 NPTF

Outlet/Gauge Ports: 10-32 UNF

Temperature Range: 40 -120 F (4-50 C)

Max Inlet Pressure: 200 PSIG (14 Bar)

Weight: .15 lbs (68 grams)

\*\*SCFM w/100 PSI inlet set @ 75: 5 scfm

\*\*SCFM w/100 PSI inlet set @ 60: 4 scfm

\*\*SCFM w/100 PSI inlet set @ 40: 3 scfm

Body material: Aluminum

\*\* based on a 25% pressure drop from set

#### Optional Accessories

ITEM	PART NO.
23mm Gauge "G" Option	NG23-M
10-32 - 1/8 NPTF Adapter	134-034
10-32 - 1/8 O.D Barb Fitting	134-236
10-32 - 1/4 O.D Barb Fitting	134-234

Each Regulator includes an R02K assembly kit which includes (1) 10-32 pipe plug, (1) 1/8 pipe plug, (1) P1 port o-ring, (2) connector screws

### How to Order

**MR 02 R - 01 G**

**Model**  
MR = Manifold Regulator

**Series**  
02

**Style**  
R = Relieving  
N = Non-Relieving

**Options**  
G = Gauge  
I = 0-25 PSI  
L = 0-60 PSI

**Port Size**  
01 = 1/8  
P1 ports are 1/8,  
outlet/gauge ports are 10-32

**Threads**  
- = NPTF  
G = G Tap (BSPP)  
R = PT (BSPT)



Numatics FRL  
Accessories and Options



Miniature Manifold Regulator

MR02 Series

Product Cross Section

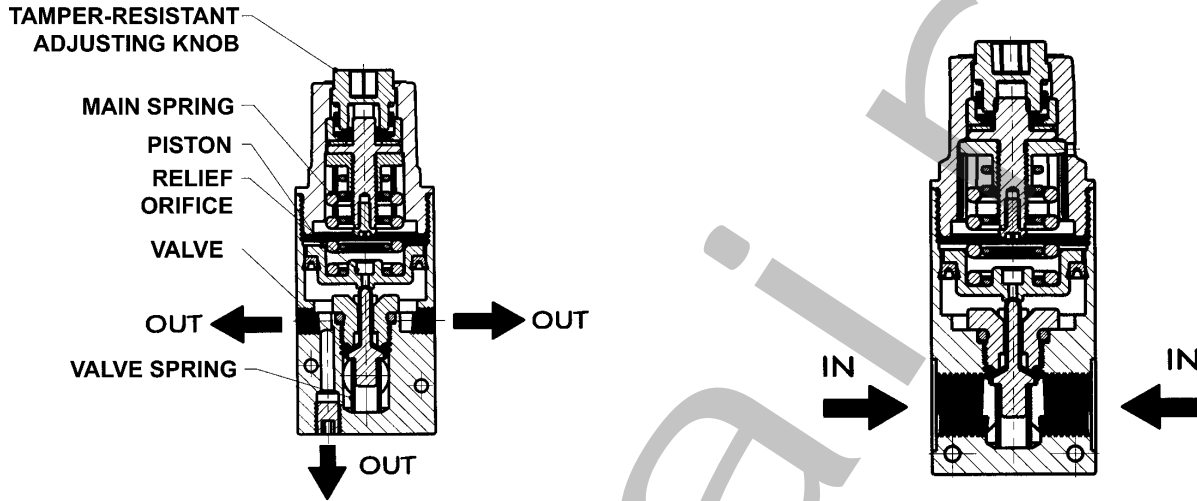

Dimensions

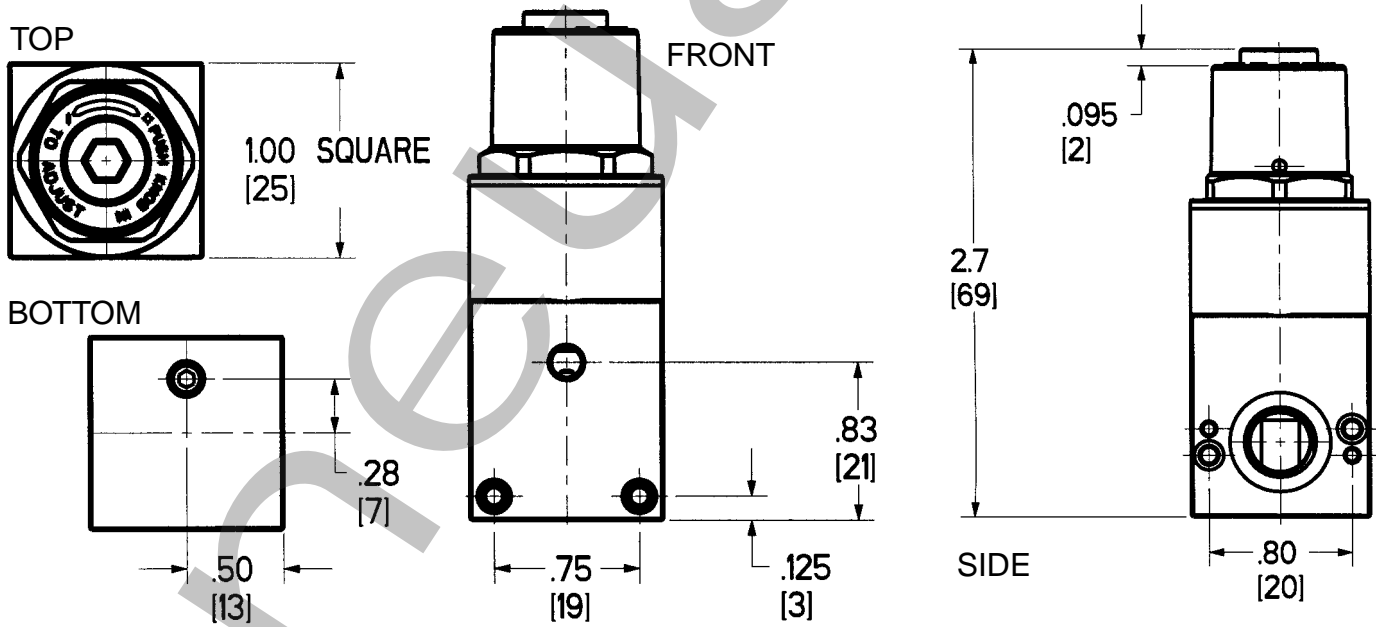

Flow Ratings

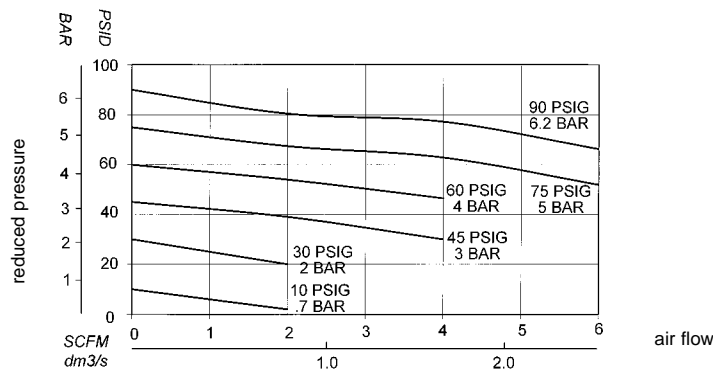



## Oxygen Concentrator Regulator

### Application

The 03 series specialty miniature regulator is designed for applications requiring precision control at a very low cost. Used primarily in OEM applications, the 03 series can be applied in applications using air, nitrogen, oxygen, water, and other inert gases/fluids. Its lightweight all plastic design allows use in many specialty environments. This regulator has been applied successfully in many different markets including:

- Oxygen: concentrators, analyzers, anesthesia
- Adhesive: Applicators, metering equipment
- Paint: spray systems, head control
- Water service: filtration, control, aeration
- Test equipment: leak test, air gauging, flow test

### Features

- Flows accurate to 0.1 psi in low flow applications
- Four spring ranges available as a standard. 0-15 psi, 0-30 psi, 0-60 psi, 0-100psi.
- Relieving or non relieving models.
- Tamper-resistant or adjustable designs available.
- Body Design Features
  - 101 /102 series*
    - Barb fitting outlet designed for use with 1/4 inch id tubing allows fast assembly.
    - Threaded 1/8 supply is male eliminates extra fitting.
    - Tamperproof or preset knob.
  - 201 / 202 series*
    - Barb fitting outlet designed for use with 1/8 inch id tubing allows fast assembly.
    - Manifold inlet and outlet ports.
    - Quick assembly with fixed height dimension.
    - Tamperproof or preset knob.

### Specifications

Temperature Range: 40-120F (4-50C)  
 Max inlet Pressure: 150 PSIG (10bar)  
 Weight:  
 SCFM with 100psi inlet set at 75 psi: 70 lpm  
 SCFM with 100psi inlet set at 60 psi: 50 lpm  
 SCFM with 100psi inlet set at 40 psi: 30 lpm  
 SCFM with 100psi inlet set at 10 psi: 10 lpm  
 Body Material: Delrin

Dimensions in inches (millimeters in parenthesis)

R03N-101

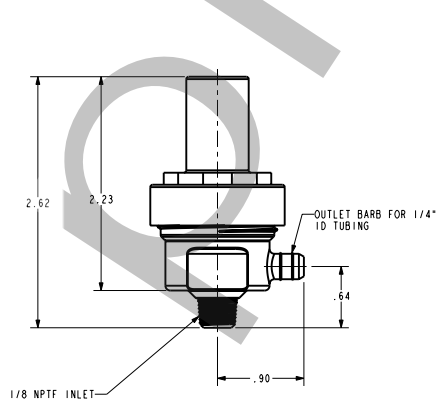

R03N-102

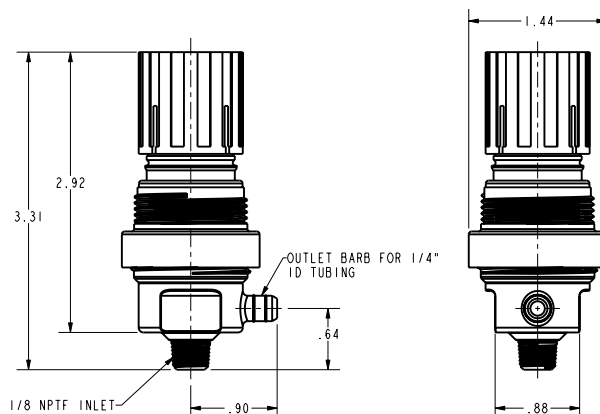





## Oxygen Concentrator Regulator

Dimensions in inches (millimeters in parenthesis)

R03N-201

R03N-202

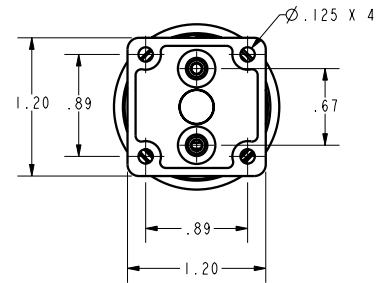
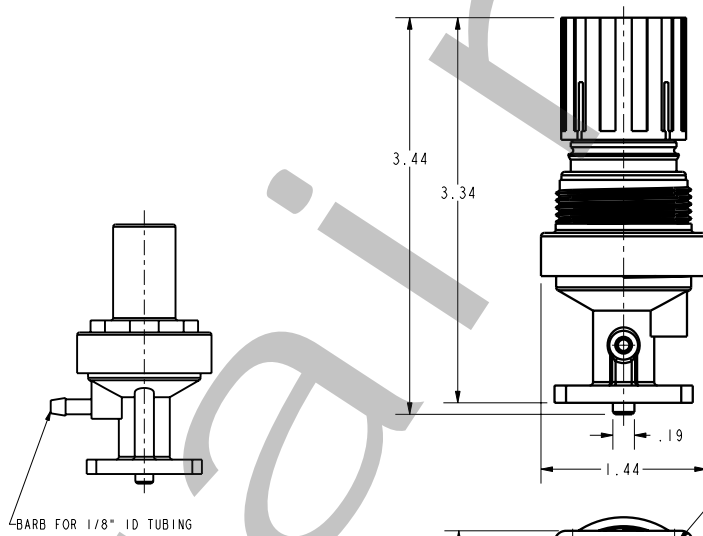
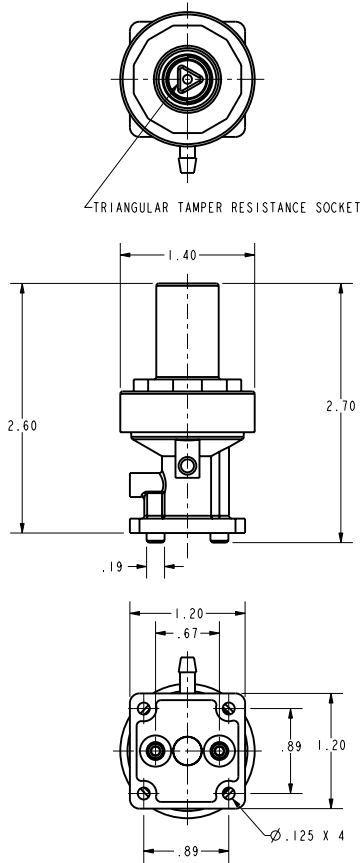

### How to Order

**R03 N - 101**

Series — Oxygen Concentrator Regulator

Style  
N = Relieving  
R = Non-Relieving

Model  
101/102 = 1/8 NPT Bottom Connection (barb outlet, see drawings)  
201/202 = Manifold Inlet/Outlet (see drawings)



## Numatics FRL Accessories and Options

### Gauges



GA300 pictured



214-194 pictured

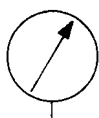

ANSI SYMBOL

### Application

Numatics gauges are widely used on compressors, filter/regulators ('piggybacks'), water pumps, paint sprayers, and a variety of other applications for measuring the pressure of the air passing through the component.

Numatics Liquid Filled pressure gauges provide maximum service life for your pneumatic gauge applications. Each glycerine filled model is designed to prevent harmful environments or severe vibration from causing premature gauge failure.

### Features

- Utilizes a Power Flex movement with polyester segment, contributing to longer gauge life.
- ABS (Acrylonitrile, Butadiene, Styrene) casing is ideal for rugged applications and harsh environmental conditions
- Full view polycarbonate window for better dial visibility.

### Specifications

All Numatics Gauges  
 Sizes: 1.5", 2"  
 Case: Black ABS Composite  
 Ring: None  
 Window: Polycarbonate  
 Dial: Green, Red, and Black on White Background  
 Pointer: Black Aluminum  
 Socket: Brass  
 Liquid Filled Gauges  
 Liquid Used: Glycerine  
 Connection: Center Back Mount

### Available Models

#### Numatics Gauges

MODEL	FACE DIAMETER	THREAD SIZE	PRESSURE RANGE (PSIG)	PRESSURE RANGE (BAR)
GB005	2.0"	1/4 NPT	0-5	0-0.5
RB005	2.0"	1/4 BSPT	0-5	0-0.5
GB015	2.0"	1/4 NPT	0-15	0-1.0
RB015	2.0"	1/4 BSPT	0-15	0-1.0
GA030	1.5"	1/8 NPT	0-30	0-2.0
RA030	1.5"	1/8 BSPT	0-30	0-2.0
GA060	1.5"	1/8 NPT	0-60	0-4.0
RA060	1.5"	1/8 BSPT	0-60	0-4.0
GA100	1.5"	1/8 NPT	0-100	0-7.0
RA100	1.5"	1/8 BSPT	0-100	0-7.0
GA160	1.5"	1/8 NPT	0-160	0-11.0
RA160	1.5"	1/8 BSPT	0-160	0-11.0
GA300	1.5"	1/8 NPT	0-300	0-20.0
RA300	1.5"	1/8 BSPT	0-300	0-20.0
GB030	2.0"	1/4 NPT	0-30	0-2.0
RB030	2.0"	1/4 BSPT	0-30	0-2.0
GB060	2.0"	1/4 NPT	0-60	0-4.0
RB060	2.0"	1/4 BSPT	0-60	0-4.0
GB100	2.0"	1/4 NPT	0-100	0-7.0
RB100	2.0"	1/4 BSPT	0-100	0-7.0
GB160	2.0"	1/4 NPT	0-160	0-11.0
RB160	2.0"	1/4 BSPT	0-160	0-11.0
GB300	2.0"	1/4 NPT	0-300	0-20.0
RB300	2.0"	1/4 BSPT	0-300	0-20.0

#### Numatics 14 Series Manifold Regulator Gauges

MODEL	FACE DIAMETER	THREAD SIZE	PRESSURE RANGE (PSIG)	PRESSURE RANGE (BAR)
GB060A	1.5"	1/4 NPT	0-60	0-4.0
RB060A	1.5"	1/4 BSPT	0-60	0-4.0
GB160A	1.5"	1/4 NPT	0-160	0-11.0
RB160A	1.5"	1/4 BSPT	0-160	0-11.0

#### Numatics Liquid-Filled Gauges

MODEL	FACE DIAMETER	THREAD SIZE	PRESSURE RANGE (PSIG)	PRESSURE RANGE (BAR)
214-194	1.5"	1/8	0-160	0-11
214-195	2.0"	1/4	0-160	0-11