

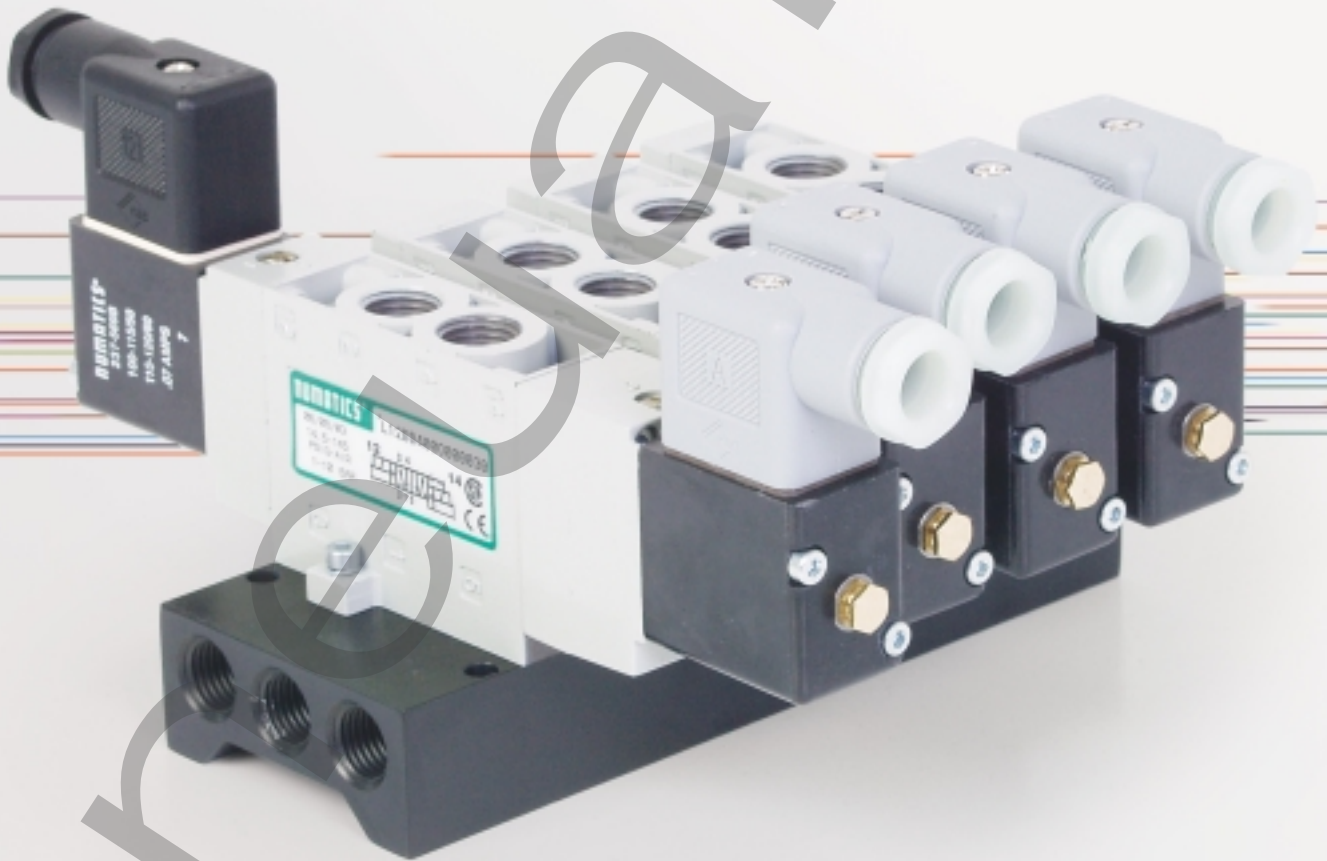

Valves



L1 Series

Solenoid Pilot or Air Pilot Actuated Valves

We're everywhere you need us to be!



L1 Series

Technical and Operating Data	3-11
How to Order	3-4
Valve Dimensions	5
Manifold Assembly	6-7
Internal/External Pilot Selection	8
Blank Station Plate Kit	9
Adaptor Kit	9
Blocking Plug Kit	9
Solenoid Assemblies	9
Valve Service Kits and Parts	10-11



L1 Series

single solenoid pilot
2 position 4-way

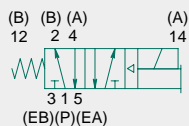

double solenoid pilot
2 position 4-way

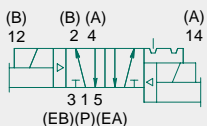

double solenoid pilot
3 position 4-way
open center

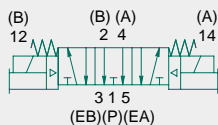

double solenoid pilot
3 position 4-way
closed center

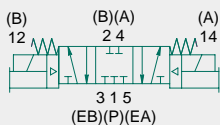

single air pilot
2 position 4-way

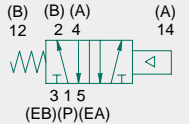

double air pilot
2 position 4-way

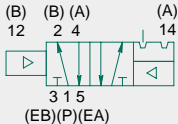

double air pilot
3 position 4-way
open center

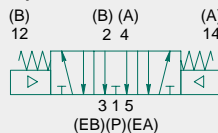

double air pilot
3-position 4-way
closed center

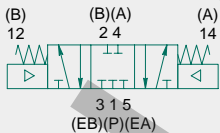

double air pilot
2 position 4-way
spring offset

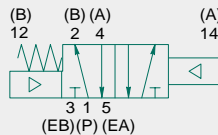

5 Ported, 2 and 3 position, 4-way, Spool & Sleeve
Cv: 1.0

- Solenoid pilot or air pilot actuated
- DIN plug-in solenoid and plug connector with indicator light
- Unlubricated or lubricated service
- In-line or manifold mounted



Technical Data

VALVE DATA	ENGLISH		METRIC	
Cv	1/8 = 1.0	1/4 = 1.0	1/8 = 1.0	1/4 = 1.0
Flow capacity	46 SCFM upstream pressure to atmosphere @ 80 PSIG		985 NI/m @ 6 bar upstream/5 bar downstream	
Main Valve Operating Pressure Range	28" HG. Vacuum to 150 PSIG		Vacuum to 10 bar	
Pilot Pressure Range: Internal and External	14.5 to 150 PSIG		1 to 10 bar	
Temperature range: Solenoid Pilot (ambient)	-10°F to +115°F		-23°C to +46°C	
Temperature Range: Air Pilot (ambient)	-10°F to +150°F		-23°C to +66°C	



L1 Series

Operating Data

ALL SOLENOIDS ARE CONTINUOUS DUTY RATED		12 VDC	24 VDC	24 V AC 50 Hz.	24 VAC 60 Hz.	115 VAC 50 Hz.	120 VAC 60 Hz.	230 VAC 50 Hz.	240 VAC 60 Hz.
*Power (Watts)		3.5	3.5	4.8	3.3	4.8	4.0	5.0	3.5
Holding Current (Amps.)		0.30	0.15	0.380	0.280	0.064	0.054	0.030	0.023
Inrush Current (Amps.)		N/A	N/A	0.500	0.420	0.087	0.082	0.042	0.036
Energize in seconds	2-Position, Single, Spring Return	0.010	0.010	0.007	0.007	0.007	0.007	0.007	0.007
	2-Position, Double, Detented	0.010	0.010	0.007	0.007	0.007	0.007	0.007	0.007
	3-Position, Spring Centered	0.010	0.010	0.007	0.007	0.007	0.007	0.007	0.007
De-energize in seconds	2-Position, Single, Spring Return	0.035	0.035	0.035	0.035	0.035	0.035	0.035	0.035
	2-Position, Double, Detented	N/A	N/A	N/A	N/A	N/A	N/A	N/A	N/A
	3-Position, Spring Centered	0.030	0.035	0.035	0.035	0.035	0.035	0.035	0.035

*A 1.4 Watt DC solenoid is available. Add "17G" to the model number. **EXAMPLE:** L12BA400B017G61.
Maximum pilot pressure is reduced to 116 PSIG (8 bar).

L1 Series

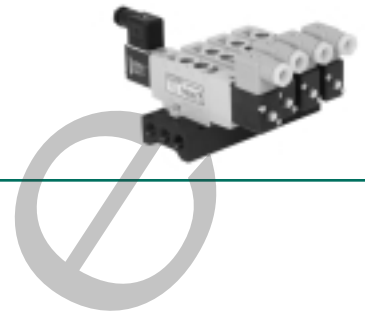

How to Order

Valves

L12 PA 4 52 O 0 000 00

Valve Series & Port Size

- L11 = 1/8
- L12 = 1/4

Valve Type

- BA = Single Solenoid Pilot, Spring Return W/Flush Locking Override
- BB = Double Solenoid Pilot W/Flush Locking Override
- PA = Single Air Pilot w/Spring Return
- PP = Double Air Pilot
- PM = Double Air Pilot w/Spring Offset

Function

- 4 = 2 Position, 4-Way
- 5 = 3 Position, 4-Way Open Center
- 6 = 3 Position, 4-Way Closed Center

Mounting

- 00 = Valve Unit w/Manifold Mounting Tabs
- 52 = Line Mounted (Manifold Mount with Adapter)

Voltage

- 20 = 24/50-60 VAC
- 30 = 110-120/50-60 VAC
- 40 = 220-240/50-60 VAC
- 60 = 12 VDC
- 61 = 24 VDC
- 00 = N/A (Used with Air Pilot)

Options

- 14A = External Pilot Supply
- 17G = Low Watt Solenoid 1.42 Watt
- 17P = Flush Non-locking Override
- 18D = Side Ports (see p. 6)

Port Type

- 0 = NPTF
- G = G tap

Wiring Option

- B = DIN Plug-In DC Solenoid
- O = DIN Plug-In AC Solenoid or Air Pilot

NOTE: Plug connector is NOT included with DIN solenoid. Order plug-in connector assembly separately (see ordering information below)

Plug Connector Assemblies

Per DIN Spec. NO 43650. Accepts cable diameter 0.240 to 0.310 11mm Industry Standard DIN Form B

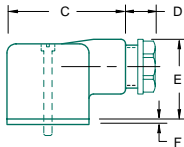
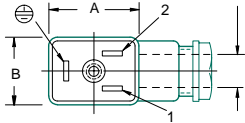

Normal Polarity
 1 = (+) Positive, High
 2 = (-) Negative, Neutral
 ⊕ = Chassis Ground

PLUG CONNECTOR DESCRIPTION	PART NO.
Grey (14 end solenoid) Plug Assembly	230-363
Black (12 end solenoid) Plug Assembly	230-364
Plug Assembly with 24 V Light	230-365
Plug Assembly with 110 V Light	230-366
Plug Assembly with 220 V Light	230-367

Dimensions

top dimensions = inches and bottom dimensions (in parenthesis) = millimeters

A	B	C	D	E	F
1.12 (28.5)	0.83 (21.1)	1.57 (39.9)	0.40 (10.2)	1.10 (27.9)	0.06 (1.5)

Manifold Assembly

AK 0 2 C 0000 2 N STD

Electrical/Electronics Type & Location

- 0 = Standard

Valve Line

- 2 = L1 Series

Number of Valve Stations

- A = 1 E = 5 I = 9
- B = 2 F = 6 J = 10
- C = 3 G = 7 K = 11
- D = 4 H = 8 L = 12

Options

- A21 = Used with Valve Units with Manifold Mounting Tabs (valve mounting = 00)
- STD = Used with Line Mounted Valves, Includes Adaptor Kits (valve mounting = 52)

Port Type

- N = NPTF
- G = G tap

End Plate Port Size

- 2 = 1/4

Example order:

- Assembly Kit: AK02D00002NA21
- Station 1: L12BB500O000030
- Station 2: L12BA400O000030
- Station 3: L12PP400O000000
- Station 4: L12PA400O000000
- ASSEMBLED



L1 Series

Solenoid-Pilot Valve

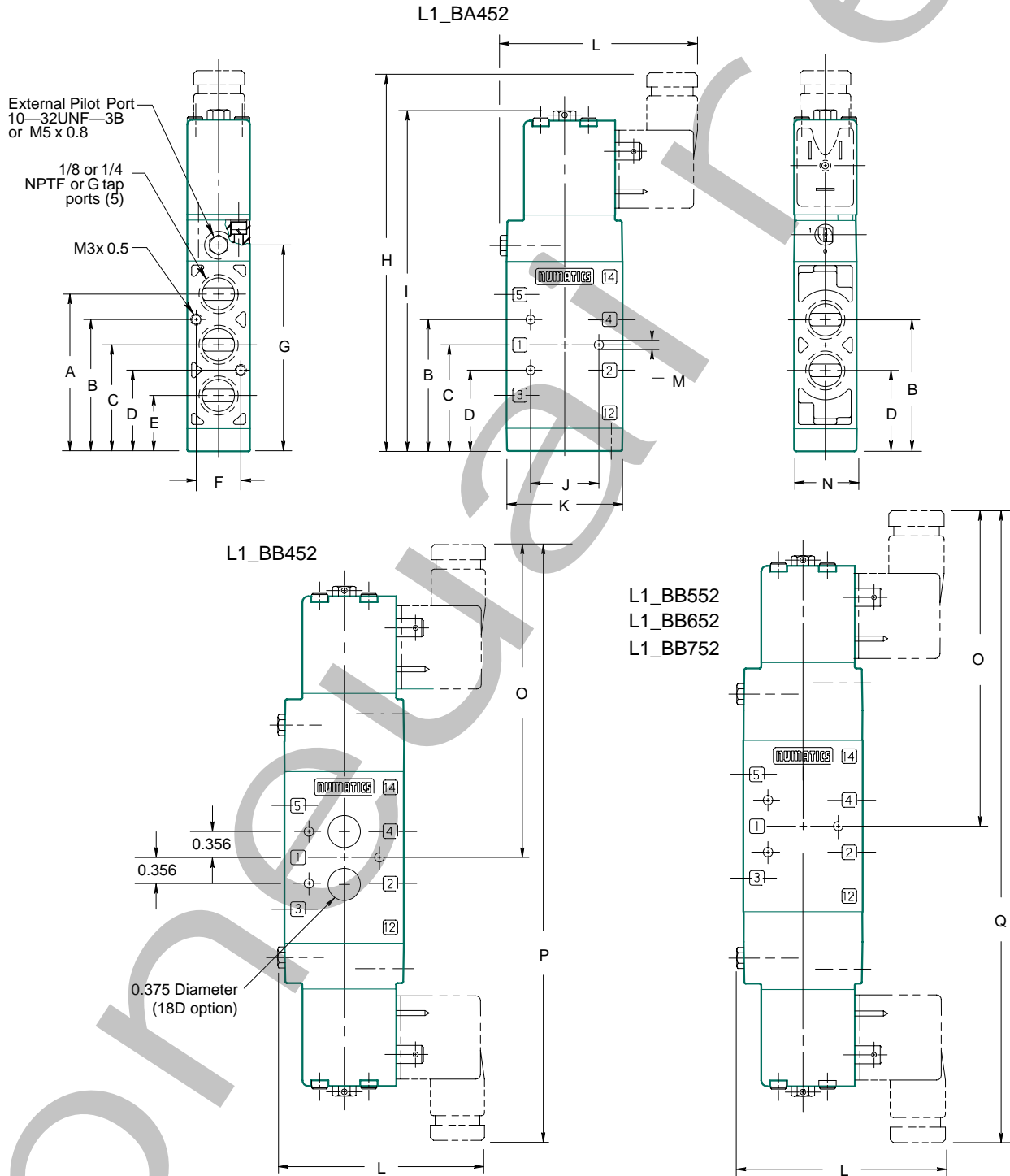

Dimensions

top dimensions = inches and bottom dimensions (in parenthesis) = millimeters

A	B	C	D	E	F	G	H	I	J	K	L	M	N	O	P	Q
2.21 (56.1)	1.85 (47.0)	1.50 (38.1)	1.14 (29.0)	0.78 (19.8)	0.62 (15.7)	2.90 (73.6)	5.41 (137.4)	4.85 (123.2)	0.96 (24.4)	1.62 (41.1)	2.77 (70.4)	0.13 (3.3)	0.88 (22.4)	4.32 (109.7)	8.23 (209.0)	8.64 (219.5)



L1 Series

Air-Pilot Valve L1_PA452

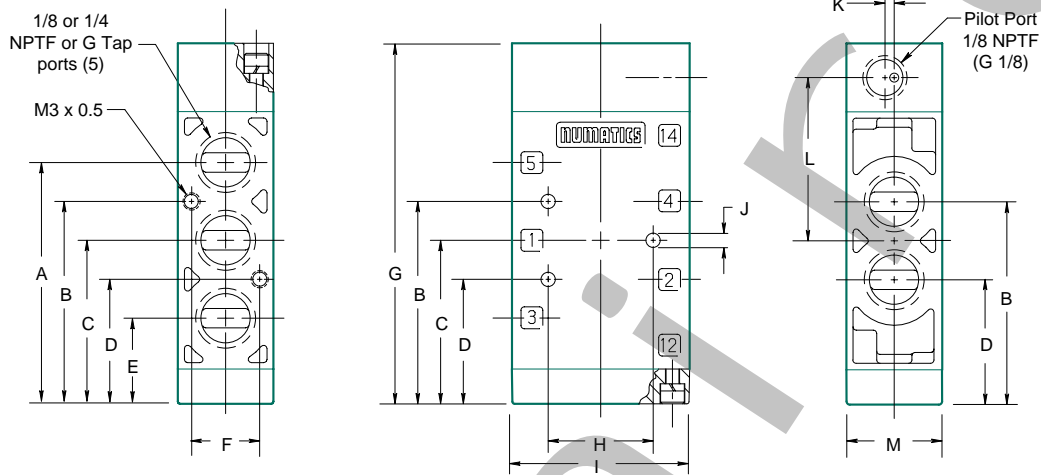

Dimensions

top dimensions = inches and bottom dimensions (in parenthesis) = millimeters

A	B	C	D	E	F	G	H	I	J	K	L	M
2.21	1.85	1.50	1.14	0.78	0.62	3.30	0.96	1.62	0.13	0.09	1.49	0.88
(56.1)	(47.0)	(38.1)	(29.0)	(19.8)	(15.7)	(83.8)	(24.4)	(41.1)	(3.3)	(2.2)	(37.9)	(22.4)

Air-Pilot Valve L1_PP452, L1_PP552, L1_PP652, L1_PP752, L1_PM452

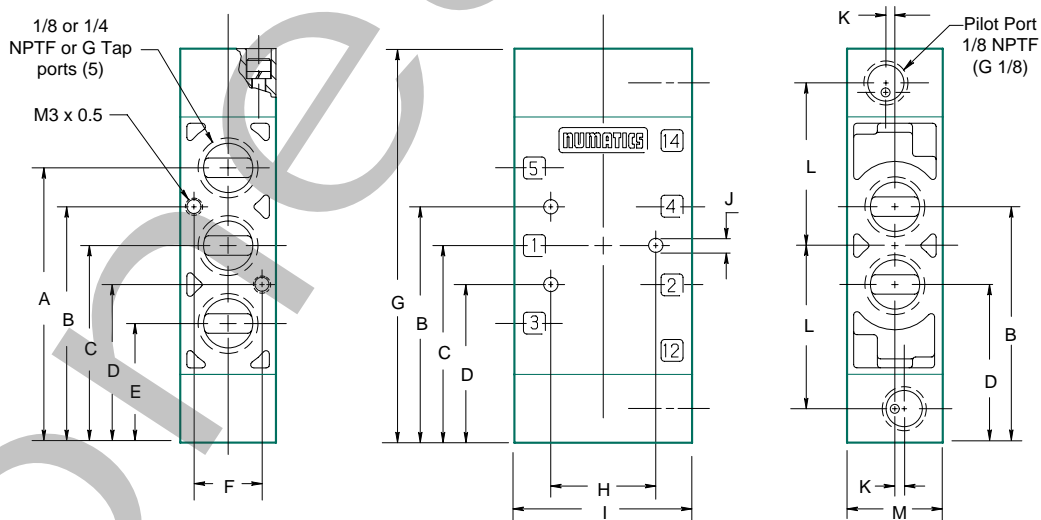

Dimensions

top dimensions = inches and bottom dimensions (in parenthesis) = millimeters

A	B	C	D	E	F	G	H	I	J	K	L	M
2.52	2.16	1.80	1.45	1.09	0.62	3.61	0.96	1.62	0.13	0.09	1.49	0.88
(64.0)	(54.9)	(45.7)	(36.8)	(27.7)	(15.7)	(91.6)	(24.4)	(41.1)	(3.3)	(2.2)	(37.9)	(22.4)



L1 Series

Manifold Assembly

Valve with Mounting Tabs

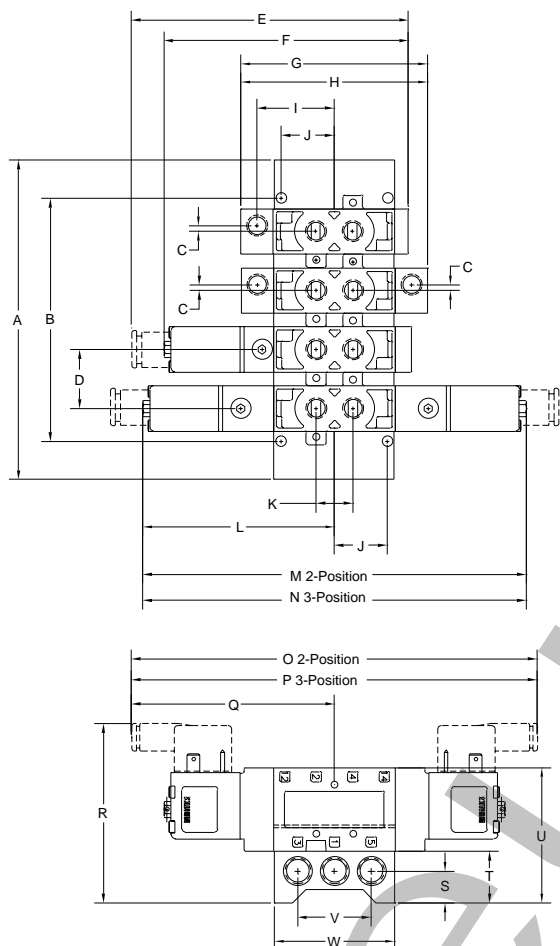

Valve with Adaptor Plate

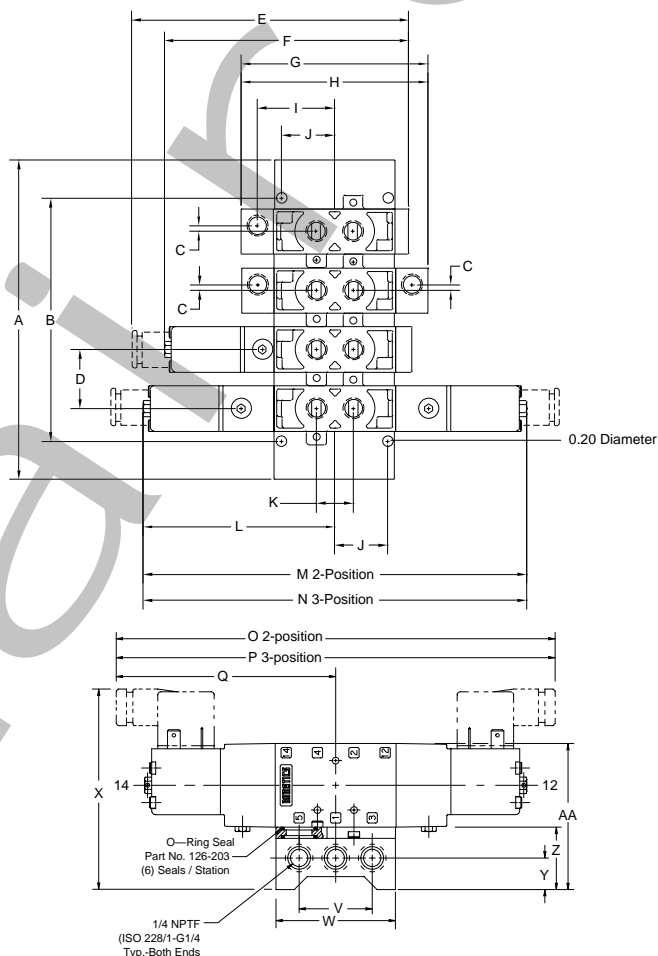

Dimensions

top dimensions = inches and bottom dimensions (in parenthesis) = millimeters

A	B	C	D	E	F	G	H	I	J	K	L	M	N	O	P
See Below	See Below	0.09 (2.3)	1.14 (29.0)	5.36 (136.1)	4.81 (122.2)	3.61 (91.7)	1.80 (45.7)	1.49 (37.8)	1.031 (26.2)	0.71 (18.0)	3.71 (94.2)	7.03 (178.6)	7.45 (189.2)	8.14 (206.8)	8.55 (217.2)
Q	R	S	T	U	V	W	X	Y	Z	AA					
4.27 (108.5)	3.47 (88.1)	0.61 (15.5)	0.99 (25.1)	2.62 (66.5)	1.42 (36.1)	2.33 (59.2)	3.89 (98.8)	0.61 (15.5)	1.21 (30.7)	2.84 (72.1)					

# OF STATIONS	MANIFOLD KIT NO.		DIMENSIONS		# OF STATIONS	MANIFOLD KIT NO.		DIMENSIONS	
	1/4 NPTF	G 1/4	A	B		1/4 NPTF	G 1/4	A	B
2 Stations	106-1063	106-1096	3.90 (99.1)	2.43 (61.7)	8 Stations	106-1069	106-1102	10.72 (272.3)	9.25 (234.9)
3 Stations	106-1064	106-1097	5.03 (127.8)	3.56 (90.4)	9 Stations	106-1070	106-1103	11.86 (301.2)	10.38 (263.7)
4 Stations	106-1065	106-1098	6.17 (156.7)	4.70 (119.4)	10 Stations	106-1071	106-1104	12.99 (329.9)	11.52 (292.6)
5 Stations	106-1066	106-1099	7.31 (185.7)	5.84 (148.3)	11 Stations	106-1072	106-1105	14.13 (358.9)	12.66 (321.6)
6 Stations	106-1067	106-1100	8.45 (214.6)	6.97 (177.0)	12 Stations	106-1073	106-1106	15.27 (387.9)	13.80 (350.5)
7 Stations	106-1068	106-1101	9.58 (243.3)	8.11 (206.0)	Adaptor Kit	239-311	Order (1) adaptor kit for each station on the manifold Includes all seals and screw		



Internal / External Pilot Supply

INTERNAL PILOT SUPPLY



PILOT SUPPLY HOLE MUST BE VISIBLE BOTH ENDS

EXTERNAL PILOT SUPPLY



ROTATE GASKET TO COVER PILOT SUPPLY HOLE. REMOVE PIPE PLUG (PART NO. 127-588)

Blank Station Plate Kit 239-288

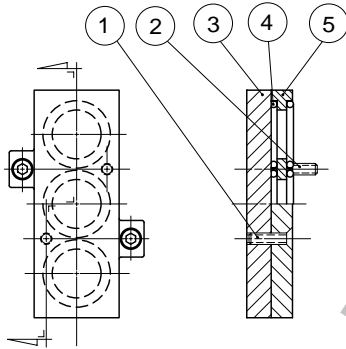

Parts List

DET. NO.	NO. REQ'D	PART NAME	PART NO.
1	2	Screw	127-622
2	2	Screw	127-570
3	1	Blank Station Plate	119-352
4	6	O-Ring	126-203
5	1	Adaptor	119-353

Adaptor Kit 239-311

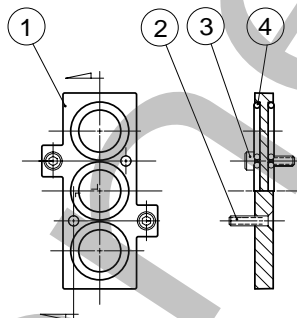

Parts List

DET. NO.	NO. REQ'D	PART NAME	PART NO.
1	1	Adaptor	119-353
2	2	Screw	127-622
3	2	Screw	127-570
4	6	O-Ring	126-203

Blocking Plug Kit 239-309

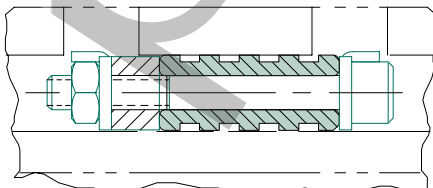

Solenoid Assemblies

STANDARD VOLTAGES	100-115/50 115-120/60 VAC	200-240/50 220-240/60 VAC	24/50-60 VAC	12 VDC	24 VDC
Part No.	237-569	237-570	237-568	226-737	226-749



L1 Series

Valve Service Kits and Parts – 2 Position

Solenoid-Pilot Actuated

Kit No. L1-K1 (For Models L11BA4, L12BA4)

Kit No. L1-K2 (For Models L11BB4, L12BB4)

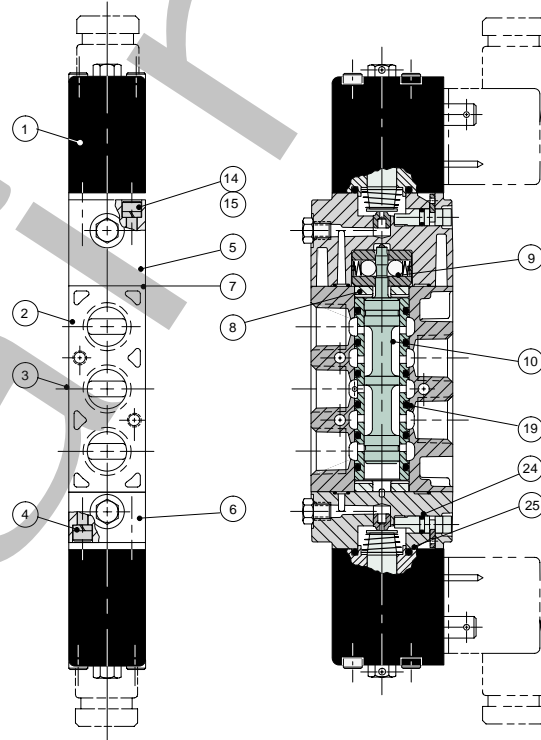
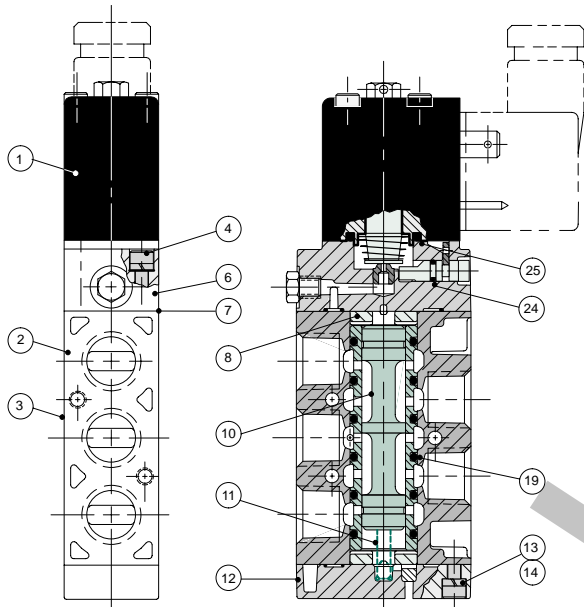

Air-Pilot Actuated

Kit No. L1-K1 (For Models L11PA4, L12PA4
L11PM4, L12PM4)

Kit No. L1-K2 (For Models L11PP4, L12PP4)

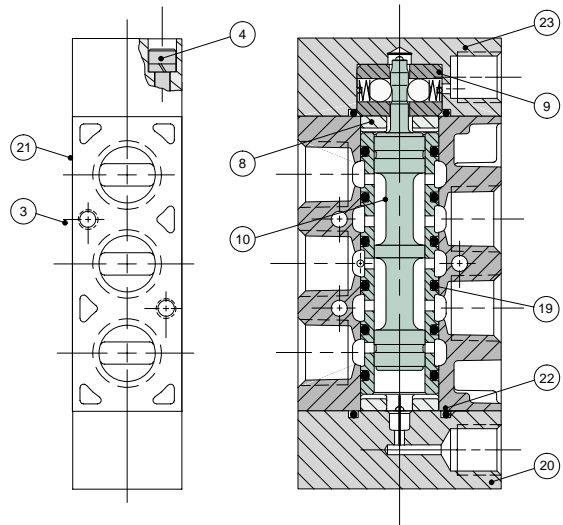
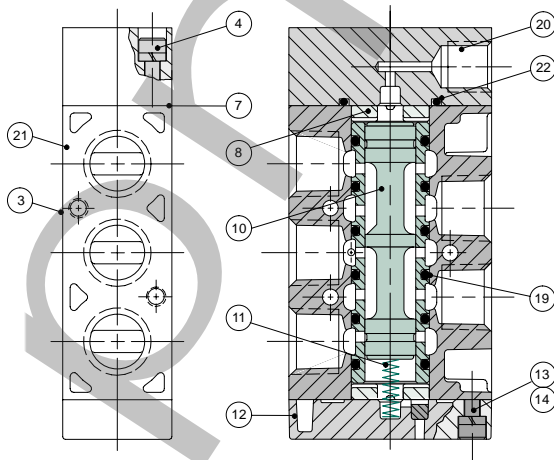



L1 Series

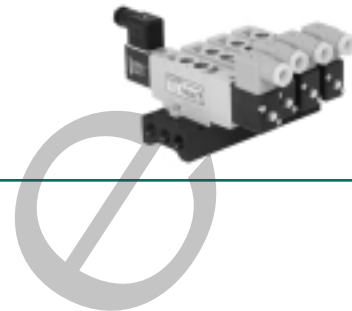

Valve Service Kits and Parts – 3 Position

Solenoid-Pilot Actuated

Kit No. L1-K3 (For Models L1-BB5, L1-BB6, L1-BB7)

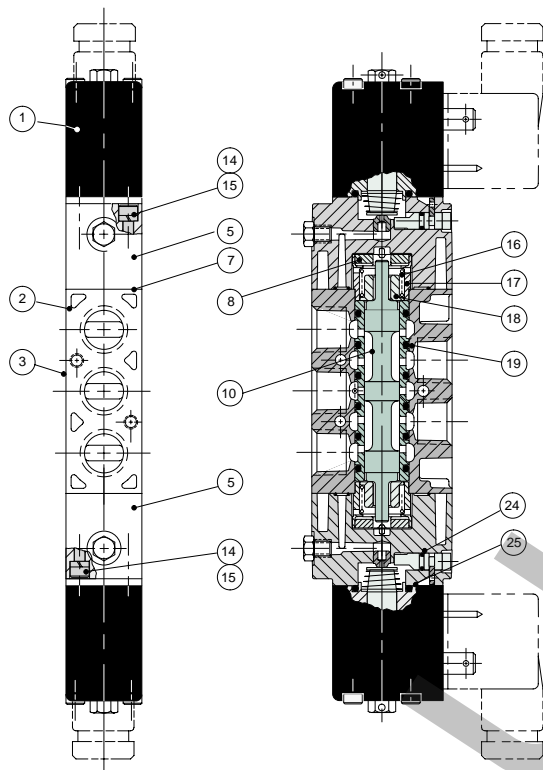

Parts List

DET. NO.	NO. REQ'D	PART NAME	PART NO.
1	1	Solenoid Capsule Assembly	See p. 9
2	1	Solenoid-Pilot Body (not sold separately)	
3	1	Nameplate	122-943
4	2	Screw Assembly	127-392
5		Adaptor Assembly	219-175
6	1	Adaptor Assembly	219-177
7 *	2	Gasket	113-401
8 *	2	Bumper	114-172
9 **	1	Detented Assembly	210-118
10	1	Sleeve Assembly w/Seals for models: L1-BA4, L1PA4 L1-BB4, L1PP4 L1-BB5, L1PP5 L1-BB6, L1PP6 L1-BB7, L1PP7	209-377 209-378 209-379 209-380 209-381
11	1	Spring	115-293
12	1	Spring Cover Assembly	204-469
13	2	Screw	127-564
14		Lockwasher	128-239
15	2	Screw	127-563
16 ***	2	Spring	115-225
17 ***	2	Spacer	116-398
18	2	Spring Retainer	116-399
19 *	6	O-Ring Seal	126-202
20	1	Pilot Cap	104-411
21	1	Air-Pilot Body (not sold separately)	
22 *		O-Ring Seal	126-205
23		Pilot Cap	104-413
24 *	2	Seal (override)	126-203
25 *	2	Seal (solenoid pilot)	126-163

Air-Pilot Actuated

Kit No. L1-K3 (For Models L1-PP5, L1-PP6, L1-PP7)

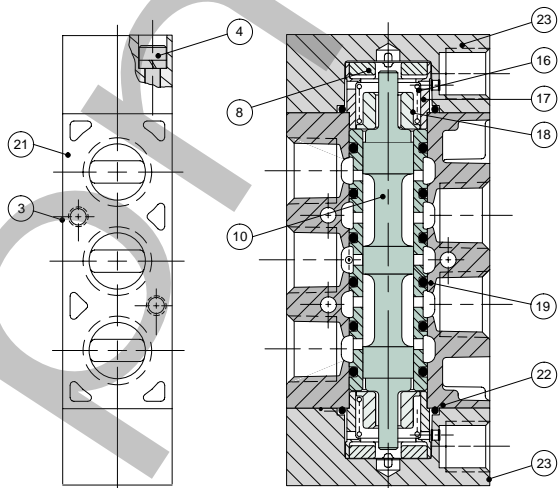

* indicates parts in L1-K1, L1-K2, and L1-K3
 ** indicates part in L1-K2 only
 *** indicates part in L1-K3 only