

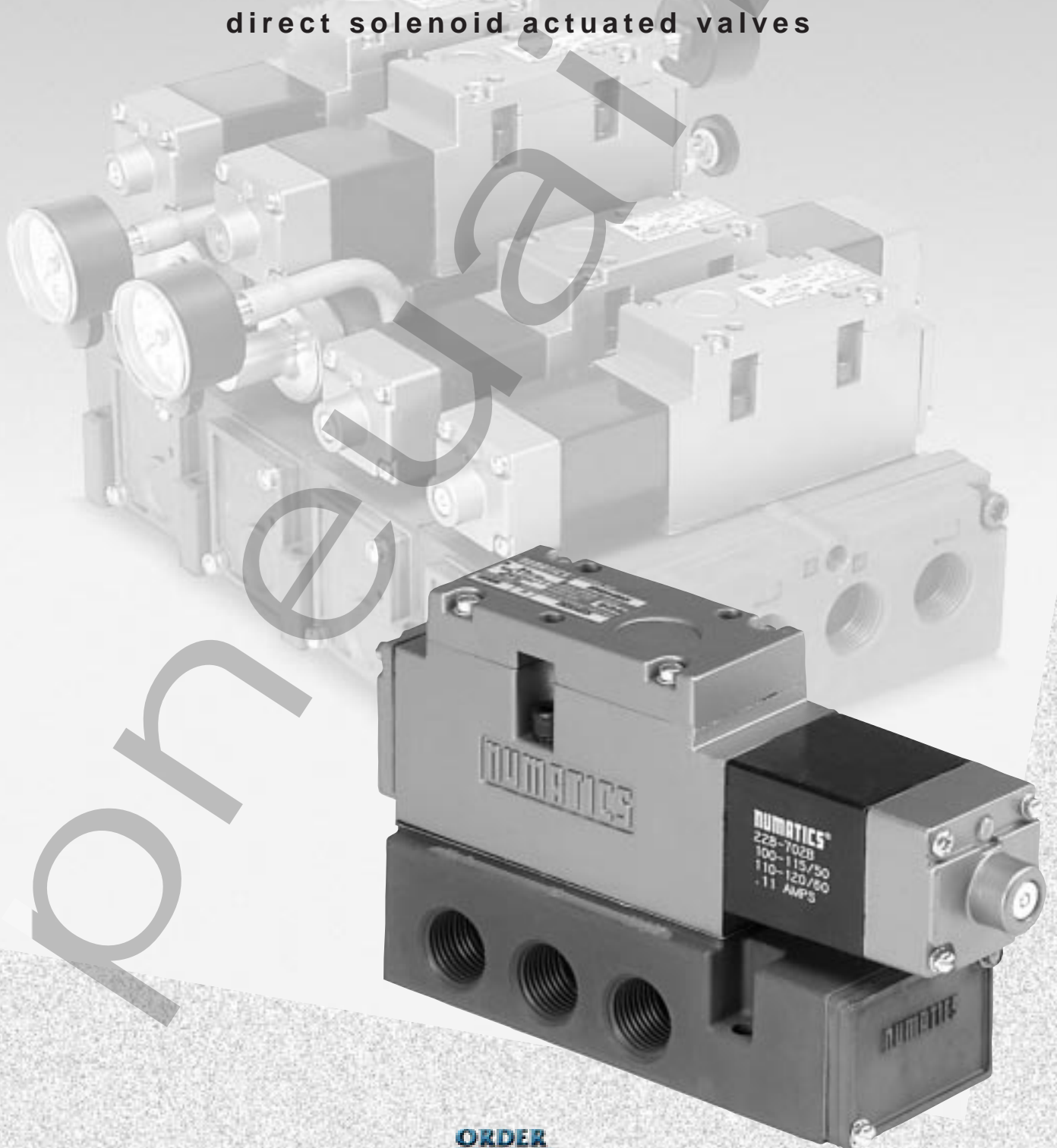

# MARK 25 SERIES

direct solenoid actuated valves



## Mark 25 direct solenoid actuated valves

TECHNICAL DATA .....	3
VALVE MODEL SELECTION .....	3
VALVE/BASE DIMENSIONS .....	4
FLEXIBLOK MANIFOLDS .....	5
SANDWICH PRESSURE REGULATORS .....	6-7
REGULATOR KITS .....	7
BASE ASSEMBLY KITS .....	8
FLEXIBLOK MANIFOLD KITS .....	8
MANIFOLD ACCESSORY KITS .....	8-9
SOLENOID ASSEMBLY KITS .....	9
VALVE SERVICE KITS .....	10-11

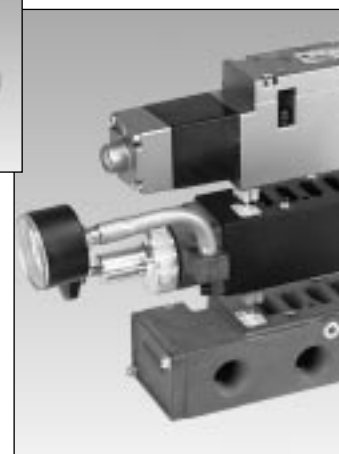
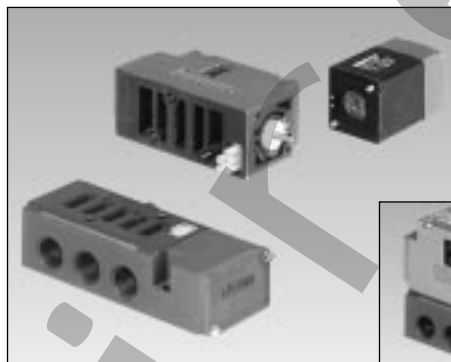

### MARK 25 PLUG-IN FEATURES:

Mark 25 valves have a plug-in base or manifold, a plug-in solenoid, and an optional plug-in sandwich pressure regulator. The unit to base electrical plug permits instant valve unit replacement without disconnecting piping or wiring.

MARK 25

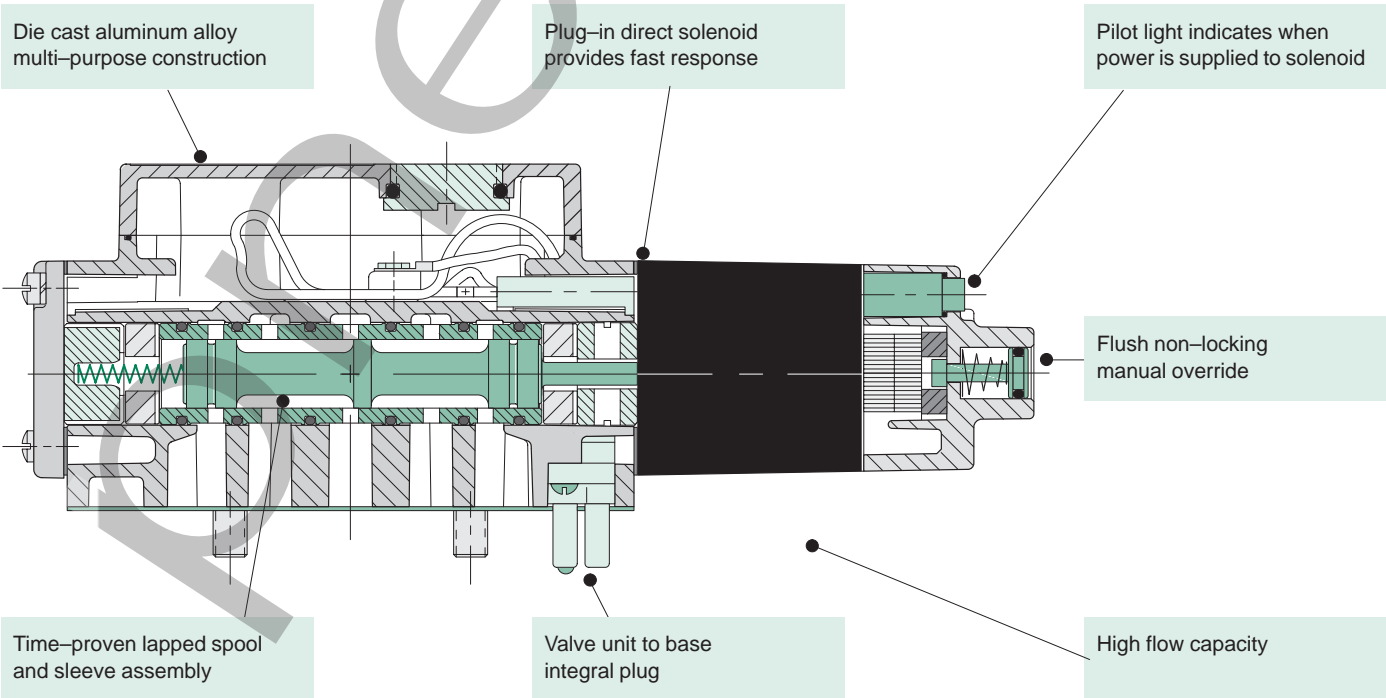

**Mark 25 valves**

- direct solenoid actuated
- plug-in solenoid with indicator light
- multi-purpose
- 5-ported, 4-way, 2 and 3 position
- lapped spool and sleeve assembly
- Cv to 2.3
- 1/4, 3/8, and 1/2 NPTF or G tap ports
- for unlubricated or lubricated service
- integral plug-in regulators available
- NEMA 4

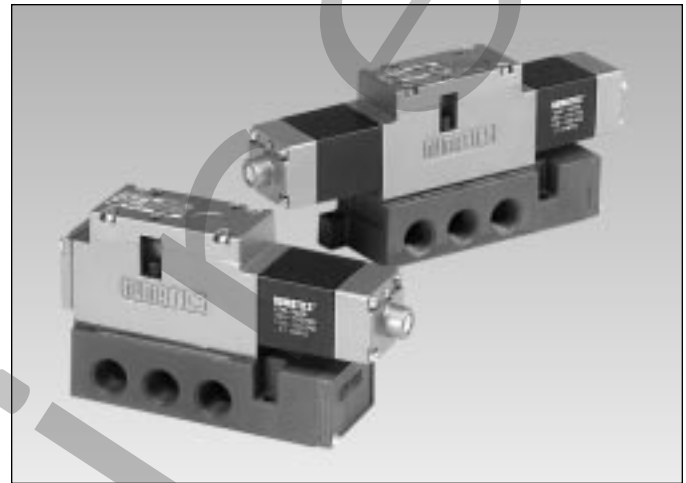

**Technical data**

Valve Data	NPTF			G tap		
Cv:	1/4 = 1.8	3/8 = 2.1	1/2 = 2.3	1/4 = 1.8	3/8 = 2.1	1/2 = 2.3
Flow Capacity: upstream pressure to atmosphere @ 80 PSIG	83 SCFM	97 SCFM	107 SCFM	1773 NI/m @ 6 Bar upstream/5 Bar downstream	2069 NI/m	2266 NI/m
Operating Pressure Range:	28" Hg. Vacuum to 150 PSIG			Vacuum to 10 Bar		
Temperature Range:	-10°F to +115°F ambient			-23°C to +46°C ambient		

**Operating data**

All solenoids are continuous duty rated.		12 VDC	24 VDC	24V AC 50 Hz	24V AC 60 Hz	115V AC 50 Hz	120V AC 60 Hz	230V AC 50 Hz	240V AC 60 Hz
Power (Watts)		6.0	6.0	—	—	—	—	—	—
Holding Current (Amps.)		0.50	0.25	0.59	0.42	0.11	0.09	0.07	0.05
Inrush Current (Amps.)		N/A	N/A	2.85	2.53	0.63	0.63	0.31	0.29
Time to energize in seconds	2-Position, Single, Spring Return:	0.038	0.034	0.010	0.010	0.010	0.010	0.010	0.010
	2-Position, Double, Detented:	0.035	0.035	0.010	0.010	0.010	0.010	0.010	0.010
	3-Position, Spring Centered:	0.040	0.040	0.010	0.010	0.010	0.010	0.010	0.010
Time to De-energize in seconds	2-Position, Single, Spring Return:	0.016	0.011	0.015	0.015	0.015	0.015	0.015	0.015
	2-Position, Double, Detented:	N/A	N/A	N/A	N/A	N/A	N/A	N/A	N/A
	3-Position, Spring Centered:	0.010	0.010	0.012	0.012	0.012	0.012	0.012	0.012

**Mark 25 model selection table** (standard valve/mounting combinations)

Valve Function	Ports NPTF	Individual base : side ports & individual exhaust		FlexiBlok manifold: side & bottom cylinder ports	
		AC*	DC*	AC*	DC*
 UNIT ONLY: 252SA400K (AC) / 252SA400M (DC)	1/4	252SA43AK	252SA43AM	252SA415K	252SA415M
	3/8	253SA43AK	253SA43AM	253SA415K	253SA415M
	1/2	254SA43AK	254SA43AM	254SA415K	254SA415M
 UNIT ONLY: 252SS400K (AC) / 252SS400M (DC)	1/4	252SS43AK	252SS43AM	252SS415K	252SS415M
	3/8	253SS43AK	253SS43AM	253SS415K	253SS415M
	1/2	254SS43AK	254SS43AM	254SS415K	254SS415M
 UNIT ONLY: 252SS500K (AC) / 252SS500M (DC)	1/4	252SS53AK	252SS53AM	252SS515K	252SS515M
	3/8	253SS53AK	253SS53AM	253SS515K	253SS515M
	1/2	254SS53AK	254SS53AM	254SS515K	254SS515M
 UNIT ONLY: 252SS600K (AC) / 252SS600M (DC)	1/4	252SS63AK	252SS63AM	252SS615K	252SS615M
	3/8	253SS63AK	253SS63AM	253SS615K	253SS615M
	1/2	254SS63AK	254SS63AM	254SS615K	254SS615M

\*Specify volts and Hz. after the model number.

DIN solenoid options: Replace the "K" with "6" for DIN AC plug-in with light. Replace "M" with "4" for DIN DC plug-in.

DIN AC EXAMPLE: 252SS43A6

G tap options: For G tap ports, add a "G" to the model number. EXAMPLE: 252SA43AMG

DIN DC EXAMPLE: 253SS5154

MARK 25



## Mark 25 valve & base dimensions

252SS4 single direct solenoid actuated valve

252SS4, 5, 6 double direct solenoid actuated valve (shown in phantom)

Base 1/4, 3/8, or 1/2 NPTF or G tap side ports

1/2 NPTF conduit port connection

### Dimensions

A	2.47 (62.7)
B	0.59 (15)
C	0.69 (17.5)
D	0.59 (15)
E	0.15 (3.8)
F	4.67 (119)
G	(2.33 (59.2))
H	0.82 (21)
I	2.58 (65.6)
J	0.28 (7.1)
K	7.58 (193)
K	8.31 (211)
L	10.00 (254)
L	11.46 (291)
M	0.82 (21)
N	4.12 (105)
O	2.50 (66)
P	1.59 (40.4)
Q	0.75 (19)
R	0.59 (15)
S	1.18 (30)
T	6.54 (166)
U	1.08 (27.4)
V	2.16 (54.9)

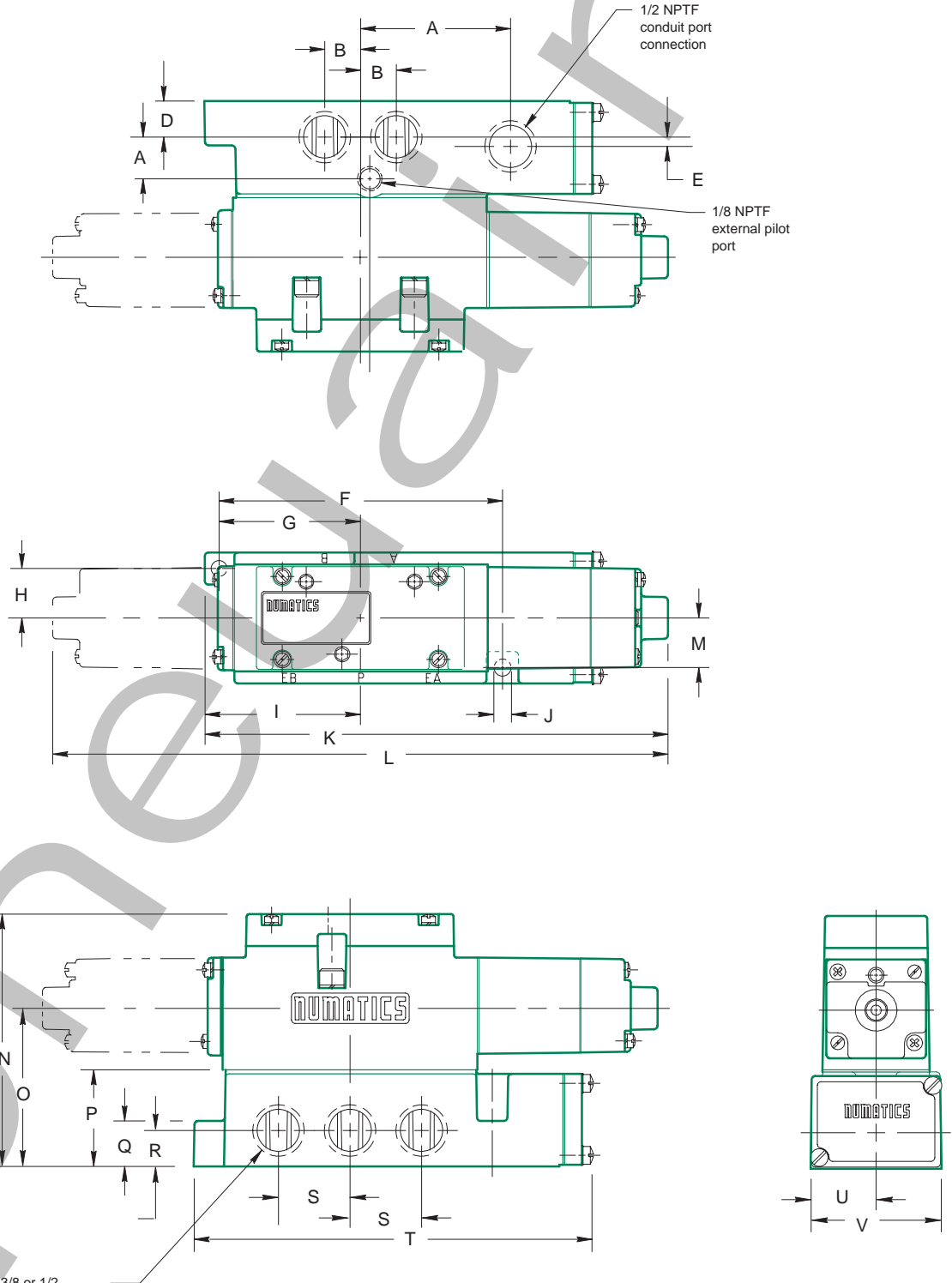

dimensions = inches  
(in parenthesis = mm)

1/4, 3/8 or 1/2  
NPTF or G Tap  
Side Ports (5)

MARK 25

## Mark 25 FlexiBlok manifolds

- stackable manifold mounting
- 1/4, 3/8, or 1/2 NPTF or G tap cylinder ports
- end plate tapped, both ends

### How to order

List in order, left to right, facing cylinder ports A and B: (example)

Assembly Kit:\* **AK25B-5**  
 Station 1: **254SA415K 120/60**  
 Station 2: **254SA415K 120/60**  
 Station 3: **254SA415K 120/60**  
 Station 4: **254SS415K 120/60**  
 Station 5: **254SS615K 120/60**  
**ASSEMBLED**

\*  
**AK25B-** + No. of Stations + Port Type  
 Blank = NPTF  
**G** = G Tap Galleries w/Metric Conduit  
**C** = G Tap Galleries w/NPTF Conduit

Kits include end plates, screws, assembly and testing for proper operation. Due to flow, wiring, and practical assembly limitations, a maximum of 12 stations per assembly is recommended.

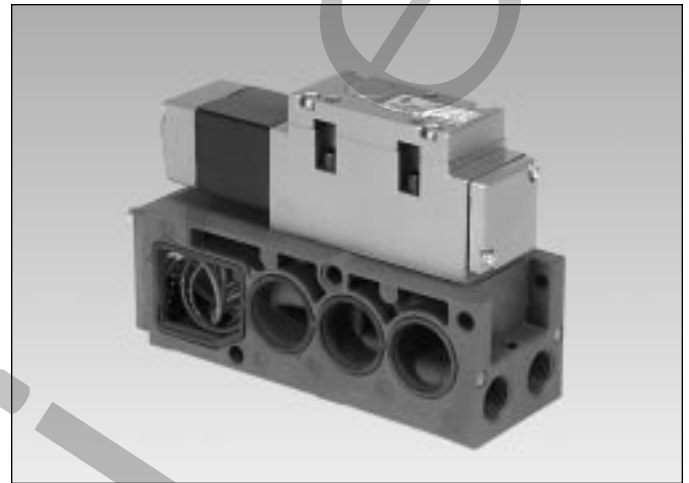

## Mark 25 FlexiBlok manifold dimensions

Dimensions	
A	11.53 (293)
AC	10.07 (256)
B	5.00 (127)
C	2.62 (66.5)
D	7.62 (194)
D	8.35 (212)
E	7.69 (195)
F	0.38 (9.7)
G	5.22 (133)
H	3.68 (93.5)
I	1.38 (35)
J	0.69 (17.5)
K	0.66 (17)
L	1.31 (33.3)
M	0.81 (20.6)
N	2.62 (66.5)
O	2.69 (68.3)
P	0.99 (25)
Q	1.19 (30.2)
R	1.50 (38)
S	3.38 (86)
T	7.13 (181)
U	2.38 (60.4)
V	0.47 (12)
W	1.06 (27)
X	0.69 (17.5)
Y	0.71 (18)
Z	0.45 (11.4)

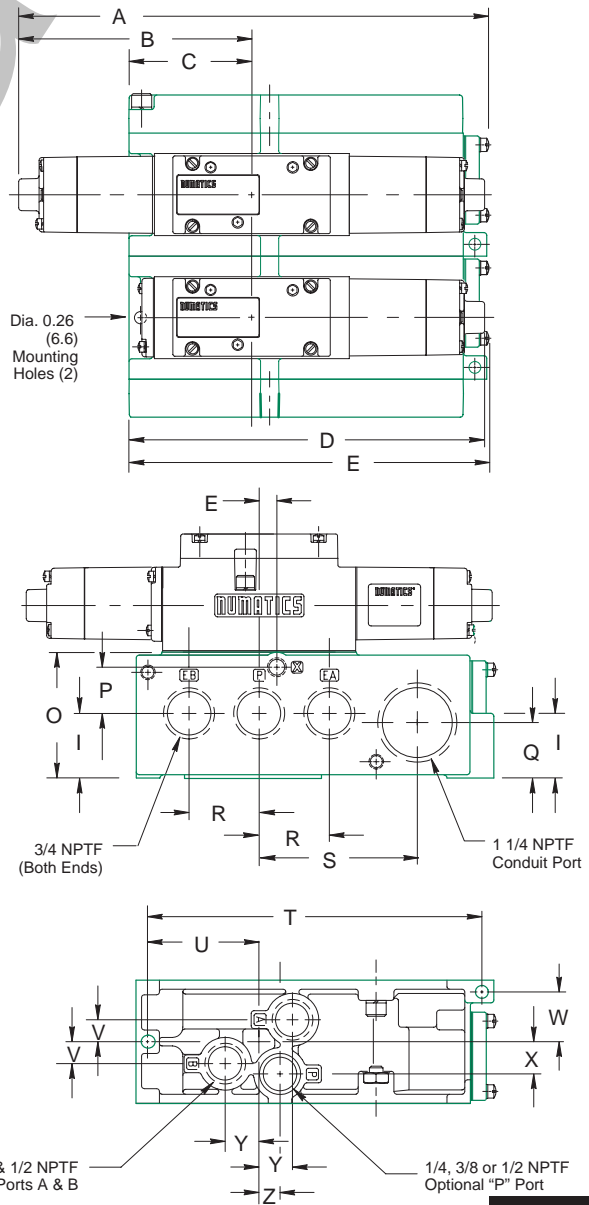
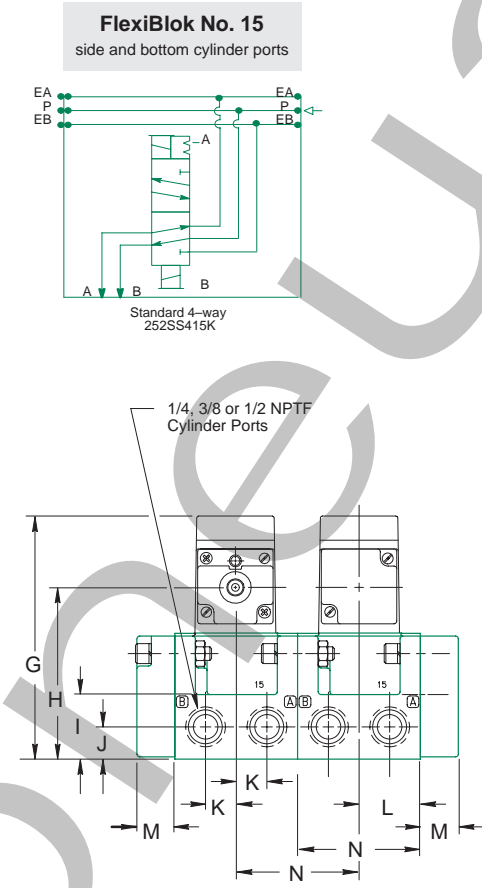

MARK 25

Mark 25 sandwich pressure regulator dimensions

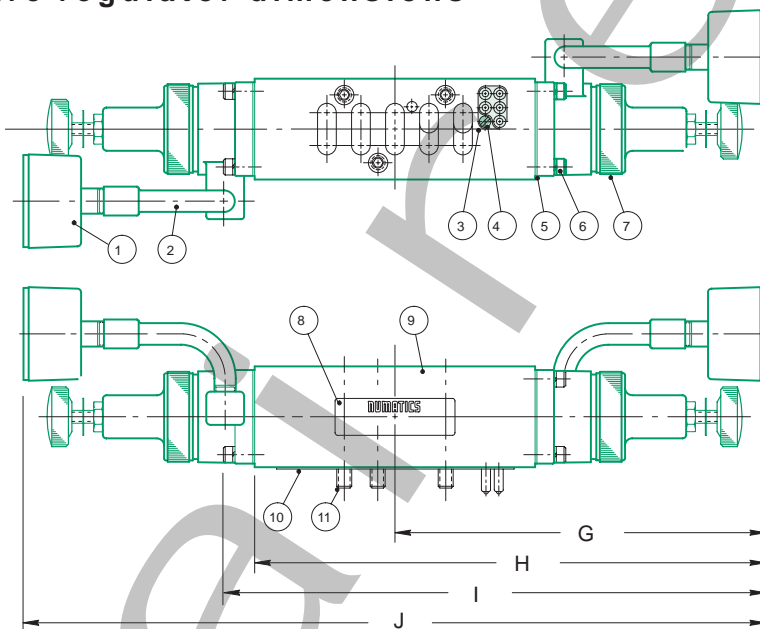
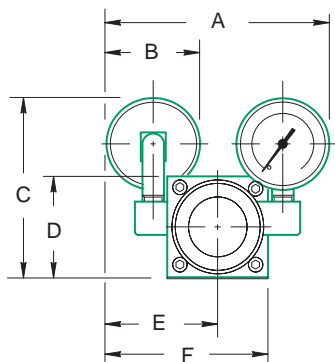

Dimensions										
A	B	C	D	E	F	G	H	I	J	
3.87	1.62	5.72	1.76	1.94	2.80	6.42	8.86	9.26	12.85	
(98)	(41.2)	(145.3)	(44.7)	(49.3)	(71.1)	(163.1)	(226)	(235.2)	(326.4)	

**Dual check assembly kits:** RC 239-533  
 (for converting RD into RC or RQ) RQ 239-537

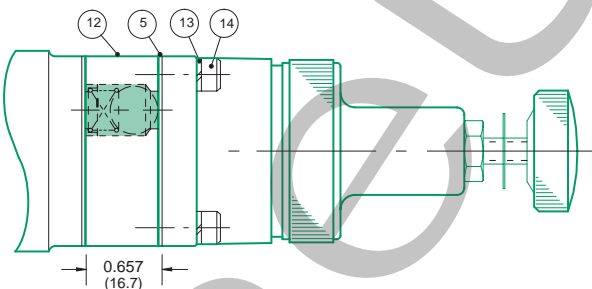

DET. NO.	NO. REQ'D.	PART NAME	PART NO.
1	*2	Gauge (See chart below)	
2	*2	Fitting (90° standard)	134-289
3	1	Plug-in Receptacle	230-324
4	1	Screw	127-342
5	**	Gasket (to regulator body)	113-272
6	-8	Screw	127-325
7	*2	Reg. Assembly (not sold separately)	
8	1	Nameplate	122-551
9	1	Regulator Block: RS RD, RC, RQ	125-581 125-578
10	1	Gasket (body to base)	113-417
11	3	Studs	127-329
12	2	Check Assembly (not sold separately)	
13	2	Hi-Collar Lockwasher (RC, RQ only)	128-144
14	8	Screw (RC, RQ only)	127-227

\* RS models require (1)  
 \*\* (1) for RS; (2) for RD; (4) for RC, RQ  
 - (4) for RS

MARK 25

Regulator service kit 229-640\*

End jumper plate kit 229-644

For Type RD regulators: add options "016n" or "016P" to regulator model number)

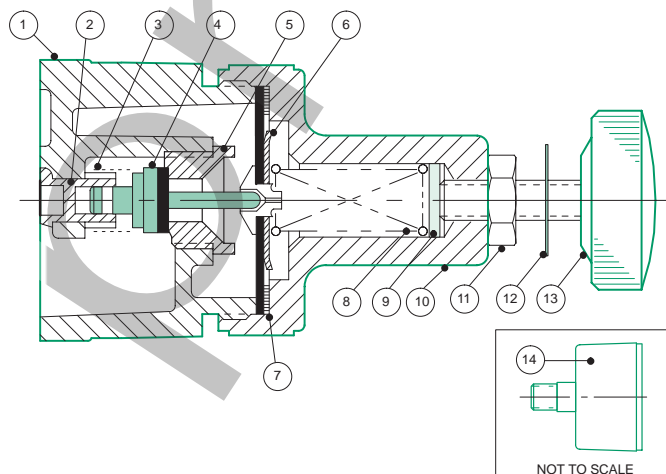

DET. NO.	NO. REQ'D.	PART NAME	Pressure Range PSIG		
			3-30	5-60	10-130
1	1	Reg. Assembly	(Not Sold Separately)		
* 2	1	Retainer	116-291	116-291	116-291
* 3	1	Spring	115-210	115-210	115-210
* 4	1	Poppet Assembly	221-121	221-121	221-121
* 5	1	Poppet Seat	124-142	124-142	124-142
* 6	1	Diaphragm Assembly	213-285	213-285	213-285
* 7	1	Washer	116-292	116-292	116-292
8	1	Bonnet Spring	115-211	115-212	115-213
* 9	1	Spring Guide	116-293	116-293	116-293
10	1	Bonnet	125-314	125-314	125-314
11	1	Locknut	128-177	128-177	128-177
12	1	Pressure Label	122-508	122-509	122-510
13	1	Knob Assembly	213-284	213-284	213-284
14	1	Regulator Gauges (with PSIG of . . .)	214-118 (0-60)	214-117 (0-100)	214-103 (0-160)
<b>Regulator Unit Kits</b> (includes regulator assembly, gaskets, and screws)			<b>229-641</b>	<b>229-642</b>	<b>229-643</b>

\* Indicates parts included in regulator service kit.



### Mark 25 base assembly kits

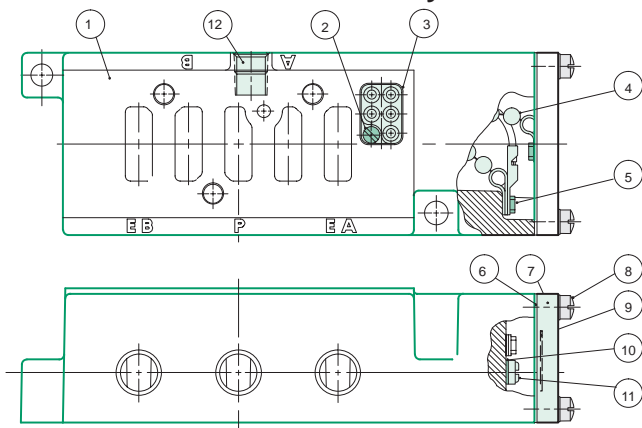

DET NO.	NO. REQ'D.	PART NAME	PART NO.
1	1	Base	103-717
2	1	Screw (receptacle)	127-342
3	1	Receptacle Assembly	230-324
4	1	Cover Chain	125-185
5	2	Screw	127-180
6	1	Gasket	113-265
7	1	Conduit Cover	105-240
8	1	Screw Assembly	127-296
9	1	Label	127-296
10	1	Washer	128-162
11	1	Screw	127-176
12	1	Pipe Plug:	1/4 NPTF 129-101 3/8 NPTF 129-102 1/5 NPTF 129-103 G 1/4 129-161 G 3/8 129-163 G 1/2 129-164

All parts listed are included in kit.

Base with plug-in receptacle	1/4 NPTF	3/8 NPTF	1/2 NPTF	G 1/4	G 3/8	G 1/2
3A: Side ports with individual exhaust	203-812	203-813	203-814	203-826	203-827	203-828

### Mark 25 FlexiBlok manifold kits

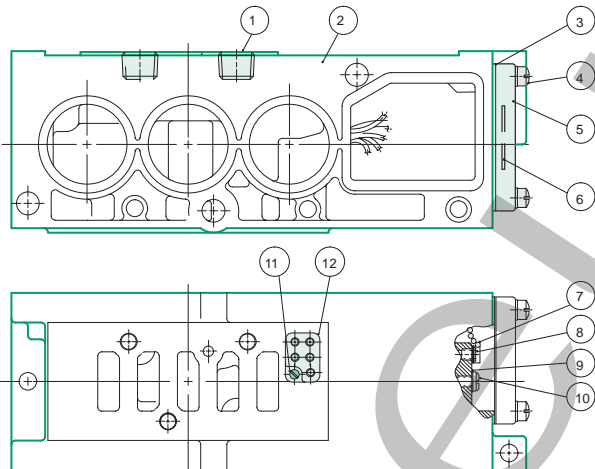

DET NO.	NO. REQ'D.	PART NAME	PART NO.
1	2	Pipe Plug:	1/4 NPTF 129-101 3/8 NPTF 129-102 1/5 NPTF 129-103 G 1/4 129-161 G 3/8 129-163 G 1/2 129-164
2	1	Valve Blok (not sold separately)	
3	1	Gasket	113-144
4	2	Screw Assembly	127-173
5	1	Conduit Cover	105-207
6	1	Label	122-355
7	1	Cover Shine	125-185
8	2	Screw	127-180
9	1	Washer	128-162
10	1	Screw	127-176
11	1	Screw (receptacle)	127-342
12	1	Receptacle Assembly	230-324

All parts listed are included in kit.

FlexiBlokmanifold	1/4 NPTF	3/8 NPTF	1/2 NPTF
15: manifold with side and bottom cylinder ports	239-598	239-599	239-600

### Mark 25 manifold accessory kits

#### End plate kits

NPTF 239-601

G Tap 239-646  
G galleries w/metric conduit

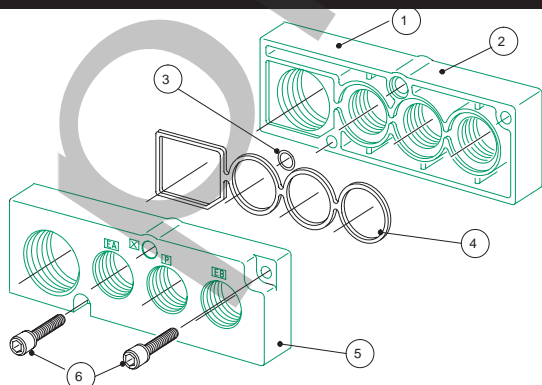

DET. NO.	NO. REQ'D	PART NAME	PART NUMBER	
			NPTF	G Tap metric conduit
1	1	Right End Plate	104-508	104-528
2	1	Nameplate	122-199	122-199
3	1	O-Ring	126-107	126-107
4	1	Gasket	113-298	113-298
5	1	Left End Plate	104-507	104-527
6	2	Screws	127-222	127-222

All parts listed are included in kit.

MARK 25

Mark 25 manifold accessory kits

Blank station plate kit 239-576

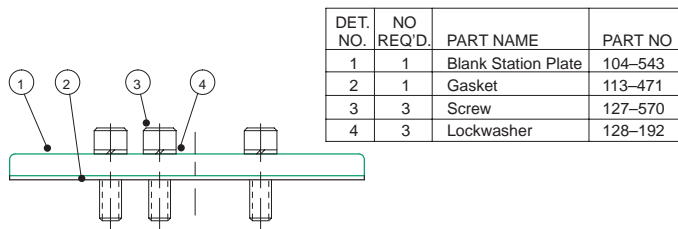

DET. NO.	NO. REQ'D.	PART NAME	PART NO.
1	1	Blank Station Plate	104-543
2	1	Gasket	113-471
3	3	Screw	127-570
4	3	Lockwasher	128-192

Blocking disc 124-160

For blacking any gallery in Mark 25 FlexiBlok manifolds.

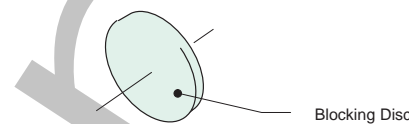

Mark 25 solenoid assemblies

Complete solenoid capsule assemblies

End cap only

includes solenoid and end cap assembly + screws and gaskets

Override Type	Valve Function	Plug-in Style	VOLTAGE				LIGHT OPTION					
			100-115/50 110-120/60	200-230/50 220-240/60	24/50-60	12 VDC	24 VDC	100-130V	200-260V	12VDC	24VDC	NO LIGHT
Flush non-locking override with light	2 position	Standard	237-325	237-326	237-426	226-800	226-801	204-217	204-218	204-491	204-492	204-216
	2 position	DIN plug-in	237-337	237-338	—	226-509*	226-510*	204-217	204-218	N/A	N/A	204-216
	3 position	Standard	237-331	237-332	237-425	226-804	226-805	204-220	204-221	204-495	204-496	204-219
	3 position	DIN plug-in	237-343	237-344	—	226-515*	226-516*	204-220	204-221	N/A	N/A	204-219

Solenoid only

less end cap; screws, gaskets NOT included.

Standard	228-702	228-707	228-708	225-371	225-372
DIN plug-in	228-694	228-695	228-696	225-265	225-266

\* DIN DC solenoids are not available with light.

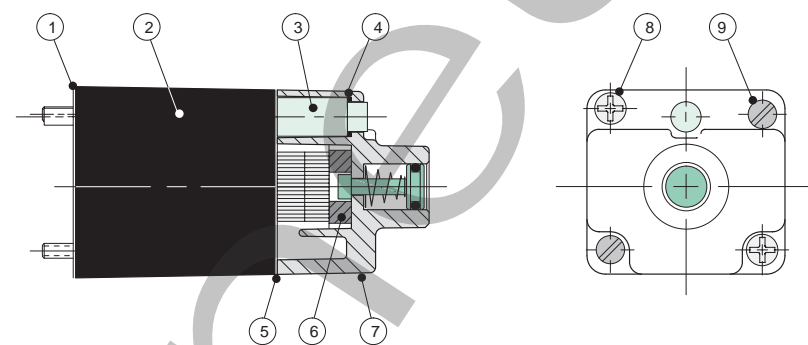

Flush Non-Locking Override with light (Standard)

Service parts

DET. NO.	NO. REQ'D.	PART NAME	PART NO.
1	1	Gasket (body to solenoid)	113-268
2	1	Solenoid	See Chart
3	1	Light Assembly: 110-115/50 110-120/60 200-230/50 220-240/60 12VDC 24 VDC	230-235 230-235 230-236 230-236 230-283 230-283 230-284
4	1	O-Ring Seal	126-144
5	1	Gasket (end cap to solenoid)	113-267
6	1	Bumper: Black for 2-Position Red for 3-Position	114-134 114-133
7	1	End Cap Assembly	See Chart
8	2	Screw (end cap to solenoid)	127-297
9	2	Screw (AC solenoid to body) Screw (DC solenoid to body)	127-298 127-302

MARK 25

Plug-in connector assemblies

Per DIN Spec. No. 43650  
Accepts cable dia. .310 to .410

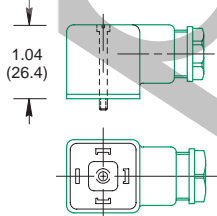

For DIN plug-in solenoid wiring options 6 and 4

Part Name	Part No.
Grey (A) Plug Assembly	230-369
Black (B) Plug Assembly	230-370
Plug with 24 VDC Light	230-371
Plug with 110 VAC Light	230-372
Plug with 220 VAC Light	230-373
Plug with 12 VDC Light	230-385

Superstructure plug connector with cord

Per DIN Spec. No. 43650  
For DIN plug-in solenoid wiring options 6 and 4

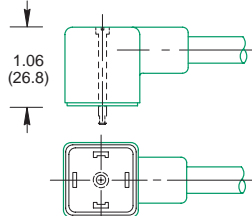

Part Name	Part No.
Plug with 4' Cord	230-213
Plug with 6" Cord	230-215

dimensions = inches  
(in parenthesis = mm)





Mark 25 valve service kits and parts — 2 position

Kit No. A12-K1\* (for models 252SA4, 253SA4, 254SA4)

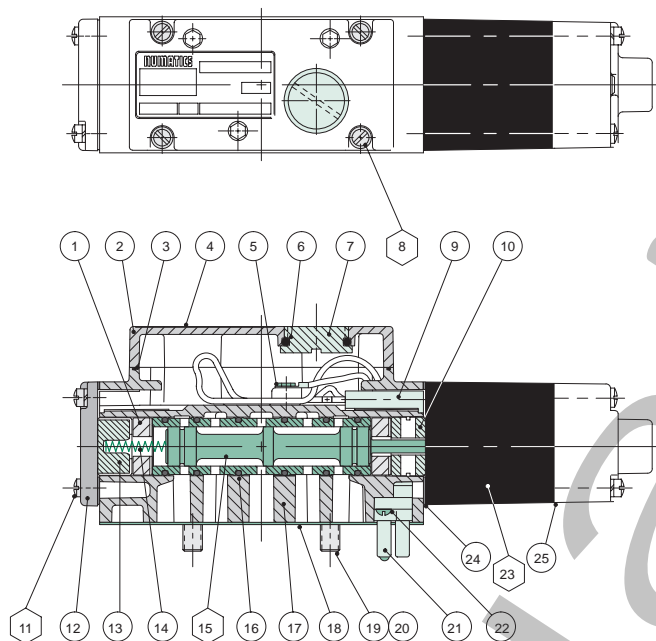

DET. NO.	NO. REQ'D.	PART NAME	PART NO.
* 1	2	Bumper	114-170
2	1	Conduit Cover	105-315
* 3	1	Gasket (Conduit Cover)	113-418
4	1	Nameplate	122-945
5	1	Screw	127-180
6	1	O-Ring	126-117
7	1	Plug	124-232
8	4	Screw Assembly	127-296
9	1	Receptacle Housing	125-309
* 10	1	Detent Body	110-113
11	2	Screw Assembly	127-326
12	1	Spring Cover	104-215
* 13	1	Spring Retainer	116-419
* 14	1	Spring	115-214
15	1	Sleeve Assembly with Seals	209-416
* 16	6	O-Ring Seals	126-204
17	1	Valve Body (not sold separately)	
* 18	1	Gasket (Body to Base)	113-417
19	3	Screw	127-120
20	3	Lockwasher	128-108
21	1	Plug Assembly	230-762
22	1	Screw	127-169
23	1	Solenoid Capsule Assembly	See Chart
* 24	2	Gasket (Body to Solenoid) (Body to Spring Cover)	113-268
* 25	1	Gasket (Sol. to End Cap)	113-267

\* Indicates parts included in service kit.

MARK 25

Kit No. A12-K2\* (for models 252SS4, 253SS4, 254SS4)

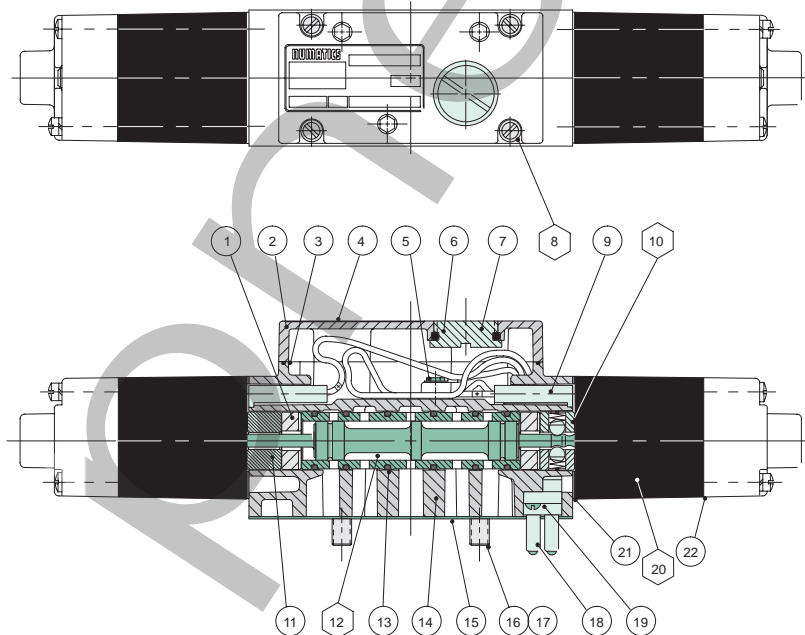

DET. NO.	NO. REQ'D.	PART NAME	PART NO.
* 1	2	Bumper	114-170
2	1	Conduit Cover	105-315
* 3	1	Gasket (Conduit cover)	113-418
4	1	Nameplate	122-945
5	1	Screw	127-180
6	1	O-Ring	126-117
7	1	Plug	124-232
8	4	Screw Assembly	127-296
9	2	Receptacle Housing	125-309
* 10	1	Detent Assembly	210-116
* 11	1	Spacer	116-420
12	1	Sleeve Assembly with Seals	209-415
* 13	6	O-Ring Seals	126-204
14	1	Valve Body (not sold separately)	
* 15	1	Gasket (Body to Base)	113-417
16	3	Screw	127-120
17	3	Lockwasher	128-108
18	1	Plug Assembly	230-763
19	1	Screw	127-169
20	2	Solenoid Capsule Assembly	See Chart
* 21	2	Gasket (Solenoid to Body)	113-268
* 22	2	Gasket (Sol. to End Cap)	113-267

\* Indicates parts included in service kit.

Spool and sleeve assemblies are precision matched sets; assemblies include (6) 126-204 seals; spools are not interchangeable.

Mark 25 valve service kits and parts — 3 position

Kit No. A12-K3\* (for models 252SS5, 253SS5, 254SS5)

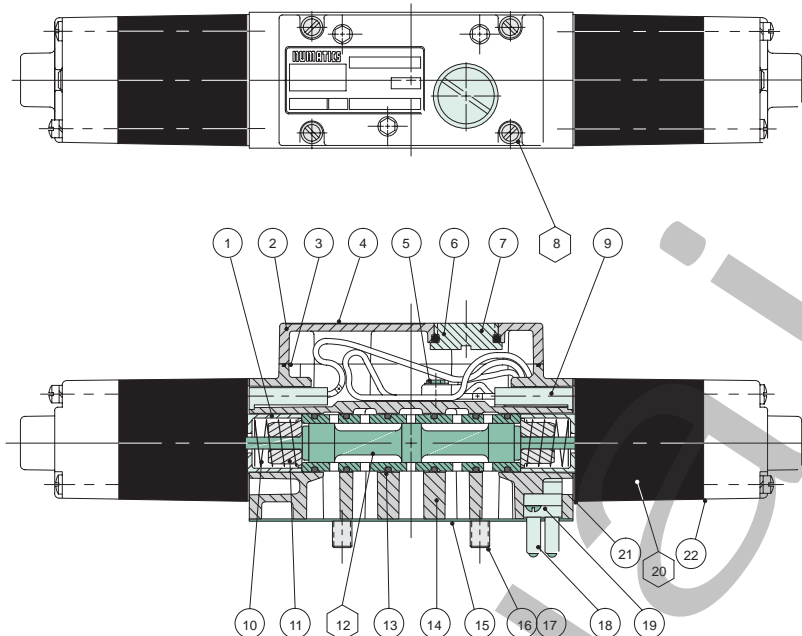

DET. NO.	NO. REQ'D.	PART NAME	PART NO.
* 1	2	Spacer	116-421
2	1	Conduit Cover	105-315
* 3	1	Gasket (Conduit Cover)	113-418
4	1	Nameplate	122-945
5	1	Screw	127-180
6	1	O-Ring	126-117
7	1	Plug	124-232
8	4	Screw Assembly	127-296
9	2	Receptacle Housing	125-309
* 10	2	Spring	115-290
* 11	2	Spring Retainer	116-391
12	1	Sleeve Assembly with Seals	209-414
* 13	6	O-Ring Seals	126-204
14	1	Valve Body (not sold separately)	
* 15	1	Gasket (Body to Base)	113-417
16	3	Screw	127-120
17	3	Lockwasher	128-108
18	1	Plug Assembly	230-763
19	1	Screw	127-169
20	2	Solenoid Capsule Assembly	See Chart
* 21	2	Gasket (Solenoid to Body)	113-268
* 22	2	Gasket (Sol. to End Cap)	113-267

\* Indicates parts included in service kit.

Kit No. A12-K3\* (for models 252SS6, 253SS6, 254SS6)

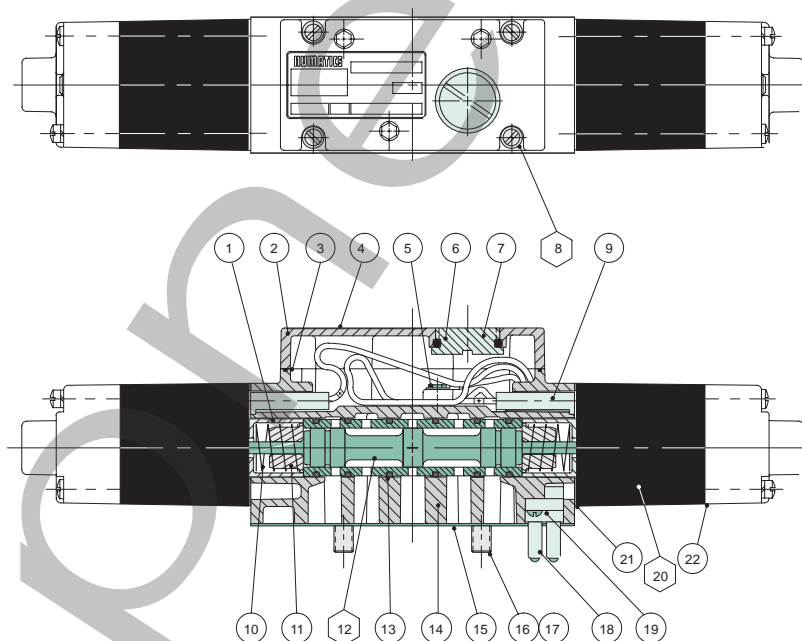

DET. NO.	NO. REQ'D.	PART NAME	PART NO.
* 1	2	Spacer	116-421
2	1	Conduit Cover	105-315
* 3	1	Gasket (Conduit Cover)	113-418
4	1	Nameplate	122-945
5	1	Screw	127-180
6	1	O-Ring	126-117
7	1	Plug	124-232
8	4	Screw Assembly	127-296
9	2	Receptacle Housing	125-309
* 10	2	Spring	115-290
* 11	2	Spring Retainer	116-391
12	1	Sleeve Assembly with Seals	209-413
* 13	6	O-Ring Seals	126-204
14	1	Valve Body (not sold separately)	
* 15	1	Gasket (Body to Base)	113-417
16	3	Screw	127-120
17	3	Lockwasher	128-108
18	1	Plug Assembly	230-763
19	1	Screw	127-169
20	2	Solenoid Capsule Assembly	See Chart
* 21	2	Gasket (Solenoid to Body)	113-268
* 22	2	Gasket (Sol. to End Cap)	113-267

\* Indicates parts included in service kit.

Spool and sleeve assemblies are precision matched sets; assemblies include (6) 126-204 seals; spools are not interchangeable.