

MARK Plus 6 SERIES

solenoid-pilot actuated valves





Mark Plus 6 solenoid-pilot actuated valves

TECHNICAL DATA	3
VALVE MODEL SELECTION	4
VALVE/BASE DIMENSIONS	5
FLEXIBLOK® MANIFOLDS	6-7
SANDWICH PRESSURE REGULATORS	8-9
REGULATOR KITS	10
ACCESSORY KITS	11-12
BASE ASSEMBLY KITS	13
FLEXIBLOK® MANIFOLD KITS	13
VALVE SERVICE KITS	14-15

MARK +6

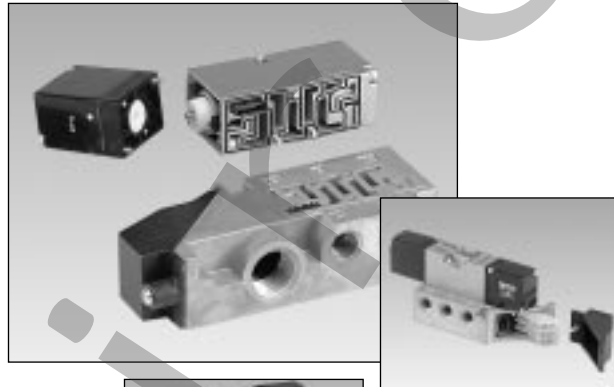

MARK Plus 6 PLUG-IN FEATURES:

Mark Plus 6 valves have a plug-in base or manifold, a plug-in solenoid-pilot, plug-in regulator, and an optional plug-in speed control sandwich. The unit to base electrical plug permits instant valve unit replacement without disconnecting piping or wiring.

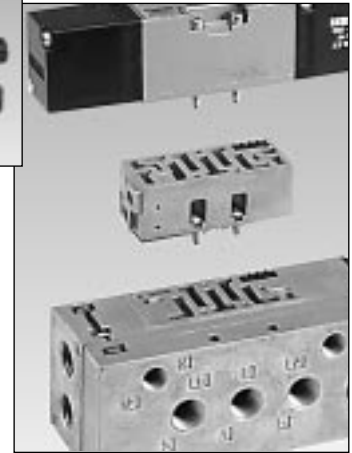

Time-proven lapped spool and sleeve assembly

Flush non-locking manual override

Pilot light indicates when power is supplied to solenoid

Plug-in solenoid-pilot provides fast response

Plug-in manifold with terminal block for wiring ease

Ultra lightweight magnesium alloy construction

Valve body integral recessed gasket provides positive sealing.

Valve unit to base integral plug

MK6-2

Mark Plus 6 valves

- solenoid pilot actuated
- lightweight magnesium alloy valve body
- plug-in solenoid with indicator light
- multi-purpose
- 5-ported, 4-way, 2 and 3 position
- lapped spool and sleeve assembly
- Cv to 0.6
- 1/8 and 1/4 NPTF or G Tap ports
- for unlubricated or lubricated service
- integral plug-in regulators available
- integral plug-in speed control with adjustments on the same end
- plug-in manifold with terminal block for ease of wiring
- optional push-in tubing connections on subbases and manifolds
- NEMA 4

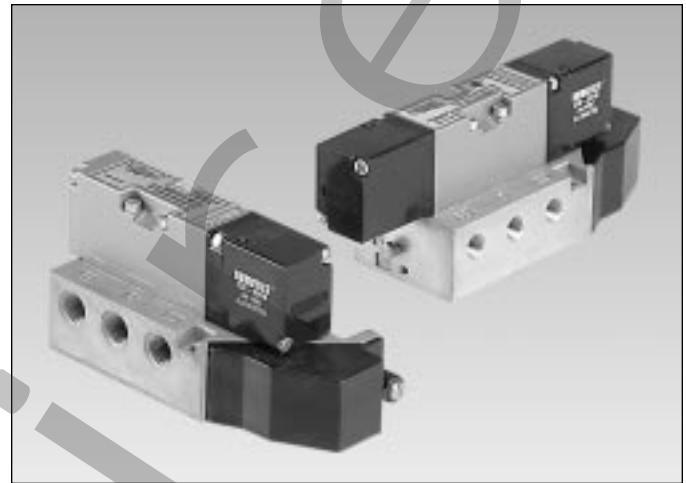

MARK +6



Technical data

Valve Data	NPTF		G tap	
Cv:	1/8 = 0.6	1/4 = 0.6	1/8 = 0.6	1/4 = 0.6
Flow Capacity:	28 SCFM @ 80 PSIG upstream pressure to atmosphere		591 NI/m @ 6 Bar upstream/5 Bar downstream	
Operating Pressure Range:	28" Hg. Vacuum to 150 PSIG		Vacuum to 10 Bar	
Temperature Range:	-10 F to +115 F ambient		-23 C to +46 C ambient	
Pilot Pressure Range:	14.5 to 120 PSIG		1 to 8.23 Bar	

Operating data

All solenoids are continuous duty rated.	24VDC		110 V AC / 50 Hz. to 120 V AC/ 60 Hz.	
Power (Watts)	2.5 W		4.2 W	
Holding Current (Amps.)	0.15 amps		0.03 amps	
Response Times in Seconds:	Energize	De-energize	Energize	De-energize
2-Position, Single, Spring Return	0.010 sec.	0.024 sec.	0.010 sec.	0.024 sec.
2-Position, Double, Detented	0.010 sec.	not applicable	0.010 sec.	not applicable
3-Position, Spring Centered	0.011 sec.	0.031 sec.	0.011 sec.	0.031 sec.



Mark Plus 6 model selection table (standard valve/mounting combinations)

Valve Function	Port Size	AC or DC**	Individual base with side ports and individual exhaust		FlexiBlok manifold with side & bottom cylinder ports *NOTE: manifolds with push-in fittings are available with side ports only	
			without speed control	with speed control	without speed control	with speed control
UNIT ONLY 061BA400K (AC) 061BA400M (DC)	1/8	AC	061BA43AK	061BA43CK	061BA415K	061BA425K
	1/8	DC	061BA43AM	061BA43CM	061BA415M	061BA425M
	1/4	AC	062BA43AK	062BA43CK	062BA415K	062BA425K
	1/4	DC	062BA43AM	062BA43CM	062BA415M	062BA425M
	1/4 w/push-in*	AC	062BA43AKL	062BA43CKL	062BA411KL*	062BA421KL*
	1/4 w/push-in*	DC	062BA43AML	062BA43CML	062BA411ML*	062BA421ML*
UNIT ONLY 061BB400K (AC) 061BB400M (DC)	1/8	AC	061BB43AK	061BB43CK	061BB415K	061BB425K
	1/8	DC	061BB43AM	061BB43CM	061BB415M	061BB425M
	1/4	AC	062BB43AK	062BB43CK	062BB415K	062BB425K
	1/4	DC	062BB43AM	062BB43CM	062BB415M	062BB425M
	1/4 w/push-in*	AC	062BB43AKL	062BB43CKL	062BB411KL*	062BB421KL*
	1/4 w/push-in*	DC	062BB43AML	062BB43CML	062BB411ML*	062BB421ML*
UNIT ONLY 061BB500K (AC) 061BB500M (DC)	1/8	AC	061BB53AK	061BB53CK	061BB515K	061BB525K
	1/8	DC	061BB53AM	061BB53CM	061BB515M	061BB525M
	1/4	AC	062BB53AK	062BB53CK	062BB515K	062BB525K
	1/4	DC	062BB53AM	062BB53CM	062BB515M	062BB525M
	1/4 w/push-in*	AC	062BB53AKL	062BB53CKL	062BB511KL*	062BB521KL*
	1/4 w/push-in*	DC	062BB53AML	062BB53CML	062BB511ML*	062BB521ML*
UNIT ONLY 061BB600K (AC) 061BB600M (DC)	1/8	AC	061BB63AK	061BB63CK	061BB615K	061BB625K
	1/8	DC	061BB63AM	061BB63CM	061BB615M	061BB625M
	1/4	AC	062BB63AK	062BB63CK	062BB615K	062BB625K
	1/4	DC	062BB63AM	062BB63CM	062BB615M	062BB625M
	1/4 w/push-in*	AC	062BB63AKL	062BB63CKL	062BB611KL*	062BB621KL*
	1/4 w/push-in*	DC	062BB63AML	062BB63CML	062BB611ML*	062BB621ML*

* **Push-In Fitting Options:** Accepts 1/4" tube diameter only. Push-in fittings are not available on FlexiBlok manifolds with bottom cylinder ports.

** Specify volts and Hz. after the model number.

G tap options: For G tap ports, add a "G" to the model number.
EXAMPLES: 061BB43AMG

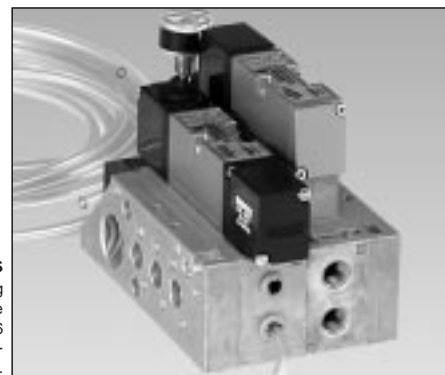

Push-In Fittings
 Optional push-in tubing connections are available for use with Mark Plus 6 individual bases or FlexiBlok manifolds.

MARK +6

Mark Plus 6 valve & base dimensions

061BA4 single direct solenoid actuated valve
 061BB4, 5, 6 double direct solenoid actuated valve (shown in phantom)
 Base 1/8 or 1/4 NPTF or G tap side ports
 1/2 NPTF conduit port connection

Dimensions

A	1.37 (35)
B	1.67 (42.4)
C	0.44 (11)
D	0.80 (20.2)
E	0.62 (16)
F	6.53 (166)
G	5.35 (136)
H	1.19 (30)
I	0.81 (20.6)
J	0.81 (20.6)
K	1.44 (36.5)
L	0.97 (24.6)
M	0.54 (14)
N	0.20 (5.2)
O	0.17 (4.2)
P	1.02 (26)
Q	2.05* (52)
R	0.80 (20)
S	0.88 (22)
T	1.00 (25.4)
U	2.63 (67)
V	1.25 (32)
W	0.57 (14.4)
X	0.25 (6.4)
Y	0.63 (16)

dimensions = inches
(in parenthesis = mm)

* 2.28 (58) for bases with
1/4 Push-In inserts

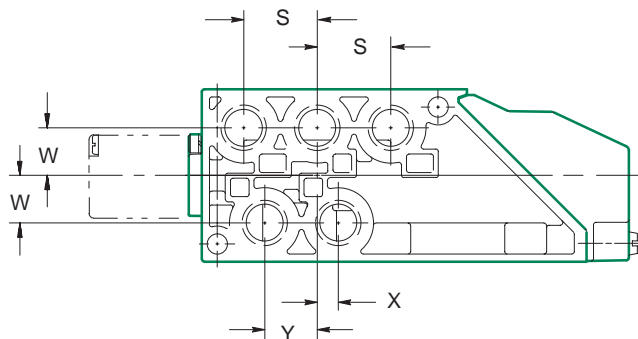
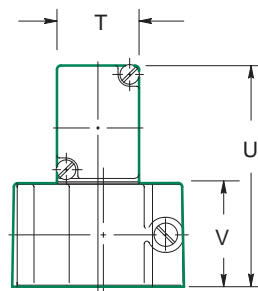
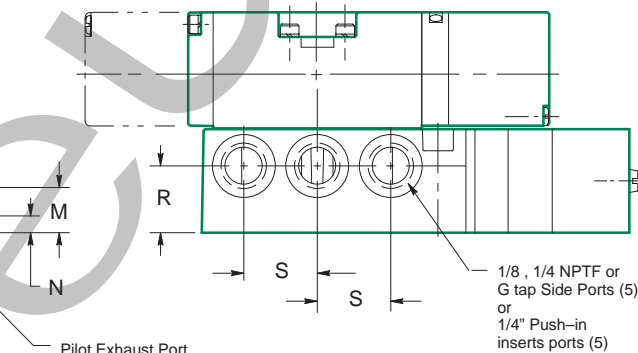
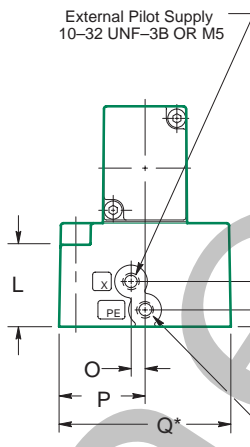
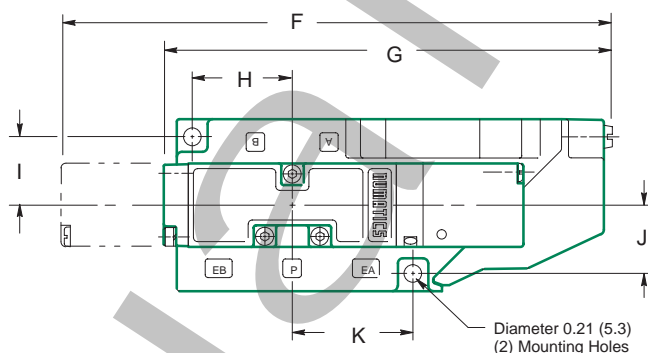
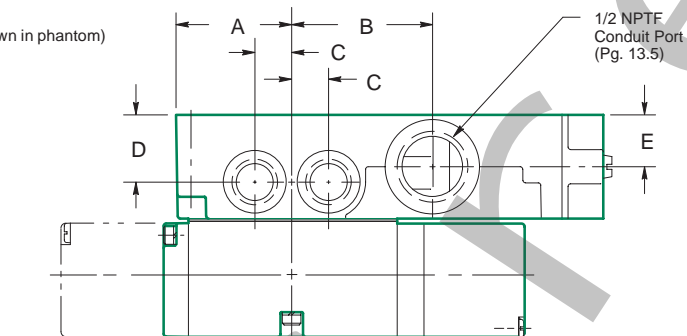

External Pilot Supply Instructions for sub-base mounting

- 1) Remove valve unit from sub-base mounting.
- 2) Remove the 10-32 or M5 plug from the X port.
- 3) Install M3 allen set screw (part no. 127-693) in the P-gallery of base. (see below)
- 4) Re-attach valve unit to the sub-base.
- 5) Install 10-32 UNF or M5 fitting into X-Port for pilot pressure supply.

NOTE: Pilot exhaust port PE must not be plugged or restricted in any way.

M3 Pilot Port Location

MARK +6



Mark Plus 6 FlexiBlok manifolds

- plug-in manifold with terminal block for ease of wiring
- 1/8, 1/4 NPTF or G tap side and bottom ports
- push-in fittings for 1/4" tube diameter
- ultra lightweight magnesium alloy construction
- stackable manifold mounting
- end plate tapped, both ends
- integral plug-in speed control with adjustments on same end
- NEMA 4

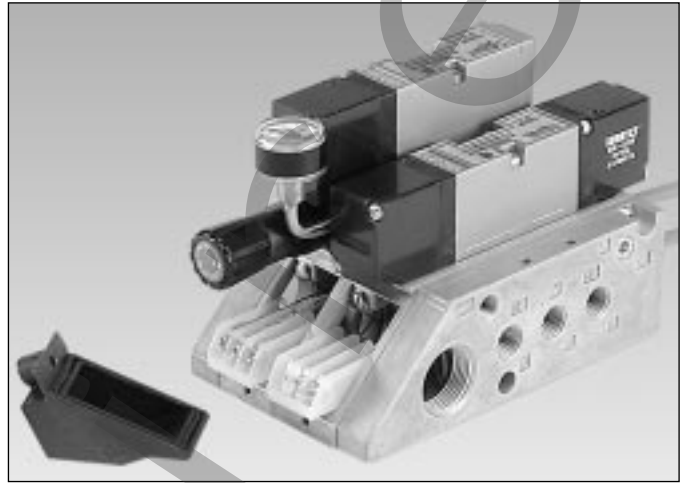

MARK +6

How to order

List in order, left to right, facing cylinder ports A and B. A typical 2-station manifold may be listed as follows:

Assembly Kit:* **AK061-2**
Station 1: **062BB425K 120/60**
Station 2: **062BA415K 120/60**
ASSEMBLED

If a blocking plug is required between two units, you must indicate which gallery it is to be installed.

*

AK061- + No. of Stations + Port Type — [Blank = NPTF galleries
G = G tap galleries/metric conduit
C = G tap galleries/NPTF conduit

Assembly kits are for factory assembled units only. Kits consist of end plates, and screw assemblies; and also include assembly and testing of the entire FlexiBlok manifold for proper operation. Due to flow, wiring, and practical assembly limitations, a maximum of 12 stations per assembly is recommended.

External pilot manifold block option:

To convert any valve mounted on a manifold to external pilot supply, it is not necessary to remove the valve from the manifold. All modifications are made to the manifold block. All blocks are shipped with internal pilot supply (M5 Allen hex screw plugging external port). To convert to external pilot supply take the M5 screw out of the external port and put into the internal port.

The left end plate X port is supplied from Numatics plugged. This plug may require removal based upon your external pilot supply requirements.

IMPORTANT NOTE: The pilot exhaust port, PE, must not be plugged or restricted in any way.

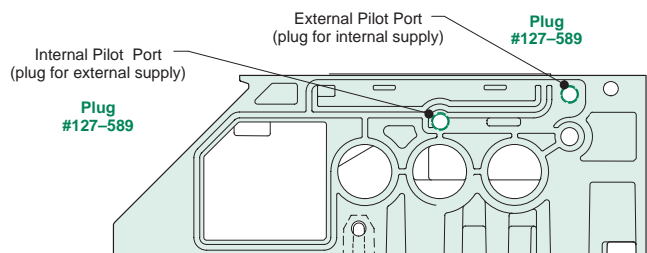
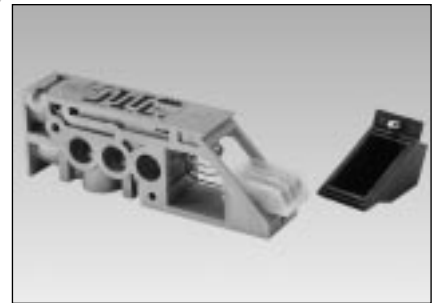

Mark Plus 6 FlexiBlok assembly dimensions

Mark Plus 6 manifold block shown with speed control

Dimensions	
A	0.91 (23)
B	0.42 (11)
C	1.06 (27)
D	1.54 (39)
E	4.31 (109)
F	2.77 (70)
G	5.49 (139)
H	4.28 (109)
I	4.38 (110)
J	2.05 (52)
K	0.96 (24.4)
L	3.44 (87)
M	0.88 (22.2)
N	0.38 (9.5)
O	0.64 (16.3)
P	0.61 (16)
Q	1.22 (31)
R	0.71 (18)
S	0.96 (24.4)
T	0.78 (20)
U	0.03 (0.76)
V	0.91 (23)
W	1.43 (36)
X	1.36 (34.5)
Y	2.32 (59)
Z	2.12 (54)
AA	0.65 (16.4)
BB	0.17 (4.2)
CC	0.19 (4.8)
DD	0.17 (4.2)
EE	1.46 (37.2)

dimensions = inches
(in parenthesis = mm)

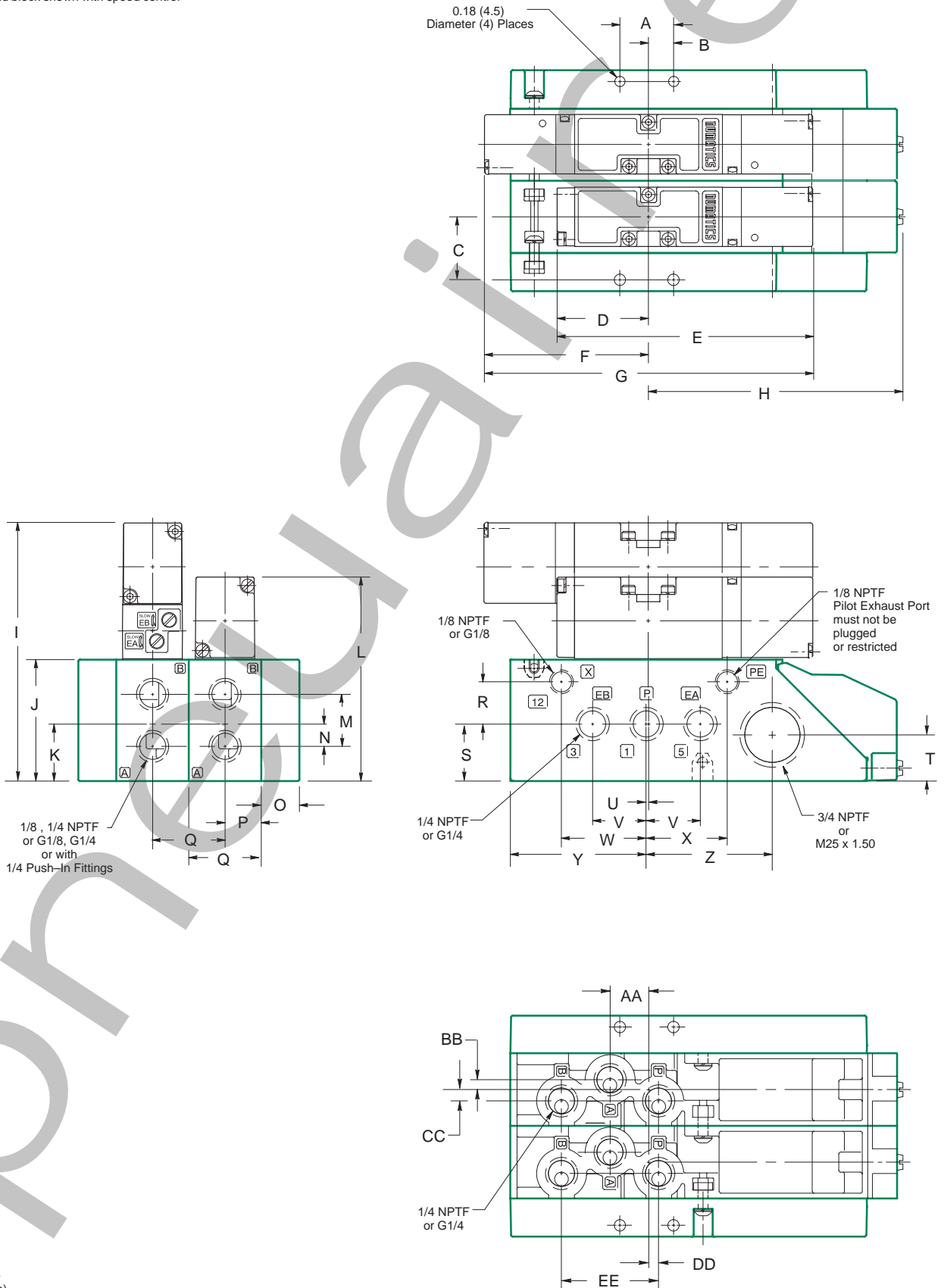

MARK +6



Mark Plus 6 sandwich pressure regulators

Types: RS / RD

When ordering a valve plus regulator mounted on a base or manifold, list the valve unit—only model number and include the mounting requirements within the regulator model selection. Specify “Assembled.”

Example orders:

	TYPE RS	TYPE RD
Valve unit only:	061BA400K 120/60	061BA400K 120/60
Regulator + mounting	061RS73AJL ASSEMBLED	062RD711JL ASSEMBLED



TYPE
RS

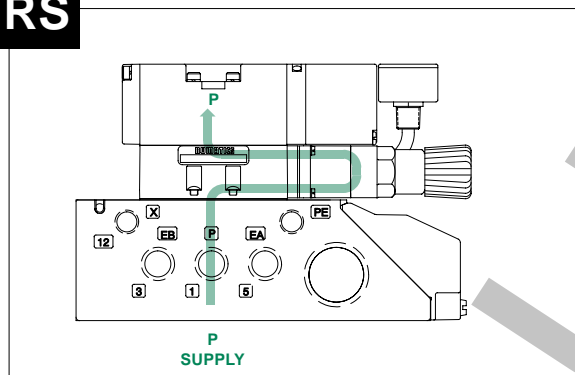

Single pressure from a single supply.

Dual pressure from a single supply.

TYPE
RD

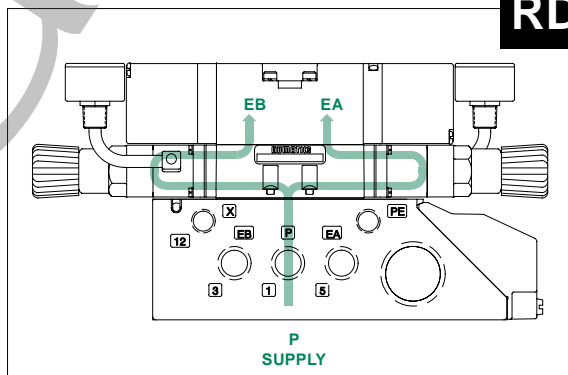

Mark Plus 6 regulator model selection table (standard regulator/mounting combinations)

Regulator Function	Port Size	Individual base with side ports and individual exhaust		FlexiBlok manifold with side cylinder ports		FlexiBlok manifold with side and bottom cylinder ports	
		0 – 30 PSIG	0 – 100 PSIG	0 – 30 PSIG	0 – 100 PSIG	0 – 30 PSIG	0 – 100 PSIG
Type RS	1/8	061RS33AJ	061RS73AJ	061RS311J	061RS711J	061RS315J	061RS715J
	1/4	062RS33AJ	062RS73AJ	062RS311J	062RS711J	062RS315J	062RS715J
UNIT ONLY 061RS300J	1/4 w/push-in*	062RS33AJL	062RS73AJL	062RS311JL	062RS711JL	N/A*	N/A*
Type RS** with speed control	1/8	061RS33CJ	061RS73CJ	061RS321J	061RS721J	061RS325J	061RS725J
	1/4	062RS33CJ	062RS73CJ	062RS321J	062RS721J	062RS325J	062RS725J
	1/4 w/push-in*	062RS33CJL	062RS73CJL	062RS321JL	062RS721JL	N/A*	N/A*
Type RD	1/8	061RD33AJ	061RD73AJ	061RD311J	061RD711J	061RD315J	061RD715J
	1/4	062RD33AJ	062RD73AJ	062RD311J	062RD711J	062RD315J	062RD715J
UNIT ONLY 061RD300J	1/4 w/push-in*	062RD33AJL	062RD73AJL	062RD311JL	062RD711JL	N/A*	N/A*

G tap options: For G tap ports, add a “G” to the model number. **EXAMPLES: 061RS73AJG**

* **Push-in Fittings:** Accepts 1/4” tube diameter only. Push-in fittings are not available on FlexiBlok manifolds with bottom cylinder ports.

** Speed control can only be used with TYPE RS. These model numbers include plug-in speed control + regulator + mounting. For more complete information on ordering with speed control, see page 10.

MK6-8

Mark Plus 6 sandwich pressure regulator dimensions

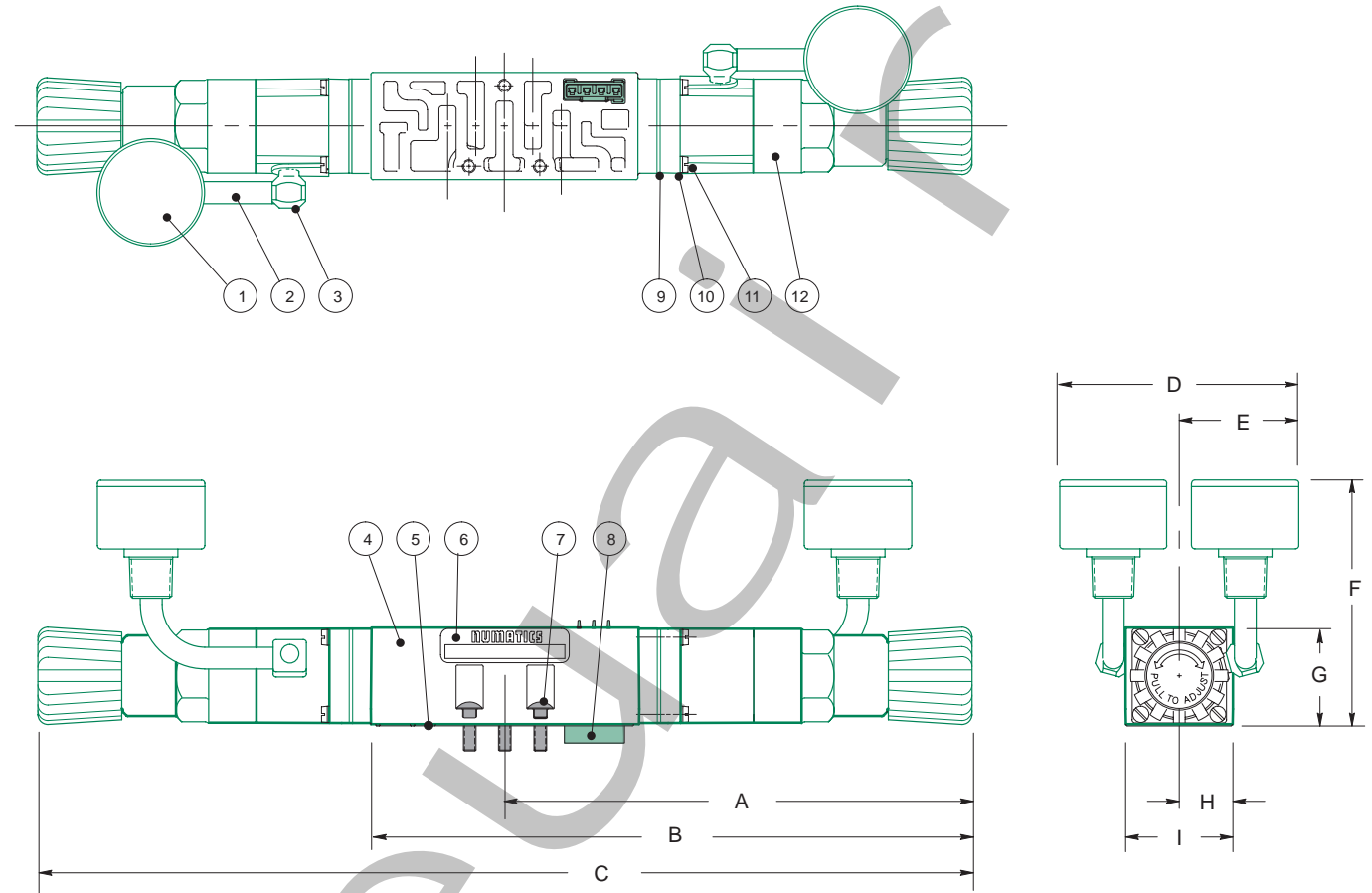

Dimensions

	A	B	C	D	E	F	G	H	I
--	---	---	---	---	---	---	---	---	---

inches	4.38	5.80	8.76	2.14	1.07	2.28	.90	.50	1.00
(mm)	(111.2)	(147.3)	(222.5)	(54.4)	(27.2)	(57.9)	(22.9)	(12.7)	(25.4)

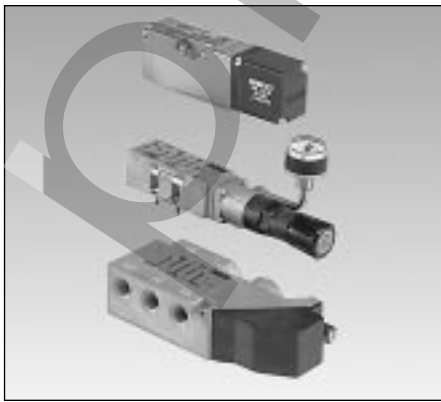

DET. NO.	NO. REQ'D.	PART NAME	PART NO.
1	*2	Gauge	214-209
2	*2	Tube Fitting	134-469
3	*2	Fitting	134-472
4	1	Regulator Block: RS RD	125-615 125-616
5	1	Gasket (body to base)	113-464
6	1	Nameplate	122-991
7	3	Screw	127-705
8	1	Plug Receptacle Assembly	230-725
9	1	Gasket (to regulator block)	113-472
10	**8	Lockwasher	128-172
11	**8	Screw	127-380
12	*2	Regulator Assembly (not sold separately)	

* (1) required for RS
** (4) required for RS



Mark Plus 6 valve/speed control/regulator plug-in assembly

MARK +6

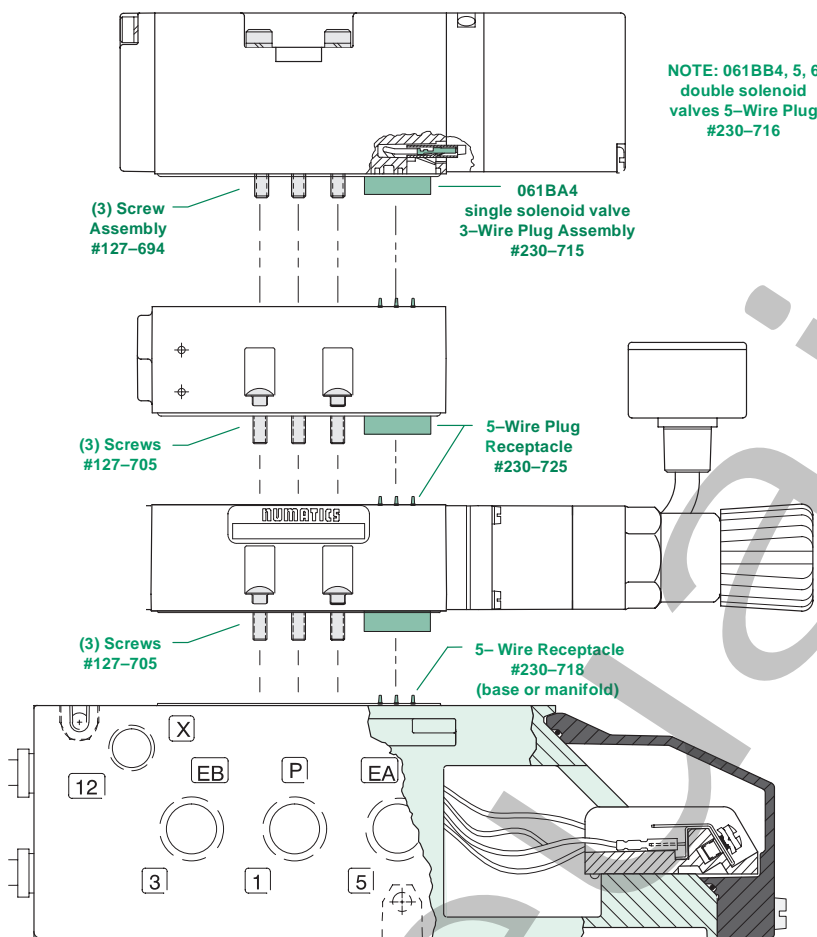

NOTE: 061BB4, 5, 6 double solenoid valves 5-Wire Plug #230-716

EXAMPLE

061BA400K

Mark Plus 6 single solenoid valve unit with plug-in assembly

062RS721JL

Single pressure regulator Type RS + speed control sandwich mounted on a 1/4 NPTF FlexiBlok manifold with side ports and push-in fittings.

EXAMPLE ORDER:

Valve: **061BA400K 120/60**
 Regulator: **062RS721JL ASSEMBLED**

Mark Plus 6 regulator kits & service parts

Regulator service kit 239-708

(includes all parts marked with an *)

Regulator unit kit (0-30 PSIG) 239-790

(includes regulator assembly, gaskets, screws) (0-100 PSIG) 239-707

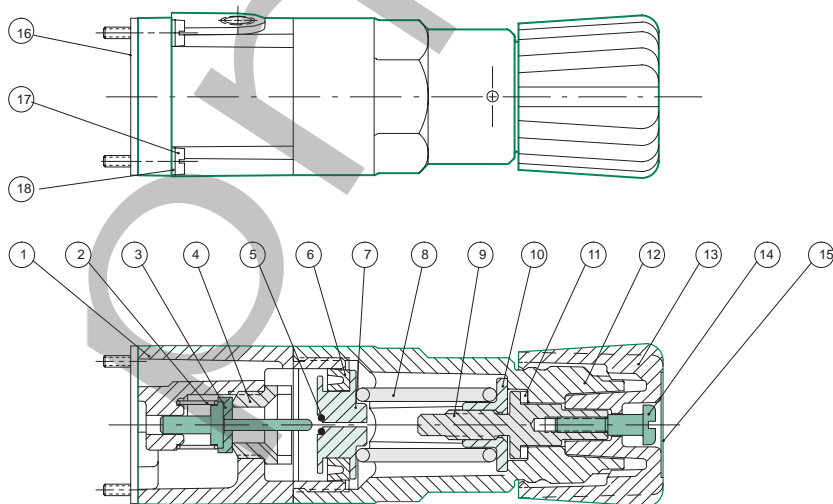

DET NO.	NO. REQ'D.	PART NAME	PART NO.
1	1	Regulator Body	101-631
* 2	1	Spring	115-226
* 3	1	Poppet Assembly	221-168
4	1	Poppet Seat	124-148
* 5	1	O-Ring	126-336
* 6	1	Seal U-Packing	124-302
7	1	Piston	125-618
8	1	Spring 0-30 PSIG 0-100 PSIG	115-352 115-342
9	1	Metering Screw	118-187
10	1	Spring Guide	112-369
* 11	1	Bearing	125-617
12	1	Bonnet	125-623
13	1	Knob	125-624
14	1	Screw	127-706
15	1	Label	122-992
* 16	1	Gasket	113-472
17	4	Screw	127-380
18	4	Lockwasher	128-172

Mark Plus 6 manifold accessory kits

End plate kits

1/4 NPTF 239-691

G 1/4 239-692

G 1/4 239-727

G galleries with M25 metric conduit

G galleries with 3/4 NPTF conduit

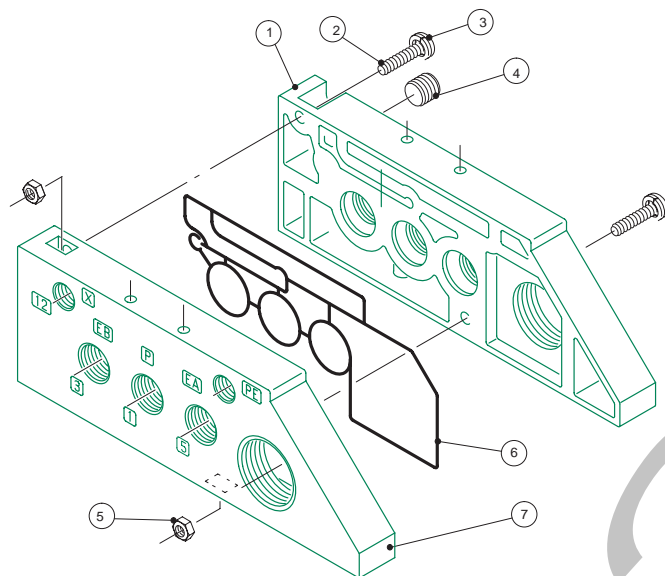

DET. NO.	NO. REQ'D	PART NAME	PART NUMBER		
			NPTF	G Tap metric conduit	G Tap NPTF conduit
1	1	Left End Plate	104-517	104-519	104-553
2	2	Screw	127-697	127-697	127-697
3	2	Lockwasher	128-279	128-279	128-279
4	1	Pipe Plug	129-100	129-160	129-160
5	2	Nut	128-191	128-191	128-191
6	1	Gasket	113-466	113-466	113-466
7	1	Right End Plate	104-518	104-520	104-554

MARK +6

Blank station plate kit 239-668

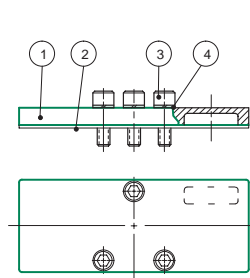

DET. NO.	NO. REQ'D	PART NAME	PART NO.
1	1	Blank Station Plate	104-543
2	1	Gasket	113-471
3	3	Screw	127-570
4	3	Lockwasher	128-192

Blocking disc kit 239-667

(used to block P gallery)

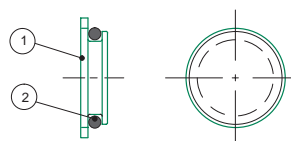

DET. NO.	NO. REQ'D	PART NAME	PART NO.
1	1	Blocking Disc	124-301
2	1	O-ring Seal	126-382

Speed control kit with plug

239-687

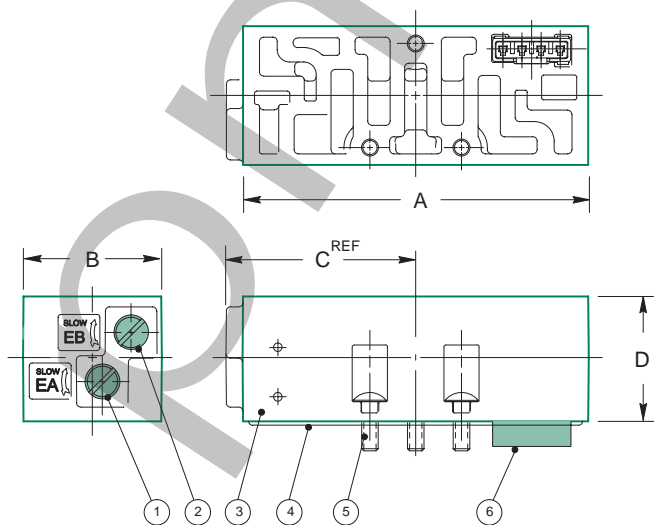

DET. NO.	NO. REQ'D	PART NAME	PART NO.
1	1	Metering Screw	118-184
2	1	Metering Screw	118-185
not shown	2	Nylon Rod for used w/metering screws	125-613
3	1	Speed Control Body (not sold separately)	
4	1	Gasket	113-464
5	3	Screw	127-705
6	1	Plug Receptacle Assembly	230-725

Dimensions

	A	B	C	D
inches	2.50	1.01	1.37	0.90
(mm)	(13.5)	(25.7)	(35)	(23)



Mark Plus 6 accessory kits (continued)

Adaptor kits with end plates

Mark 6 LEFT* of Mark 15 (NPTF) **239-766**

includes Kit #239-791 (Mark +6 left adaptor, screws, seals)
+ Mark 6 left end plate & Mark 15 right end plate

Mark 6 RIGHT* of Mark 15 (NPTF) **239-767**

includes Kit #239-792 (Mark +6 right adaptor, screws, seals)
+ Mark 6 right end plate & Mark 15 left end plate

* left/right when viewed from the cylinder ports of assembly

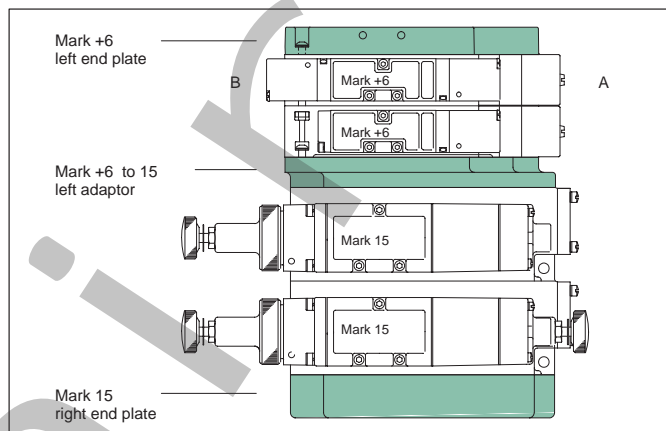

MARK +6

Terminal block kit **230-719**

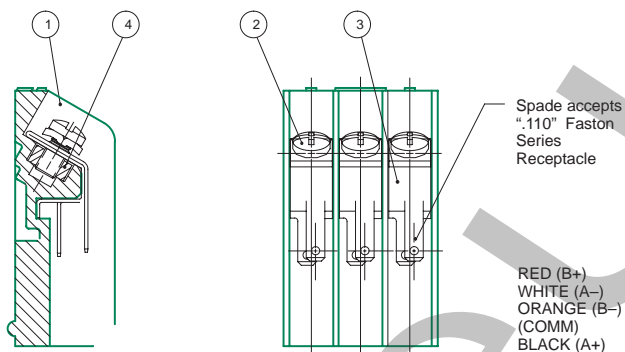

DET NO.	NO. REQ'D.	PART NAME	PART NO.
1	1	Terminal Block	140-580
2	3	Screw	127-689
3	3	Terminal Clip	140-556
4	3	Nut	128-281

Solenoid-pilot assemblies

Override Description	120/60 V AC	24 VDC
Flush non-locking override w/light (standard)	237-881	236-231
Flush locking override w/light (add option "011B" to valve no.)	237-880	236-230

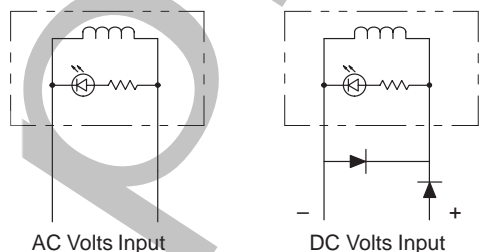
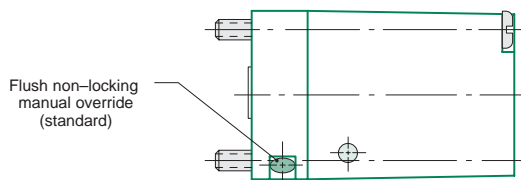

Solenoid Wiring

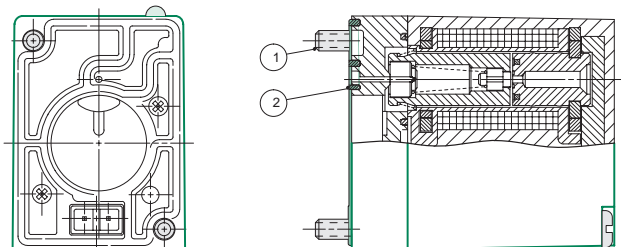

DET NO.	NO. REQ'D.	PART NAME	PART NO.
1	2	Screw	127-774
2	1	Gasket	113-465

Mark Plus 6 base assembly kits

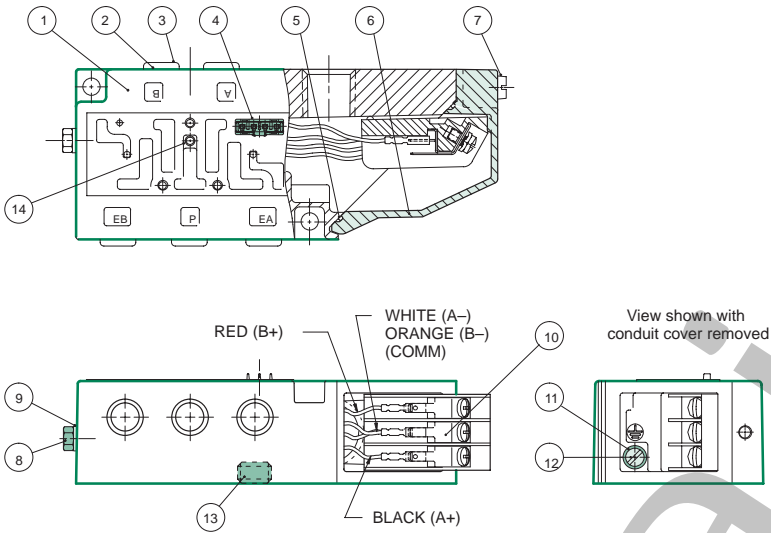

DET NO.	NO. REQ'D.	PART NAME	NPTF PART NO.	G TAP PART NO.
1	1	Base (not sold separately)		
**2	5	Tube Cartridge	134-458	134-458
**3	5	Manual Release Button	123-179	123-179
4	1	Plug-in Receptacle	230-718	230-718
5	1	Gasket	113-463	113-463
6	1	Conduit cover	105-339	105-339
7	1	Screw	127-692	127-692
*8	1	Plug	129-127	127-362
*9	1	Gasket	OMIT	113-311
10	1	Terminal Block Assembly	230-719	230-719
11	1	Cup Washer	128-162	128-162
12	1	Screw	127-176	127-176
13	5	Pipe Plug:	1/8 129-100 1/4 129-101	129-160 129-161
14	1	Plug (M3):	127-693	127-693

* Details 8 & 9 omitted on external pilot option.
 ** 1/4 push-in ports (5)—Base Kits #203-852 & 203-866 only.
 ~ Used on Bases w/side & bottom ports, individual exhaust only.
 Used only with external pilot supply option

Base Description	1/8 NPTF	1/4 NPTF	G 1/8	G 1/4	1/4 Push-In
3A & 3C Bases: side ports only, individual exhaust	203-854	203-853	203-856	203-855	203-852
3B & 3D Bases: side & bottom ports, individual exhaust	203-858	203-857	203-860	203-859	N/A
3A + external pilot option	203-868	203-867	203-870	203-869	203-866
3B + external pilot option	203-872	203-871	203-874	203-873	N/A

Mark Plus 6 FlexiBlok manifold kits

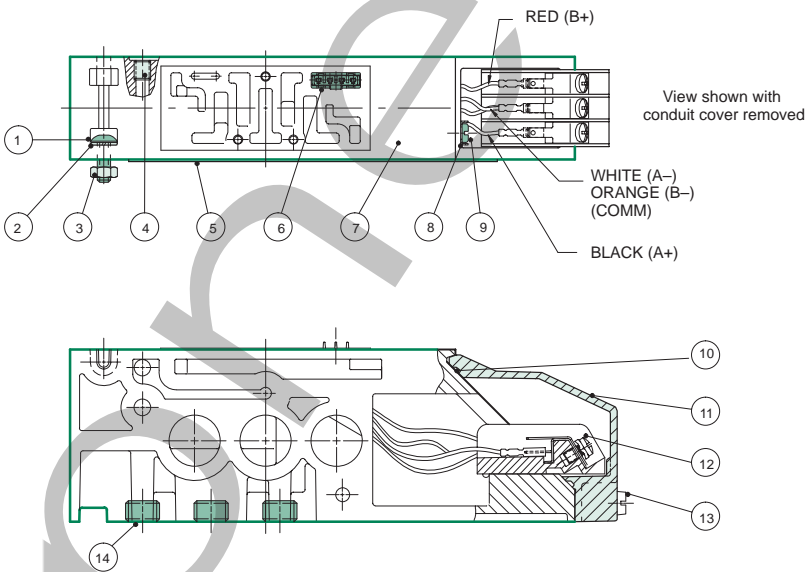

DET NO.	NO. REQ'D.	PART NAME	PART NO.
1	2	Screw	127-697
2	2	Lockwasher	128-279
3	2	Nut	128-191
4	1	Plug (M5 external pilot)	127-589
5	1	Gasket	113-466
6	1	Plug-in Receptacle	230-718
7	1	Manifold Block (not sold separately)	
8	1	Cup Washer	128-162
9	1	Screw	127-176
10	1	Gasket	113-463
11	1	Conduit Cover	105-339
12	1	Terminal Block Assembly	230-719
13	1	Screw	127-692
14	2	Plug:	1/8 NPTF 129-100 1/4 NPTF 129-101 G 1/8 129-160 G 1/4 129-161

*Used on #15 FlexiBlocs only (3 plugs supplied on #15 with bottom P port option)

Manifold Description	1/8 NPTF	1/4 NPTF	G 1/8	G 1/4	1/4 Push-In
FlexiBlok #11: side cylinder ports	239-694	239-695	239-696	239-697	239-693
FlexiBlok #15: side & bottom cylinder ports	239-698	239-699	239-700	239-701	N/A
FlexiBlok #15 + bottom P port	239-702	239-703	239-704	239-705	N/A



Mark Plus 6 valve service kits and parts — 2 position

Kit No. MK6-K1* (for models 061BA4, 062BA4)

MARK +6

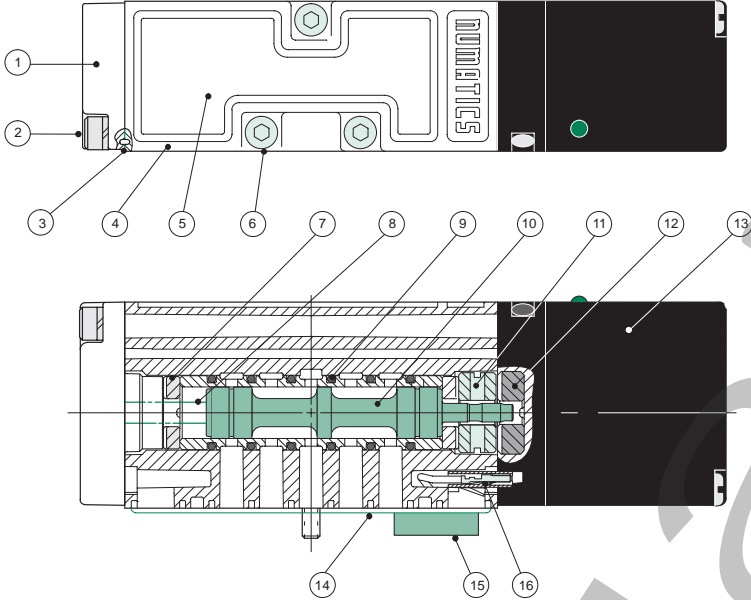

DET. NO.	NO. REQ'D.	PART NAME	PART NO.
1	1	Spring Cover	104-537
2	2	Screw Assembly	127-564
* 3	2	Gasket (valve to cover)	113-465
4	1	Valve Body (not sold separately)	
5	1	Nameplate	122-986
6	3	Screw Assembly	127-694
* 7	2	Bumper	114-181
* 8	1	Spring	115-338
* 9	6	Seals	126-347
10	1	Spool & Sleeve Assembly	209-508
* 11	1	Detent Body	110-135
* 12	1	Spacer	116-447
13	1	Solenoid Capsule Assembly	See p.12
* 14	1	Gasket (valve to mounting)	113-464
15	1	3-Wire Plug Assembly	230-715
16	1	Electrical Receptacle	150-579

* Indicates parts included in service kit.

Kit No. MK6-K2* (for models 061BB4, 062BB4)

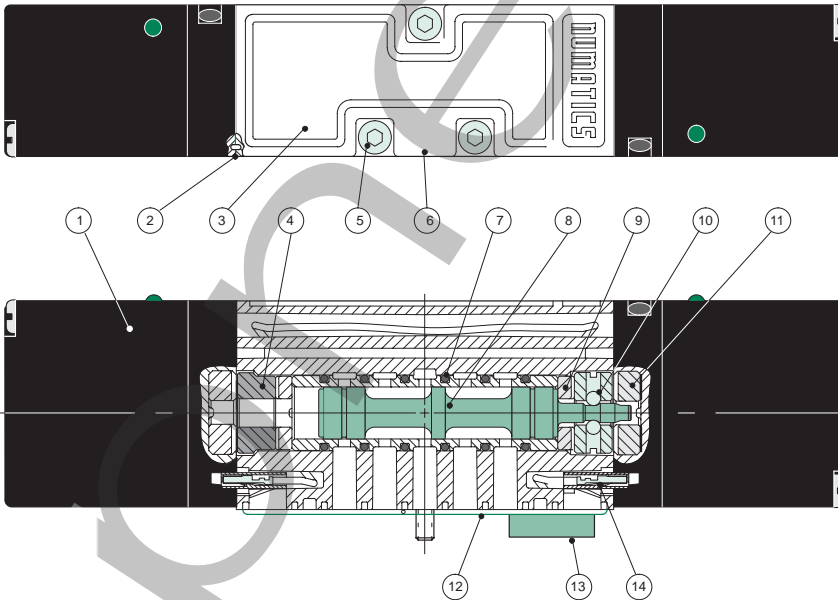

DET. NO.	NO. REQ'D.	PART NAME	PART NO.
1	2	Solenoid Capsule Assembly	See p.12
* 2	2	Gasket (valve to solenoid)	113-465
3	1	Nameplate	122-986
* 4	1	Spacer	116-440
5	3	Screw Assembly	127-694
6	1	Valve Body (not sold separately)	
* 7	6	Seals	126-347
8	1	Spool & Sleeve Assembly	209-508
* 9	2	Bumper	114-181
* 10	1	Detent Assembly	210-138
* 11	2	Spacer	116-447
* 12	1	Gasket (valve to mounting)	113-464
13	1	5-Wire Plug Assembly	230-716
14	2	Electrical Receptacle	140-579

* Indicates parts included in service kit.

Spool & sleeve assemblies are precision matched sets & include (6) 126-347 seals; spools are not interchangeable.

Mark Plus 6 valve service kits and parts — 3 position

Kit No. MK6-K3* (for models 061BBB5, 062BB5)

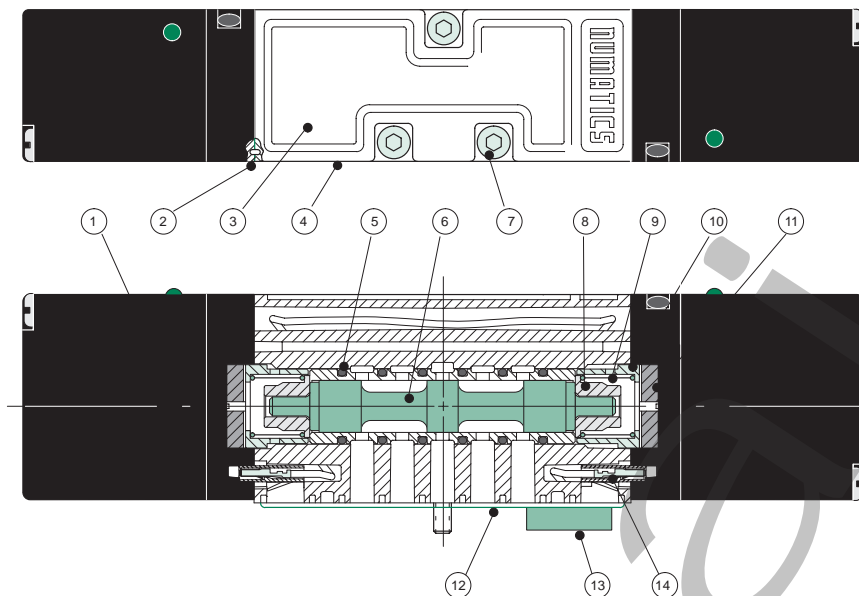

DET. NO.	NO. REQ'D.	PART NAME	PART NO.
1	2	Solenoid Capsule Assembly	See p.12
*2	2	Gasket	113-465
*3	1	Nameplate	122-986
4	1	Valve Body (not sold separately)	
5	6	Seal	126-347
*6	1	Spool & Sleeve Assembly	209-509
7	3	Screw Assembly	127-694
8	2	Spring Retainer	116-438
*9	2	Spring	115-340
*10	2	Spacer	116-439
*11	2	Bumper	114-180
*12	1	Gasket	113-464
13	1	5-Wire Plug Assembly	230-716
14	2	Electrical Receptacle	140-579

* Indicates parts included in service kit.

MARK +6

Kit No. MK6-K3* (for models 061BB6, 062BB6)

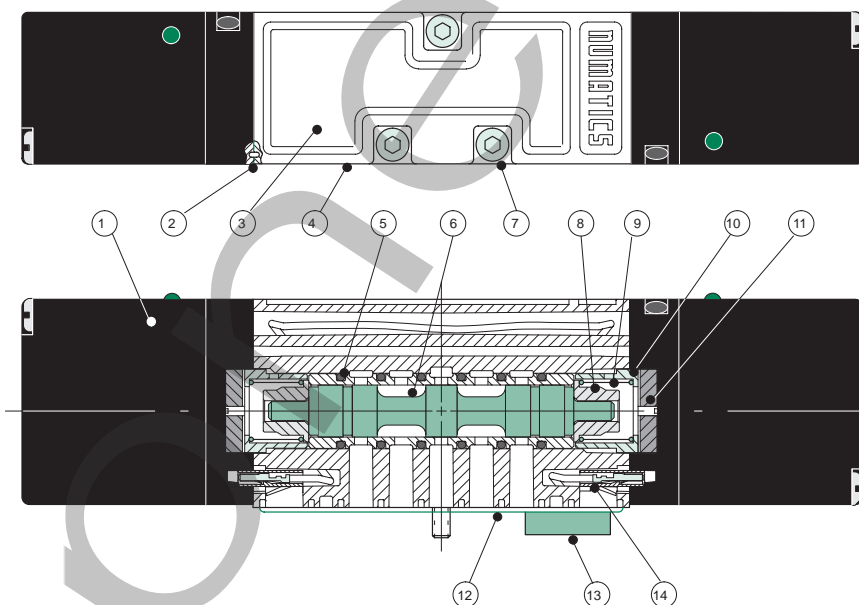

DET. NO.	NO. REQ'D.	PART NAME	PART NO.
1	2	Solenoid Capsule Assembly	See p.12
*2	2	Gasket	113-465
*3	1	Nameplate	122-986
4	1	Valve Body (not sold separately)	
5	6	Seal	126-347
*6	1	Spool & Sleeve Assembly	209-510
7	3	Screw Assembly	127-694
8	2	Spring Retainer	116-438
*9	2	Spring	115-340
*10	2	Spacer	116-439
*11	2	Bumper	114-180
*12	1	Gasket	113-464
13	1	5-Wire Plug Assembly	230-716
14	2	Electrical Receptacle	140-579

* Indicates parts included in service kit.

Spool & sleeve assemblies are precision matched sets & include (6) 126-347 seals; spools are not interchangeable.