

ORDER
ONLINE

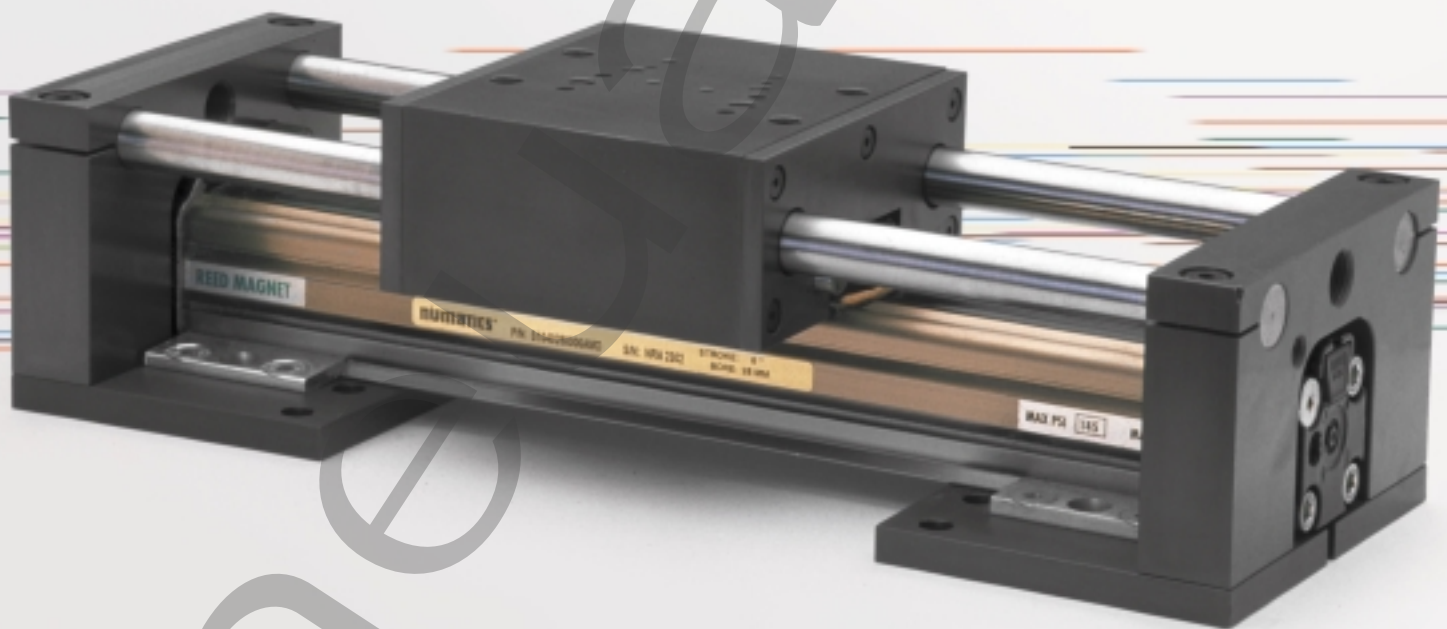

Gantries



RG Series

Rodless Gantry

We're everywhere you need us to be!



RG Series Rodless Gantry Slide 3-13

- Features and Benefits 3
- How To Order 4
- Dimensions 5
- Technical Specifications 6
- Linear and Angular Deflection 7
- Cushion Capacity 8
- Air Circuit Recommendations and Caution Statements 9-10
- Mid-Stroke Cylinder Support 11
- NuMate Compatibility 12
- Cylinder Port Locations and Shock Absorbers Dimensions 13

Pneumatic



RG Series Rodless Gantry Slide



The design centers around two separate systems. The gantry, a guided and supported bearing system, to support the load and the rodless cylinder to drive the gantry carriage.

Product Benefits

A. Carriage:

- High Load Capacity.....rigid bearing system,
guided and supported
- Hardcoat Anodized
- Aluminumlight weight, high durability
- NuMate™ Direct**
- Mounting SystemNumatics Motion Control SH-Series,
..B-Series and LC-Series
linear slides mount directly
to carriage without the use of
adapters or transition plates,
ideal for multi axis motion,
increased flexibility, reduces cost

B. Rodless Cylinder: Numatics NR-Series Rodless Cylinder

- Single Extruded Bodyincreased rigidity
- Kevlar Reinforced
- Sealing Strips.....tight seal, eliminates seal strip stretch
- Extend/Retract
- Cushionsadjustable, standard
- Magnetic Pistonstandard, for hall effect
and reed switch options

C. Alignment Coupler:

- Multi Axis
- Float System.....isolates rodless cylinder carriage
from destructive side and
compressive loads
- All loads, dynamic and static are supported by gantry guided
bearing system

D. Toolbars, Mounting Plates:

- Clearance Drilledeasy access mounting
- Dowel Location Slotsaccurate mounting and positioning
- Tapped Holes For
- Shock Absorbers.....standard, accept industry available shocks

E. Guide Shafts: (two choices)

- Hardened Steelhardness Rc 60-65, long life
- Stainless Steelhardness Rc 50-55 corrosion resistant
- Precision Ground
- & Polished15u RMS finish, smooth,
high bearing life
- Large Diametersincreased load capacity,
decreased deflection
- Pilot Mounted
- To Tool Barsmaximum rigidity, increased strength

F. Bearings (two choices)

- Four Linear
- Ball Bearings.....greatest load capacity, self lubricating, built-in wiper seals, self-
aligning
- Four Frelon® Compounded
- Teflon®self lubricating, self-aligning,
long service life

G. Stroke Adjustment Screws:

- Extend And
- Retract Positionsstandard, fine adjustment for
carriage travel

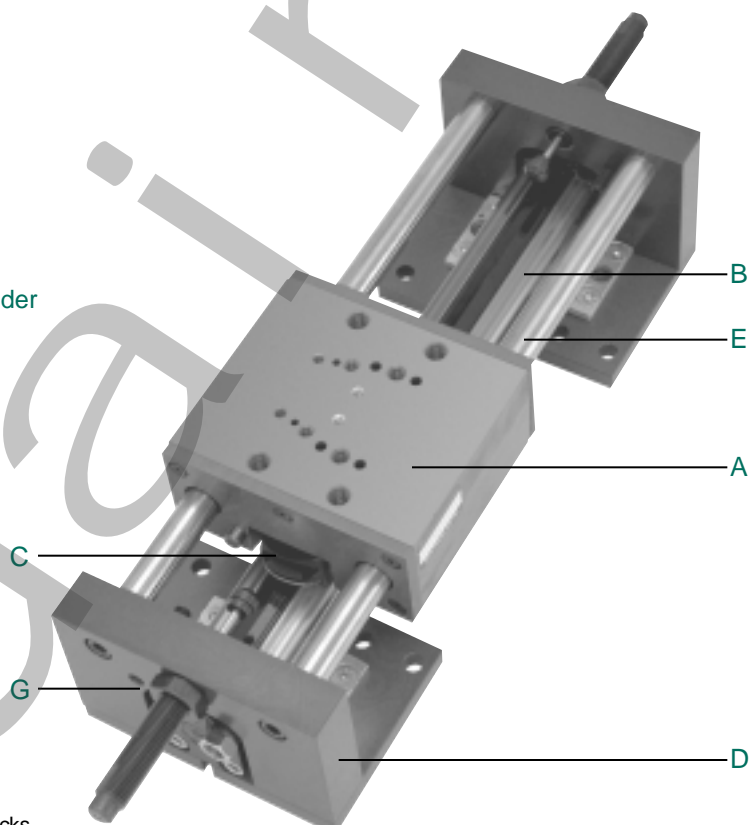



RG Series
Rodless Gantry Slide

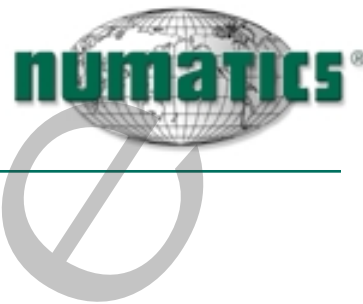

How to Order

RG 32D 035 A 1 6 D R 4

Bore and Guide

Shaft Diameter

- 25B = 25 mm Bore - 5/8" Dia. Shafts
- 32C = 32 mm Bore - 3/4" Dia. Shafts
- 32D = 32 mm Bore - 1" Dia. Shafts
- 40D = 40 mm Bore - 1" Dia. Shafts

Stroke

001 to 120 Inches

Fractional Stroke

without Mid-Support Plate

- A = 0 Inch
- C = 1/4 Inch
- E = 1/2 Inch
- G = 3/4 Inch

with Mid-Support Plate

- Z = 0 Inch
- X = 1/4 Inch
- V = 1/2 Inch
- T = 3/4 Inch

Reference page 11.

Bearing and Guide Shaft

- 1 = Linear Ball - Hardened Steel Shafts
- 2 = Linear Ball - Stainless Steel Shafts*
- 3 = Teflon - Hardened Steel Shafts
- 4 = Teflon - Stainless Steel Shafts*

*Stainless steel shafts, includes all stainless hardware.

Shock Absorbers

- 1 = Right
- 2 = Left
- 3 = Right and Left
- 4 = No Shocks

Reference page 13.

Port Location

- R = Right Double
- L = Left Double
- S = Single Each End

Reference page 13.

Sensing Position

- A = Single Position Right
- B = Single Position Left
- C = Both Right and Left
- D = No Sensing

Sensing Type

Standard Cord Set

- 1 = Hall Effect - PNP (sourcing)
- 2 = Hall Effect - NPN (sinking)
- 3 = Reed Switch
- 6 = No Sensing
- 7* = 8 mm Prox Ready

Quick Disconnect Cord Set

- Z = Hall Effect - PNP (sourcing)
- Y = Hall Effect - NPN (sinking)
- X = Reed Switch

See Sensor section.

*Does not include switch.

Example order:

Part Number: RG32D035A16DR4

Part Description: 32 mm bore, 1" dia. guide shafts, 35" stroke, no mid-support plate, 0 fractional inches, linear ball bearings, hardened steel shafts, no sensing, ports on right side, no shocks.

*When entering an order, DO NOT use spaces or dashes.

SWITCH	STANDARD	QUICK DISCONNECT
DESCRIPTION	PART NO.	PART NO.
Reed Switch	RSS02	RSQ02
Hall Effect-PNP (Sourcing)	HPNPS31	HPNPQ31
Hall Effect-NPN (Sinking)	HNPNS32	HNPNQ32
90° 5 meter cable	-	PXC90
Straight 5 meter cable	-	PXCST

SERIES	SWITCH BRACKET	SHOCK	MID-SUPPORT PLATE
RG25B	RB25	SK106	MSP25B
RG32C	RB32	SK150	MSP32C
RG32D	RB32	SK200	MSP32D
RG40D	RB40	SK250	MSP40D



RG Series
Rodless Gantry Slide



RG Series Dimensions

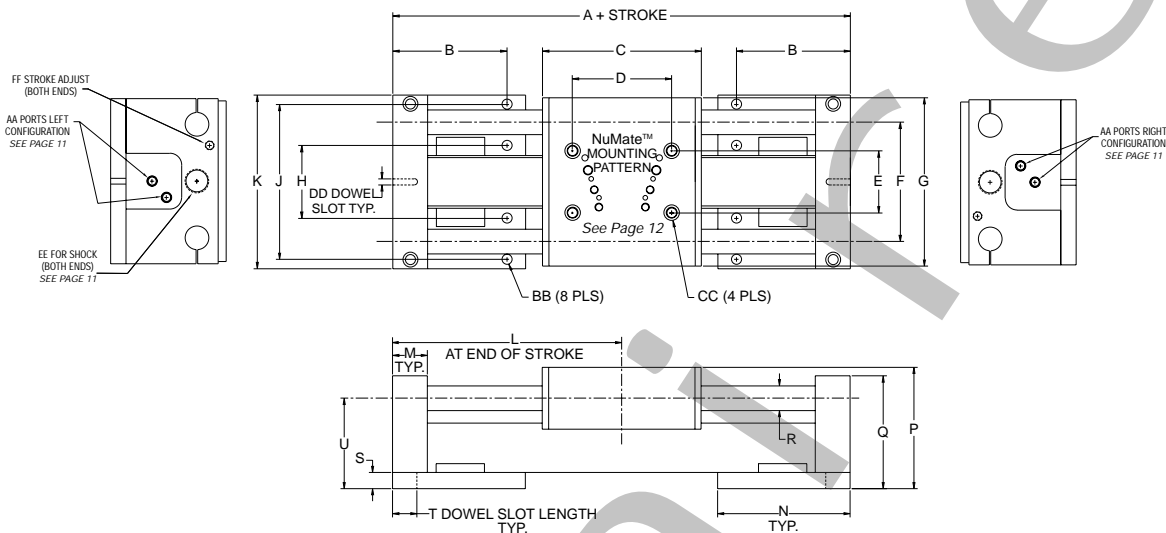

	RG25B		RG32C		RG32D		RG40D	
	Inches	(mm)	Inches	(mm)	Inches	(mm)	Inches	(mm)
A	7.875	(200.0)	9.843	(250.0)	9.843	(250.0)	11.843	(300.8)
B	3.250	(82.6)	4.000	(101.6)	4.600	(116.8)	4.600	(116.8)
C	4.401	(111.8)	5.125	(130.2)	6.400	(162.6)	6.400	(162.6)
D	3.250	(82.6)	3.500	(88.9)	4.000	(101.6)	4.000	(101.6)
E	1.500	(38.1)	2.000	(50.8)	2.500	(63.5)	2.500	(63.5)
F	3.250	(82.6)	3.780	(96.0)	4.812	(122.2)	4.812	(122.2)
G	4.625	(117.5)	5.250	(133.4)	6.800	(172.7)	6.800	(172.7)
H	2.250	(57.2)	2.875	(73.0)	2.930	(74.4)	2.930	(74.4)
J	4.250	(108.0)	5.000	(127.0)	6.250	(158.8)	6.250	(158.8)
K	4.936	(125.4)	5.750	(146.1)	7.000	(177.8)	7.000	(177.8)
L	3.937	(100.0)	4.921	(125.0)	4.921	(125.0)	5.921	(150.4)
M	0.950	(24.1)	0.965	(24.5)	1.400	(35.6)	1.400	(35.6)
N	3.750	(95.3)	5.000	(127.0)	5.350	(135.9)	5.350	(135.9)
P	3.875	(98.4)	4.750	(120.7)	4.900	(124.5)	5.750	(146.0)
Q	3.375	(85.7)	4.375	(111.1)	4.550	(115.6)	5.400	(137.1)
R	0.625	(15.9)	0.750	(19.1)	1.000	(25.4)	1.000	(25.4)
S	0.375	(9.5)	0.625	(15.9)	0.650	(16.5)	0.650	(16.5)
T	0.590	(15.0)	0.950	(24.1)	0.980	(24.9)	0.980	(24.9)
U	2.875	(73.0)	3.750	(95.3)	3.650	(92.7)	4.500	(114.3)
AA	1/8 NPT		1/4 NPT		1/4 NPT		1/4 NPT	
BB	Clearance for 5/16 SHCS		Clearance for 3/8 SHCS		Clearance for 3/8 SHCS		Clearance for 3/8 SHCS	
CC	Tapped 3/8-24 x 0.600 DP;		Tapped 3/8-24 x 0.625 DP;		Tapped 7/16-20 X 0.75 DP;		Tapped 7/16-20 X 0.75 DP;	
DD	0.1870/0.1880 (4.75/4.78)		0.2490/0.2500 (6.32/6.35)		0.2490/0.2500 (6.32/6.35)		0.2490/0.2500 (6.32/6.35)	
EE	9/16-18		3/4-16		1-12		1-12	
FF	5/16-24		3/8-24		3/8-24		3/8-24	

Unit Weight Table

BORE SIZE	BASE UNIT WEIGHT (LBS.)		ADDER PER INCH OF STROKE (LBS.)
	LINEAR BALL	TEFLON	
RG25B	8.70	8.62	0.21
RG32C	14.32	14.24	0.31
RG32D	23.67	23.49	0.40
RG40D	26.30	26.12	0.53

Multiply the adder by the stroke and add to the base weight.
Sample weight calculation for Model # RG32C028C16DR4:

Unit Output Force Table

BORE SIZE	FORCE OUTPUT (LBS.)
RG25B	Pressure (psi) x 0.76
RG32C	Pressure (psi) x 1.25
RG32D	Pressure (psi) x 1.25
RG40D	Pressure (psi) x 1.95

Multiply the air pressure being used (psi) by the appropriate number above to obtain force output in lbs. Sample calculation for RG25B021A16DR4 operated at 75 psi:
Force Output = 75 psi x 0.76 = 57.00 lbs.



RG Series
Rodless Gantry Slide



Technical Operating Performance Data

Maximum Operating Pressure: 145 psi (10 Bar)
 Minimum Operating Pressure: 30 psi (2.5 Bar)
 Maximum Stroke: 10 feet (3.0 meters)*
 Maximum Operating Speed:
 Linear Ball Bearing 6 feet/sec (1.8 meters/sec)
 Teflon Bearing 2.3 feet/sec (.7 meters/sec)
 Operating Temperature: -4°F to 175°F (-20°C to 80°C)
 No Lube Service, Filtered Air Recommended
 *contact factory for strokes exceeding 10 feet (3.0 meters)

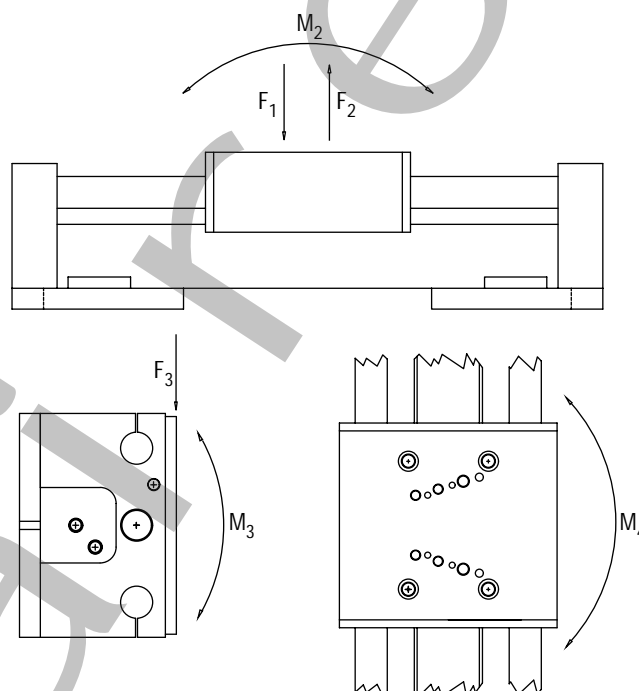

Linear Ball Bearing Dynamic Loads

SLIDE SERIES	F ₁ /F ₂ /F ₃		M ₂		M ₃		M ₄	
RG25B	160 lb	(72.6 kg.)	178 inlb	(20.1 Nm)	455 inlb	(51.4 Nm)	455 inlb	(51.4 Nm)
RG32C	275 lb	(124.7 kg.)	262 inlb	(29.6 Nm)	790 inlb	(89.3 Nm)	790 inlb	(89.3 Nm)
RG32D	520 lb	(235.9 kg.)	435 inlb	(49.1 Nm)	1657 inlb	(187.2 Nm)	1657 inlb	(187.2 Nm)
RG40D	520 lb	(235.9 kg.)	435 inlb	(49.1 Nm)	1657 inlb	(187.2 Nm)	1657 inlb	(187.2 Nm)

Note: For Static Loads Multiply Dynamic Loads By 1.3

Teflon Dynamic Loads

SLIDE SERIES	F ₁ /F ₂ /F ₃		M ₂		M ₃		M ₄	
RG25B	112 lb	(50.8 kg)	124 inlb	(14.0 Nm)	318 inlb	(35.9 Nm)	318 inlb	(35.9 Nm)
RG32C	193 lb	(87.5 kg)	183 inlb	(20.7 Nm)	553 inlb	(62.5 Nm)	553 inlb	(62.5 Nm)
RG32D	364 lb	(165.1 kg)	304 inlb	(34.3 Nm)	1150 inlb	(130.9 Nm)	1150 inlb	(130.9 Nm)
RG40D	364 lb	(165.1 kg)	304 inlb	(34.3 Nm)	1150 inlb	(130.9 Nm)	1150 inlb	(130.9 Nm)

NOTE: For Static Loads Multiply Dynamic Loads By 1.3

Maximum Allowable Load (lbs) vs. Stroke (in)

MODEL	Stk=>	5	10	15	20	25	30	35	40	45	50	55	60	65	70	75	80	85	90	95	100	105	110
RG25B	F1/F2	Max	Max	Max	Max	Max	Max	138*	102	80	66	56	49	44	41	38	35	33	31	30	29	28	27
	F3	Max	Max	Max	Max	Max	Max	Max	Max	143*	104	78	60	46	36	29	23	18	14	10	8	5	3
RG32C	F1/F2	Max	Max	Max	Max	Max	Max	Max	Max	236*	185	150	126	109	96	86	78	72	67	63	59	57	54
	F3	Max	Max	Max	Max	Max	Max	Max	Max	Max	213*	164	128	102	82	67	54	45	37	30	24	19	
RG32D	F1/F2	Max	Max	Max	Max	Max	Max	Max	Max	493*	379*	299	242	200	168	144	124	109	96	86	77	70	
	F3	Max	Max	Max	Max	Max	Max	Max	Max	Max	Max	505*	393*	310	248	200	162	132	108	88	71	57	
RG40D	F1/F2	Max	Max	Max	Max	Max	Max	Max	Max	493*	379*	299	242	200	168	144	124	109	96	86	77	70	
	F3	Max	Max	Max	Max	Max	Max	Max	Max	Max	Max	505*	393*	310	248	200	162	132	108	88	71	57	

For Kilograms Multiply Pounds x .45359. For Example: 80 (lbs) x .45359 = 36.29 Kg

* Use Max Loads for the Teflon Bearing Option from the Table Above.



Linear Deflection

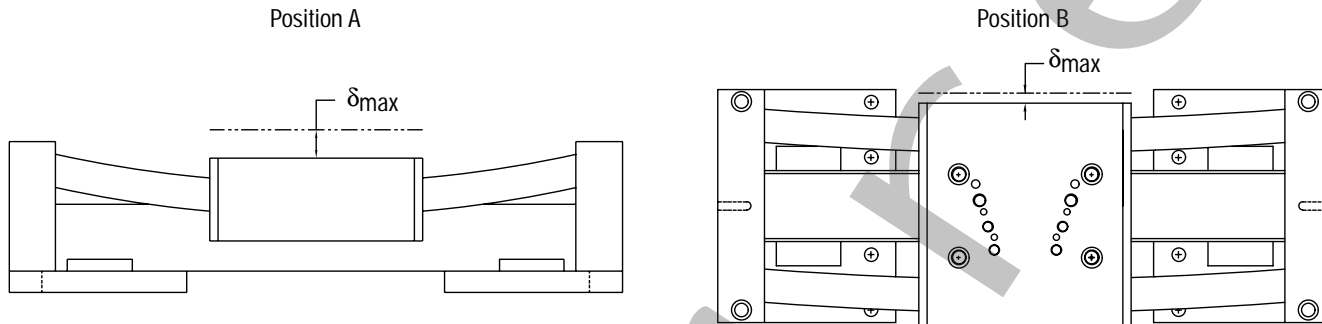

POSITION A

RG25B	$\delta_{max} = \left[(LOAD) \left(\frac{STROKE}{2} - 1.200 \right)^3 \left(2 + \frac{19.5}{STROKE-2.40} \right) 4.6491 \times 10^{-8} \right] + [STROKE + 5.975]^4 1.0311 \times 10^{-9}$
RG32C	$\delta_{max} = \left[(LOAD) \left(\frac{STROKE}{2} - 1.500 \right)^3 \left(2 + \frac{18.0}{STROKE-3.00} \right) 2.2515 \times 10^{-8} \right] + [STROKE + 7.913]^4 7.2282 \times 10^{-10}$
RG32D	$\delta_{max} = \left[(LOAD) \left(\frac{STROKE}{2} - 1.828 \right)^3 \left(2 + \frac{21.9}{STROKE-3.66} \right) 7.1055 \times 10^{-9} \right] + [STROKE + 7.043]^4 4.0626 \times 10^{-10}$
RG40D	$\delta_{max} = \left[(LOAD) \left(\frac{STROKE}{2} - 1.828 \right)^3 \left(2 + \frac{21.9}{STROKE-3.66} \right) 7.1055 \times 10^{-9} \right] + [STROKE + 7.043]^4 4.0626 \times 10^{-10}$

POSITION B

RG25B	$\delta_{max} = \left[(LOAD) \left(\frac{STROKE}{2} - 1.200 \right)^3 \left(2 + \frac{19.5}{STROKE-2.40} \right) 3.2544 \times 10^{-8} \right] + [STROKE + 5.975]^4 1.0311 \times 10^{-9}$
RG32C	$\delta_{max} = \left[(LOAD) \left(\frac{STROKE}{2} - 1.500 \right)^3 \left(2 + \frac{18.0}{STROKE-3.00} \right) 1.5761 \times 10^{-8} \right] + [STROKE + 7.913]^4 7.2282 \times 10^{-10}$
RG32D	$\delta_{max} = \left[(LOAD) \left(\frac{STROKE}{2} - 1.828 \right)^3 \left(2 + \frac{21.9}{STROKE-3.66} \right) 4.9739 \times 10^{-9} \right] + [STROKE + 7.043]^4 4.0626 \times 10^{-10}$
RG40D	$\delta_{max} = \left[(LOAD) \left(\frac{STROKE}{2} - 1.828 \right)^3 \left(2 + \frac{21.9}{STROKE-3.66} \right) 4.9739 \times 10^{-9} \right] + [STROKE + 7.043]^4 4.0626 \times 10^{-10}$

Load and stroke input by customer

Angular Deflection

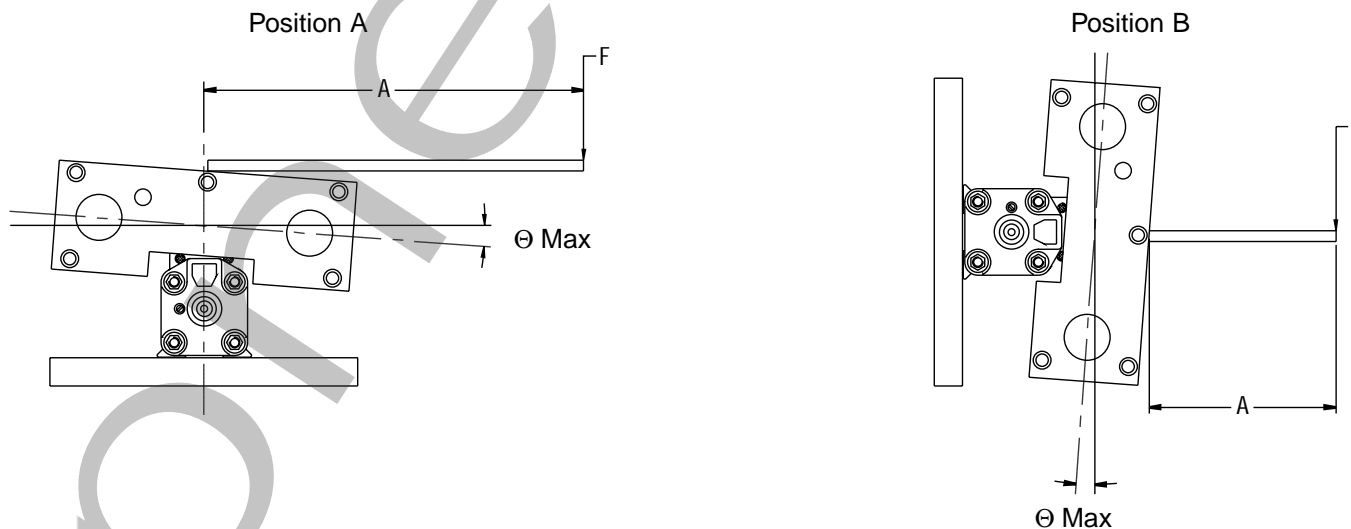

POSITION A

POSITION B

ANGULAR DEFLECTION

RG25B	M=FA	M=F(A+1.00)	RG25B	$\Theta_{max} = \tan^{-1} \left[M \left(\frac{STROKE+3.592}{2} \right)^3 \left(2 + \frac{14.29}{STROKE-3.592} \right) 3.5212 \times 10^{-8} \right]$
RG32C	M=FA	M=F(A+1.00)	RG32C	$\Theta_{max} = \tan^{-1} \left[M \left(\frac{STROKE+4.928}{2} \right)^3 \left(2 + \frac{17.91}{STROKE-4.928} \right) 1.2606 \times 10^{-8} \right]$
RG32D	M=FA	M=F(A+1.25)	RG32D	$\Theta_{max} = \tan^{-1} \left[M \left(\frac{STROKE+3.405}{2} \right)^3 \left(2 + \frac{21.81}{STROKE-3.405} \right) 2.4550 \times 10^{-9} \right]$
RG40D	M=FA	M=F(A+1.25)	RG40D	$\Theta_{max} = \tan^{-1} \left[M \left(\frac{STROKE+3.405}{2} \right)^3 \left(2 + \frac{21.81}{STROKE-3.405} \right) 2.4550 \times 10^{-9} \right]$



RG Series Rodless Gantry Slide



The cushions on the RG-Series rodless gantry slides are designed to absorb a certain amount of kinetic energy. The amount of kinetic energy developed by the moving gantry carriage is a function of the weight (W), and the velocity at which it is being moved.

The maximum allowable final velocity (V_f) can be calculated using the formula below. The final velocity is defined to be at the point where the rodless cylinder enters the cushion. This is a fixed distance from end of stroke. The weight (W), is the weight of the load attached to the gantry carriage, plus the weight of the gantry carriage itself. The various values mentioned above are listed in the table below.

Cushion Capacity (Kinetic Energy)

MODEL	MAX. KINETIC ENERGY (KE)	POSITION IN STROKE FOR V_f	CARRIAGE WEIGHT
RG25B	13 in-lb	0.98 in From End of Stroke	3 lbs
RG32C	22 in-lb	1.28 in From End of Stroke	4 lbs
RG32D	22 in-lb	1.28 in From End of Stroke	8 lbs
RG40D	35 in-lb	1.64 in From End of Stroke	8 lbs

$$V_F = \sqrt{\frac{(KE) \times 772.2}{W}}$$

Where:

KE = Kinetic Energy value from the table above

W = Weight of carriage from table above + Weight of attached load

V_f = Maximum allowable final velocity (in/sec) - See table above for position in stroke

In a system that does not have any deceleration or speed control methods, the final velocity (V_f) can be approximated at 2 times the average velocity (stroke/time). Most applications will exceed the maximum allowable kinetic energy for the cushions in these cases. For these situations, there are two options. The first option is to use shock absorbers (see page 47). Below are graphical representations of the above equation. These graphs provide a quick reference for determining when shock absorbers must be used.

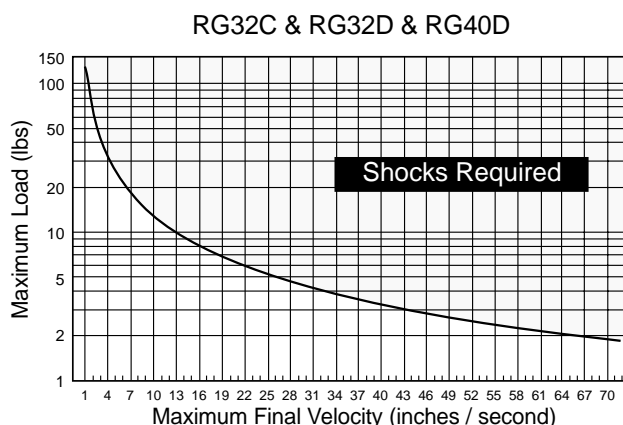
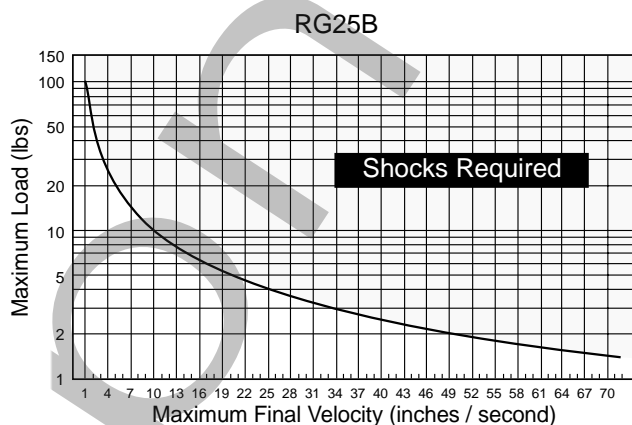

The second option is to control the velocity of the gantry slide. Basically, using air control methods to ensure that the final velocity (V_f) is equal to or less than the maximum number shown on the graphs above (or calculated from the formula above.) The next two pages detail these methods.

**CAUTION!!!**

Failure to control carriage speed may cause NON-repairable damage to the rodless cylinder piston assembly. The carriage velocity must be controlled. Shock absorbers are a standard option and should be used whenever possible. The use of shock absorbers will decelerate the load prior to the rodless cylinder contacting the end cap. See page 510 for determination of shock absorber requirements.

CAUTION!!!

Failure to provide the rodless cylinder with back pressure may cause NON-repairable damage to the rodless cylinder piston assembly. Back pressure is required to control piston speed. The absence of back pressure allows the piston assembly to travel at terminal speeds. Contacting the end cap at these speeds will cause NON-repairable damage to the piston assembly.

The charts below show recommended and not recommended speed profiles for a rodless gantry.

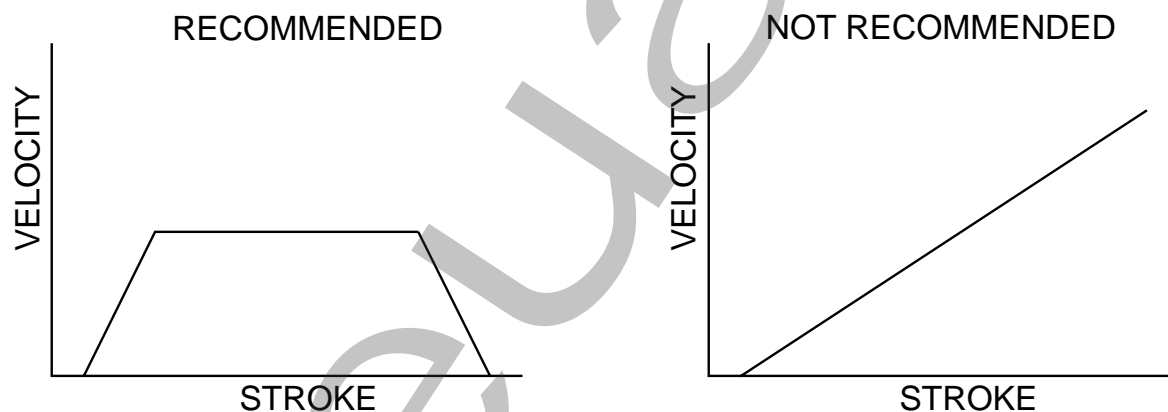

Air Circuit Recommendations for Velocity Control

Flow Controls

- Help maintain consistent speed and provide back pressure.
- Most effective when mounted in the control ports.

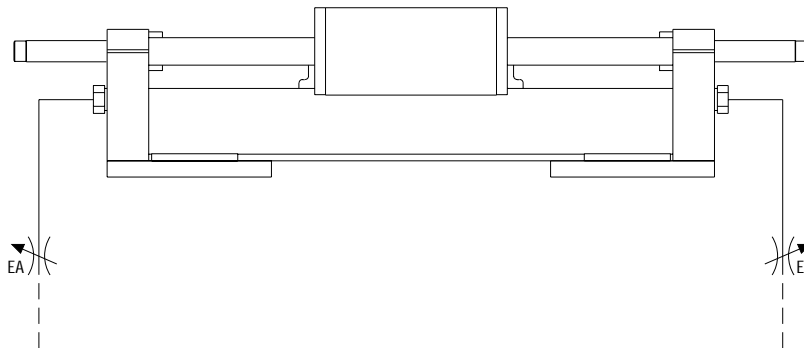



RG Series Rodless Gantry Slide



Two Pressure Select (extend at one pressure, retract at another)

- Recommended when the gantry drives a load in one direction, but has no load in the reverse direction.
- The driving load direction operates at one pressure, the no load direction operates at a reduced pressure.

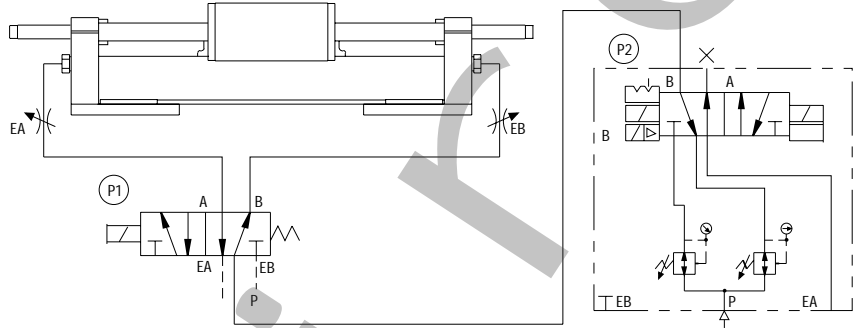

Deceleration Circuit Using Limit Valves

- Provides the best control.
- Gantry allowed to travel at maximum speed through most of stroke. Prior to reaching end of stroke, the limit valve is tripped, shifting the exhaust pressure to the opposite end, slowing the cylinder travel. External sensors can be used in place of limit valve.
- When switches are used to sense the magnet on the piston, the speed of the piston cannot exceed 2 ft/sec for proper functioning of the switch.

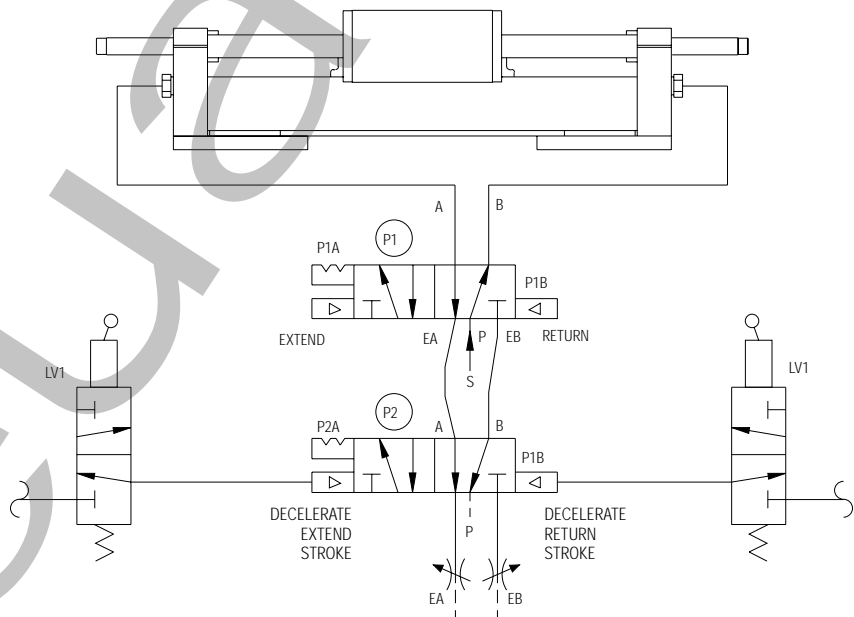

Deceleration Circuit Using Sensor Feedback

- Limit switches are energized as the carriage passes a given point, triggering a command to the electronic device, which chokes the exhausting air, reducing the speed to an acceptable value prior to striking the cushion.

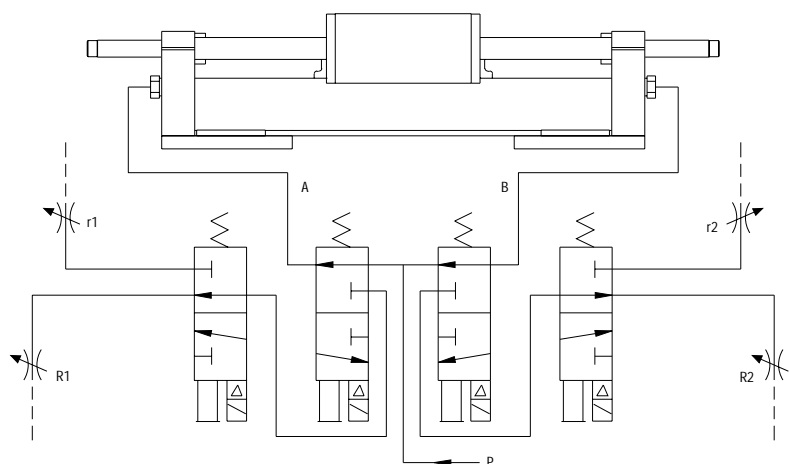



RG Series
Rodless Gantry Slide



Mid-Stroke Cylinder Support

When the stroke of the rodless gantry slide exceeds a certain amount, a support must be placed under the cylinder at mid-stroke. The table above right indicates the maximum stroke length a rodless gantry slide can be operated without a mid-support. This applies to all horizontal mounting configurations. The drawing to the right shows a mid-stroke support available from NMC. See page 4 for ordering instructions.

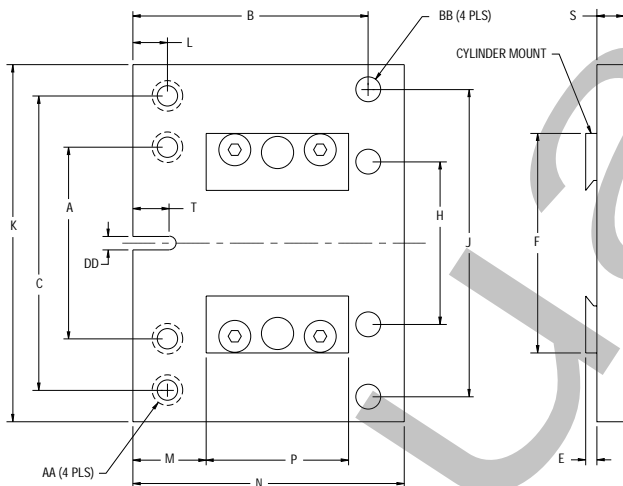
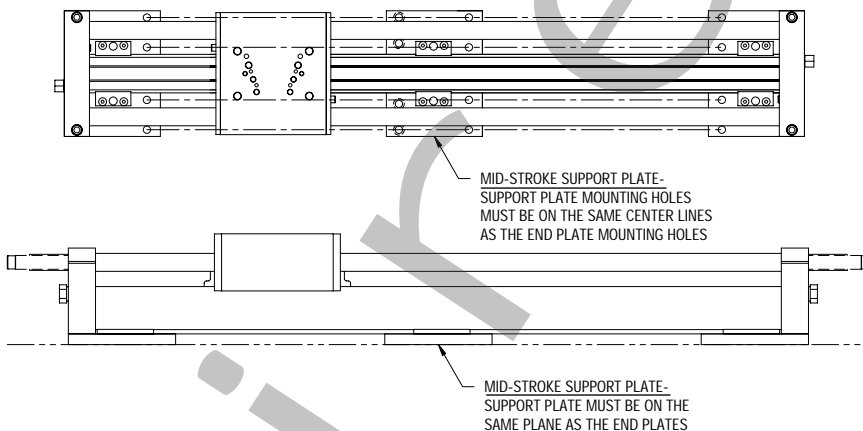

MAXIMUM STROKE PERMITTED WITHOUT MID-STROKE CYLINDER SUPPORT	
RG25B	30 inches
RG32C	40 inches
RG32D	45 inches
RG40D	45 inches

	RG25B		RG32C		RG32D		RG40D	
	Inches	(mm)	Inches	(mm)	Inches	(mm)	Inches	(mm)
A	2.650	(67.3)	3.000	(76.2)	3.370	(85.6)	3.370	(85.6)
B	3.250	(82.6)	4.000	(101.6)	4.600	(116.8)	4.600	(116.8)
C	4.070	(103.4)	4.800	(121.9)	6.250	(158.8)	6.250	(158.8)
E	0.160	(4.1)	0.160	(4.1)	0.160	(4.1)	0.160	(4.1)
F	3.037	(77.1)	3.587	(91.1)	3.587	(91.1)	4.486	(114.0)
H	2.250	(57.2)	2.875	(73.0)	2.930	(74.4)	2.930	(74.4)
J	4.250	(108.0)	5.000	(127.0)	6.250	(158.8)	6.250	(158.8)
K	4.936	(125.4)	5.750	(146.1)	7.000	(177.8)	7.000	(177.8)
L	0.475	(12.1)	0.480	(12.2)	0.700	(17.8)	0.700	(17.8)
M	0.996	(25.3)	1.274	(32.4)	1.724	(43.8)	1.724	(43.8)
N	3.750	(95.3)	5.000	(127.0)	5.350	(135.9)	5.350	(135.9)
P	2.000	(50.8)	2.000	(50.8)	2.000	(50.8)	2.000	(50.8)
S	0.375	(9.5)	0.625	(15.9)	0.650	(16.5)	0.650	(16.5)
T	0.590	(15.0)	0.950	(24.1)	0.980	(24.9)	0.980	(24.9)
AA	C'bore for 1/4 LHCS from Opposite Side.		C'bore for 3/8 LHCS from Opposite Side.		C'bore for 3/8 LHCS from Opposite Side.		C'bore for 3/8 LHCS from Opposite Side.	
BB	Clearance for 5/16 SHCS		Clearance for 3/8 SHCS		Clearance for 3/8 SHCS		Clearance for 3/8 SHCS	
DD	0.1870/0.1880 (4.75/4.78)		0.2490/0.2500 (6.32/6.35)		0.2490/0.2500 (6.32/6.35)		0.2490/0.2500 (6.32/6.35)	



RG Series
Rodless Gantry Slide

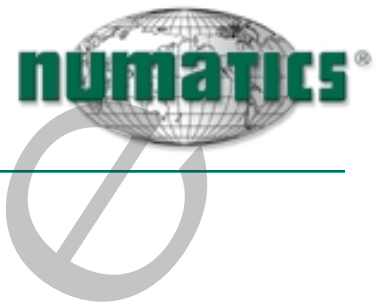

NuMate™ Compatibility

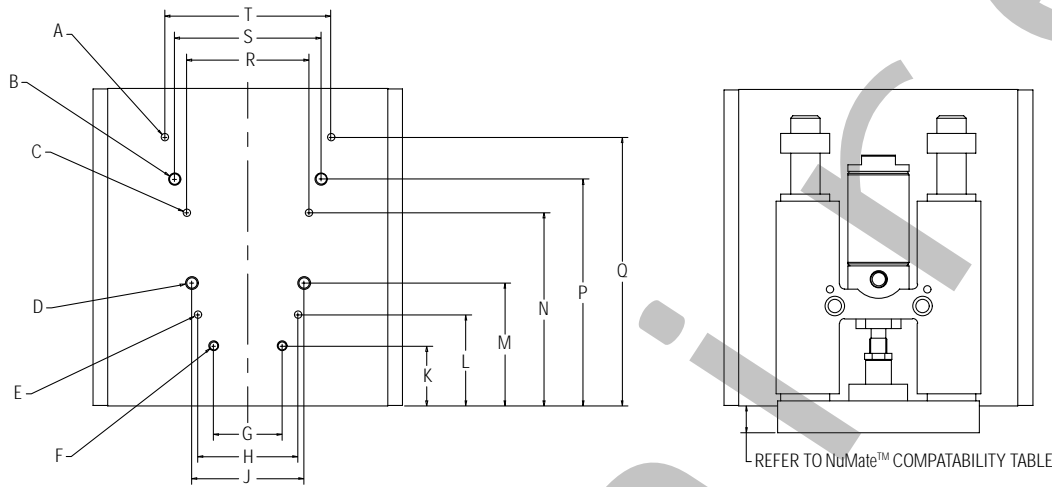

NuMate™ Pattern Dimensional Data (Patent No. 5,560,281)

	RG25B		RG32C		RG32D & RG40D	
	Inches	(mm)	Inches	(mm)	Inches	(mm)
A	0.187/0.188 x 0.37 DP		0.187/0.188 x 0.37 DP		0.250/0.251 x 0.50 DP	
B	5/16-18 x 0.50 DP		5/16-18 x 0.50 DP		3/8-16 x 0.60 DP	
C	0.187/0.188 x 0.37 DP		0.187/0.188 x 0.37 DP		0.187/0.188 x 0.37 DP	
D	1/4-20 x 0.37 DP		5/16-18 x 0.50 DP		5/16-18 x 0.50 DP	
E	0.125/0.126 x 0.25 DP		0.187/0.188 x 0.37 DP		0.187/0.188 x 0.37 DP	
F	#10-32 x 0.33 DP		1/4-20 x 0.37 DP		5/16-18 x 0.50 DP	
G	1.25	(31.8)	1.50	(38.1)	1.87	(47.5)
H	1.38	(35.1)	1.81	(46.0)	1.87	(47.5)
J	1.50	(38.1)	1.87	(47.5)	2.25	(57.2)
K	1.38	(35.1)	1.50	(38.1)	2.38	(60.5)
L	1.69	(42.9)	1.87	(47.5)	2.76	(70.1)
M	1.94	(49.3)	2.25	(57.2)	3.08	(78.2)
N	2.31	(58.7)	2.63	(66.8)	3.52	(89.4)
P	2.69	(68.3)	2.95	(74.9)	3.87	(98.3)
Q	3.06	(77.7)	3.38	(85.9)	4.37	(111.0)
R	1.81	(46.0)	1.87	(47.5)	2.50	(63.5)
S	1.87	(47.5)	2.25	(57.2)	2.75	(69.8)
T	1.87	(47.5)	2.50	(63.5)	3.00	(76.2)

NuMate™ Compatibility Table & Edge Reference

	RG25B		RG32C		RG32D & RG40D	
	Inches	(mm)	Inches	(mm)	Inches	(mm)
SH056	0.50	(12.7)				
SH075	0.40	(10.2)	0.84	(21.3)		
SH106	0.22	(5.6)	0.65	(16.5)	0.52	(13.2)
SH150			0.30	(7.6)	0.16	(4.1)
SH200					0.13	(3.3)
B04	0.24	(6.1)				
B06	0.40	(10.2)				
B08	0.99	(25.2)				
LC056	-0.14	(-3.6)				
LC075	-0.35	(-8.9)	0.09	(2.3)		
LC106	-0.85	(-21.6)	-0.41	(-10.4)	-0.54	(-13.7)
LC150			-0.89	(-22.6)	-1.02	(-25.9)



Cylinder Port Location

Ports Left Option

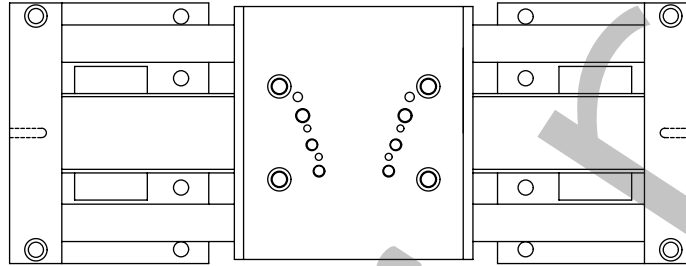
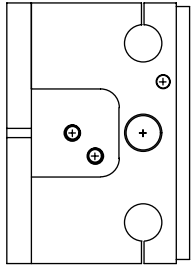

Ports Right Option

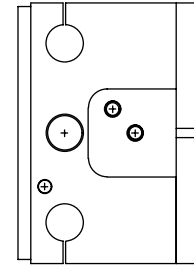

Port orientation is referenced to the NuMate™ Mounting Pattern

Shock Absorbers

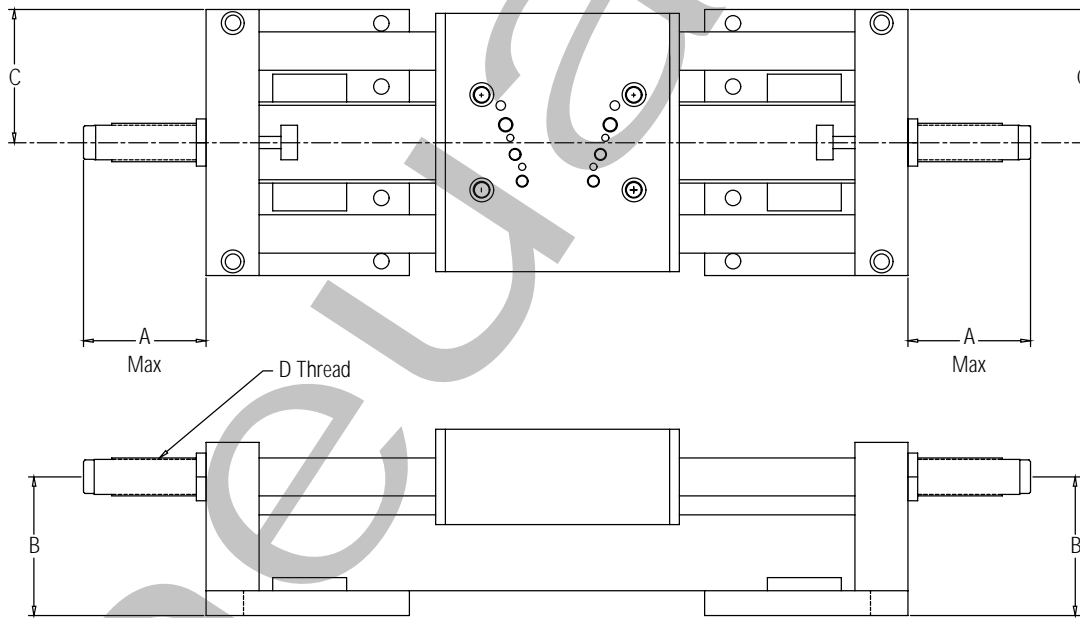

Dimensions

	RG25B		RG32C		RG32D		RG40D	
	Inches	(mm)	Inches	(mm)	Inches	(mm)	Inches	(mm)
A	3.00	(76.2)	3.00	(76.2)	3.25	(82.6)	3.25	(82.6)
B	2.88	(73.0)	3.75	(95.3)	3.65	(92.7)	4.50	(114.3)
C	2.47	(62.7)	2.88	(73.0)	3.50	(88.9)	3.50	(88.9)
D	9/16-18		3/4-16		1-12		1-12	

Shock Absorbers

	RG25B	RG32C	RG32D	RG40D
Part #	SK106	SK150	SK200	SK250