

ORDER
ONLINE

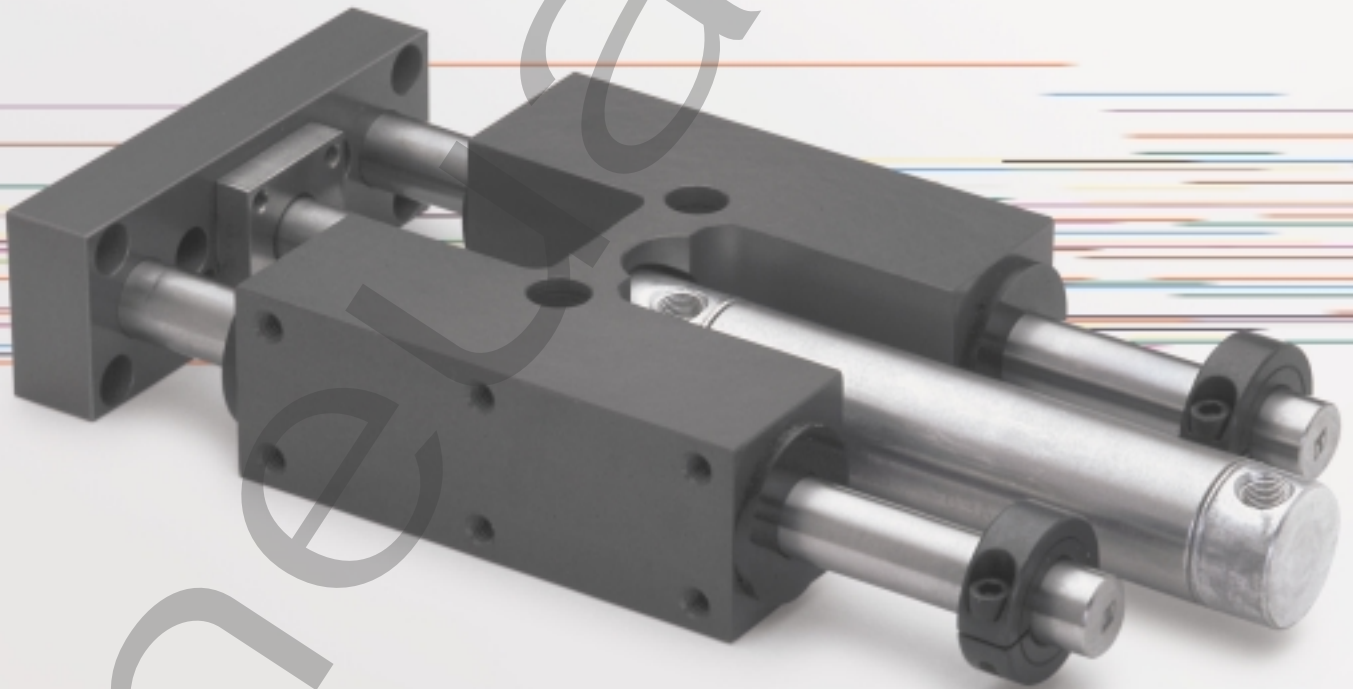

Slides



SH Series
Linear Slides

We're everywhere you need us to be!



SH Series Linear Slides

SH Series Linear Slides	3-14
Features and Benefits	3
How To Order	4
Dimensions	5-7
Specifications and Load Ratings	8-10
Mounting Options	11
NuMate Mounting System	12
Multi-Position How to Order	13
Multi-Position Dimensions	14

Pneumatic



SH Series Linear Slides



Our SH-Series Linear Slides are available with a wide range of options...

A. Body:

Hardcoat Anodized Aluminum(6061-T6511)lightweight, durable,
 high strength to weight ratio.

Standard Dowel Location Holesallows precision mounting.

Multi-Surface Mounting Holesflexible, easy access for mounting.

B. Air Cylinder:

Standard Stainless Steel Body and Rod.....corrosion resistant.

Standard w/ Magnetic Pistonsensing applications (Hall, Reed or Prox)
 added as required.

C. Alignment Coupler:

Isolates Piston Rod from side loading.....maximize life of cylinder,
 360 degrees of float.

D. Tooling Plate:

NuMate™ Universal Mounting Pattern.....standardized mounting
 system, eliminates custom transition plates.

Holes Drilled/Tapped and C'bored from the
 opposite sideeasy mounting.

Standard Dowel Locating Holesprecision mounting.

E. Guide Shafts:

Hardened Steel to Rc 60 - 65long life.

Hardened Stainless Steel to Rc 50 - 55.....long life.

Precision Ground & Polished to 15µRMS.....smooth cycling/
 low breakaway.

Pilot Mounted to Tooling Platemaximum rigidity.

Large Diameters.....increased load capacity.

F. Bearings: (Three Choices)

Four Precision Linear Ball Bearings
 Sealed with Rod Wipers.....safe guarding against dirt & contamination.
 Self-Aligningreducing wear, maximizing both.
 load capacity and long life.

Four Sintered Bronze Sleeve Bearings
 Oil Impregnatedself lubricating.

High Pv Rating.....long service life.

Four Frelon® Compounded Teflon®
 Low Frictionlongest wear life.

Maintenance Free.....self lubricating.

G. Bumpers: (Standard)

Polyurethane Materialdurable and long lasting.

Integrated into body Designreduces shock loading on extend & retract.

Preliminary Rod Wiperremoves larger contamination from Guide Shafts.

H. Adjustable Shaft Collars: (Standard)

Extend Stroke Adjustmentflexibility.

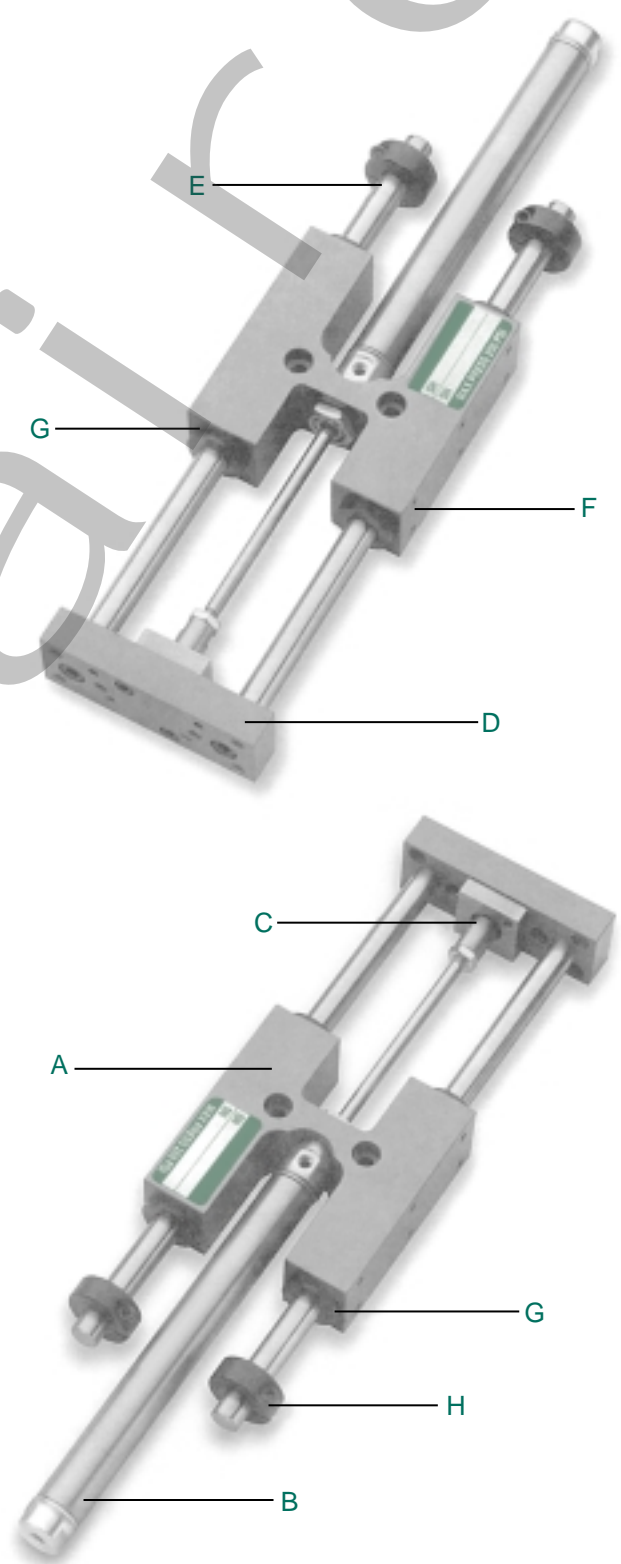

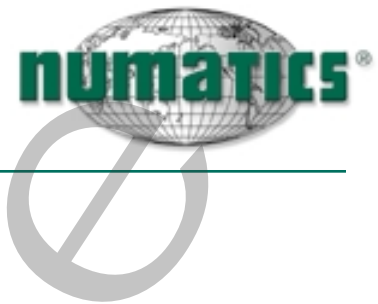

SH Series
Linear Slides

How to Order

SH 075 03 LB 1 3 C S 3

Bore Size

- 031 = 5/16"
- 056 = 9/16"
- 075 = 3/4"
- 106 = 1-1/16"
- 150 = 1-1/2"
- 200 = 2"
- 250 = 2-1/2"
- 300 = 3"

Standard Stroke (inches)

- X5 = 1/2" 09 = 9"
- 01 = 1" 10 = 10"
- X9 = 1-1/2" 11 = 11"
- 02 = 2" 12 = 12"
- 03 = 3" 13 = 13"
- 04 = 4" 14 = 14"
- 05 = 5" 15 = 15"
- 06 = 6" 16 = 16"
- 07 = 7" 17 = 17"
- 08 = 8" 18 = 18"

Refer to page 435 for slide stroke availability.

Bearing Option

- LB = Linear Ball
- TB* = Teflon®
- BB = Sintered Bronze

* Supplied Standard with Stainless Steel Guide Rods, Stop Collars and Hardware.

Cylinder Type

- 1 = Buna-N Seals***
- 2 = Viton Seals (no magnet)
- 3 = Buna-N Seals w/Cushions**
- 4 = Viton Seals with magnet***

** Cushions available on 1-1/16", 1-1/2", 2", and 2-1/2" & 3" bore.

*** Magnet not available on SH031

Shock Option

Shock Hardware Only

- 1 = Extend
- 2 = Retract
- 3 = Extend/Retract
- 4 = No Shock Hardware

Hardware & Shocks

- A = Extend
- B = Retract
- C = Extend/Retract

* See page 436 for bore size availability and dimensional changes.

Mounting Option

- S = Std. Mount
- B = Base Mount
- A = Angle Mount

Sensing Position

- A = Single Pos. Extend
- B = Single Pos. Retract
- C = Two position
- D = No Sensing

Sensing Type

Standard Cord Set

- 1 = Hall Effect PNP (Sourcing)
- 2 = Hall Effect NPN (Sinking)
- 3 = Reed Switch
- 4 = Prox Switch - PNP (Sourcing)
- 5 = Prox Switch - NPN (Sinking)
- 6 = No Sensing
- 7 = 8mm Threaded Barrel Prox Bracket*

Quick Disconnect Cord Set

- Z = Hall Effect PNP (Sourcing)
- Y = Hall Effect NPN (Sinking)
- X = Reed Switch
- W = Prox Switch - PNP (Sourcing) Straight
- V = Prox Switch - NPN (Sinking) Straight
- U = Prox Switch - PNP (Sourcing) 90°
- T = Prox Switch - NPN (Sinking) 90°

* Bracket only - does not include switch

** Sensing not available on the SH031

See Sensor section.

Ordering Example

Part Number: SH07503LB13CS3*

Part Description: 3/4 Bore by 3 inch stroke with Linear Ball Bearing, Standard Seals, Two Position Reed Switches, Standard Mount, Shock Hardware on Extend and Retract, Shocks not included.

*When entering an order, DO NOT use spaces or dashes. Follow example above.

When Ordering Additional Sensors, Mounting Kits, or Shocks:

SWITCH DESCRIPTION	STANDARD PART NO.	QUICK DISCONNECT PART NO.
Hall Effect - PNP (Sourcing)	HPNPS31*	HPNPQ31*
Hall Effect - NPN (Sinking)	HNPNS32*	HNPNQ32*
Reed Switch	RSS02*	RSQ02*
Prox Switch - PNP (Sourcing)	SWPP - 0001	SWPP - QS01
Prox Switch - NPN (Sinking)	SWPN - 0001	SWPN - QS01
Prox Switch - PNP 90°	-	SWPP - QL01
Prox Switch - NPN 90°	-	SWPN - QL01
90° 5 meter cable	-	PXC 90
Straight 5 meter cable	-	PXC ST

*Bands and tracks required for mounting.

SERIES SLIDE	BASE MOUNT	ANGLE MOUNT	SHOCK ABSORBER
SH031	MB031	AB031	-
SH056	MB056	AB056	-
SH075	MB075	AB075	SK106
SH106	MB106	AB106	SK106
SH150	MB150	AB150	SK150
SH200	MB200	AB200	SK200
SH250	-	AB200	SK250
SH300	-	-	SK300



SH Series
Linear Slides



SH031, SH056, SH075, SH106 Slides

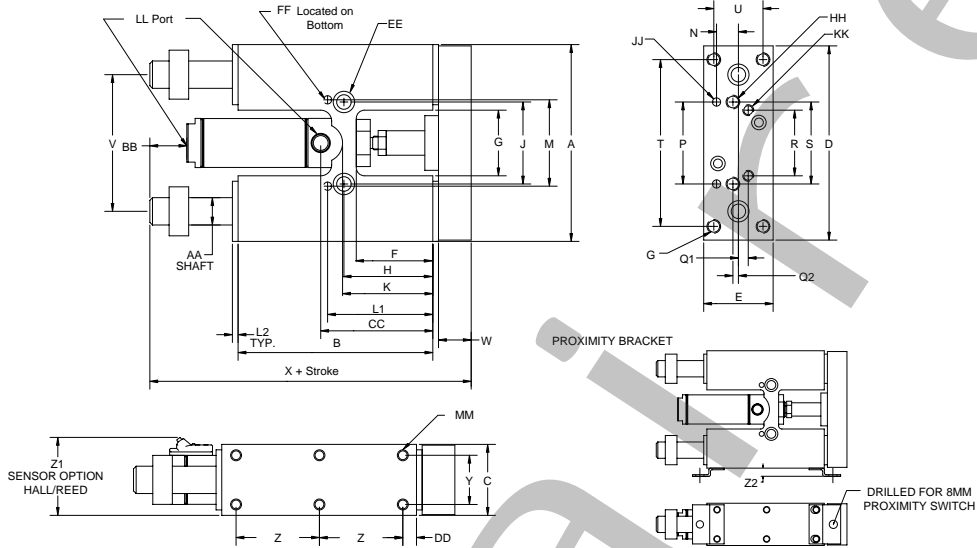

	SH031	SH056	SH075	SH106
A	2.00	2.87	4.12	4.50
B	2.00	3.00	3.97	4.45
C	0.62	1.00	1.25	1.62
D	1.95	2.81	4.06	4.44
E	0.58	0.95	1.19	1.58
F	0.75	1.00	1.31	1.75
G	0.75	1.00	1.25	1.50
H	0.90	1.25	1.59	2.03
J	1.00	1.25	1.50	1.87
K	1.06	1.50	1.66	2.31
L1	1.12	1.56	1.96	2.40
L2	0.06	0.12	0.12	0.12
M	0.999/1.001	1.373/1.375	1.811/1.813	1.873/1.875
N	0.21	0.31	0.37	0.50
P	0.999/1.001	1.373/1.375	1.811/1.813	1.873/1.875
Q1	-	0.18	0.31	0.22
Q2	Center Line	Center Line	Center Line	0.12
R	-	1.00	1.25	1.50
S	1.00	1.25	1.50	1.87
T	-	2.37	3.37	3.81
U	-	0.62	0.81	1.12
V	1.56	2.00	2.75	3.12
W	0.31	0.50	0.62	0.75
X	3.06	4.44	5.68	6.31
Y	0.43	0.62	0.81	1.12
Z	0.50	1.18	1.68	1.90
Z1	N/A	1.32	1.53	1.88
Z2	N/A	.312	.312	.312

	SH031	SH056	SH075	SH106
AA	0.250 Nom.	0.375 Nom.	0.500 Nom.	0.625 Nom.
BB	0.31	0.50	0.62	0.81
CC	1.06	1.68	2.03	2.50
DD	0.50	0.31	0.31	0.31
EE	C'Bored for #6 SHCS, Tapped # 10-32 x .28 DP From Opposite side	C'Bored for #10 SHCS, Tapped 1/4-28 x .50 DP From Opposite side	C'Bored for 1/4 SHCS, Tapped 5/16-24 x .62 DP From Opposite side	C'Bored for 5/16 SHCS, Tapped 3/8-24 x .75 DP From Opposite side
FF	0.0937/0.0947 x 0.18DP	0.125/0.126 x 0.25DP	0.1875/0.1885 x .37DP	0.1875/0.1885 x .37DP
GG		#10-32 thru, C'Bored for #6 SHCS From Opposite Side	1/4-20 thru, C'Bored for #10 SHCS From Opposite Side	5/16-18 thru, C'Bored for 1/4 SHCS From Opposite Side
HH	#6-32 thru	#10-32 thru, C'Bored For #6 SHCS From Opposite Side	1/4-20 thru, C'Bored For #10 SHCS From Opposite Side	5/16-18 thru, C'Bored For 1/4 SHCS From Opposite Side
JJ	0.0937/0.0947 x 0.18DP	0.125/0.126 x 0.25DP	0.1875/0.1885 x .37DP	0.1875/0.1885 x .37DP
KK	-	#6-32 x .25DP	#10-32 x .37DP	1/4-20 x .50DP
LL	#10-32	#10-32	1/8 NPTF	1/8 NPTF



SH Series
Linear Slides

SH150, SH200, SH250 Slides

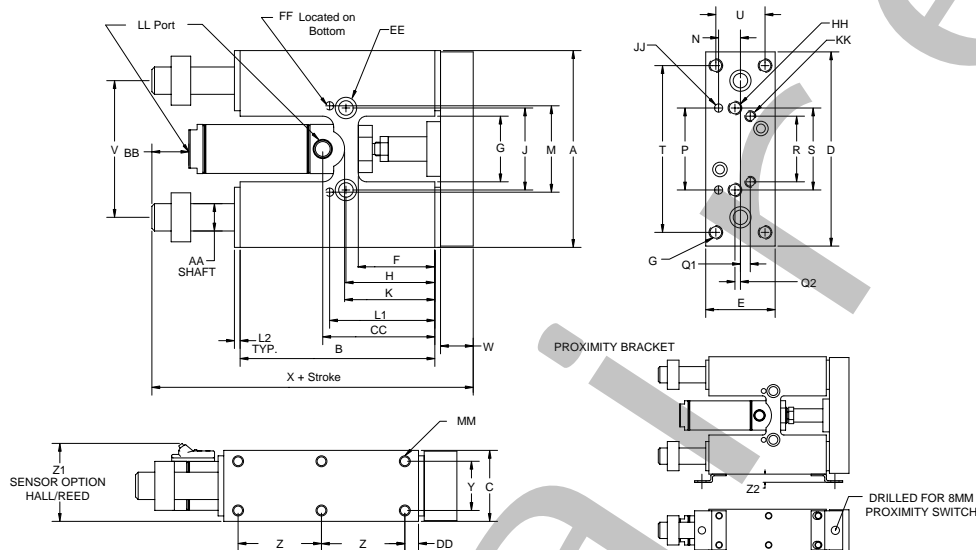

	SH150	SH200	SH250
A	5.25	6.50	6.50
B	4.95	6.50	6.50
C	2.00	2.50	2.87
D	5.18	6.44	6.44
E	1.93	2.44	2.44
F	1.93	2.50	2.50
G	2.00	2.50	2.50
H	2.25	2.87	2.81
J	2.25	2.75	2.75
K	2.68	3.37	3.37
L1	2.68	3.37	3.31
L2	0.18	0.25	0.25
M	2.499/2.501	2.99/3.001	2.999/3.001
N	0.56	0.62	0.62
P	2.499/2.501	2.999/3.001	2.999/3.001
Q1	0.31	0.37	0.37
Q2	0.12	0.12	0.12
R	1.87	2.25	2.25
S	2.25	2.75	2.75
T	4.25	5.25	5.25
U	1.43	1.87	1.87
V	3.75	4.56	4.56
W	0.81	0.87	0.87
X	7.16	8.75	8.75
Y	1.43	1.87	1.87
Z	2.12	2.62	2.62
Z1	2.25	2.75	3.21
Z2	0.312	.312	.312

	SH150	SH200	SH250
AA	0.750 Nom.	1.000 Nom.	1.000 Nom.
BB	0.87	1.00	1.00
CC	3.00	3.71	3.71
DD	0.37	0.62	0.62
EE	C'Bored for 5/16 SHCS, Tapped 3/8-24 x 0.75 DP From Opposite side	C'Bored for 3/8 SHCS, Tapped 7/16-20 x 0.875 DP From Opposite side	C'Bored for 3/8 SHCS, Tapped 7/16-20 x 0.875 DP From Opposite side
FF	0.1875/0.1885 x 0.37DP 5/16-18 thru, C'Bored for 1/4 SHCS From Opposite Side	0.250/0.251 x 0.50DP 3/8-24 thru, C'Bored for 5/16 SHCS From Opposite Side	0.250/0.251 x 0.50DP 3/8-24 thru, C'Bored for 5/16 SHCS From Opposite Side
GG	5/16-18 thru, C'Bored For 1/4 SHCS From Opposite Side	3/8-24 thru, C'Bored For 5/16 SHCS From Opposite Side	3/8-24 thru, C'Bored For 5/16 SHCS From Opposite Side
HH	0.1875/0.1885 x 0.37DP 5/16-18 x 0.62DP 1/8 NPTF	0.250/0.251 x 0.50DP 5/16-18 x 0.62DP 1/4 NPTF	0.250/0.251 x 0.50DP 5/16-18 x 0.62DP 1/4 NPTF



SH300 Slides

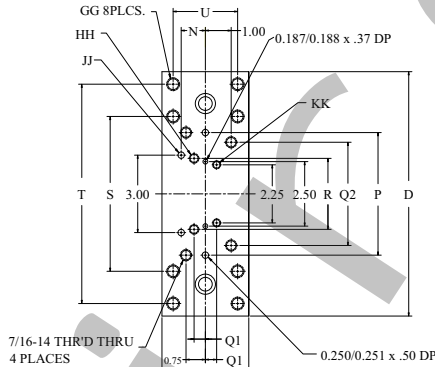
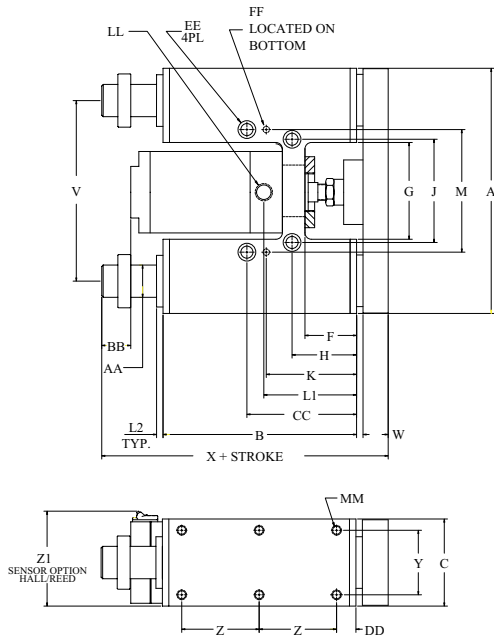

SH300	
A	9.50
B	7.50
C	3.37
D	9.44
E	3.31
F	2.00
G	3.75
H	2.50
J	4.00
K	3.50
L1	3.59
L2	0.25
M	4.749 / 4.751
N	0.94
P	4.749 / 4.751
Q1	0.43
Q2	4.00
R	2.75
S	6.00
T	8.50
U	2.50
V	7.00
W	0.97
X	10.10
Y	2.50
Z	3.00
Z1	3.73
Z2	0.312

SH300	
AA	1.250 Nom.
BB	1.12
CC	4.25
DD	0.75
EE	C'Bored for 7/16 SHCS, Tapped 1/2-3 x 0.75 DP From Opposite side
FF	0.250 / 0.251 x 0.50DP
GG	1/2-13 x .38 DP
HH	7/16-14 thru, C'Bored For 5/16 SHCS From Opposite Side
JJ	0.250 / 0.251 x 0.50DP
KK	5/16-18 x 0.50DP
LL	3/8 NPTF

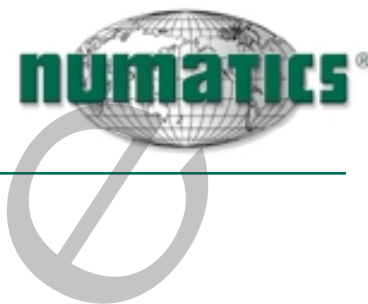

SH Series
Linear Slides

Maximum Dynamic Load and Deflection Ratings

Positions "A, B & C" Linear Bearing Option

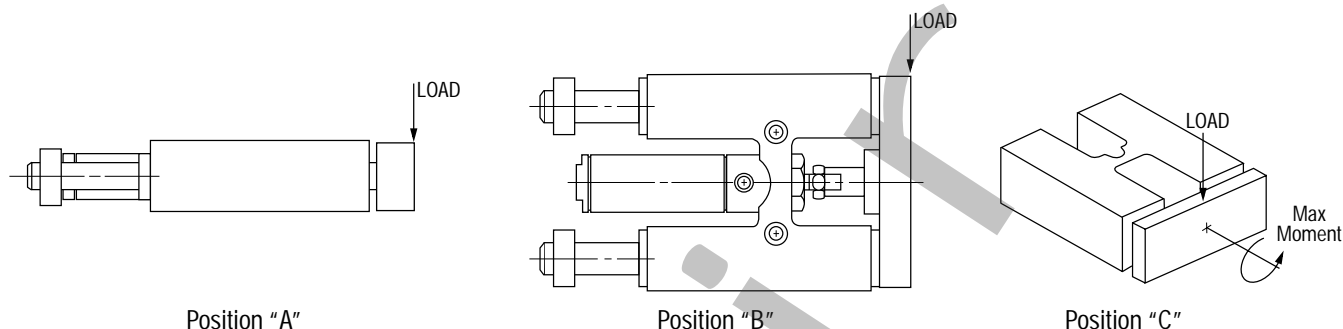

SH056					SH075					SH106			
Stroke Inches	Max. Load A & B (lbs.)	Deflection A (Inches)	Deflection B (Inches)	Max. Load C (Inlb.)	Max. Load A & B (lbs.)	Deflection A (Inches)	Deflection B (Inches)	Max. Load C (Inlb.)	Max. Load A & B (lbs.)	Deflection A (Inches)	Deflection B (Inches)	Max. Load C (Inlb.)	
1	30.9	0.001	0.001	30.9	55.0	0.001	0.001	55.0	97.0	0.001	0.001	97.0	
2	24.8	0.002	0.001	24.8	45.8	0.001	0.001	45.8	82.0	0.002	0.002	82.0	
3	20.1	0.004	0.003	20.1	39.2	0.003	0.002	39.2	71.1	0.004	0.003	71.1	
4	15.4	0.007	0.005	15.4	34.3	0.005	0.004	34.3	62.7	0.006	0.005	62.7	
5	9.4	0.008	0.006	9.4	30.5	0.008	0.006	30.5	54.1	0.009	0.007	54.1	
6	8.2	0.011	0.009	8.2	27.5	0.012	0.010	27.5	48.8	0.013	0.010	48.8	
7	7.2	0.016	0.012	7.2	24.3	0.017	0.013	24.3	41.3	0.019	0.015	41.3	
8	6.5	0.021	0.016	6.5	21.2	0.021	0.017	21.2	36.8	0.022	0.018	36.8	
9	5.7	0.026	0.021	5.7	19.8	0.028	0.022	19.8	30.6	0.023	0.019	30.6	
10	5.0	0.031	0.024	5.0	18.2	0.035	0.028	18.2	25.9	0.026	0.020	25.9	
11	4.1	0.032	0.026	4.1	16.8	0.043	0.034	16.8	22.1	0.029	0.023	22.1	
12	3.1	0.032	0.025	3.1	14.1	0.046	0.037	14.1	20.0	0.033	0.026	20.0	

SH150					SH200/SH250					SH300			
Stroke Inches	Max. Load A & B (lbs.)	Deflection A (Inches)	Deflection B (Inches)	Max. Load C (Inlb.)	Max. Load A & B (lbs.)	Deflection A (Inches)	Deflection B (Inches)	Max. Load C (Inlb.)	Max. Load A & B (lbs.)	Deflection A (Inches)	Deflection B (Inches)	Max. Load C (Inlb.)	
1	136.4	0.001	0.001	136.4	232.7	0.001	0.001	232.7	339.0	.001	.001	339.0	
2	116.7	0.001	0.001	116.7	200.0	0.001	0.001	200.0	297.6	.001	.001	297.6	
3	95.8	0.003	0.002	95.8	176.2	0.002	0.002	176.2	265.7	.002	.001	265.7	
4	86.2	0.004	0.003	86.2	153.6	0.003	0.003	153.6	235.6	.003	.002	235.6	
5	75.4	0.007	0.005	75.4	136.6	0.004	0.004	136.6	210.8	.004	.003	210.8	
6	65.0	0.009	0.007	65.0	110.3	0.005	0.004	110.3	190.0	.005	.003	190.0	
7	59.3	0.012	0.010	59.3	97.3	0.006	0.005	97.3	170.0	.006	.004	170.0	
8	53.3	0.015	0.012	53.3	86.0	0.008	0.007	86.0	154.0	.008	.005	154.0	
9	47.3	0.018	0.015	47.3	76.1	0.010	0.008	76.1	137.8	.009	.006	137.8	
10	40.1	0.021	0.017	40.1	68.2	0.011	0.009	68.2	123.7	.010	.007	123.7	
11	35.7	0.023	0.019	35.7	57.5	0.012	0.010	57.5	109.9	.012	.008	109.9	
12	29.1	0.024	0.020	29.1	48.7	0.013	0.011	48.7	96.9	.012	.009	96.9	
13	25.0	0.026	0.021	25.0	40.7	0.014	0.012	40.7	82.8	.013	.010	82.8	
14	22.1	0.028	0.022	22.1	30.8	0.013	0.011	30.8	72.4	.014	.011	72.4	
15	19.5	0.030	0.024	19.5	22.1	0.011	0.009	22.1	62.9	.015	.013	62.9	
16	16.6	0.030	0.024	16.6	17.6	0.011	0.009	17.6	54.2	.015	.013	54.2	
17	14.0	0.030	0.024	14.0	15.0	0.009	0.007	15.0	46.3	.015	.013	46.3	
18	10.1	0.026	0.021	10.1	12.0	0.007	0.006	12.0	39.1	.015	.013	39.1	

* SH031 Series not offered in Linear Ball Bearing Option.
Maximum load and deflection ratings, 100% at tool plate mounting face



SH Series
Linear Slides

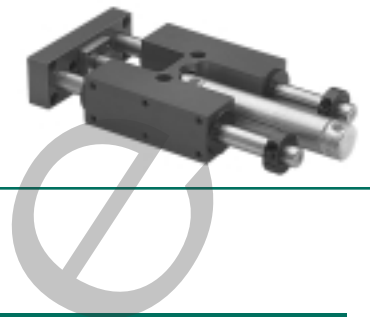

Maximum Dynamic Load and Deflection Ratings
Positions "A, B & C" Bronze Bearing and Teflon® Bearing Options

SH031*					SH056				SH075			
Stroke Inches	Max. Load A & B (lbs.)	Deflection A (Inches)	Deflection B (Inches)	Max. Load C (Inlb.)	Max. Load A & B (lbs.)	Deflection A (Inches)	Deflection B (Inches)	Max. Load C (Inlb.)	Max. Load A & B (lbs.)	Deflection A (Inches)	Deflection B (Inches)	Max. Load C (Inlb.)
0.5	5.0	0.001	0.001	5.0	N/A	N/A	N/A	N/A	N/A	N/A	N/A	N/A
1	4.5	0.001	0.001	4.5	20.1	0.001	0.001	20.1	35.7	0.001	0.001	35.7
1.5	4.0	0.001	0.001	4.0	N/A	N/A	N/A	N/A	N/A	N/A	N/A	N/A
2	3.5	0.001	0.001	3.5	16.1	0.001	0.001	16.1	29.8	0.001	0.001	29.8
3	2.7	0.002	0.002	2.7	13.0	0.003	0.002	13.0	25.4	0.002	0.001	25.4
4	1.9	0.004	0.003	1.9	10.1	0.004	0.003	10.1	22.3	0.003	0.003	22.3
5	1.1	0.004	0.003	1.1	6.2	0.005	0.004	6.2	19.8	0.005	0.004	19.8
6	0.5	0.004	0.003	0.5	5.3	0.007	0.006	5.3	17.8	0.008	0.006	17.8
7	N/A	N/A	N/A	N/A	4.6	0.010	0.008	4.6	15.7	0.011	0.009	15.7
8	N/A	N/A	N/A	N/A	4.2	0.013	0.011	4.2	13.7	0.014	0.011	13.7
9	N/A	N/A	N/A	N/A	3.7	0.017	0.013	3.7	12.8	0.018	0.014	12.8
10	N/A	N/A	N/A	N/A	3.2	0.020	0.016	3.2	11.8	0.023	0.018	11.8
11	N/A	N/A	N/A	N/A	2.6	0.021	0.017	2.6	10.9	0.028	0.022	10.9
12	N/A	N/A	N/A	N/A	1.9	0.020	0.016	1.9	9.1	0.030	0.024	9.1

SH106					SH150				SH200/SH250			
Stroke Inches	Max. Load A & B (lbs.)	Deflection A (Inches)	Deflection B (Inches)	Max. Load C (Inlb.)	Max. Load A & B (lbs.)	Deflection A (Inches)	Deflection B (Inches)	Max. Load C (Inlb.)	Max. Load A & B (lbs.)	Deflection A (Inches)	Deflection B (Inches)	Max. Load C (Inlb.)
1	48.5	0.001	0.001	48.5	68.2	0.001	0.001	68.2	116.3	0.001	0.001	116.3
2	41.1	0.001	0.001	41.0	58.3	0.001	0.001	58.3	100.0	0.001	0.001	100.0
3	35.5	0.002	0.002	35.5	51.0	0.001	0.001	51.0	88.1	0.001	0.001	88.1
4	31.3	0.003	0.002	31.3	43.1	0.002	0.002	43.1	76.8	0.001	0.001	76.8
5	27.0	0.005	0.003	27.0	37.7	0.003	0.003	37.7	68.3	0.002	0.002	68.3
6	24.4	0.006	0.005	24.4	32.5	0.004	0.004	32.5	55.1	0.003	0.003	55.1
7	20.6	0.008	0.006	20.6	29.6	0.006	0.005	29.6	48.6	0.003	0.003	48.6
8	18.4	0.010	0.008	18.4	26.6	0.008	0.006	26.6	43.0	0.004	0.003	43.0
9	15.3	0.012	0.009	15.3	23.6	0.009	0.007	23.6	38.0	0.005	0.004	38.0
10	12.9	0.013	0.010	12.9	20.0	0.010	0.008	20.0	34.1	0.006	0.005	34.1
11	11.0	0.014	0.011	11.0	17.8	0.012	0.009	17.8	28.7	0.006	0.005	28.7
12	10.1	0.016	0.013	10.1	14.5	0.012	0.010	14.5	24.3	0.007	0.006	24.3
13	N/A	N/A	N/A	N/A	12.5	0.013	0.010	12.5	20.3	0.007	0.006	20.3
14	N/A	N/A	N/A	N/A	11.0	0.014	0.011	11.0	15.4	0.007	0.006	15.4
15	N/A	N/A	N/A	N/A	9.7	0.015	0.012	9.7	11.0	0.006	0.005	11.0
16	N/A	N/A	N/A	N/A	8.3	0.015	0.012	8.3	8.8	0.005	0.004	8.8
17	N/A	N/A	N/A	N/A	7.0	0.015	0.012	7.0	7.5	0.004	0.003	7.5
18	N/A	N/A	N/A	N/A	5.0	0.013	0.011	5.0	6.0	0.004	0.003	6.0

SH300				
Stroke Inches	Max. Load A & B (lbs.)	Deflection A (Inches)	Deflection B (Inches)	Max. Load C (Inlb.)
1	170.5	0.001	0.001	170.5
2	149.8	0.001	0.001	149.8
3	132.5	0.001	0.001	132.5
4	117.5	0.001	0.001	117.5
5	105.0	0.002	0.001	105.0
6	95.4	0.002	0.002	95.4
7	85.2	0.003	0.002	85.2
8	77.7	0.004	0.003	77.7
9	69.0	0.005	0.004	69.0
10	62.3	0.005	0.004	62.3
11	55.1	0.006	0.005	55.1
12	48.0	0.006	0.005	48.0
13	41.7	0.007	0.006	41.7
14	36.0	0.007	0.006	36.0
15	31.5	0.008	0.007	31.5
16	27.9	0.008	0.007	27.9
17	23.0	0.009	0.008	23.0
18	19.5	0.009	0.008	19.5

* SH031 Series not offered in Linear Ball Bearing Option.
Maximum load and deflection ratings, 100% at tool plate mounting face



SH Series Linear Slides

Unit Weight Table

	SH031	SH056	SH075	SH106	SH150	SH200	SH250	SH300
Base Unit Weight (lbs.)	0.35	1.07	2.46	4.04	6.36	12.94	13.84	30.12
Adder/inch of stroke (lbs.)	0.03	0.08	0.15	0.22	0.34	0.60	0.90	1.75

Add base weight to inch adder X stroke. sample weight calculation: Model SH075 W/6" stroke, $2.46 + (0.15 \times 6) = 3.360$ lbs.

Unit Output Force Table

	SH031	SH056	SH075	SH106	SH150	SH200	SH250	SH300
Extend Force (lbs.)	0.07	0.24	0.44	0.88	1.76	3.14	4.90	7.00
Retract Force (lbs.)	0.06	0.22	0.39	0.81	1.61	2.83	4.60	6.62

Multiply force factor X input pressure in PSI. sample output force calculation: Model SH150 extend force @ 70PSI, $1.76 \times 70 = 123.2$ lbs.

Shock Option

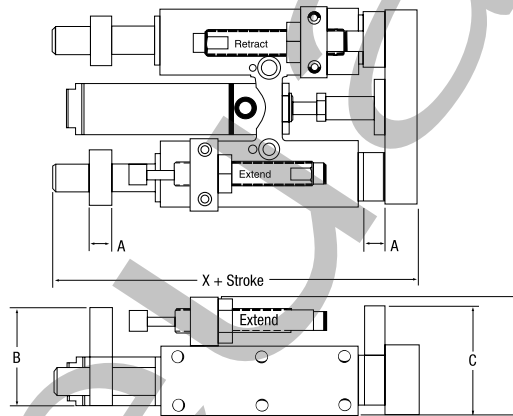

Dimensions

DIMENSION	SH075	SH106	SH150	SH200	SH250	SH300
A	0.44	0.50	0.50	0.50	0.50	0.50
B	2.00	2.25	2.75	3.25	3.52	5.50
C	2.13	2.50	3.13	3.75	3.93	5.75
D	2.38	2.75	3.25	3.88	4.25	5.87
X	6.68	7.31	8.13	9.75	9.75	11.10

* Shock Option available on SH075 series and larger.



SH Series
Linear Slides



MB Series Base Mounting

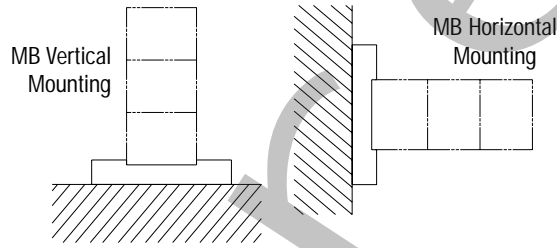
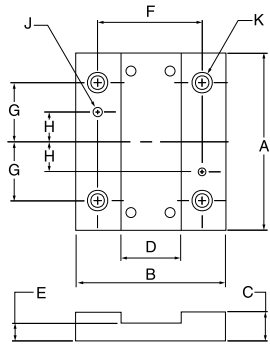

SLIDE SERIES	SH031	SH056	SH075	SH106	SH150	SH200
BASE P/N	MB031	MB056	MB075	MB106	MB150	MB200
A	2.00	3.00	4.00	4.50	5.00	6.50
B	1.62	2.50	3.00	3.50	4.00	5.00
C	0.34	0.47	0.59	.070	0.70	0.99
D	0.626/0.628	1.001/1.003	1.251/1.253	1.626/1.628	2.001/2.003	2.501/2.503
E	0.26	0.34	0.50	0.56	0.56	0.68
F	1.12	1.75	2.00	2.50	3.00	3.75
G	0.75	1.00	1.50	1.75	2.00	2.50
H	0.37	0.50	0.75	1.12	1.25	1.50
J	0.125/0.126	0.156/0.157	0.156/0.157	0.188/0.189	0.188/0.189	0.250/0.251
K	Clearance for #8 SHCS	Clearance for #10 SHCS	Clearance for 1/4 SHCS	Clearance for 5/16 SHCS	Clearance for 5/16 SHCS	Clearance for 3/8 SHCS

AB Series Angle Mounting — Not Available on SH300

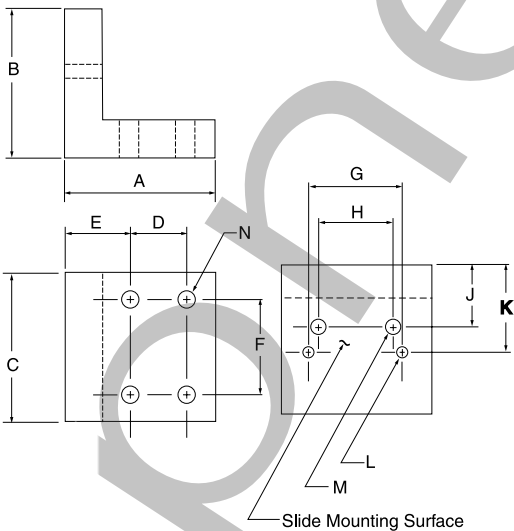
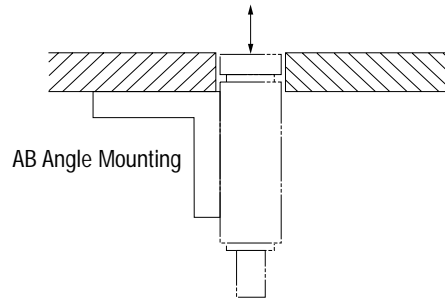

SLIDE SERIES	SH031	SH056	SH075	SH106	SH150	SH200/SH250
BASE P/N	AB031	AB056	AB075	AB106	AB150	AB200
A	1.25	2.00	2.50	3.00	3.50	4.00
B	1.25	2.00	2.50	3.00	3.50	4.00
C	1.75	2.25	2.75	3.25	4.00	5.00
D	0.50	0.87	1.00	1.25	1.50	2.00
E	0.50	0.62	0.75	1.12	1.25	1.37
F	1.25	1.25	1.75	2.25	3.00	4.00
G	1.00	1.37	1.81	1.87	2.50	3.00
H	1.00	1.25	1.50	1.87	2.25	2.75
J	0.75	1.00	1.31	1.78	2.00	2.37
K	0.97	1.31	1.68	2.15	2.43	2.87
L	0.94	0.125	0.187	0.187	0.187	0.250
M	For #10-32 SHCS	For 1/4-28 SHCS	For 5/16-24 SHCS	For 3/8-24 SHCS	For 3/8-24 SHCS	For 7/16-20 SHCS
N	For #10 SHCS	For 1/4 SHCS	For 5/16 SHCS	For 3/8 SHCS	For 3/8 SHCS	For 7/16 SHCS



SH Series
Linear Slides

NuMate™ Direct Mount, Mounting System

The *NuMate™* mounting system provides a standard series of drilled, tapped and counterbored holes allowing each slide series to mount with each other and other slide series in various combinations without the use of adapters, transition plates or other costly methods. The *NuMate™* mounting system also utilizes dowel hole locations for precision mountings. The *NuMate™* mounting system is the most versatile mounting method of its kind, providing customers with a cost effective method for building modular component automation. The *NuMate™* mounting system is consistent across the *NMC* spectrum of products for automation.

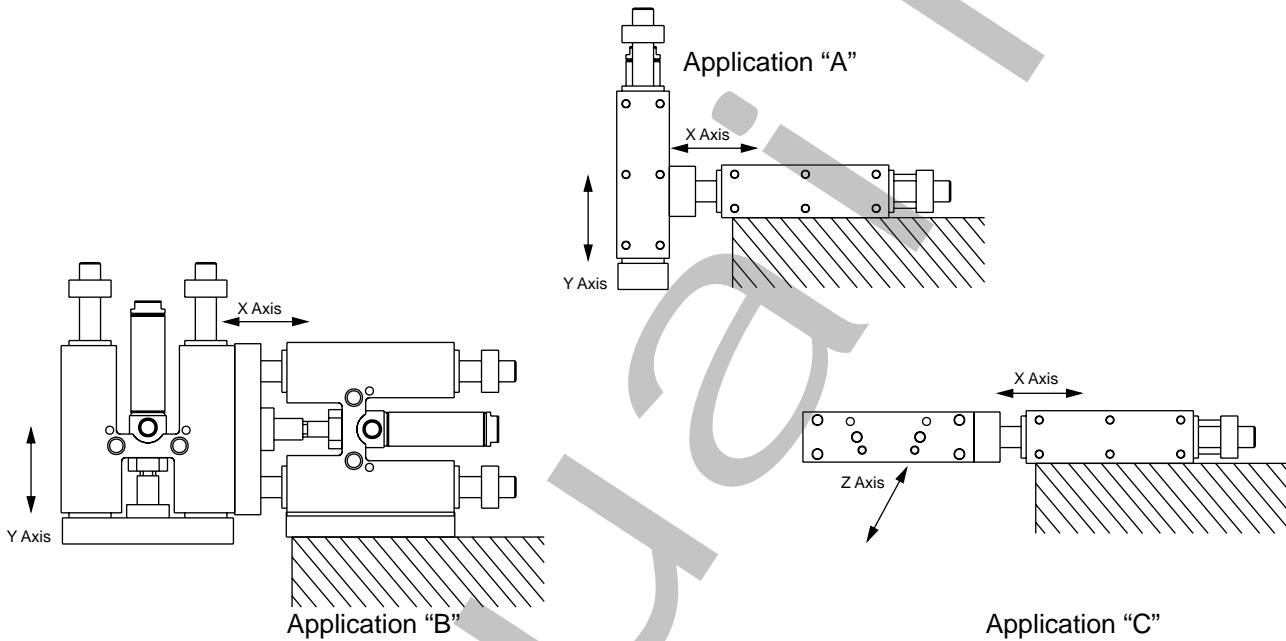

	APPLICATION A	APPLICATION B	APPLICATION C
X-AXIS SLIDE	MATING Y AXIS SLIDE	MATING Y AXIS SLIDE	MATING Z AXIS SLIDE
SH031	SH031		
SH056	SH031 SH056	SH056	SH056
SH075	SH056 SH075	SH075	SH075
SH106	SH075 SH106	SH106	SH106
SH150	SH106 SH150	SH150	SH150
SH200	SH150 SH200	SH200	SH200
SH250	SH150 SH200 SH250	SH200 SH250	SH200 SH250
SH300	SH150 SH200 SH250 SH300	SH300	SH300

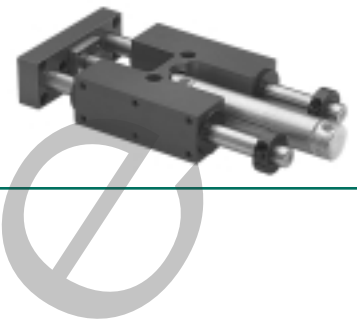

How to Order

3 Position Linear Slide

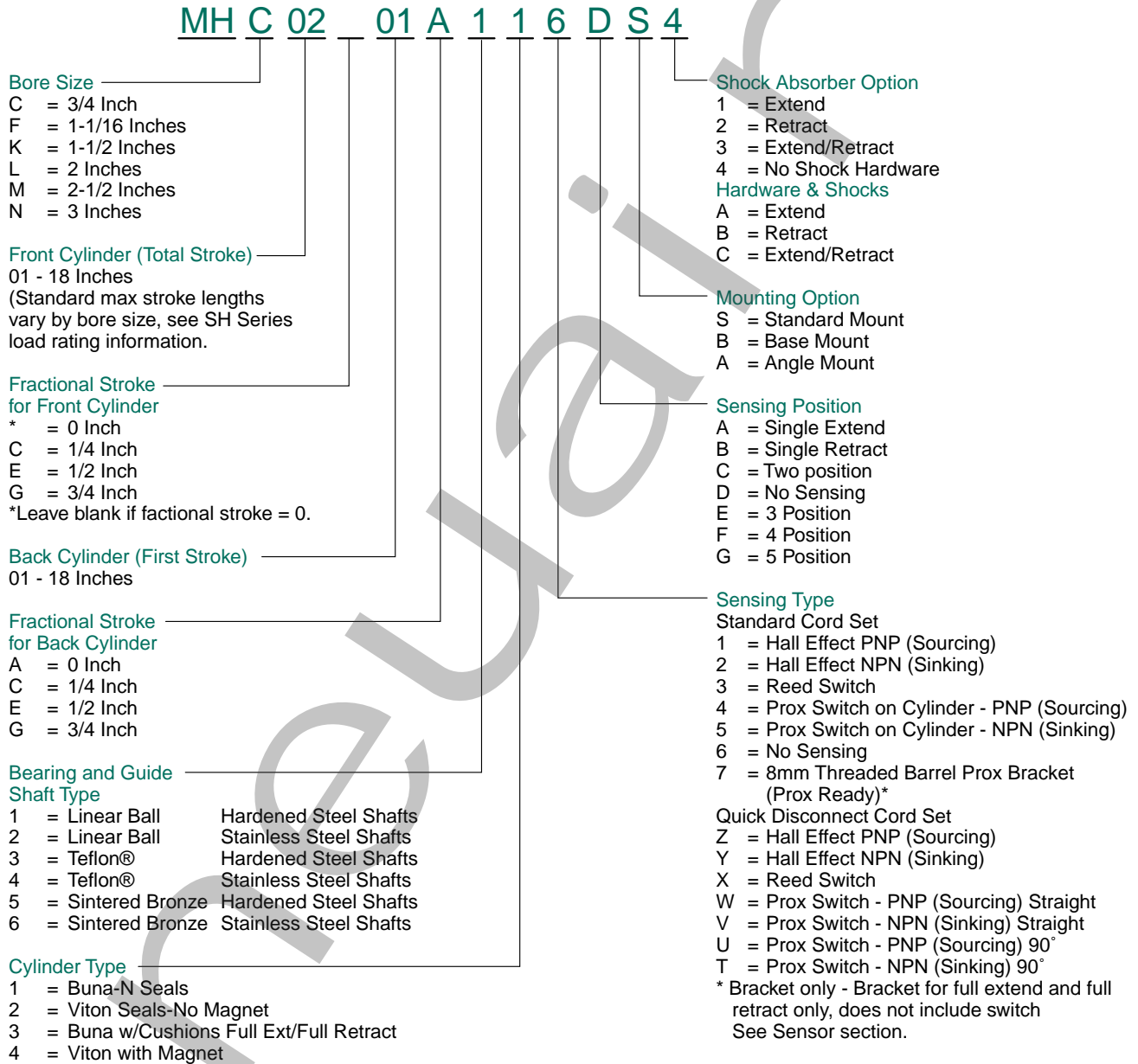



SH Series
Linear Slides

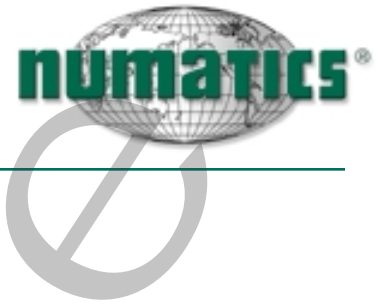

3 Position Linear Slide

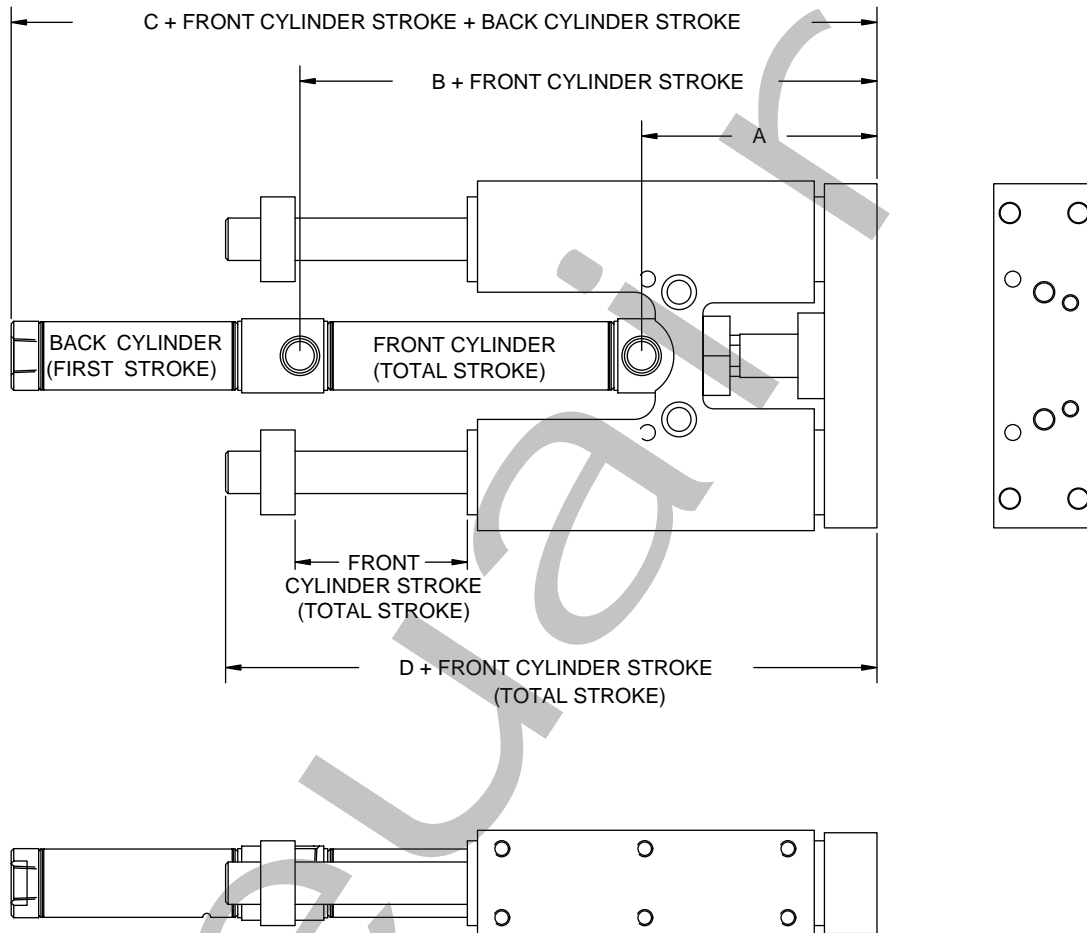

Dimensions - Inches

SH SERIES	A	B	C	D
SH075	2.78	4.81	7.21	5.68
SH106	3.44	5.47	8.04	6.35
SH150	3.86	5.99	8.80	7.16
SH200	4.85	7.57	11.05	8.75