

ORDER  
ONLINE



Cylinders



# ***Universal Series***

***Metric Compact Interchangeable Cylinder Line***

*We're everywhere you need us to be!*



## Universal Series

Features and Benefits	3-35
How to Order	3
Standard Stroke Chart	4
Double Acting, Single Rod	5
Double Acting, Double Rod	6-7
Double Acting, Non-Rotating Piston Rod	8-9
Double Acting, Double Rod, Non-Rotating Piston Rod	10-11
Double Acting, Double Rod, Non-Rotating Piston Rod	12-13
Single Acting, Spring Retract/Spring Extend	14-15
Magnetic Piston, Double Acting, Single Rod	16-17
Magnetic Piston, Double Acting, Double Rod	18-19
Magnetic Piston, Double Acting, Non-Rotating Piston Rod	20-21
Magnetic Piston, Double Acting, Double Rod, Non-Rotating Piston Rod	22-23
Magnetic Piston Adjustable Extend Stroke	24-25
Rear Clevis Mount	26
Foot Mounts	27
Flange Mounts	28
Front and Rear Boss Mounts	29
Accessories	30
U Series with Guide Plate-Features and Benefits	31
Engineering Data	32
UT Series, Guided Toolplate	33-35



## Universal Series Metric Compact Interchangeable



The **Universal Series** is a compact, extruded aluminum body air cylinder line that is designed to meet all of your international compact cylinder requirements. The Universal Series minimizes overall space requirements through enabling precise, direct mounting in the smallest amount of space possible. The Universal Series includes a multitude of value-added standard design features, i.e., hard anodized extruded aluminum tubing, hard chrome plated stainless steel piston rods, an extra long high performance composite rod bushing, etc. These are just a sample of things that make the Universal Series the *Superior Interchangeable* metric, compact air cylinder line.

### Standard Specifications:

- Bore sizes from 12 mm through 160 mm
- Strokes from 5 mm to 300 mm
- Nominal pressure rating is 10 bar (150 psi)
- 3 port choices:
  - ~ NPT
  - ~ BSP Parallel
  - ~ BSP Tapered
- Flexible rod end options:
  - ~ Female with wrench flats
  - ~ Male rod with wrench flats and jam nut
- Metric or Inch rod threads and mounting threads
- Multitude of different actuation options:
  - ~ Double acting, single rod
  - ~ Double acting, double rod
  - ~ Non-rotating, double acting, single rod
  - ~ Non-rotating, double acting, double rod
  - ~ Single acting, single rod, spring return
  - ~ Single acting, single rod, spring extended
- Magnetic piston option
- Complete range of mounting accessories:
  - ~ Flange mounts
    - Head and cap
  - ~ Clevis mounts
    - Rear clevis, Rod clevis, Rod eye
  - ~ Boss mounts
    - Head and Cap
  - ~ Foot mounts
- Adjustable stroke models
- 3-position and 4-position models
- Bumper option
- Seal material deviation



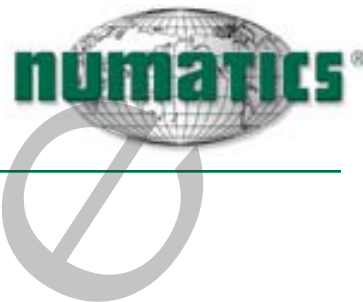

Universal Series  
Metric Compact Interchangeable

How To Order

**U N D - S E 020 - 010 D - M**

Series

U = Universal Series  
Metric Compact Interchangeable

Port

G = BSP Parallel Ports,  
Metric Rod Thread  
N = NPT Ports, Inch Rod Thread  
P = BSPT Taper Ports,  
Metric Rod Threads

Body

D\* = With Magnetic Piston  
N = Without Magnetic Piston  
\*Adds to the OAL of the cylinder.

Model

A = Adjustable Stroke Extend  
AK = Adjustable Stroke Extend  
Non-Rotating Rod  
K = Non-Rotating Single Rod  
L = Non-Rotating Double Rod  
M = Non-Rotating Double Rod Hole Thru  
S = Single Rod  
T = Double Rod Hole Thru  
W = Double Rod

Mounting

A = Tapped Both Ends  
B = Thru Hole  
C = Rear Clevis  
E = Flange Rod End  
F = Flange Cap End  
G = ISO Flange Rod End  
H = ISO Flange Cap End  
L = Foot Mount

Options

(Leave blank if no options are desired.)

B = Bumpers, Both Ends  
(Standard Feature on  
125, 140, 160 Bores)  
E = Boss, Rod End  
F = Boss, Cap End  
M = Male Rod, Rod End  
N = Male Rod, Cap End  
P = Male Rod, Both Ends  
RS\* = Adjustable Stroke, Retract  
V = High Temperature Seals  
XC10 = Back-to-Back  
XC11 = Tandem (Mounting at Rod End)  
XC12 = Tandem (Mounting at Cap End)  
\*Not valid with A or AK models or double rod models.

Actuation

D = Double Acting  
S = Single Acting, Spring Retract  
(12 mm through 50 mm bores only)  
T = Single Acting, Spring Extend  
(12 mm through 50 mm bores only)

Stroke

005 = 5 mm  
010 = 10 mm  
100 = 100 mm  
150 = 150 mm  
300 = 300 mm

Standard Stroke Chart

12 mm - 25 mm Bore = 5 mm to 100 mm Stroke  
32 mm and 40 mm Bore = 5 mm to 150 mm Stroke  
50 mm - 100 mm Bore = 10 mm to 150 mm Stroke  
125 mm - 160 mm Bore = 10 mm to 300 mm Stroke

Bore

012 = 12 mm	063 = 63 mm
016 = 16 mm	080 = 80 mm
020 = 20 mm	100 = 100 mm
025 = 25 mm	125 = 125 mm
032 = 32 mm	140 = 140 mm
040 = 40 mm	160 = 160 mm
050 = 50 mm	

NOTE: See page 5 for stroke and bore compatibility information.



Universal Series  
Metric Compact Interchangeable



Standard Stroke

Features and Options

BORE SIZE (mm)	STROKE (mm)																	MOUNTING OPTIONS			CYLINDER OPTIONS								
	5	10	15	20	25	30	35	40	45	50	75	100	125	150	175	200	250	300	STANDARD SERIES	MAGNETIC PISTON SERIES	TAPPED HOLE	FLANGE	FOOT	REAR CLEVIS	FRONT BOSS	REAR BOSS	MALE ROD END	ADJUSTABLE STROKE	HIGH TEMP SEALS
<b>DOUBLE ACTING SINGLE ROD</b>																													
12	◆	◆	◆	◆	◆					◆	◆	◆							◆	◆	◆	◆	◆	◆	◆				
16	◆	◆	◆	◆	◆					◆	◆	◆							◆	◆	◆	◆	◆	◆	◆				
20	◆	◆	◆	◆	◆	◆	◆	◆	◆	◆	◆	◆	◆	◆	◆	◆	◆	◆	◆	◆	◆	◆	◆	◆	◆				
25	◆	◆	◆	◆	◆	◆	◆	◆	◆	◆	◆	◆	◆	◆	◆	◆	◆	◆	◆	◆	◆	◆	◆	◆	◆				
32	◆	◆	◆	◆	◆	◆	◆	◆	◆	◆	◆	◆	◆	◆	◆	◆	◆	◆	◆	◆	◆	◆	◆	◆	◆				
40	◆	◆	◆	◆	◆	◆	◆	◆	◆	◆	◆	◆	◆	◆	◆	◆	◆	◆	◆	◆	◆	◆	◆	◆	◆				
50		◆	◆	◆	◆	◆	◆	◆	◆	◆	◆	◆	◆	◆	◆	◆	◆	◆	◆	◆	◆	◆	◆	◆	◆				
63		◆	◆	◆	◆	◆	◆	◆	◆	◆	◆	◆	◆	◆	◆	◆	◆	◆	◆	◆	◆	◆	◆	◆	◆				
80		◆	◆	◆	◆	◆	◆	◆	◆	◆	◆	◆	◆	◆	◆	◆	◆	◆	◆	◆	◆	◆	◆	◆	◆				
100		◆	◆	◆	◆	◆	◆	◆	◆	◆	◆	◆	◆	◆	◆	◆	◆	◆	◆	◆	◆	◆	◆	◆	◆				
125		◆		◆		◆		◆		◆		◆		◆		◆		◆	◆	◆	◆	◆	◆	◆	◆				
140		◆		◆		◆		◆		◆		◆		◆		◆		◆	◆	◆	◆	◆	◆	◆	◆				
160		◆		◆		◆		◆		◆		◆		◆		◆		◆	◆	◆	◆	◆	◆	◆	◆				
<b>DOUBLE ACTING DOUBLE ROD</b>																													
12	◆	◆	◆	◆	◆					◆	◆	◆							◆	◆	◆	◆	◆	◆	◆				
16	◆	◆	◆	◆	◆					◆	◆	◆							◆	◆	◆	◆	◆	◆	◆				
20	◆	◆	◆	◆	◆	◆	◆	◆	◆	◆	◆	◆	◆	◆	◆	◆	◆	◆	◆	◆	◆	◆	◆	◆	◆				
25	◆	◆	◆	◆	◆	◆	◆	◆	◆	◆	◆	◆	◆	◆	◆	◆	◆	◆	◆	◆	◆	◆	◆	◆	◆				
32	◆	◆	◆	◆	◆	◆	◆	◆	◆	◆	◆	◆	◆	◆	◆	◆	◆	◆	◆	◆	◆	◆	◆	◆	◆				
40	◆	◆	◆	◆	◆	◆	◆	◆	◆	◆	◆	◆	◆	◆	◆	◆	◆	◆	◆	◆	◆	◆	◆	◆	◆				
50		◆	◆	◆	◆	◆	◆	◆	◆	◆	◆	◆	◆	◆	◆	◆	◆	◆	◆	◆	◆	◆	◆	◆	◆				
63		◆	◆	◆	◆	◆	◆	◆	◆	◆	◆	◆	◆	◆	◆	◆	◆	◆	◆	◆	◆	◆	◆	◆	◆				
80		◆	◆	◆	◆	◆	◆	◆	◆	◆	◆	◆	◆	◆	◆	◆	◆	◆	◆	◆	◆	◆	◆	◆	◆				
100		◆	◆	◆	◆	◆	◆	◆	◆	◆	◆	◆	◆	◆	◆	◆	◆	◆	◆	◆	◆	◆	◆	◆	◆				
125		◆		◆		◆		◆		◆		◆		◆		◆		◆	◆	◆	◆	◆	◆	◆	◆				
140		◆		◆		◆		◆		◆		◆		◆		◆		◆	◆	◆	◆	◆	◆	◆	◆				
160		◆		◆		◆		◆		◆		◆		◆		◆		◆	◆	◆	◆	◆	◆	◆	◆				
<b>DOUBLE ACTING SINGLE ROD NON-ROTATING</b>																													
<b>DOUBLE ACTING DOUBLE ROD NON-ROTATING</b>																													
12	◆	◆	◆	◆	◆					◆	◆	◆							◆	◆	◆	◆	◆	◆	◆				
16	◆	◆	◆	◆	◆					◆	◆	◆							◆	◆	◆	◆	◆	◆	◆				
20	◆	◆	◆	◆	◆	◆	◆	◆	◆	◆	◆	◆	◆	◆	◆	◆	◆	◆	◆	◆	◆	◆	◆	◆	◆				
25	◆	◆	◆	◆	◆	◆	◆	◆	◆	◆	◆	◆	◆	◆	◆	◆	◆	◆	◆	◆	◆	◆	◆	◆	◆				
32	◆	◆	◆	◆	◆	◆	◆	◆	◆	◆	◆	◆	◆	◆	◆	◆	◆	◆	◆	◆	◆	◆	◆	◆	◆				
40	◆	◆	◆	◆	◆	◆	◆	◆	◆	◆	◆	◆	◆	◆	◆	◆	◆	◆	◆	◆	◆	◆	◆	◆	◆				
50		◆	◆	◆	◆	◆	◆	◆	◆	◆	◆	◆	◆	◆	◆	◆	◆	◆	◆	◆	◆	◆	◆	◆	◆				
63		◆	◆	◆	◆	◆	◆	◆	◆	◆	◆	◆	◆	◆	◆	◆	◆	◆	◆	◆	◆	◆	◆	◆	◆				
80		◆	◆	◆	◆	◆	◆	◆	◆	◆	◆	◆	◆	◆	◆	◆	◆	◆	◆	◆	◆	◆	◆	◆	◆				
100		◆	◆	◆	◆	◆	◆	◆	◆	◆	◆	◆	◆	◆	◆	◆	◆	◆	◆	◆	◆	◆	◆	◆	◆				
<b>SINGLE ACTING SPRING RETRACT</b>																													
12	◆	◆																	◆	◆	◆	◆	◆	◆	◆				
16	◆	◆																	◆	◆	◆	◆	◆	◆	◆				
20	◆	◆																	◆	◆	◆	◆	◆	◆	◆				
25	◆	◆																	◆	◆	◆	◆	◆	◆	◆				
32	◆	◆																	◆	◆	◆	◆	◆	◆	◆				
40	◆	◆																	◆	◆	◆	◆	◆	◆	◆				
50		◆																	◆	◆	◆	◆	◆	◆	◆				
<b>SINGLE ACTING SPRING EXTEND</b>																													
12	◆	◆																	◆	◆	◆	◆	◆	◆	◆				
16	◆	◆																	◆	◆	◆	◆	◆	◆	◆				
20	◆	◆																	◆	◆	◆	◆	◆	◆	◆				
25	◆	◆																	◆	◆	◆	◆	◆	◆	◆				
32	◆	◆																	◆	◆	◆	◆	◆	◆	◆				





Universal Series  
Metric Compact Interchangeable

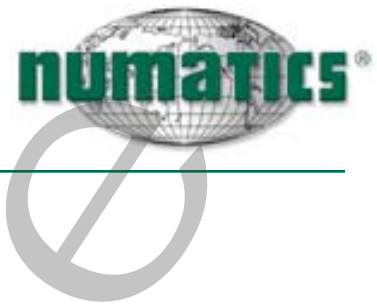

Double Acting, Single Rod

Ø12 - Ø16 mm Bores

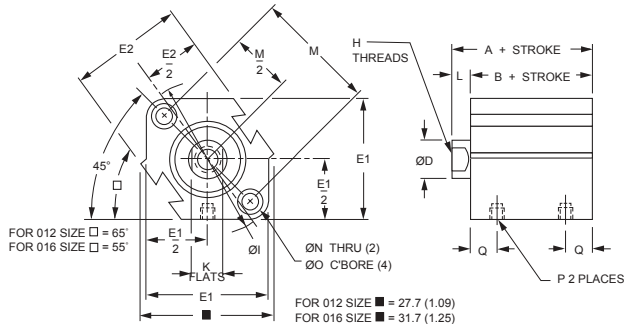

Ø20 - Ø25 mm Bores

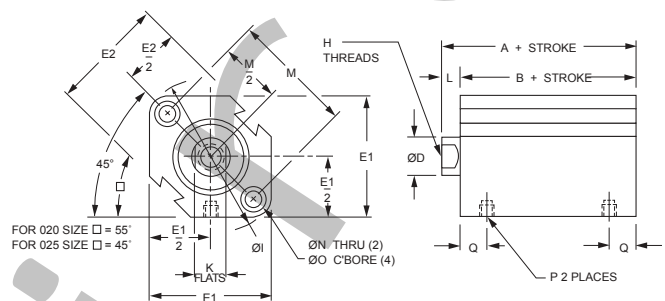

BORE MM	LONG STROKE				EXTENDED STROKE			
	STROKE MM	A	B	Q	STROKE MM	A	B	Q
12	—	—	—	—	50, 75,	37.3	33.8	8.9
	—	—	—	—	100	(1.47)	(1.33)	(0.35)
16	—	—	—	—	50, 75,	39.7	36.2	10.2
	—	—	—	—	100	(1.56)	(1.42)	(0.40)
20	—	—	—	—	75, 100	46.1	41.6	12.1
	—	—	—	—	—	(1.82)	(1.64)	(0.48)
25	—	—	—	—	75, 100	52.5	47.5	12.7
	—	—	—	—	—	(2.07)	(1.87)	(0.50)
32	75, 100	40.0	33.0	8.7	125, 150	54.8	47.8	12.7
	—	(1.57)	(1.30)	(0.34)	—	(2.16)	(1.88)	(0.50)
40	75, 100	46.5	39.5	9.2	125, 150	62.5	55.5	12.7
	—	(1.83)	(1.56)	(0.36)	—	(2.46)	(2.19)	(0.50)
50	75, 100	48.5	40.5	10.5	125, 150	67.3	59.3	13.2
	—	(1.91)	(1.59)	(0.41)	—	(2.65)	(2.33)	(0.52)
63	75, 100	54.0	46.0	11.5	125, 150	72.6	64.6	18.5
	—	(2.13)	(1.81)	(0.45)	—	(2.86)	(2.54)	(0.73)
80	75, 100	63.5	53.5	14.0	125, 150	79.5	69.5	14.0
	—	(2.50)	(2.11)	(0.55)	—	(3.13)	(2.74)	(0.55)
100	75, 100	75.0	63.0	18.0	125, 150	88.7	76.7	18.0
	—	(2.95)	(2.48)	(0.71)	—	(3.49)	(3.02)	(0.71)

NOTE: See page 5 for complete stroke availability.

Dimensions measurements in millimeters and inches (in parenthesis)

BORE	STROKE	A	B	ØD	E1	E2	H (THREADS X dp MIN.)	ØI
12 (1/2)	5-30 (0.20-1.18)	20.5 (0.81)	17.0 (0.67)	6.0 (0.24)	25.0 (0.98)	23.0 (0.90)	#8-32 x 0.21dp (M3 x 0.5 - 5dp)	31.5 (1.24)
16 (5/8)	5-30 (0.20-1.18)	22.0 (0.87)	18.5 (0.73)	8.0 (0.32)	29.0 (1.14)	27.2 (1.07)	#8-32 X 0.21dp (M4 x 0.7 - 5dp)	37.1 (1.46)
20 (3/4)	5-50 (0.20-2.0)	24.0 (0.94)	19.5 (0.77)	10.0 (0.39)	36.0 (1.42)	31.2 (1.23)	#10-32 X 0.28dp (M5 x 0.8 - 7dp)	47.0 (1.85)
25 (1)	5-50 (0.20-2.0)	27.5 (1.08)	22.5 (0.89)	12.0 (0.47)	40.0 (1.57)	36.9 (1.45)	1/4-28 X 0.39dp (M6 x 1.0 - 10dp)	51.3 (2.02)
32 (1-1/4)	5 only (0.20)	30.0 (1.18)	23.0 (0.91)	16.0 (0.63)	44.5 (1.75)	—	5/16-24 X 0.50dp (M8 x 1.25 - 12dp)	58.9 (2.32)
	10-50 (0.39-2.0)	30.0 (1.18)	23.0 (0.91)	16.0 (0.63)	44.5 (1.75)	—	5/16-24 X 0.50dp (M8 x 1.25 - 12dp)	58.9 (2.32)
40 (1-1/2)	5-50 (0.20-2.0)	36.5 (1.44)	29.5 (1.16)	16.0 (0.63)	52.0 (2.05)	—	3/8-24 X 0.50dp (M8 x 1.25 - 12dp)	69.0 (2.72)
50 (2)	10-50 (0.39-2.0)	38.5 (1.52)	30.5 (1.20)	20.0 (0.79)	63.7 (2.51)	—	1/2-20 X 0.50dp (M10 x 1.5 - 12dp)	84.9 (3.34)
63 (2-1/2)	10-50 (0.39-2.0)	44.0 (1.73)	36.0 (1.42)	20.0 (0.79)	76.7 (3.02)	—	1/2-20 X 0.50dp (M10 x 1.5 - 12dp)	101.8 (4.01)
80 (3-1/4)	10-50 (0.39-2.0)	53.5 (2.11)	43.5 (1.71)	25.0 (0.98)	97.8 (3.85)	—	5/8-18 X 0.88dp (M16 x 2.0 - 22dp)	129.8 (5.11)
100 (4)	10-50 (0.39-2.0)	65.0 (2.56)	53.0 (2.09)	30.0 (1.18)	115.3 (4.54)	—	3/4-16 X 0.88dp (M20 x 2.5 - 22dp)	153.9 (6.06)
125 (4.9)	10-300 (0.39-12)	99.0 (3.90)	83.0 (3.27)	36.0 (1.42)	142.0 (5.59)	—	3/4-16 X 1.06dp (M22 x 2.5 - 27dp)	190.0 (7.48)
140 (5-1/2)	10-300 (0.39-12)	99.0 (3.90)	83.0 (3.27)	36.0 (1.42)	158.0 (6.22)	—	3/4-16 X 1.06dp (M22 x 2.5 - 27dp)	210.0 (8.27)
160 (6-1/4)	10-300 (0.39-12)	108.0 (4.25)	91.0 (3.58)	40.0 (1.58)	178.0 (7.01)	—	3/4-16 X 1.06dp (M24 x 3.0 - 27dp)	238.0 (9.37)



Universal Series  
Metric Compact Interchangeable

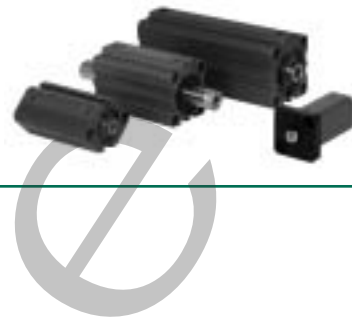

Double Acting, Single Rod continued

Ø32 - Ø160 mm Bores

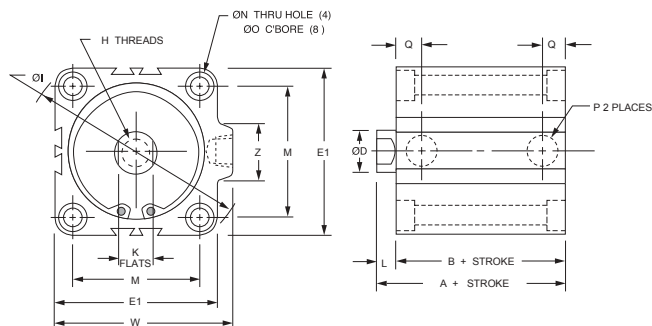

Port Size Offerings

- N - NPT ports, inch rod thread
- G - BSP parallel ports, metric rod thread
- P - BSPT taper ports, metric rod thread

NOTE: M5 x 0.8 port will accept #10-32 male thread fittings.

Rod End Male Thread

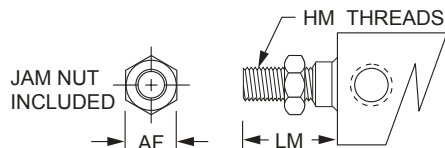

Tapped Hole Mounting

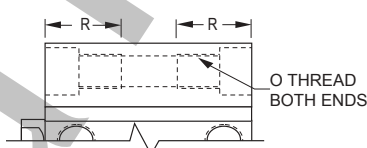

NOTE: Inch threads for 'N' port code.  
Metric threads for 'G' and 'P' port codes.  
Metric for foot, flange, and clevis mount.

BORE MM	AF (HEX) INCH (MM)	HM (THREADS) INCH (MM)	LM INCH (MM)
12	0.34 (8.0)	#8-32 X 0.31 lg (M5 x 0.8-9 lg)	0.45 (14.0)
16	0.34 (10.0)	#8-32 X 0.31 lg (M6 x 1.0-10 lg)	0.45 (15.5)
20	0.38 (13.0)	#10-32 X 0.31 lg (M8 x 1.25-12 lg)	0.49 (18.5)
25	0.43 (17.0)	1/4-28 X 0.37 lg (M10 x 1.25-15 lg)	0.57 (22.5)
32	0.50 (22.0)	5/16-24 X 0.50 lg (M14 x 1.5-20.5 lg)	0.78 (28.5)
40	0.56 (22.0)	3/8-24 X 0.63 lg (M14 x 1.5-20.5 lg)	0.91 (28.5)
50	0.75 (27.0)	1/2-20 X 0.77 lg (M18 x 1.5-26 lg)	1.08 (33.5)
63	0.75 (27.0)	1/2-20 X 0.77 lg (M18 x 1.5-26 lg)	1.08 (33.5)
80	0.93 (32.0)	5/8-18 X 1.0 lg (M22 x 1.5-32.5 lg)	1.40 (43.5)
100	1.13 (46.0)	3/4-16 X 1.12 lg (M26 x 1.5-32.5 lg)	1.59 (43.5)
125	1.13 (46.0)	3/4-16 X 1.12 lg (M30 x 1.5-42 lg)	1.75 (58.0)
140	1.13 (46.0)	3/4-16 X 1.12 lg (M30 x 1.5-42 lg)	1.75 (58.0)
160	1.13 (55.0)	3/4-16 X 1.12 lg (M36 x 1.5-47 lg)	1.79 (64.0)

BORE MM	O (THREADS) INCH (MM)	R INCH (MM)
12	#8-32 (M4 x 0.7)	0.43 (11.0)
16	#8-32 (M4 x 0.7)	0.43 (11.0)
20	1/4-20 (M6 x 1.0)	0.67 (17.0)
25	1/4-20 (M6 x 1.0)	0.67 (17.0)
32	1/4-20 (M6 x 1.0)	0.67 (17.0)
40	1/4-20 (M6 x 1.0)	0.75 (19.0)
50	5/16-18 (M8 x 1.25)	0.75 (19.0)
63	7/16-14 (M10 x 1.5)	0.87 (22.0)
80	1/2-13 (M12 x 1.75)	1.13 (29.0)
100	1/2-13 (M12 x 1.75)	1.13 (29.0)
125	- (M14 x 2.0)	- (45.0)
140	- (M14 x 2.0)	- (45.0)
160	- (M16 x 2.0)	- (50.0)

Dimensions measurements in millimeters and inches (in parenthesis)

BORE	K	L	M	ØN	ØO	*P	Q	W	Z
12 (1/2)	5.0 (0.20)	3.5 (0.14)	22.0 (0.87)	3.5 (0.14)	6.5 x 3.5dp (0.26 x 0.14 dp)	M5 x 0.8	7.0 (0.28)	-	-
16 (5/8)	6.0 (0.24)	3.5 (0.14)	28.0 (1.10)	3.5 (0.14)	6.5 x 3.5dp (0.26 x 0.14 dp)	M5 x 0.8	7.8 (0.31)	-	-
20 (3/4)	8.0 (0.31)	4.5 (0.18)	36.0 (1.42)	5.5 (0.22)	9.0 x 7.0dp (0.35 x 0.28 dp)	M5 x 0.8	8.1 (0.32)	-	-
25 (1)	10.0 (0.39)	5.0 (0.20)	40.0 (1.57)	5.5 (0.22)	9.0 x 7.0dp (0.35 x 0.28 dp)	M5 x 0.8	8.4 (0.33)	-	-
32 (1-1/4)	14.0 (0.55)	7.0 (0.28)	34.0 (1.34)	5.5 (0.22)	9.0 x 7.0dp (0.35 x 0.28 dp)	M5 x 0.8	8.7 (0.34)	49.3 (1.94)	21.4 (0.84)
	14.0 (0.55)	7.0 (0.28)	34.0 (1.34)	5.5 (0.22)	9.0 x 7.0dp (0.35 x 0.28 dp)	1/8*	8.7 (0.34)	49.3 (1.94)	21.4 (0.84)
40 (1-1/2)	14.0 (0.55)	7.0 (0.28)	40.0 (1.57)	5.5 (0.22)	9.0 x 7.0dp (0.35 x 0.28 dp)	1/8*	9.2 (0.36)	57.0 (2.24)	21.4 (0.84)
50 (2)	17.0 (0.67)	8.0 (0.31)	50.0 (1.97)	6.6 (0.26)	11.0 x 8.0dp (0.43 x 0.31 dp)	1/4*	10.5 (0.41)	70.6 (2.78)	26.5 (1.04)
63 (2-1/2)	17.0 (0.67)	8.0 (0.31)	60.0 (2.36)	9.0 (0.35)	14.0 x 10.5dp (0.55 x 0.41 dp)	1/4*	11.5 (0.45)	83.6 (3.29)	26.5 (1.04)
80 (3-1/4)	22.0 (0.87)	10.0 (0.39)	77.0 (3.03)	11.0 (0.43)	17.5 x 13.5dp (0.69 x 0.53 dp)	3/8*	14.0 (0.55)	104.0 (4.09)	30.0 (1.18)
100 (4)	27.0 (1.06)	12.0 (0.47)	94.0 (3.70)	11.0 (0.43)	17.5 x 13.5dp (0.69 x 0.53 dp)	3/8*	18.0 (0.71)	121.9 (4.80)	30.0 (1.18)
125 (4.9)	32.0 (1.26)	16.0 (0.63)	114.0 (4.49)	12.7 (0.50)	21.2 x 18.4dp (0.83 x 0.72 dp)	3/8*	24.5 (0.96)	153.0 (6.02)	39.0 (1.53)
140 (5-1/2)	32.0 (1.26)	16.0 (0.63)	128.0 (5.04)	12.7 (0.50)	21.2 x 18.4dp (0.83 x 0.72 dp)	3/8*	24.5 (0.96)	168.0 (6.61)	39.0 (1.53)
160 (6-1/4)	36.0 (1.42)	17.0 (0.67)	144.0 (5.67)	14.5 (0.57)	24.2 x 21.2dp (0.95 x 0.83 dp)	3/8*	27.5 (1.08)	188.0 (7.40)	39.0 (1.53)



Universal Series  
Metric Compact Interchangeable

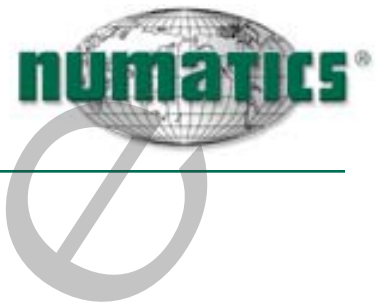

Double Acting, Double Rod

Ø12 - Ø16 mm Bores

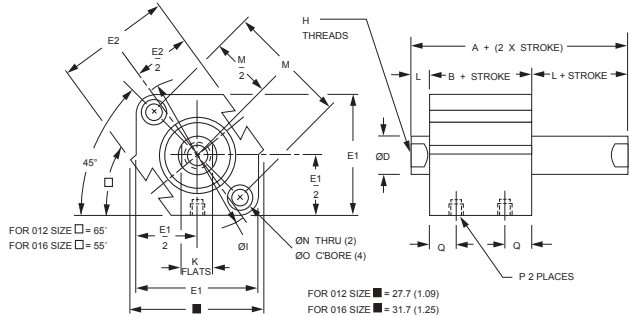

Ø20 - Ø25 mm Bores

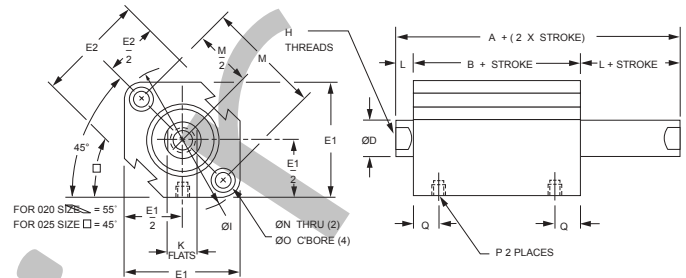

MODEL CODE "T"	
BORE	HOLE SIZE
12	N/A (N/A)
16	1.5 (0.06)
20	1.5 (0.06)
25	3.1 (0.13)
32	3.1 (0.13)
40	3.1 (0.13)
50	4.0 (0.16)
63	4.0 (0.16)
80	6.3 (0.25)
100	6.3 (0.25)
125	6.3 (0.25)
140	6.3 (0.25)
160	12.6 (0.50)

BORE MM	STROKE MM	LONG STROKE			EXTENDED STROKE			
		A	B	Q	STROKE MM	A	B	Q
12	-	-	-	-	50, 75, 100	40.8 (1.61)	33.8 (1.33)	8.9 (0.35)
		-	-	-	50, 75, 100	43.2 (1.70)	36.2 (1.42)	10.2 (0.40)
16	-	-	-	-	75, 100	50.6 (1.99)	41.6 (1.64)	12.1 (0.48)
		-	-	-	75, 100	57.5 (2.26)	47.5 (1.87)	12.7 (0.50)
20	-	75, 100	61.8 (2.43)	47.8 (1.88)	12.7 (0.50)	61.8 (2.43)	47.8 (1.88)	12.7 (0.50)
		75, 100	69.5 (2.74)	55.5 (2.19)	12.7 (0.50)	69.5 (2.74)	55.5 (2.19)	12.7 (0.50)
25	-	75, 100	75.3 (2.96)	59.3 (2.33)	13.2 (0.52)	75.3 (2.96)	59.3 (2.33)	13.2 (0.52)
		75, 100	80.6 (3.17)	64.6 (2.54)	18.5 (0.73)	80.6 (3.17)	64.6 (2.54)	18.5 (0.73)
32	-	75, 100	89.5 (3.52)	69.5 (2.74)	14.0 (0.55)	89.5 (3.52)	69.5 (2.74)	14.0 (0.55)
		75, 100	100.7 (3.96)	76.7 (3.02)	18.0 (0.71)	100.7 (3.96)	76.7 (3.02)	18.0 (0.71)
40	-	75, 100	89.5 (3.52)	69.5 (2.74)	14.0 (0.55)	89.5 (3.52)	69.5 (2.74)	14.0 (0.55)
		75, 100	100.7 (3.96)	76.7 (3.02)	18.0 (0.71)	100.7 (3.96)	76.7 (3.02)	18.0 (0.71)
50	-	75, 100	89.5 (3.52)	69.5 (2.74)	14.0 (0.55)	89.5 (3.52)	69.5 (2.74)	14.0 (0.55)
		75, 100	100.7 (3.96)	76.7 (3.02)	18.0 (0.71)	100.7 (3.96)	76.7 (3.02)	18.0 (0.71)
63	-	75, 100	89.5 (3.52)	69.5 (2.74)	14.0 (0.55)	89.5 (3.52)	69.5 (2.74)	14.0 (0.55)
		75, 100	100.7 (3.96)	76.7 (3.02)	18.0 (0.71)	100.7 (3.96)	76.7 (3.02)	18.0 (0.71)
80	-	75, 100	89.5 (3.52)	69.5 (2.74)	14.0 (0.55)	89.5 (3.52)	69.5 (2.74)	14.0 (0.55)
		75, 100	100.7 (3.96)	76.7 (3.02)	18.0 (0.71)	100.7 (3.96)	76.7 (3.02)	18.0 (0.71)
100	-	75, 100	89.5 (3.52)	69.5 (2.74)	14.0 (0.55)	89.5 (3.52)	69.5 (2.74)	14.0 (0.55)
		75, 100	100.7 (3.96)	76.7 (3.02)	18.0 (0.71)	100.7 (3.96)	76.7 (3.02)	18.0 (0.71)
125	-	75, 100	89.5 (3.52)	69.5 (2.74)	14.0 (0.55)	89.5 (3.52)	69.5 (2.74)	14.0 (0.55)
		75, 100	100.7 (3.96)	76.7 (3.02)	18.0 (0.71)	100.7 (3.96)	76.7 (3.02)	18.0 (0.71)
140	-	75, 100	89.5 (3.52)	69.5 (2.74)	14.0 (0.55)	89.5 (3.52)	69.5 (2.74)	14.0 (0.55)
		75, 100	100.7 (3.96)	76.7 (3.02)	18.0 (0.71)	100.7 (3.96)	76.7 (3.02)	18.0 (0.71)
160	-	75, 100	89.5 (3.52)	69.5 (2.74)	14.0 (0.55)	89.5 (3.52)	69.5 (2.74)	14.0 (0.55)
		75, 100	100.7 (3.96)	76.7 (3.02)	18.0 (0.71)	100.7 (3.96)	76.7 (3.02)	18.0 (0.71)

Dimensions measurements in millimeters and inches (in parenthesis)

BORE	STROKE	A	B	ØD	E1	E2	H (THREADS X dp MIN.)	Ø1
12 (1/2)	5-30 (0.20-1.18)	32.2 (1.27)	25.2 (0.99)	6.0 (0.24)	25.0 (0.98)	23.0 (0.90)	#8-32 x 0.21dp (M3 x 0.5 - 5dp)	31.5 (1.24)
16 (5/8)	5-30 (0.20-1.18)	33.0 (1.30)	26.0 (1.02)	8.0 (0.32)	29.0 (1.14)	27.2 (1.07)	#8-32 X 0.21dp (M4 x 0.7 - 5dp)	37.1 (1.46)
20 (3/4)	5-50 (0.20-2.0)	35.0 (1.38)	26.0 (1.02)	10.0 (0.39)	36.0 (1.42)	31.2 (1.23)	#10-32 X 0.28dp (M5 x 0.8 - 7dp)	47.0 (1.85)
25 (1)	5-50 (0.20-2.0)	39.0 (1.54)	29.0 (1.14)	12.0 (0.47)	40.0 (1.57)	36.9 (1.45)	1/4-28 X 0.39dp (M6 x 1.0 - 10dp)	51.3 (2.02)
32 (1-1/4)	5 only (0.20)	44.5 (1.75)	30.5 (1.20)	16.0 (0.63)	44.5 (1.75)	-	5/16-24 X 0.50dp (M8 x 1.25 - 12dp)	58.9 (2.32)
	10-50 (0.39-2.0)	44.5 (1.75)	30.5 (1.20)	16.0 (0.63)	44.5 (1.75)	-	5/16-24 X 0.50dp (M8 x 1.25 - 12dp)	58.9 (2.32)
40 (1-1/2)	5-50 (0.20-2.0)	54.0 (2.13)	40.0 (1.57)	16.0 (0.63)	52.0 (2.05)	-	3/8-24 X 0.50dp (M8 x 1.25 - 12dp)	69.0 (2.72)
50 (2)	10-50 (0.39-2.0)	56.5 (2.22)	40.5 (1.59)	20.0 (0.79)	63.7 (2.51)	-	1/2-20 X 0.50dp (M10 x 1.5 - 12dp)	84.9 (3.34)
63 (2-1/2)	10-50 (0.39-2.0)	58.0 (2.28)	42.0 (1.65)	20.0 (0.79)	76.7 (3.02)	-	1/2-20 X 0.50dp (M10 x 1.5 - 12dp)	101.8 (4.01)
80 (3-1/4)	10-50 (0.39-2.0)	71.0 (2.80)	51.0 (2.01)	25.0 (0.98)	97.8 (3.85)	-	5/8-18 X 0.88dp (M16 x 2.0 - 22dp)	129.8 (5.11)
100 (4)	10-50 (0.39-2.0)	84.5 (3.33)	60.5 (2.38)	30.0 (1.18)	115.3 (4.54)	-	3/4-16 X 0.88dp (M20 x 2.5 - 22dp)	153.9 (6.06)
125 (4.9)	10-300 (0.39-12)	115.0 (4.53)	83.0 (3.27)	36.0 (1.42)	142.0 (5.59)	-	3/4-16 X 1.06dp (M22 x 2.5 - 27dp)	190.0 (7.48)
140 (5-1/2)	10-300 (0.39-12)	115.0 (4.53)	83.0 (3.27)	36.0 (1.42)	158.0 (6.22)	-	3/4-16 X 1.06dp (M22 x 2.5 - 27dp)	210.0 (8.27)
160 (6-1/4)	10-300 (0.39-12)	125.0 (4.92)	91.0 (3.58)	40.0 (1.58)	178.0 (7.01)	-	3/4-16 X 1.06dp (M24 x 3.0 - 27dp)	238.0 (9.37)

NOTE: See page 5 for complete stroke availability.





Universal Series  
Metric Compact Interchangeable

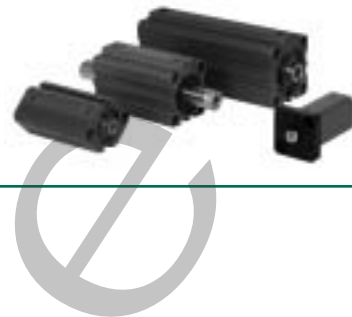

Double Acting, Double Rod continued  
Ø32 - Ø160 mm Bores

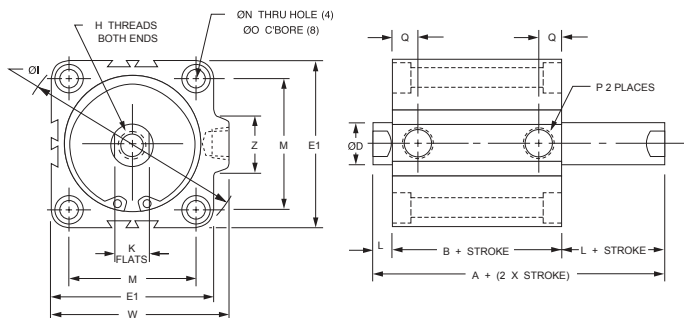

Port Size Offerings

- N - NPT ports, inch rod thread
- G - BSP parallel ports, metric rod thread
- P - BSPT taper ports, metric rod thread

NOTE: M5 x 0.8 port will accept #10-32 male thread fittings.

Rod End Male Thread

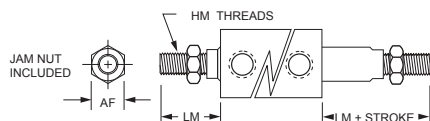

Tapped Hole Mounting

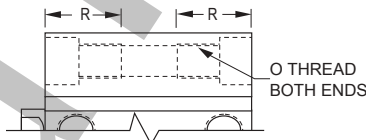

NOTE: Inch threads for 'N' port code.  
Metric threads for 'G' and 'P' port codes.  
Metric for foot, flange, and clevis mount.

BORE MM	AF (HEX) INCH (MM)	HM (THREADS) INCH (MM)	LM INCH (MM)
12	0.34 (8.0)	#8-32 X 0.31 lg (M5 x 0.8-9 lg)	0.45 (14.0)
16	0.34 (10.0)	#8-32 X 0.31 lg (M6 x 1.0-10 lg)	0.45 (15.5)
20	0.38 (13.0)	#10-32 X 0.31 lg (M8 x 1.25-12 lg)	0.49 (18.5)
25	0.43 (17.0)	1/4-28 X 0.37 lg (M10 x 1.25-15 lg)	0.57 (22.5)
32	0.50 (22.0)	5/16-24 X 0.50 lg (M14 x 1.5-20.5 lg)	0.78 (28.5)
40	0.56 (22.0)	3/8-24 X 0.63 lg (M14 x 1.5-20.5 lg)	0.91 (28.5)
50	0.75 (27.0)	1/2-20 X 0.77 lg (M18 x 1.5-26 lg)	1.08 (33.5)
63	0.75 (27.0)	1/2-20 X 0.77 lg (M18 x 1.5-26 lg)	1.08 (33.5)
80	0.93 (32.0)	5/8-18 X 1.0 lg (M22 x 1.5-32.5 lg)	1.40 (43.5)
100	1.13 (46.0)	3/4-16 X 1.12 lg (M26 x 1.5-32.5 lg)	1.59 (43.5)
125	1.13 (46.0)	3/4-16 X 1.12 lg (M30 x 1.5-42 lg)	1.75 (58.0)
140	1.13 (46.0)	3/4-16 X 1.12 lg (M30 x 1.5-42 lg)	1.75 (58.0)
160	1.13 (55.0)	3/4-16 X 1.12 lg (M36 x 1.5-47 lg)	1.79 (64.0)

BORE MM	O (THREADS) INCH (MM)	R INCH (MM)
12	#8-32 (M4 x 0.7)	0.43 (11.0)
16	#8-32 (M4 x 0.7)	0.43 (11.0)
20	1/4-20 (M6 x 1.0)	0.67 (17.0)
25	1/4-20 (M6 x 1.0)	0.67 (17.0)
32	1/4-20 (M6 x 1.0)	0.67 (17.0)
40	1/4-20 (M6 x 1.0)	0.75 (19.0)
50	5/16-18 (M8 x 1.25)	0.75 (19.0)
63	7/16-14 (M10 x 1.5)	0.87 (22.0)
80	1/2-13 (M12 x 1.75)	1.13 (29.0)
100	1/2-13 (M12 x 1.75)	1.13 (29.0)
125	- (M14 x 2.0)	- (45.0)
140	- (M14 x 2.0)	- (45.0)
160	- (M16 x 2.0)	- (50.0)

Dimensions measurements in millimeters and inches (in parenthesis)

BORE	K	L	M	ØN	ØO	*P	Q	W	Z
12 (1/2)	5.0 (0.20)	3.5 (0.14)	22.0 (0.87)	3.5 (0.14)	6.5 x 3.5dp (0.26 x 0.14 dp)	M5 x 0.8	7.0 (0.28)	-	-
16 (5/8)	6.0 (0.24)	3.5 (0.14)	28.0 (1.10)	3.5 (0.14)	6.5 x 3.5dp (0.26 x 0.14 dp)	M5 x 0.8	7.8 (0.31)	-	-
20 (3/4)	8.0 (0.31)	4.5 (0.18)	36.0 (1.42)	5.5 (0.22)	9.0 x 7.0dp (0.35 x 0.28 dp)	M5 x 0.8	8.1 (0.32)	-	-
25 (1)	10.0 (0.39)	5.0 (0.20)	40.0 (1.57)	5.5 (0.22)	9.0 x 7.0dp (0.35 x 0.28 dp)	M5 x 0.8	8.4 (0.33)	-	-
32 (1-1/4)	14.0 (0.55)	7.0 (0.28)	34.0 (1.34)	5.5 (0.22)	9.0 x 7.0dp (0.35 x 0.28 dp)	M5 x 0.8	8.7 (0.34)	49.3 (1.94)	21.4 (0.84)
	14.0 (0.55)	7.0 (0.28)	34.0 (1.34)	5.5 (0.22)	9.0 x 7.0dp (0.35 x 0.28 dp)	1/8*	8.7 (0.34)	49.3 (1.94)	21.4 (0.84)
40 (1-1/2)	14.0 (0.55)	7.0 (0.28)	40.0 (1.57)	5.5 (0.22)	9.0 x 7.0dp (0.35 x 0.28 dp)	1/8*	9.2 (0.36)	57.0 (2.24)	21.4 (0.84)
50 (2)	17.0 (0.67)	8.0 (0.31)	50.0 (1.97)	6.6 (0.26)	11.0 x 8.0dp (0.43 x 0.31 dp)	1/4*	10.5 (0.41)	70.6 (2.78)	26.5 (1.04)
63 (2-1/2)	17.0 (0.67)	8.0 (0.31)	60.0 (2.36)	9.0 (0.35)	14.0 x 10.5dp (0.55 x 0.41 dp)	1/4*	11.5 (0.45)	83.6 (3.29)	26.5 (1.04)
80 (3-1/4)	22.0 (0.87)	10.0 (0.39)	77.0 (3.03)	11.0 (0.43)	17.5 x 13.5dp (0.69 x 0.53 dp)	3/8*	14.0 (0.55)	104.0 (4.09)	30.0 (1.18)
100 (4)	27.0 (1.06)	12.0 (0.47)	94.0 (3.70)	11.0 (0.43)	17.5 x 13.5dp (0.69 x 0.53 dp)	3/8*	18.0 (0.71)	121.9 (4.80)	30.0 (1.18)
125 (4.9)	32.0 (1.26)	16.0 (0.63)	114.0 (4.49)	12.7 (0.50)	21.2 x 18.4dp (0.83 x 0.72 dp)	3/8*	24.5 (0.96)	153.0 (6.02)	39.0 (1.53)
140 (5-1/2)	32.0 (1.26)	16.0 (0.63)	128.0 (5.04)	12.7 (0.50)	21.2 x 18.4dp (0.83 x 0.72 dp)	3/8*	24.5 (0.96)	168.0 (6.61)	39.0 (1.53)
160 (6-1/4)	36.0 (1.42)	17.0 (0.67)	144.0 (5.67)	14.5 (0.57)	24.2 x 21.2dp (0.95 x 0.83 dp)	3/8*	27.5 (1.08)	188.0 (7.40)	39.0 (1.53)



Universal Series  
Metric Compact Interchangeable



Double Acting, Non-Rotating Piston Rod

Ø12 - Ø16 mm Bores

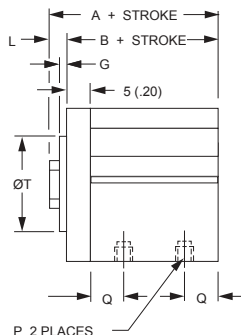
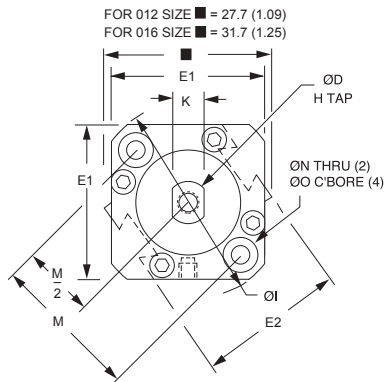

Ø20 - Ø25 mm Bores

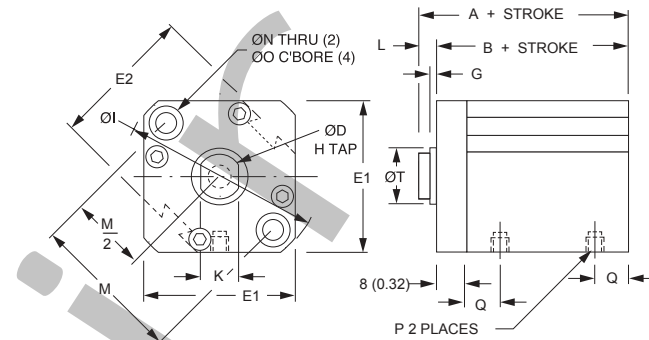

Rod flats (Dim. K) nominally in-line with ports.

Port Size Offerings

- N - NPT ports, inch rod thread
- G - BSP parallel ports, metric rod thread
- P - BSPT taper ports, metric rod thread

NOTE: M5 x 0.8 port with accept #10-32 male thread fittings.

**WARNING:** This cylinder has a non-rotating rod. To prevent internal damage hold rod by flats **ONLY** WHEN FULLY RETRACTED while installing or removing attachments. **DO NOT** scratch or dent shaft.

BORE MM	STROKE MM	A	B	Q	STROKE MM	A	B	Q
12	-	-	-	-	50, 75, 100	42.3 (1.67)	38.8 (1.53)	8.9 (0.35)
	-	-	-	-	50, 75, 100	44.7 (1.76)	41.2 (1.62)	10.2 (0.40)
16	-	-	-	-	75, 100	54.1 (2.13)	49.6 (1.95)	12.1 (0.48)
	-	-	-	-	75, 100	60.5 (2.38)	55.5 (2.19)	12.7 (0.50)
20	75, 100	49.0 (1.93)	42.0 (1.65)	8.7 (0.34)	125, 150	63.8 (2.51)	56.8 (2.24)	12.7 (0.50)
	75, 100	46.5 (1.83)	39.5 (1.56)	9.2 (0.36)	125, 150	62.5 (2.46)	55.5 (2.19)	12.7 (0.50)
25	75, 100	48.5 (1.91)	40.5 (1.59)	10.5 (0.41)	125, 150	67.3 (2.65)	59.3 (2.33)	13.2 (0.52)
	75, 100	54.0 (2.13)	46.0 (1.81)	11.5 (0.45)	125, 150	72.6 (2.86)	64.6 (2.54)	18.5 (0.73)
32	75, 100	63.5 (2.50)	53.5 (2.11)	14.0 (0.55)	125, 150	79.5 (3.13)	69.5 (2.74)	14.0 (0.55)
	75, 100	75.0 (2.95)	63.0 (2.48)	18.0 (0.71)	125, 150	88.7 (3.49)	76.7 (3.02)	18.0 (0.71)

BORE SIZE	12	16	20	25	32	40	50	63	80	100
NON-ROTATING ROD ACCURACY	±2°	±1°	±1°	±1°	±0.8°	±0.8°	±0.8°	±0.8°	±0.8°	±0.8°

NOTE: See page 5 for complete stroke availability.

Dimensions measurements in millimeters and inches (in parenthesis)

BORE	STROKE	A	B	ØD	E1	E2	H (THREADS X dp MIN.)	ØI
12 (1/2)	5-30 (0.20-1.18)	25.5 (1.00)	22.0 (0.87)	6.0 (0.24)	25.0 (0.98)	23.0 (0.90)	#8-32 x 0.21dp (M3 x 0.5 - 5dp)	31.5 (1.24)
16 (5/8)	5-30 (0.20-1.18)	27.0 (1.06)	23.5 (0.93)	8.0 (0.32)	29.0 (1.14)	27.2 (1.07)	#8-32 X 0.21dp (M4 x 0.7 - 5dp)	37.1 (1.46)
20 (3/4)	5-50 (0.20-2.0)	32.0 (1.26)	27.5 (1.08)	10.0 (0.39)	36.0 (1.42)	31.2 (1.23)	#10-32 X 0.28dp (M5 x 0.8 - 7dp)	47.0 (1.85)
25 (1)	5-50 (0.20-2.0)	35.5 (1.40)	30.5 (1.20)	12.0 (0.47)	40.0 (1.57)	36.9 (1.45)	1/4-28 X 0.39dp (M6 x 1.0 - 10dp)	51.3 (2.02)
32 (1-1/4)	5 only (0.20)	39.0 (1.54)	32.0 (1.26)	16.0 (0.63)	44.5 (1.75)	-	5/16-24 X 0.50dp (M8 x 1.25 - 12dp)	58.9 (2.32)
	10-50 (0.39-2.0)	39.0 (1.54)	32.0 (1.26)	16.0 (0.63)	44.5 (1.75)	-	5/16-24 X 0.50dp (M8 x 1.25 - 12dp)	58.9 (2.32)
40 (1-1/2)	5-50 (0.20-2.0)	36.5 (1.44)	29.5 (1.16)	16.0 (0.63)	52.0 (2.05)	-	3/8-24 X 0.50dp (M8 x 1.25 - 12dp)	69.0 (2.72)
50 (2)	10-50 (0.39-2.0)	38.5 (1.52)	30.5 (1.20)	20.0 (0.79)	63.7 (2.51)	-	1/2-20 X 0.50dp (M10 x 1.5 - 12dp)	84.9 (3.34)
63 (2-1/2)	10-50 (0.39-2.0)	44.0 (1.73)	36.0 (1.42)	20.0 (0.79)	76.7 (3.02)	-	1/2-20 X 0.50dp (M10 x 1.5 - 12dp)	101.8 (4.01)
80 (3-1/4)	10-50 (0.39-2.0)	53.5 (2.11)	43.5 (1.71)	25.0 (0.98)	97.8 (3.85)	-	5/8-18 X 0.88dp (M16 x 2.0 - 22dp)	129.8 (5.11)
100 (4)	10-50 (0.39-2.0)	65.0 (2.56)	53.0 (2.09)	30.0 (1.18)	115.3 (4.54)	-	3/4-16 X 0.88dp (M20 x 2.5 - 22dp)	153.9 (6.06)



Universal Series  
Metric Compact Interchangeable



Double Acting, Non-Rotating Piston Rod continued

Ø32 mm Bores

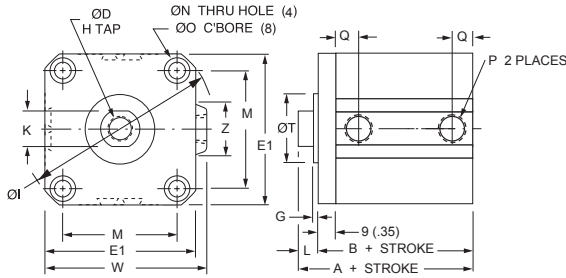

Ø40 - Ø100 mm Bores

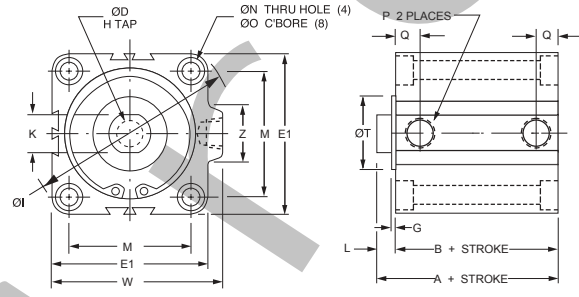

Rod End Male Thread

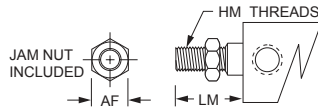

Rod flats (Dim. K) nominally in-line with ports.

Tapped Hole Mounting

NOTE: Inch threads for 'N' port code.  
Metric threads for 'G' and 'P' port codes.  
Metric for foot, flange, and clevis mount.

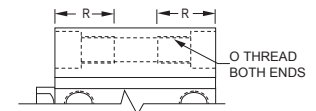

BORE MM	AF (HEX) INCH (MM)	HM (THREADS) INCH (MM)	LM INCH (MM)
12	0.34 (8.0)	#8-32 X 0.31 lg (M5 x 0.8-9 lg)	0.45 (14.0)
16	0.34 (10.0)	#8-32 X 0.31 lg (M6 x 1.0-10 lg)	0.45 (15.5)
20	0.38 (13.0)	#10-32 X 0.31 lg (M8 x 1.25-12 lg)	0.49 (18.5)
25	0.43 (17.0)	1/4-28 X 0.37 lg (M10 x 1.25-15 lg)	0.57 (22.5)
32	0.50 (22.0)	5/16-24 X 0.50 lg (M14 x 1.5-20.5 lg)	0.78 (28.5)
40	0.56 (22.0)	3/8-24 X 0.63 lg (M14 x 1.5-20.5 lg)	0.91 (28.5)
50	0.75 (27.0)	1/2-20 X 0.77 lg (M18 x 1.5-26 lg)	1.08 (33.5)
63	0.75 (27.0)	1/2-20 X 0.77 lg (M18 x 1.5-26 lg)	1.08 (33.5)
80	0.93 (32.0)	5/8-18 X 1.0 lg (M22 x 1.5-32.5 lg)	1.40 (43.5)
100	1.13 (46.0)	3/4-16 X 1.12 lg (M26 x 1.5-32.5 lg)	1.59 (43.5)

BORE MM	O (THREADS) INCH (MM)	PLACES FRONT	RF INCH (MM)	PLACES REAR	RR INCH (MM)
12	#8-32 (M4 x 0.7)	2	0.63 (16.0)	2	0.43 (11.0)
16	#8-32 (M4 x 0.7)	2	0.63 (16.0)	2	0.43 (11.0)
20	1/4-20 (M6 x 1.0)	2	0.98 (25.0)	2	0.67 (17.0)
25	1/4-20 (M6 x 1.0)	2	0.98 (25.0)	2	0.67 (17.0)
32	1/4-20 (M6 x 1.0)	2	1.02 (26.0)	4	0.67 (17.0)
40	1/4-20 (M6 x 1.0)	4	0.75 (19.0)	4	0.75 (19.0)
50	5/16-18 (M8 x 1.25)	4	0.75 (19.0)	4	0.75 (19.0)
63	7/16-14 (M10 x 1.5)	4	0.87 (22.0)	4	0.87 (22.0)
80	1/2-13 (M12 x 1.75)	4	1.13 (29.0)	4	1.13 (29.0)
100	1/2-13 (M12 x 1.75)	4	1.13 (29.0)	4	1.13 (29.0)

Dimensions measurements in millimeters and inches (in parenthesis)

BORE	K	L	M	ØN	ØO	*P	Q	W	Z
12 (1/2)	5.2 (0.20)	3.5 (0.14)	22.0 (0.87)	3.5 (0.14)	6.5 x 3.5dp (0.26 x 0.14 dp)	M5 x 0.8	7.0 (0.28)	-	-
16 (5/8)	6.0 (0.24)	3.5 (0.14)	28.0 (1.10)	3.5 (0.14)	6.5 x 3.5dp (0.26 x 0.14 dp)	M5 x 0.8	7.8 (0.31)	-	-
20 (3/4)	8.0 (0.31)	4.5 (0.18)	36.0 (1.42)	5.5 (0.22)	9.0 x 7.0dp (0.35 x 0.28 dp)	M5 x 0.8	8.1 (0.32)	-	-
25 (1)	10.0 (0.39)	5.0 (0.20)	40.0 (1.57)	5.5 (0.22)	9.0 x 7.0dp (0.35 x 0.28 dp)	M5 x 0.8	8.4 (0.33)	-	-
32 (1-1/4)	14.0 (0.55)	7.0 (0.28)	34.0 (1.34)	5.5 (0.22)	9.0 x 7.0dp (0.35 x 0.28 dp)	M5 x 0.8	8.7 (0.34)	49.3 (1.94)	21.4 (0.84)
	14.0 (0.55)	7.0 (0.28)	34.0 (1.34)	5.5 (0.22)	9.0 x 7.0dp (0.35 x 0.28 dp)	1/8*	8.7 (0.34)	49.3 (1.94)	21.4 (0.84)
40 (1-1/2)	14.0 (0.55)	7.0 (0.28)	40.0 (1.57)	5.5 (0.22)	9.0 x 7.0dp (0.35 x 0.28 dp)	1/8*	9.2 (0.36)	57.0 (2.24)	21.4 (0.84)
50 (2)	18.0 (0.71)	8.0 (0.31)	50.0 (1.97)	6.6 (0.26)	11.0 x 8.0dp (0.43 x 0.31 dp)	1/4*	10.5 (0.41)	70.6 (2.78)	26.5 (1.04)
63 (2-1/2)	18.0 (0.71)	8.0 (0.31)	60.0 (2.36)	9.0 (0.35)	14.0 x 10.5dp (0.55 x 0.41 dp)	1/4*	11.5 (0.45)	83.6 (3.29)	26.5 (1.04)
80 (3-1/4)	22.0 (0.87)	10.0 (0.39)	77.0 (3.03)	11.0 (0.43)	17.5 x 13.5dp (0.69 x 0.53 dp)	3/8*	14.0 (0.55)	104.0 (4.09)	30.0 (1.18)
100 (4)	27.0 (1.06)	12.0 (0.47)	94.0 (3.70)	11.0 (0.43)	17.5 x 13.5dp (0.69 x 0.53 dp)	3/8*	18.0 (0.71)	121.9 (4.80)	30.0 (1.18)

BORE	ØT	G
12 (1/2)	15 +0/-0.043 (0.591 +0/-0.002)	1.5 (0.06)
16 (5/8)	20 +0/-0.052 (0.787 +0/-0.002)	1.5 (0.06)
20 (3/4)	13 +0/-0.043 (0.512 +0/-0.002)	2.0 (0.08)
25 (1)	15 +0/-0.043 (0.591 +0/-0.002)	2.0 (0.08)
32 (1-1/4)	21 +0/-0.062 (0.827 +0/-0.002)	2.0 (0.08)
40 (1-1/2)	28 +0/-0.062 (1.102 +0/-0.002)	2.0 (0.08)
50 (2)	35 +0/-0.062 (1.378 +0/-0.002)	2.0 (0.08)
63 (2-1/2)	35 +0/-0.062 (1.378 +0/-0.002)	2.0 (0.08)
80 (3-1/4)	43 +0/-0.062 (1.693 +0/-0.002)	2.0 (0.08)
100 (4)	59 +0/-0.074 (2.323 +0/-0.003)	2.0 (0.08)

Universal Series  
Metric Compact Interchangeable

Double Acting, Double Rod, Non-Rotating Piston Rod

Ø12 - Ø16 mm Bores

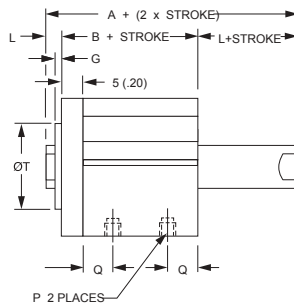
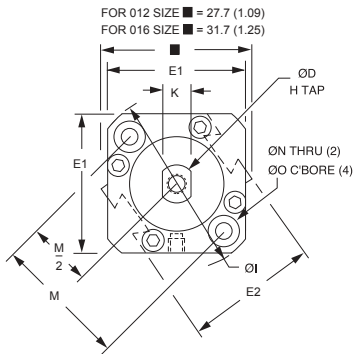

Ø20 - Ø25 mm Bores

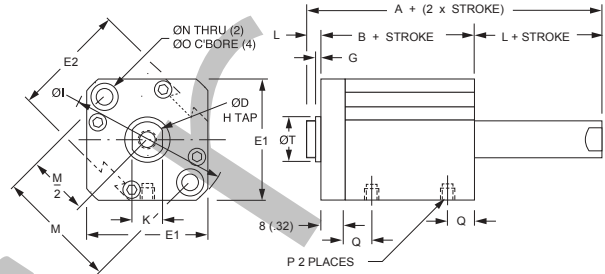

Rod flats (Dim. K) nominally in-line with ports.

Port Size Offerings

N - NPT ports, inch rod thread

G - BSP parallel ports, metric rod thread

P - BSPT taper ports, metric rod thread

NOTE: M5 x 0.8 port will accept #10-32 male thread fittings.

**WARNING:** This cylinder has a non-rotating rod. To prevent internal damage hold rod by flats **ONLY** WHEN FULLY RETRACTED while installing or removing attachments. **DO NOT** scratch or dent shaft.

BORE SIZE	12	16	20	25	32	40	50	63	80	100
-----------	----	----	----	----	----	----	----	----	----	-----

NON-ROTATING ROD ACCURACY	±2°	±1°	±1°	±1°	±0.8°	±0.8°	±0.8°	±0.8°	±0.8°	±0.8°
---------------------------	-----	-----	-----	-----	-------	-------	-------	-------	-------	-------

MODEL CODE "M"	
BORE	HOLE SIZE
12	N/A (N/A)
16	1.5 (0.06)
20	1.5 (0.06)
25	3.1 (0.13)
32	3.1 (0.13)
40	3.1 (0.13)
50	4.0 (0.16)
63	4.0 (0.16)
80	6.3 (0.25)
100	6.3 (0.25)

BORE MM	STROKE MM	LONG STROKE			EXTENDED STROKE			
		A	B	Q	STROKE MM	A	B	Q
12	-	-	-	-	50, 75, 100	45.8 (1.80)	38.8 (1.53)	8.9 (0.35)
16	-	-	-	-	50, 75, 100	48.2 (1.90)	41.2 (1.62)	10.2 (0.40)
20	-	-	-	-	75, 100	58.6 (2.31)	49.6 (1.95)	12.1 (0.48)
25	-	-	-	-	75, 100	65.5 (2.58)	55.5 (2.19)	12.7 (0.50)
32	75, 100	70.8 (2.79)	56.8 (2.24)	12.7 (0.50)	125, 150	70.8 (2.79)	56.8 (2.24)	12.7 (0.50)
40	75, 100	69.5 (2.74)	55.5 (2.19)	12.7 (0.50)	125, 150	69.5 (2.74)	55.5 (2.19)	12.7 (0.50)
50	75, 100	75.3 (2.96)	59.3 (2.33)	13.2 (0.52)	125, 150	75.3 (2.96)	59.3 (2.33)	13.2 (0.52)
63	75, 100	80.6 (3.17)	64.6 (2.54)	18.5 (0.73)	125, 150	80.6 (3.17)	64.6 (2.54)	18.5 (0.73)
80	75, 100	89.5 (3.52)	69.5 (2.74)	14.0 (0.55)	125, 150	89.5 (3.52)	69.5 (2.74)	14.0 (0.55)
100	75, 100	100.7 (3.96)	76.7 (3.02)	18.0 (0.71)	125, 150	100.7 (3.96)	76.7 (3.02)	18.0 (0.71)

NOTE: See page 5 for complete stroke availability.

Dimensions measurements in millimeters and inches (in parenthesis)

BORE	STROKE	A	B	ØD	E1	E2	H (THREADS X dp MIN.)	ØI
12 (1/2)	5-30 (0.20-1.18)	37.2 (1.46)	30.2 (1.19)	6.0 (0.24)	25.0 (0.98)	23.0 (0.90)	#8-32 x 0.21dp (M3 x 0.5 - 5dp)	31.5 (1.24)
16 (5/8)	5-30 (0.20-1.18)	38.0 (1.50)	31.0 (1.22)	8.0 (0.32)	29.0 (1.14)	27.2 (1.07)	#8-32 X 0.21dp (M4 x 0.7 - 5dp)	37.1 (1.46)
20 (3/4)	5-50 (0.20-2.0)	43.0 (1.69)	34.0 (1.34)	10.0 (0.39)	36.0 (1.42)	31.2 (1.23)	#10-32 X 0.28dp (M5 x 0.8 - 7dp)	47.0 (1.85)
25 (1)	5-50 (0.20-2.0)	47.0 (1.85)	37.0 (1.46)	12.0 (0.47)	40.0 (1.57)	36.9 (1.45)	1/4-28 X 0.39dp (M6 x 1.0 - 10dp)	51.3 (2.02)
32 (1-1/4)	5 only (0.20) 10-50 (0.39-2.0)	53.5 (2.11)	39.5 (1.56)	16.0 (0.63)	44.5 (1.75)	-	5/16-24 X 0.50dp (M8 x 1.25 - 12dp)	58.9 (2.32)
40 (1-1/2)	5-50 (0.20-2.0)	54.0 (2.13)	40.0 (1.57)	16.0 (0.63)	52.0 (2.05)	-	3/8-24 X 0.50dp (M8 x 1.25 - 12dp)	69.0 (2.72)
50 (2)	10-50 (0.39-2.0)	56.5 (2.22)	40.5 (1.59)	20.0 (0.79)	63.7 (2.51)	-	1/2-20 X 0.50dp (M10 x 1.5 - 12dp)	84.9 (3.34)
63 (2-1/2)	10-50 (0.39-2.0)	58.0 (2.28)	42.0 (1.65)	20.0 (0.79)	76.7 (3.02)	-	1/2-20 X 0.50dp (M10 x 1.5 - 12dp)	101.8 (4.01)
80 (3-1/4)	10-50 (0.39-2.0)	71.0 (2.80)	51.0 (2.01)	25.0 (0.98)	97.8 (3.85)	-	5/8-18 X 0.88dp (M16 x 2.0 - 22dp)	129.8 (5.11)



Universal Series  
Metric Compact Interchangeable



Double Acting, Double Rod, Non-Rotating Piston Rod continued

Ø32 mm Bores

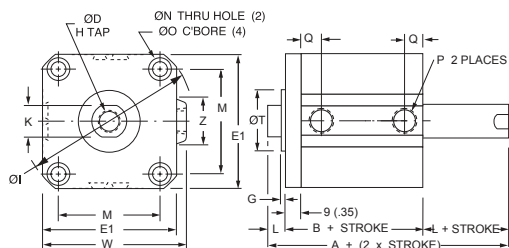

Ø40 - Ø100 mm Bores

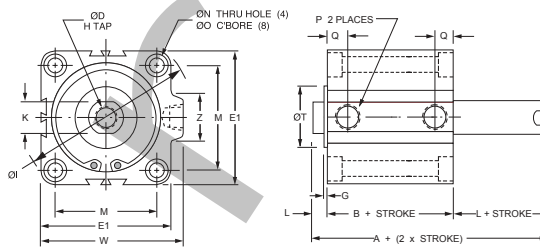

Rod End Male Thread

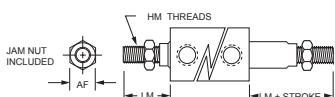

Tapped Hole Mounting

NOTE: Inch threads for 'N' port code.  
Metric threads for 'G' and 'P' port codes.  
Metric for foot, flange, and clevis mount.

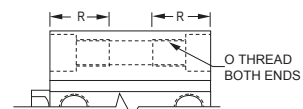

BORE MM	AF (HEX) INCH (MM)	HM (THREADS) INCH (MM)	LM INCH (MM)
12	0.34 (8.0)	#8-32 X 0.31 lg (M5 x 0.8-9 lg)	0.45 (14.0)
16	0.34 (10.0)	#8-32 X 0.31 lg (M6 x 1.0-10 lg)	0.45 (15.5)
20	0.38 (13.0)	#10-32 X 0.31 lg (M8 x 1.25-12 lg)	0.49 (18.5)
25	0.43 (17.0)	1/4-28 X 0.37 lg (M10 x 1.25-15 lg)	0.57 (22.5)
32	0.50 (22.0)	5/16-24 X 0.50 lg (M14 x 1.5-20.5 lg)	0.78 (28.5)
40	0.56 (22.0)	3/8-24 X 0.63 lg (M14 x 1.5-20.5 lg)	0.91 (28.5)
50	0.75 (27.0)	1/2-20 X 0.77 lg (M18 x 1.5-26 lg)	1.08 (33.5)
63	0.75 (27.0)	1/2-20 X 0.77 lg (M18 x 1.5-26 lg)	1.08 (33.5)
80	0.93 (32.0)	5/8-18 X 1.0 lg (M22 x 1.5-32.5 lg)	1.40 (43.5)
100	1.13 (46.0)	3/4-16 X 1.12 lg (M26 x 1.5-32.5 lg)	1.59 (43.5)

BORE MM	O (THREADS) INCH (MM)	PLACES FRONT	RF INCH (MM)	PLACES REAR	RR INCH (MM)
12	#8-32 (M4 x 0.7)	2	0.63 (16.0)	2	0.43 (11.0)
16	#8-32 (M4 x 0.7)	2	0.63 (16.0)	2	0.43 (11.0)
20	1/4-20 (M6 x 1.0)	2	0.98 (25.0)	2	0.67 (17.0)
25	1/4-20 (M6 x 1.0)	2	0.98 (25.0)	2	0.67 (17.0)
32	1/4-20 (M6 x 1.0)	2	1.02 (26.0)	4	0.67 (17.0)
40	1/4-20 (M6 x 1.0)	4	0.75 (19.0)	4	0.75 (19.0)
50	5/16-18 (M8 x 1.25)	4	0.75 (19.0)	4	0.75 (19.0)
63	7/16-14 (M10 x 1.5)	4	0.87 (22.0)	4	0.87 (22.0)
80	1/2-13 (M12 x 1.75)	4	1.13 (29.0)	4	1.13 (29.0)
100	1/2-13 (M12 x 1.75)	4	1.13 (29.0)	4	1.13 (29.0)

Dimensions measurements in millimeters and inches (in parenthesis)

BORE	K	L	M	ØN	ØO	*P	Q	W	Z
12 (1/2)	5.2 (0.20)	3.5 (0.14)	22.0 (0.87)	3.5 (0.14)	6.5 x 3.5dp (0.26 x 0.14 dp)	M5 x 0.8	7.0 (0.28)	-	-
16 (5/8)	6.0 (0.24)	3.5 (0.14)	28.0 (1.10)	3.5 (0.14)	6.5 x 3.5dp (0.26 x 0.14 dp)	M5 x 0.8	7.8 (0.31)	-	-
20 (3/4)	8.0 (0.31)	4.5 (0.18)	36.0 (1.42)	5.5 (0.22)	9.0 x 7.0dp (0.35 x 0.28 dp)	M5 x 0.8	8.1 (0.32)	-	-
25 (1)	10.0 (0.39)	5.0 (0.20)	40.0 (1.57)	5.5 (0.22)	9.0 x 7.0dp (0.35 x 0.28 dp)	M5 x 0.8	8.4 (0.33)	-	-
32 (1-1/4)	14.0 (0.55)	7.0 (0.28)	34.0 (1.34)	5.5 (0.22)	9.0 x 7.0dp (0.35 x 0.28 dp)	M5 x 0.8	8.7 (0.34)	49.3 (1.94)	21.4 (0.84)
	14.0 (0.55)	7.0 (0.28)	34.0 (1.34)	5.5 (0.22)	9.0 x 7.0dp (0.35 x 0.28 dp)	1/8*	8.7 (0.34)	49.3 (1.94)	21.4 (0.84)
40 (1-1/2)	14.0 (0.55)	7.0 (0.28)	40.0 (1.57)	5.5 (0.22)	9.0 x 7.0dp (0.35 x 0.28 dp)	1/8*	9.2 (0.36)	57.0 (2.24)	21.4 (0.84)
50 (2)	18.0 (0.71)	8.0 (0.31)	50.0 (1.97)	6.6 (0.26)	11.0 x 8.0dp (0.43 x 0.31 dp)	1/4*	10.5 (0.41)	70.6 (2.78)	26.5 (1.04)
63 (2-1/2)	18.0 (0.71)	8.0 (0.31)	60.0 (2.36)	9.0 (0.35)	14.0 x 10.5dp (0.55 x 0.41 dp)	1/4*	11.5 (0.45)	83.6 (3.29)	26.5 (1.04)
80 (3-1/4)	22.0 (0.87)	10.0 (0.39)	77.0 (3.03)	11.0 (0.43)	17.5 x 13.5dp (0.69 x 0.53 dp)	3/8*	14.0 (0.55)	104.0 (4.09)	30.0 (1.18)
100 (4)	27.0 (1.06)	12.0 (0.47)	94.0 (3.70)	11.0 (0.43)	17.5 x 13.5dp (0.69 x 0.53 dp)	3/8*	18.0 (0.71)	121.9 (4.80)	30.0 (1.18)

BORE	ØT	G
12 (1/2)	15 +0/-0.043 (0.591 +0/-0.002)	1.5 (0.06)
16 (5/8)	20 +0/-0.052 (0.787 +0/-0.002)	1.5 (0.06)
20 (3/4)	13 +0/-0.043 (0.512 +0/-0.002)	2.0 (0.08)
25 (1)	15 +0/-0.043 (0.591 +0/-0.002)	2.0 (0.08)
32 (1-1/4)	21 +0/-0.062 (0.827 +0/-0.002)	2.0 (0.08)
40 (1-1/2)	28 +0/-0.062 (1.102 +0/-0.002)	2.0 (0.08)
50 (2)	35 +0/-0.062 (1.378 +0/-0.002)	2.0 (0.08)
63 (2-1/2)	35 +0/-0.062 (1.378 +0/-0.002)	2.0 (0.08)
80 (3-1/4)	43 +0/-0.062 (1.693 +0/-0.002)	2.0 (0.08)



Universal Series  
Metric Compact Interchangeable



Single Acting, Spring Retract / Spring Extend

Ø12 - Ø16 mm Bores

Spring Retract

Spring Extend

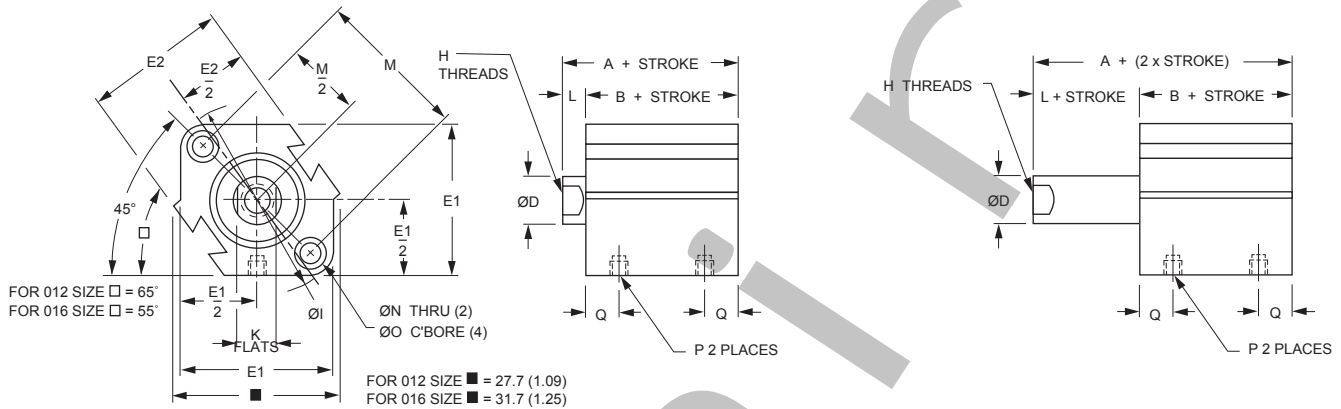

Ø20 - Ø25 mm Bores

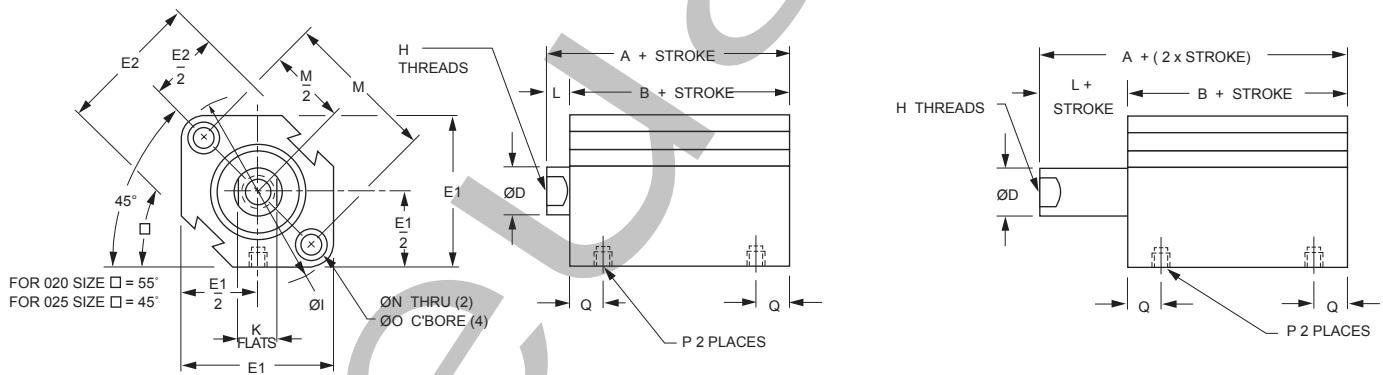

NOTE: See page 5 for complete stroke availability.

Port Size Offerings

- N - NPT ports, inch rod thread
- G - BSP parallel ports, metric rod thread
- P - BSPT taper ports, metric rod thread

NOTE: M5 x 0.8 port will accept #10-32 male thread fittings.

Dimensions measurements in millimeters and inches (in parenthesis)

BORE	STROKE	A	B	ØD	E1	E2	H (THREADS X dp MIN.)	ØI
12 (1/2)	5-10 (0.20-0.39)	20.5 (0.81)	17.0 (0.67)	6.0 (0.24)	25.0 (0.98)	23.0 (0.90)	#8-32 x 0.21dp (M3 x 0.5 - 5dp)	31.5 (1.24)
16 (5/8)	5-10 (0.20-0.39)	22.0 (0.87)	18.5 (0.73)	8.0 (0.32)	29.0 (1.14)	27.2 (1.07)	#8-32 X 0.21dp (M4 x 0.7 - 5dp)	37.1 (1.46)
20 (3/4)	5-10 (0.20-0.39)	24.0 (0.94)	19.5 (0.77)	10.0 (0.39)	36.0 (1.42)	31.2 (1.23)	#10-32 X 0.28dp (M5 x 0.8 - 7dp)	47.0 (1.85)
25 (1)	5-10 (0.20-0.39)	27.5 (1.08)	22.5 (0.86)	12.0 (0.47)	40.0 (1.57)	36.9 (1.45)	1/4-28 X 0.39dp (M6 x 1.0 - 10dp)	51.3 (2.02)
32 (1-1/4)	5 (0.20)	30.0 (1.18)	23.0 (0.91)	16.0 (0.63)	44.5 (1.75)	-	5/16-24 X 0.50dp (M8 x 1.25 - 12dp)	58.9 (2.32)
	10 (0.39)	30.0 (1.18)	23.0 (0.91)	16.0 (0.63)	44.5 (1.75)	-	5/16-24 X 0.50dp (M8 x 1.25 - 12dp)	58.9 (2.32)
40 (1-1/2)	5-10 (0.20-0.39)	36.5 (1.44)	29.5 (1.16)	16.0 (0.63)	52.0 (2.05)	-	3/8-24 X 0.50dp (M8 x 1.25 - 12dp)	69.0 (2.72)
50 (2)	10-20 (0.39-0.79)	38.5 (1.52)	30.5 (1.20)	20.0 (0.79)	63.7 (2.51)	-	1/2-20 X 0.50dp (M10 x 1.5 - 12dp)	84.9 (3.34)



Universal Series  
Metric Compact Interchangeable



Single Acting, Spring Retract / Spring Extend continued

Ø32 - Ø50 mm Bores

Spring Retract

Spring Extend

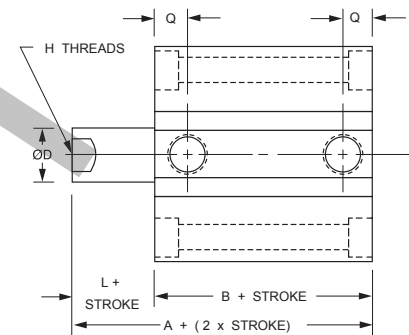
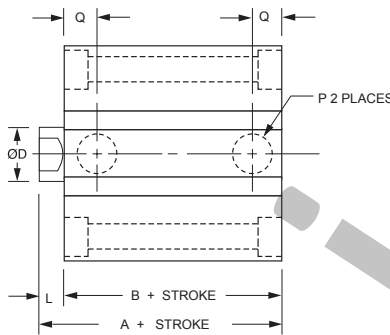
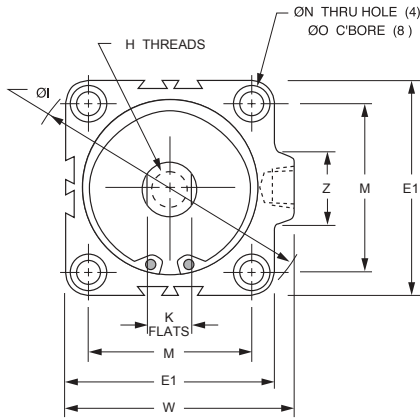

Rod End Male Thread

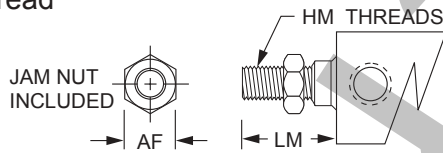

Tapped Hole Mounting

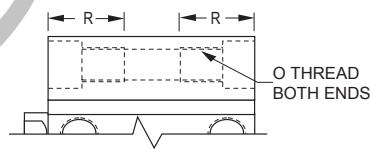

NOTE: Inch threads for 'N' port code.  
Metric threads for 'G' and 'P' port codes.  
Metric for foot, flange, and clevis mount.

BORE MM	AF (HEX) INCH (MM)	HM (THREADS) INCH (MM)	LM RETRACTED INCH (MM)
12	0.34 (8.0)	#8-32 X 0.31 lg (M5 x 0.8-9 lg)	0.45 (14.0)
16	0.34 (10.0)	#8-32 X 0.31 lg (M6 x 1.0-10 lg)	0.45 (15.5)
20	0.38 (13.0)	#10-32 X 0.31 lg (M8 x 1.25-12 lg)	0.49 (18.5)
25	0.43 (17.0)	1/4-28 X 0.37 lg (M10 x 1.25-15 lg)	0.57 (22.5)
32	0.50 (22.0)	5/16-24 X 0.50 lg (M14 x 1.5-20.5 lg)	0.78 (28.5)
40	0.56 (22.0)	3/8-24 X 0.63 lg (M14 x 1.5-20.5 lg)	0.91 (28.5)
50	0.75 (27.0)	1/2-20 X 0.77 lg (M18 x 1.5-26 lg)	1.08 (33.5)

BORE MM	O (THREADS) INCH (MM)	R INCH (MM)
12	#8-32 (M4 x 0.7)	0.43 (11.0)
16	#8-32 (M4 x 0.7)	0.43 (11.0)
20	1/4-20 (M6 x 1.0)	0.67 (17.0)
25	1/4-20 (M6 x 1.0)	0.67 (17.0)
32	1/4-20 (M6 x 1.0)	0.67 (17.0)
40	1/4-20 (M6 x 1.0)	0.75 (19.0)
50	5/16-18 (M8 x 1.25)	0.75 (19.0)

Dimensions measurements in millimeters and inches (in parenthesis)

BORE	K	L	M	ØN	ØO	*P	Q	W	Z
12 (1/2)	5.2 (0.20)	3.5 (0.14)	22.0 (0.87)	3.5 (0.14)	6.5 x 3.5dp (0.26 x 0.14 dp)	M5 x 0.8	7.0 (0.28)	-	-
16 (5/8)	6.0 (0.24)	3.5 (0.14)	28.0 (1.10)	3.5 (0.14)	6.5 x 3.5dp (0.26 x 0.14 dp)	M5 x 0.8	7.8 (0.31)	-	-
20 (3/4)	8.0 (0.31)	4.5 (0.18)	36.0 (1.42)	5.5 (0.22)	9.0 x 7.0dp (0.35 x 0.28 dp)	M5 x 0.8	8.1 (0.32)	-	-
25 (1)	10.0 (0.39)	5.0 (0.20)	40.0 (1.57)	5.5 (0.22)	9.0 x 7.0dp (0.35 x 0.28 dp)	M5 x 0.8	8.4 (0.33)	-	-
32 (1-1/4)	14.0 (0.55)	7.0 (0.28)	34.0 (1.34)	5.5 (0.22)	9.0 x 7.0dp (0.35 x 0.28 dp)	M5 x 0.8	8.7 (0.34)	49.3 (1.94)	21.4 (0.84)
	14.0 (0.55)	7.0 (0.28)	34.0 (1.34)	5.5 (0.22)	9.0 x 7.0dp (0.35 x 0.28 dp)	1/8*	8.7 (0.34)	49.3 (1.94)	21.4 (0.84)
40 (1-1/2)	14.0 (0.55)	7.0 (0.28)	40.0 (1.57)	5.5 (0.22)	9.0 x 7.0dp (0.35 x 0.28 dp)	1/8*	9.2 (0.36)	57.0 (2.24)	21.4 (0.84)
50 (2)	17.0 (0.67)	8.0 (0.31)	50.0 (1.97)	6.6 (0.26)	11.0 x 8.0dp (0.43 x 0.31 dp)	1/4*	10.5 (0.41)	70.6 (2.78)	26.5 (1.04)



Universal Series  
Metric Compact Interchangeable

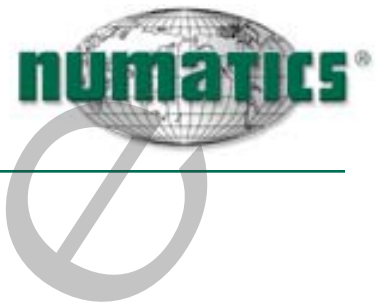

Magnetic Piston, Double Acting, Single Rod

Ø12 - Ø16 mm Bores

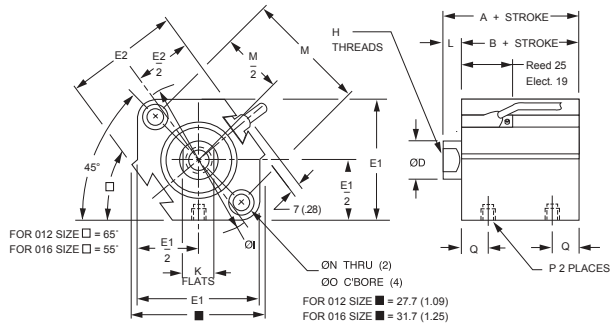

Sensors must be ordered separately, see Sensor section.

Port Size Offerings

N - NPT ports, inch rod thread

G - BSP parallel ports, metric rod thread

P - BSPT taper ports, metric rod thread

NOTE: M5 x 0.8 port with accept #10-32 male thread fittings.

Ø20 - Ø25 mm Bores

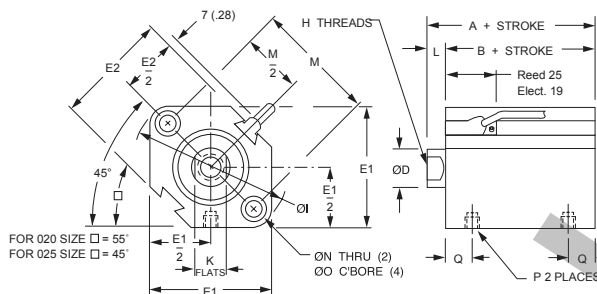

BORE MM	LONG STROKE			EXTENDED STROKE				
	STROKE MM	A	B	Q	STROKE MM	A	B	Q
12	-	-	-	-	50, 75, 100	37.3 (1.47)	33.8 (1.33)	8.9 (0.35)
16	-	-	-	-	50, 75, 100	39.7 (1.56)	36.2 (1.42)	10.2 (0.40)
20	-	-	-	-	75, 100	46.1 (1.82)	41.6 (1.64)	12.1 (0.48)
25	-	-	-	-	75, 100	52.5 (2.07)	47.5 (1.87)	12.7 (0.50)
32	75, 100	40.0 (1.57)	33.0 (1.30)	8.7 (0.34)	125, 150	54.8 (2.16)	47.8 (1.88)	12.7 (0.50)
40	75, 100	46.5 (1.83)	39.5 (1.56)	9.2 (0.36)	125, 150	62.5 (2.46)	55.5 (2.19)	12.7 (0.50)
50	75, 100	48.5 (1.91)	40.5 (1.59)	10.5 (0.41)	125, 150	67.3 (2.65)	59.3 (2.33)	13.2 (0.52)
63	75, 100	54.0 (2.13)	46.0 (1.81)	11.5 (0.45)	125, 150	72.6 (2.86)	64.6 (2.54)	18.5 (0.73)
80	75, 100	63.5 (2.50)	53.5 (2.11)	14.0 (0.55)	125, 150	79.5 (3.13)	69.5 (2.74)	14.0 (0.55)
100	75, 100	75.0 (2.95)	63.0 (2.48)	18.0 (0.71)	125, 150	88.7 (3.49)	76.7 (3.02)	18.0 (0.71)

NOTE: See page 5 for complete stroke availability.

Dimensions measurements in millimeters and inches (in parenthesis)

BORE	STROKE	A	B	ØD	E1	E2	H (THREADS X dp MIN.)	ØI
12 (1/2)	5-30 (0.20-1.18)	31.5 (1.24)	28.0 (1.10)	6.0 (0.24)	25.0 (0.98)	23.0 (0.90)	#8-32 x 0.21dp (M3 x 0.5 - 5dp)	31.5 (1.24)
16 (5/8)	5-30 (0.20-1.18)	34.0 (1.34)	30.5 (1.20)	8.0 (0.32)	29.0 (1.14)	27.2 (1.07)	#8-32 X 0.21dp (M4 x 0.7 - 5dp)	37.1 (1.46)
20 (3/4)	5-50 (0.20-2.0)	36.0 (1.42)	31.5 (1.24)	10.0 (0.39)	36.0 (1.42)	31.2 (1.23)	#10-32 X 0.28dp (M5 x 0.8 - 7dp)	47.0 (1.85)
25 (1)	5-50 (0.20-2.0)	37.5 (1.48)	32.5 (1.28)	12.0 (0.47)	40.0 (1.57)	36.9 (1.45)	1/4-28 X 0.39dp (M6 x 1.0 - 10dp)	51.3 (2.02)
32 (1-1/4)	5-50 (0.20-2.0)	40.0 (1.57)	33.0 (1.30)	16.0 (0.63)	44.5 (1.75)	-	5/16-24 X 0.50dp (M8 x 1.25 - 12dp)	58.9 (2.32)
40 (1-1/2)	5-50 (0.20-2.0)	46.5 (1.83)	39.5 (1.56)	16.0 (0.63)	52.0 (2.05)	-	3/8-24 X 0.50dp (M8 x 1.25 - 12dp)	69.0 (2.72)
50 (2)	10-50 (0.39-2.0)	48.5 (1.91)	40.5 (1.59)	20.0 (0.79)	63.7 (2.51)	-	1/2-20 X 0.50dp (M10 x 1.5 - 12dp)	84.9 (3.34)
63 (2-1/2)	10-50 (0.39-2.0)	54.0 (2.13)	46.0 (1.81)	20.0 (0.79)	76.7 (3.02)	-	1/2-20 X 0.50dp (M10 x 1.5 - 12dp)	101.8 (4.01)
80 (3-1/4)	10-50 (0.39-2.0)	63.5 (2.50)	53.5 (2.11)	25.0 (0.98)	97.8 (3.85)	-	5/8-18 X 0.88dp (M16 x 2.0 - 22dp)	129.8 (5.11)
100 (4)	10-50 (0.39-2.0)	75.0 (2.95)	63.0 (2.48)	30.0 (1.18)	115.3 (4.54)	-	3/4-16 X 0.88dp (M20 x 2.5 - 22dp)	153.9 (6.06)
125 (4.9)	10-300 (0.39-12)	99.0 (3.90)	83.0 (3.27)	36.0 (1.42)	142.0 (5.59)	-	3/4-16 X 1.06dp (M22 x 2.5 - 27dp)	190.0 (7.48)
140 (5-1/2)	10-300 (0.39-12)	99.0 (3.90)	83.0 (3.27)	36.0 (1.42)	158.0 (6.22)	-	3/4-16 X 1.06dp (M22 x 2.5 - 27dp)	210.0 (8.27)
160 (6-1/4)	10-300 (0.39-12)	108.0 (4.25)	91.0 (3.58)	40.0 (1.58)	178.0 (7.01)	-	3/4-16 X 1.06dp (M24 x 3.0 - 27dp)	238.0 (9.37)





Universal Series  
Metric Compact Interchangeable

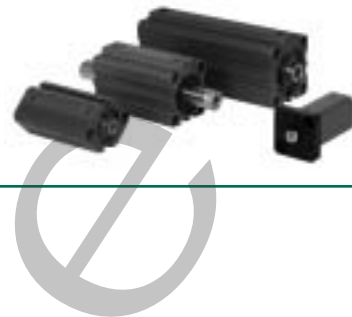

Magnetic Piston, Double Acting, Single Rod continued

Ø32 - Ø160 mm Bores

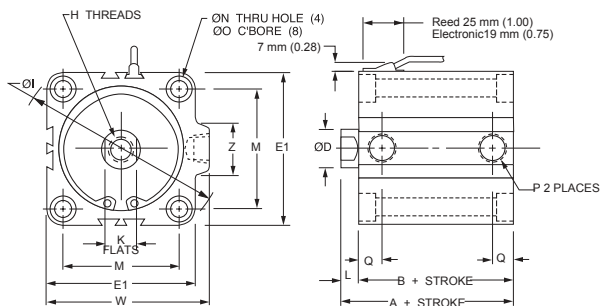

Sensors must be ordered separately, see Sensor section.

Rod End Male Thread

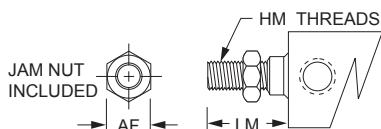

Tapped Hole Mounting

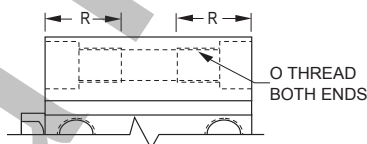

NOTE: Inch threads for 'N' port code.  
Metric threads for 'G' and 'P' port codes.  
Metric for foot, flange, and clevis mount.

BORE MM	AF (HEX) INCH (MM)	HM (THREADS) INCH (MM)	LM INCH (MM)
12	0.34 (8.0)	#8-32 X 0.31 lg (M5 x 0.8-9 lg)	0.45 (14.0)
16	0.34 (10.0)	#8-32 X 0.31 lg (M6 x 1.0-10 lg)	0.45 (15.5)
20	0.38 (13.0)	#10-32 X 0.31 lg (M8 x 1.25-12 lg)	0.49 (18.5)
25	0.43 (17.0)	1/4-28 X 0.37 lg (M10 x 1.25-15 lg)	0.57 (22.5)
32	0.50 (22.0)	5/16-24 X 0.50 lg (M14 x 1.5-20.5 lg)	0.78 (28.5)
40	0.56 (22.0)	3/8-24 X 0.63 lg (M14 x 1.5-20.5 lg)	0.91 (28.5)
50	0.75 (27.0)	1/2-20 X 0.77 lg (M18 x 1.5-26 lg)	1.08 (33.5)
63	0.75 (27.0)	1/2-20 X 0.77 lg (M18 x 1.5-26 lg)	1.08 (33.5)
80	0.93 (32.0)	5/8-18 X 1.0 lg (M22 x 1.5-32.5 lg)	1.40 (43.5)
100	1.13 (46.0)	3/4-16 X 1.12 lg (M26 x 1.5-32.5 lg)	1.59 (43.5)
125	1.13 (46.0)	3/4-16 X 1.12 lg (M30 x 1.5-42 lg)	1.75 (58.0)
140	1.13 (46.0)	3/4-16 X 1.12 lg (M30 x 1.5-42 lg)	1.75 (58.0)
160	1.13 (55.0)	3/4-16 X 1.12 lg (M36 x 1.5-47 lg)	1.79 (64.0)

BORE MM	O (THREADS) INCH (MM)	R INCH (MM)
12	#8-32 (M4 x 0.7)	0.43 (11.0)
16	#8-32 (M4 x 0.7)	0.43 (11.0)
20	1/4-20 (M6 x 1.0)	0.67 (17.0)
25	1/4-20 (M6 x 1.0)	0.67 (17.0)
32	1/4-20 (M6 x 1.0)	0.67 (17.0)
40	1/4-20 (M6 x 1.0)	0.75 (19.0)
50	5/16-18 (M8 x 1.25)	0.75 (19.0)
63	7/16-14 (M10 x 1.5)	0.87 (22.0)
80	1/2-13 (M12 x 1.75)	1.13 (29.0)
100	1/2-13 (M12 x 1.75)	1.13 (29.0)
125	— (M14 x 2.0)	— (45.0)
140	— (M14 x 2.0)	— (45.0)
160	— (M16 x 2.0)	— (50.0)

Dimensions measurements in millimeters and inches (in parenthesis)

BORE	K	L	M	ØN	ØO	*P	Q	W	Z
12 (1/2)	5.0 (0.20)	3.5 (0.14)	22.0 (0.87)	3.5 (0.14)	6.5 x 3.5dp (0.26 x 0.14 dp)	M5 x 0.8	7.0 (0.28)	—	—
16 (5/8)	6.0 (0.24)	3.5 (0.14)	28.0 (1.10)	3.5 (0.14)	6.5 x 3.5dp (0.26 x 0.14 dp)	M5 x 0.8	7.8 (0.31)	—	—
20 (3/4)	8.0 (0.31)	4.5 (0.18)	36.0 (1.42)	5.5 (0.22)	9.0 x 7.0dp (0.35 x 0.28 dp)	M5 x 0.8	8.1 (0.32)	—	—
25 (1)	10.0 (0.39)	5.0 (0.20)	40.0 (1.57)	5.5 (0.22)	9.0 x 7.0dp (0.35 x 0.28 dp)	M5 x 0.8	8.4 (0.33)	—	—
32 (1-1/4)	14.0 (0.55)	7.0 (0.28)	34.0 (1.34)	5.5 (0.22)	9.0 x 7.0dp (0.35 x 0.28 dp)	1/8*	8.7 (0.34)	49.3 (1.94)	21.4 (0.84)
40 (1-1/2)	14.0 (0.55)	7.0 (0.28)	40.0 (1.57)	5.5 (0.22)	9.0 x 7.0dp (0.35 x 0.28 dp)	1/8*	9.2 (0.36)	57.0 (2.24)	21.4 (0.84)
50 (2)	17.0 (0.67)	8.0 (0.31)	50.0 (1.97)	6.6 (0.26)	11.0 x 8.0dp (0.43 x 0.31 dp)	1/4*	10.5 (0.41)	70.6 (2.78)	26.5 (1.04)
63 (2-1/2)	17.0 (0.67)	8.0 (0.31)	60.0 (2.36)	9.0 (0.35)	14.0 x 10.5dp (0.55 x 0.41 dp)	1/4*	11.5 (0.45)	83.6 (3.29)	26.5 (1.04)
80 (3-1/4)	22.0 (0.87)	10.0 (0.39)	77.0 (3.03)	11.0 (0.43)	17.5 x 13.5dp (0.69 x 0.53 dp)	3/8*	14.0 (0.55)	104.0 (4.09)	30.0 (1.18)
100 (4)	27.0 (1.06)	12.0 (0.47)	94.0 (3.70)	11.0 (0.43)	17.5 x 13.5dp (0.69 x 0.53 dp)	3/8*	18.0 (0.71)	121.9 (4.80)	30.0 (1.18)
125 (4.9)	32.0 (1.26)	16.0 (0.63)	114.0 (4.49)	12.7 (0.50)	21.2 x 18.4dp (0.83 x 0.72 dp)	3/8*	24.5 (0.96)	153.0 (6.02)	39.0 (1.53)
140 (5-1/2)	32.0 (1.26)	16.0 (0.63)	128.0 (5.04)	12.7 (0.50)	21.2 x 18.4dp (0.83 x 0.72 dp)	3/8*	24.5 (0.96)	168.0 (6.61)	39.0 (1.53)
160 (6-1/4)	36.0 (1.42)	17.0 (0.67)	144.0 (5.67)	14.5 (0.57)	24.2 x 21.2dp (0.95 x 0.83 dp)	3/8*	27.5 (1.08)	188.0 (7.40)	39.0 (1.53)



Universal Series  
Metric Compact Interchangeable



Magnetic Piston, Double Acting, Double Rod

Ø12 - Ø16 mm Bores

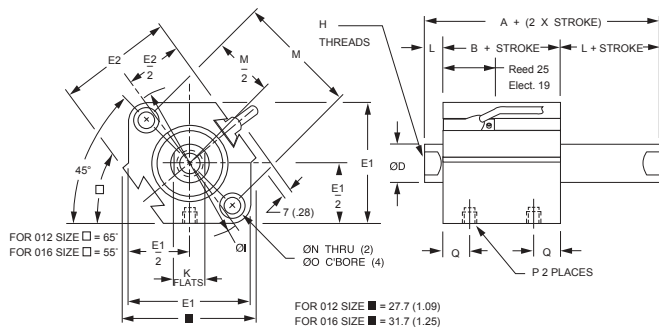

Ø20 - Ø25 mm Bores

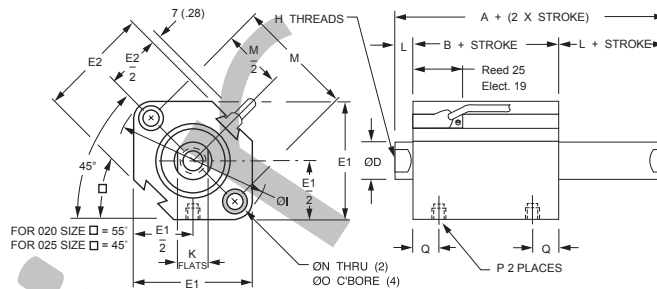

MODEL CODE "T"	
BORE	HOLE SIZE
12	N/A (N/A)
16	1.5 (0.06)
20	1.5 (0.06)
25	3.1 (0.13)
32	3.1 (0.13)
40	3.1 (0.13)
50	4.0 (0.16)
63	4.0 (0.16)
80	6.3 (0.25)
100	6.3 (0.25)
125	6.3 (0.25)
140	6.3 (0.25)
160	12.6 (0.50)

BORE MM	LONG STROKE				EXTENDED STROKE			
	STROKE MM	A	B	Q	STROKE MM	A	B	Q
12	-	-	-	-	50, 75, 100	37.3 (1.47)	33.8 (1.33)	8.9 (0.35)
	-	-	-	-	50, 75, 100	39.7 (1.56)	36.2 (1.42)	10.2 (0.40)
16	-	-	-	-	75, 100	46.1 (1.82)	41.6 (1.64)	12.1 (0.48)
	-	-	-	-	75, 100	52.5 (2.07)	47.5 (1.87)	12.7 (0.50)
20	75, 100	61.8 (2.43)	47.8 (1.88)	12.7 (0.50)	125, 150	54.8 (2.16)	47.8 (1.88)	12.7 (0.50)
	75, 100	69.5 (2.74)	55.5 (2.19)	12.7 (0.50)	125, 150	62.5 (2.46)	55.5 (2.19)	12.7 (0.50)
25	75, 100	75.3 (2.96)	59.3 (2.33)	13.2 (0.52)	125, 150	67.3 (2.65)	59.3 (2.33)	13.2 (0.52)
	75, 100	80.6 (3.17)	64.6 (2.54)	18.5 (0.73)	125, 150	72.6 (2.86)	64.6 (2.54)	18.5 (0.73)
32	75, 100	89.5 (3.52)	69.5 (2.74)	14.0 (0.55)	125, 150	79.5 (3.13)	69.5 (2.74)	14.0 (0.55)
	75, 100	100.7 (3.96)	76.7 (3.02)	18.0 (0.71)	125, 150	88.7 (3.49)	76.7 (3.02)	18.0 (0.71)

NOTE: See page 5 for complete stroke availability.

Dimensions measurements in millimeters and inches (in parenthesis)

BORE	STROKE	A	B	ØD	E1	E2	H (THREADS X dp MIN.)	ØI
12 (1/2)	5-30 (0.20-1.18)	39.4 (1.55)	32.4 (1.28)	6.0 (0.24)	25.0 (0.98)	23.0 (0.90)	#8-32 x 0.21dp (M3 x 0.5 - 5dp)	31.5 (1.24)
16 (5/8)	5-30 (0.20-1.18)	43.0 (1.69)	36.0 (1.42)	8.0 (0.32)	29.0 (1.14)	27.2 (1.07)	#8-32 X 0.21dp (M4 x 0.7 - 5dp)	37.1 (1.46)
20 (3/4)	5-50 (0.20-2.0)	47.0 (1.85)	38.0 (1.50)	10.0 (0.39)	36.0 (1.42)	31.2 (1.23)	#10-32 X 0.28dp (M5 x 0.8 - 7dp)	47.0 (1.85)
25 (1)	5-50 (0.20-2.0)	49.0 (1.93)	39.0 (1.54)	12.0 (0.47)	40.0 (1.57)	36.9 (1.45)	1/4-28 X 0.39dp (M6 x 1.0 - 10dp)	51.3 (2.02)
32 (1-1/4)	5-50 (0.20-2.0)	54.5 (2.15)	40.5 (1.59)	16.0 (0.63)	44.5 (1.75)	-	5/16-24 X 0.50dp (M8 x 1.25 - 12dp)	58.9 (2.32)
40 (1-1/2)	5-50 (0.20-2.0)	64.0 (2.52)	50.0 (1.97)	16.0 (0.63)	52.0 (2.05)	-	3/8-24 X 0.50dp (M8 x 1.25 - 12dp)	69.0 (2.72)
50 (2)	10-50 (0.39-2.0)	66.5 (2.62)	50.5 (1.99)	20.0 (0.79)	63.7 (2.51)	-	1/2-20 X 0.50dp (M10 x 1.5 - 12dp)	84.9 (3.34)
63 (2-1/2)	10-50 (0.39-2.0)	68.0 (2.68)	52.0 (2.05)	20.0 (0.79)	76.7 (3.02)	-	1/2-20 X 0.50dp (M10 x 1.5 - 12dp)	101.8 (4.01)
80 (3-1/4)	10-50 (0.39-2.0)	81.0 (3.19)	61.0 (2.40)	25.0 (0.98)	97.8 (3.85)	-	5/8-18 X 0.88dp (M16 x 2.0 - 22dp)	129.8 (5.11)
100 (4)	10-50 (0.39-2.0)	94.5 (3.72)	70.5 (2.78)	30.0 (1.18)	115.3 (4.54)	-	3/4-16 X 0.88dp (M20 x 2.5 - 22dp)	153.9 (6.06)
125 (4.9)	10-300 (0.39-12)	115.0 (4.53)	83.0 (3.27)	36.0 (1.42)	142.0 (5.59)	-	3/4-16 X 1.06dp (M22 x 2.5 - 27dp)	190.0 (7.48)
140 (5-1/2)	10-300 (0.39-12)	115.0 (4.53)	83.0 (3.27)	36.0 (1.42)	158.0 (6.22)	-	3/4-16 X 1.06dp (M22 x 2.5 - 27dp)	210.0 (8.27)
160 (6-1/4)	10-300 (0.39-12)	125.0 (4.92)	91.0 (3.58)	40.0 (1.58)	178.0 (7.01)	-	3/4-16 X 1.06dp (M24 x 3.0 - 27dp)	238.0 (9.37)



Universal Series  
Metric Compact Interchangeable



Magnetic Piston, Double Acting, Double Rod continued

Ø32 - Ø160 mm Bores

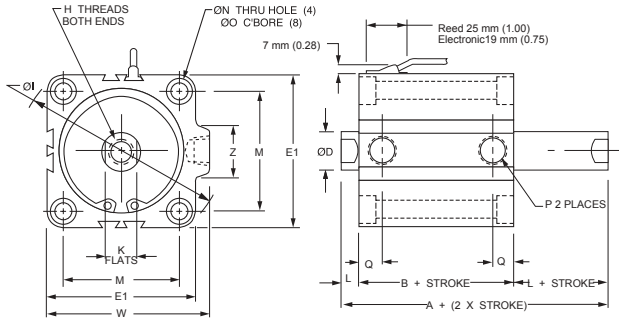

Sensors must be ordered separately, see Sensor section.

Port Size Offerings

- N - NPT ports, inch rod thread
- G - BSP parallel ports, metric rod thread
- P - BSPT taper ports, metric rod thread

NOTE: M5 x 0.8 port will accept #10-32 male thread fittings.

Rod End Male Thread

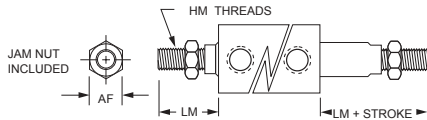

Tapped Hole Mounting

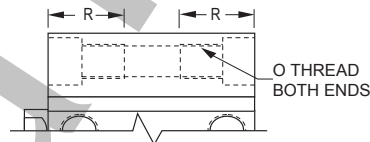

NOTE: Inch threads for 'N' port code. Metric threads for 'G' and 'P' port codes. Metric for foot, flange, and clevis mount.

BORE MM	AF (HEX) INCH (MM)	HM (THREADS) INCH (MM)	LM INCH (MM)
12	0.34 (8.0)	#8-32 X 0.31 lg (M5 x 0.8-9 lg)	0.45 (14.0)
16	0.34 (10.0)	#8-32 X 0.31 lg (M6 x 1.0-10 lg)	0.45 (15.5)
20	0.38 (13.0)	#10-32 X 0.31 lg (M8 x 1.25-12 lg)	0.49 (18.5)
25	0.43 (17.0)	1/4-28 X 0.37 lg (M10 x 1.25-15 lg)	0.57 (22.5)
32	0.50 (22.0)	5/16-24 X 0.50 lg (M14 x 1.5-20.5 lg)	0.78 (28.5)
40	0.56 (22.0)	3/8-24 X 0.63 lg (M14 x 1.5-20.5 lg)	0.91 (28.5)
50	0.75 (27.0)	1/2-20 X 0.77 lg (M18 x 1.5-26 lg)	1.08 (33.5)
63	0.75 (27.0)	1/2-20 X 0.77 lg (M18 x 1.5-26 lg)	1.08 (33.5)
80	0.93 (32.0)	5/8-18 X 1.0 lg (M22 x 1.5-32.5 lg)	1.40 (43.5)
100	1.13 (46.0)	3/4-16 X 1.12 lg (M26 x 1.5-32.5 lg)	1.59 (43.5)
125	1.13 (46.0)	3/4-16 X 1.12 lg (M30 x 1.5-42 lg)	1.75 (58.0)
140	1.13 (46.0)	3/4-16 X 1.12 lg (M30 x 1.5-42 lg)	1.75 (58.0)
160	1.13 (55.0)	3/4-16 X 1.12 lg (M36 x 1.5-47 lg)	1.79 (64.0)

BORE MM	O (THREADS) INCH (MM)	R INCH (MM)
12	#8-32 (M4 x 0.7)	0.43 (11.0)
16	#8-32 (M4 x 0.7)	0.43 (11.0)
20	1/4-20 (M6 x 1.0)	0.67 (17.0)
25	1/4-20 (M6 x 1.0)	0.67 (17.0)
32	1/4-20 (M6 x 1.0)	0.67 (17.0)
40	1/4-20 (M6 x 1.0)	0.75 (19.0)
50	5/16-18 (M8 x 1.25)	0.75 (19.0)
63	7/16-14 (M10 x 1.5)	0.87 (22.0)
80	1/2-13 (M12 x 1.75)	1.13 (29.0)
100	1/2-13 (M12 x 1.75)	1.13 (29.0)
125	- (M14 x 2.0)	- (45.0)
140	- (M14 x 2.0)	- (45.0)
160	- (M16 x 2.0)	- (50.0)

Dimensions measurements in millimeters and inches (in parenthesis)

BORE	K	L	M	ØN	ØØ	*P	Q	W	Z
12 (1/2)	5.0 (0.20)	3.5 (0.14)	22.0 (0.87)	3.5 (0.14)	6.5 x 3.5dp (0.26 x 0.14 dp)	M5 x 0.8	7.0 (0.28)	-	-
16 (5/8)	6.0 (0.24)	3.5 (0.14)	28.0 (1.10)	3.5 (0.14)	6.5 x 3.5dp (0.26 x 0.14 dp)	M5 x 0.8	7.8 (0.31)	-	-
20 (3/4)	8.0 (0.31)	4.5 (0.18)	36.0 (1.42)	5.5 (0.22)	9.0 x 7.0dp (0.35 x 0.28 dp)	M5 x 0.8	8.1 (0.32)	-	-
25 (1)	10.0 (0.39)	5.0 (0.20)	40.0 (1.57)	5.5 (0.22)	9.0 x 7.0dp (0.35 x 0.28 dp)	M5 x 0.8	8.4 (0.33)	-	-
32 (1-1/4)	14.0 (0.55)	7.0 (0.28)	34.0 (1.34)	5.5 (0.22)	9.0 x 7.0dp (0.35 x 0.28 dp)	1/8*	8.7 (0.34)	49.3 (1.94)	21.4 (0.84)
40 (1-1/2)	14.0 (0.55)	7.0 (0.28)	40.0 (1.57)	5.5 (0.22)	9.0 x 7.0dp (0.35 x 0.28 dp)	1/8*	9.2 (0.36)	57.0 (2.24)	21.4 (0.84)
50 (2)	17.0 (0.67)	8.0 (0.31)	50.0 (1.97)	6.6 (0.26)	11.0 x 8.0dp (0.43 x 0.31 dp)	1/4*	10.5 (0.41)	70.6 (2.78)	26.5 (1.04)
63 (2-1/2)	17.0 (0.67)	8.0 (0.31)	60.0 (2.36)	9.0 (0.35)	14.0 x 10.5dp (0.55 x 0.41 dp)	1/4*	11.5 (0.45)	83.6 (3.29)	26.5 (1.04)
80 (3-1/4)	22.0 (0.87)	10.0 (0.39)	77.0 (3.03)	11.0 (0.43)	17.5 x 13.5dp (0.69 x 0.53 dp)	3/8*	14.0 (0.55)	104.0 (4.09)	30.0 (1.18)
100 (4)	27.0 (1.06)	12.0 (0.47)	94.0 (3.70)	11.0 (0.43)	17.5 x 13.5dp (0.69 x 0.53 dp)	3/8*	18.0 (0.71)	121.9 (4.80)	30.0 (1.18)
125 (4.9)	32.0 (1.26)	16.0 (0.63)	114.0 (4.49)	12.7 (0.50)	21.2 x 18.4dp (0.83 x 0.72 dp)	3/8*	24.5 (0.96)	153.0 (6.02)	39.0 (1.53)
140 (5-1/2)	32.0 (1.26)	16.0 (0.63)	128.0 (5.04)	12.7 (0.50)	21.2 x 18.4dp (0.83 x 0.72 dp)	3/8*	24.5 (0.96)	168.0 (6.61)	39.0 (1.53)
160 (6-1/4)	36.0 (1.42)	17.0 (0.67)	144.0 (5.67)	14.5 (0.57)	24.2 x 21.2dp (0.95 x 0.83 dp)	3/8*	27.5 (1.08)	188.0 (7.40)	39.0 (1.53)

Universal Series  
Metric Compact Interchangeable

Magnetic Piston, Double Acting, Nonrotating Piston Rod

Ø12 - Ø16 mm Bores

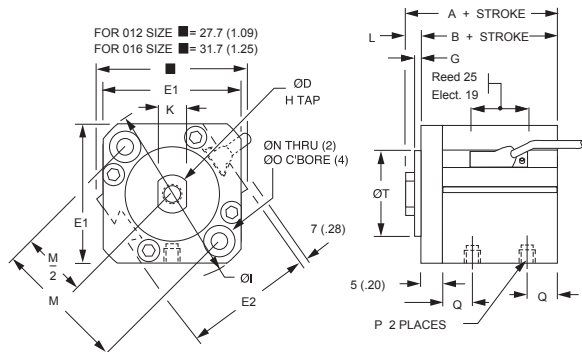

Ø20 - Ø25 mm Bores

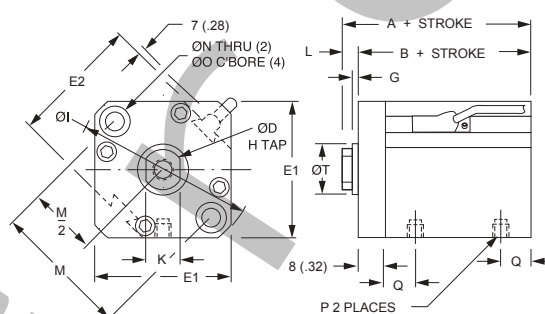

Rod flats (Dim. K) nominally in-line with ports.

Port Size Offerings

N - NPT ports, inch rod thread

G - BSP parallel ports, metric rod thread

P - BSPT taper ports, metric rod thread

NOTE: M5 x 0.8 port will accept #10-32 male thread fittings.

WARNING: This cylinder has a non-rotating rod.

To prevent internal damage hold rod by flats ONLY WHEN FULLY RETRACTED while installing or removing attachments. DO NOT scratch or dent shaft.

Sensors must be ordered separately, see Sensor section.

BORE SIZE	12	16	20	25	32	40	50	63	80	100
NON-ROTATING ROD ACCURACY	±2°	±1°	±1°	±1°	±0.8°	±0.8°	±0.8°	±0.8°	±0.8°	±0.8°

BORE MM	STROKE MM	LONG STROKE			EXTENDED STROKE			
		A	B	Q	STROKE MM	A	B	Q
12	-	-	-	-	50, 75, 100	42.3 (1.67)	38.8 (1.53)	8.9 (0.35)
16	-	-	-	-	50, 75, 100	44.7 (1.76)	41.2 (1.62)	10.2 (0.40)
20	-	-	-	-	75, 100	54.1 (2.13)	46.9 (1.95)	12.1 (0.48)
25	-	-	-	-	75, 100	60.5 (2.38)	55.5 (2.19)	12.7 (0.50)
32	75, 100	49.0 (1.93)	42.0 (1.65)	8.7 (0.34)	125, 150	63.8 (2.51)	56.8 (2.24)	12.7 (0.50)
40	75, 100	46.5 (1.83)	39.5 (1.56)	9.2 (0.36)	125, 150	62.5 (2.46)	55.5 (2.19)	12.7 (0.50)
50	75, 100	48.5 (1.91)	40.5 (1.59)	10.5 (0.41)	125, 150	67.3 (2.65)	59.3 (2.33)	13.2 (0.52)
63	75, 100	54.0 (2.13)	46.0 (1.81)	11.5 (0.45)	125, 150	72.6 (2.86)	64.6 (2.54)	18.5 (0.73)
80	75, 100	63.5 (2.50)	53.5 (2.11)	14.0 (0.55)	125, 150	79.5 (3.13)	69.5 (2.74)	14.0 (0.55)
100	75, 100	75.0 (2.95)	63.0 (2.48)	18.0 (0.71)	125, 150	88.7 (3.49)	76.7 (3.02)	18.0 (0.71)

NOTE: See page 5 for complete stroke availability.

Dimensions measurements in millimeters and inches (in parenthesis)

BORE	STROKE	A	B	ØD	E1	E2	H (THREADS X dp MIN.)	ØI
12 (1/2)	5-30 (0.20-1.18)	36.5 (1.44)	33.0 (1.30)	6.0 (0.24)	25.0 (0.98)	23.0 (0.90)	#8-32 x 0.21dp (M3 x 0.5 - 5dp)	31.5 (1.24)
16 (5/8)	5-30 (0.20-1.18)	39.0 (1.54)	35.5 (1.40)	8.0 (0.32)	29.0 (1.14)	27.2 (1.07)	#8-32 X 0.21dp (M4 x 0.7 - 5dp)	37.1 (1.46)
20 (3/4)	5-50 (0.20-2.0)	44.0 (1.73)	39.5 (1.56)	10.0 (0.39)	36.0 (1.42)	31.2 (1.23)	#10-32 X 0.28dp (M5 x 0.8 - 7dp)	47.0 (1.85)
25 (1)	5-50 (0.20-2.0)	45.5 (1.79)	40.5 (1.59)	12.0 (0.47)	40.0 (1.57)	36.9 (1.45)	1/4-28 X 0.39dp (M6 x 1.0 - 10dp)	51.3 (2.02)
32 (1-1/4)	5-50 (0.20-2.0)	49.0 (1.93)	42.0 (1.65)	16.0 (0.63)	44.5 (1.75)	-	5/16-24 X 0.50dp (M8 x 1.25 - 12dp)	58.9 (2.32)
40 (1-1/2)	5-50 (0.20-2.0)	46.5 (1.83)	39.5 (1.56)	16.0 (0.63)	52.0 (2.05)	-	3/8-24 X 0.50dp (M8 x 1.25 - 12dp)	69.0 (2.72)
50 (2)	10-50 (0.39-2.0)	48.5 (1.91)	40.5 (1.59)	20.0 (0.79)	63.7 (2.51)	-	1/2-20 X 0.50dp (M10 x 1.5 - 12dp)	84.9 (3.34)
63 (2-1/2)	10-50 (0.39-2.0)	54.0 (2.13)	46.0 (1.81)	20.0 (0.79)	76.7 (3.02)	-	1/2-20 X 0.50dp (M10 x 1.5 - 12dp)	101.8 (4.01)
80 (3-1/4)	10-50 (0.39-2.0)	63.5 (2.50)	53.5 (2.11)	25.0 (0.98)	97.8 (3.85)	-	5/8-18 X 0.88dp (M16 x 2.0 - 22dp)	129.8 (5.11)



## Magnetic Piston, Double Acting, Nonrotating Piston Rod continued

### Ø32 mm Bores

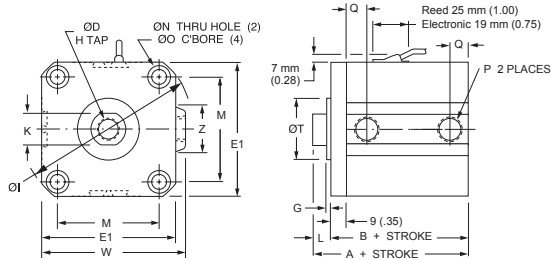

### Ø40 - Ø100 mm Bores

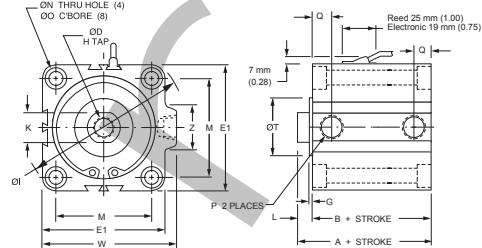

### Rod End Male Thread

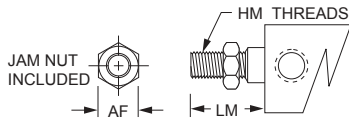

Rod flats (Dim. K) nominally in-line with ports.

### Tapped Hole Mounting

NOTE: Inch threads for 'N' port code.  
Metric threads for 'G' and 'P' port codes.  
Metric for foot, flange, and clevis mount.

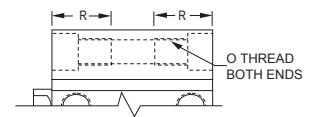

BORE MM	AF (HEX) INCH (MM)	HM (THREADS) INCH (MM)	LM INCH (MM)
12	0.34 (8.0)	#8-32 X 0.31 lg (M5 x 0.8-9 lg)	0.45 (14.0)
16	0.34 (10.0)	#8-32 X 0.31 lg (M6 x 1.0-10 lg)	0.45 (15.5)
20	0.38 (13.0)	#10-32 X 0.31 lg (M8 x 1.25-12 lg)	0.49 (18.5)
25	0.43 (17.0)	1/4-28 X 0.37 lg (M10 x 1.25-15 lg)	0.57 (22.5)
32	0.50 (22.0)	5/16-24 X 0.50 lg (M14 x 1.5-20.5 lg)	0.78 (28.5)
40	0.56 (22.0)	3/8-24 X 0.63 lg (M14 x 1.5-20.5 lg)	0.91 (28.5)
50	0.75 (27.0)	1/2-20 X 0.77 lg (M18 x 1.5-26 lg)	1.08 (33.5)
63	0.75 (27.0)	1/2-20 X 0.77 lg (M18 x 1.5-26 lg)	1.08 (33.5)
80	0.93 (32.0)	5/8-18 X 1.0 lg (M22 x 1.5-32.5 lg)	1.40 (43.5)
100	1.13 (46.0)	3/4-16 X 1.12 lg (M26 x 1.5-32.5 lg)	1.59 (43.5)

BORE MM	O (THREADS) INCH (MM)	PLACES FRONT	RF INCH (MM)	PLACES REAR	RR INCH (MM)
12	#8-32 (M4 x 0.7)	2	0.63 (16.0)	2	0.43 (11.0)
16	#8-32 (M4 x 0.7)	2	0.63 (16.0)	2	0.43 (11.0)
20	1/4-20 (M6 x 1.0)	2	0.98 (25.0)	2	0.67 (17.0)
25	1/4-20 (M6 x 1.0)	2	0.98 (25.0)	2	0.67 (17.0)
32	1/4-20 (M6 x 1.0)	2	1.02 (26.0)	4	0.67 (17.0)
40	1/4-20 (M6 x 1.0)	4	0.75 (19.0)	4	0.75 (19.0)
50	5/16-18 (M8 x 1.25)	4	0.75 (19.0)	4	0.75 (19.0)
63	7/16-14 (M10 x 1.5)	4	0.87 (22.0)	4	0.87 (22.0)
80	1/2-13 (M12 x 1.75)	4	1.13 (29.0)	4	1.13 (29.0)
100	1/2-13 (M12 x 1.75)	4	1.13 (29.0)	4	1.13 (29.0)

### Dimensions measurements in millimeters and inches (in parenthesis)

BORE	K	L	M	ØN	ØO	*P	Q	W	Z
12 (1/2)	5.2 (0.20)	3.5 (0.14)	22.0 (0.87)	3.5 (0.14)	6.5 x 3.5dp (0.26 x 0.14 dp)	M5 x 0.8	7.0 (0.28)	-	-
16 (5/8)	6.0 (0.24)	3.5 (0.14)	28.0 (1.10)	3.5 (0.14)	6.5 x 3.5dp (0.26 x 0.14 dp)	M5 x 0.8	7.8 (0.31)	-	-
20 (3/4)	8.0 (0.31)	4.5 (0.18)	36.0 (1.42)	5.5 (0.22)	9.0 x 7.0dp (0.35 x 0.28 dp)	M5 x 0.8	8.1 (0.32)	-	-
25 (1)	10.0 (0.39)	5.0 (0.20)	40.0 (1.57)	5.5 (0.22)	9.0 x 7.0dp (0.35 x 0.28 dp)	M5 x 0.8	8.4 (0.33)	-	-
32 (1-1/4)	14.0 (0.55)	7.0 (0.28)	34.0 (1.34)	5.5 (0.22)	9.0 x 7.0dp (0.35 x 0.28 dp)	1/8*	8.7 (0.34)	49.3 (1.94)	21.4 (0.84)
40 (1-1/2)	14.0 (0.55)	7.0 (0.28)	40.0 (1.57)	5.5 (0.22)	9.0 x 7.0dp (0.35 x 0.28 dp)	1/8*	9.2 (0.36)	57.0 (2.24)	21.4 (0.84)
50 (2)	18.0 (0.71)	8.0 (0.31)	50.0 (1.97)	6.6 (0.26)	11.0 x 8.0dp (0.43 x 0.31 dp)	1/4*	10.5 (0.41)	70.6 (2.78)	26.5 (1.04)
63 (2-1/2)	18.0 (0.71)	8.0 (0.31)	60.0 (2.36)	9.0 (0.35)	14.0 x 10.5dp (0.55 x 0.41 dp)	1/4*	11.5 (0.45)	83.6 (3.29)	26.5 (1.04)
80 (3-1/4)	22.0 (0.87)	10.0 (0.39)	77.0 (3.03)	11.0 (0.43)	17.5 x 13.5dp (0.69 x 0.53 dp)	3/8*	14.0 (0.55)	104.0 (4.09)	30.0 (1.18)
100 (4)	27.0 (1.06)	12.0 (0.47)	94.0 (3.70)	11.0 (0.43)	17.5 x 13.5dp (0.69 x 0.53 dp)	3/8*	18.0 (0.71)	121.9 (4.80)	30.0 (1.18)

BORE	ØT	G
12 (1/2)	15 +0/-0.043 (0.591 +0/-0.002)	1.5 (0.06)
16 (5/8)	20 +0/-0.052 (0.787 +0/-0.002)	1.5 (0.06)
20 (3/4)	13 +0/-0.043 (0.512 +0/-0.002)	2.0 (0.08)
25 (1)	15 +0/-0.043 (0.591 +0/-0.002)	2.0 (0.08)
32 (1-1/4)	21 +0/-0.062 (0.827 +0/-0.002)	2.0 (0.08)
40 (1-1/2)	28 +0/-0.062 (1.102 +0/-0.002)	2.0 (0.08)
50 (2)	35 +0/-0.062 (1.378 +0/-0.002)	2.0 (0.08)
63 (2-1/2)	35 +0/-0.062 (1.378 +0/-0.002)	2.0 (0.08)
80 (3-1/4)	43 +0/-0.062 (1.693 +0/-0.002)	2.0 (0.08)

Universal Series  
Metric Compact Interchangeable

Magnetic Piston, Double Acting, Double Rod, Non-Rotating Piston Rod

Ø12 - Ø16 mm Bores

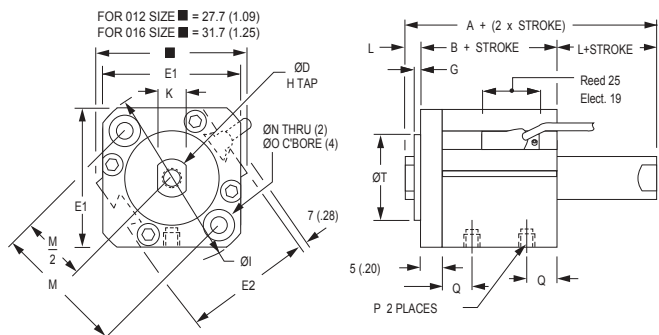

Ø20 - Ø25 mm Bores

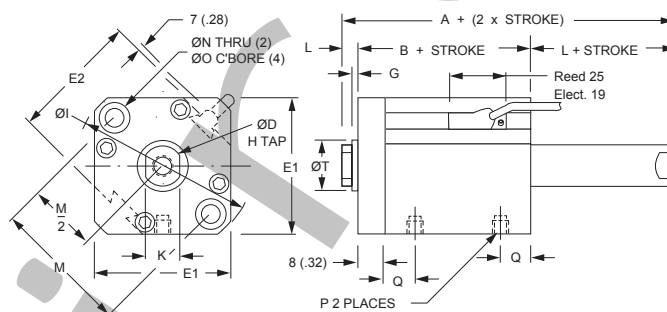

Rod flats (Dim. K) nominally in-line with ports.

Port Size Offerings

N - NPT ports, inch rod thread

G - BSP parallel ports, metric rod thread

P - BSPT taper ports, metric rod thread

NOTE: M5 x 0.8 port will accept #10-32 male thread fittings.

**WARNING:** This cylinder has a non-rotating rod. To prevent internal damage hold rod by flats **ONLY WHEN FULLY RETRACTED** while installing or removing attachments. **DO NOT** scratch or dent shaft.

BORE SIZE	12	16	20	25	32	40	50	63	80	100
NON-ROTATING ROD ACCURACY	±2°	±1°	±1°	±1°	±0.8°	±0.8°	±0.8°	±0.8°	±0.8°	±0.8°

MODEL CODE "M"	
BORE	HOLE SIZE
12	N/A (N/A)
16	1.5 (0.06)
20	1.5 (0.06)
25	3.1 (0.13)
32	3.1 (0.13)
40	3.1 (0.13)
50	4.0 (0.16)
63	4.0 (0.16)
80	6.3 (0.25)
100	6.3 (0.25)

BORE MM	STROKE MM	LONG STROKE			EXTENDED STROKE			
		A	B	Q	STROKE MM	A	B	Q
12	-	-	-	-	50, 75, 100	45.8 (1.80)	38.8 (1.53)	8.9 (0.35)
16	-	-	-	-	50, 75, 100	48.2 (1.90)	41.2 (1.62)	10.2 (0.40)
20	-	-	-	-	75, 100	58.6 (2.31)	49.6 (1.95)	12.1 (0.48)
25	-	-	-	-	75, 100	65.5 (2.58)	55.5 (2.19)	12.7 (0.50)
32	75, 100	70.8 (2.79)	56.8 (2.24)	8.7 (0.34)	125, 150	70.8 (2.79)	56.8 (2.24)	12.7 (0.50)
40	75, 100	69.5 (2.74)	55.5 (2.19)	9.2 (0.36)	125, 150	69.5 (2.74)	55.5 (2.19)	12.7 (0.50)
50	75, 100	75.3 (2.96)	59.3 (2.33)	10.5 (0.41)	125, 150	75.3 (2.96)	59.3 (2.33)	13.2 (0.52)
63	75, 100	80.6 (3.17)	64.6 (2.54)	11.5 (0.45)	125, 150	80.6 (3.17)	64.6 (2.54)	18.5 (0.73)
80	75, 100	89.5 (3.52)	69.5 (2.74)	14.0 (0.55)	125, 150	79.5 (3.13)	69.5 (2.74)	14.0 (0.55)
100	75, 100	100.7 (3.96)	76.7 (3.02)	18.0 (0.71)	125, 150	88.7 (3.49)	76.7 (3.02)	18.0 (0.71)

Dimensions measurements in millimeters and inches (in parenthesis)

NOTE: See page 5 for complete stroke availability.

BORE	STROKE	A	B	ØD	E1	E2	H (THREADS X dp MIN.)	ØI
12 (1/2)	5-30 (0.20-1.18)	44.4 (1.75)	37.4 (1.47)	6.0 (0.24)	25.0 (0.98)	23.0 (0.90)	#8-32 x 0.21dp (M3 x 0.5 - 5dp)	31.5 (1.24)
16 (5/8)	5-30 (0.20-1.18)	48.0 (1.89)	41.0 (1.61)	8.0 (0.32)	29.0 (1.14)	27.2 (1.07)	#8-32 X 0.21dp (M4 x 0.7 - 5dp)	37.1 (1.46)
20 (3/4)	5-50 (0.20-2.0)	55.0 (2.17)	46.0 (1.81)	10.0 (0.39)	36.0 (1.42)	31.2 (1.23)	#10-32 X 0.28dp (M5 x 0.8 - 7dp)	47.0 (1.85)
25 (1)	5-50 (0.20-2.0)	57.0 (2.24)	47.0 (1.85)	12.0 (0.47)	40.0 (1.57)	36.9 (1.45)	1/4-28 X 0.39dp (M6 x 1.0 - 10dp)	51.3 (2.02)
32 (1-1/4)	5-50 (0.20-2.0)	63.5 (2.50)	49.5 (1.95)	16.0 (0.63)	44.5 (1.75)	-	5/16-24 X 0.50dp (M8 x 1.25 - 12dp)	58.9 (2.32)
40 (1-1/2)	5-50 (0.20-2.0)	64.0 (2.52)	50.0 (1.97)	16.0 (0.63)	52.0 (2.05)	-	3/8-24 X 0.50dp (M8 x 1.25 - 12dp)	69.0 (2.72)
50 (2)	10-50 (0.39-2.0)	66.5 (2.62)	50.5 (1.99)	20.0 (0.79)	63.7 (2.51)	-	1/2-20 X 0.50dp (M10 x 1.5 - 12dp)	84.9 (3.34)
63 (2-1/2)	10-50 (0.39-2.0)	68.0 (2.68)	52.0 (2.05)	20.0 (0.79)	76.7 (3.02)	-	1/2-20 X 0.50dp (M10 x 1.5 - 12dp)	101.8 (4.01)
80 (3-1/4)	10-50 (0.39-2.0)	81.0 (3.19)	61.0 (2.40)	25.0 (0.98)	97.8 (3.85)	-	5/8-18 X 0.88dp (M16 x 2.0 - 22dp)	129.8 (5.11)
100 (4)	10-50 (0.39-2.0)	94.5 (3.72)	70.5 (2.78)	30.0 (1.18)	115.3 (4.54)	-	3/4-16 X 0.88dp (M20 x 2.5 - 22dp)	153.9 (6.06)



Universal Series  
Metric Compact Interchangeable



Magnetic Piston, Double Acting, Double Rod, Non-Rotating Piston Rod continued  
Ø32 mm Bores      Ø40 - Ø100 mm Bores

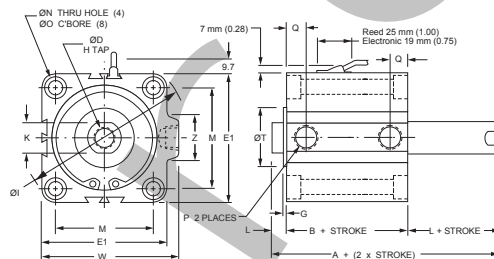
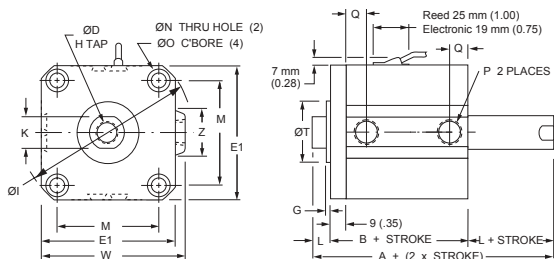

Rod End Male Thread

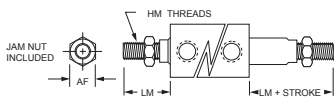

Tapped Hole Mounting

NOTE: Inch threads for 'N' port code.  
Metric threads for 'G' and 'P' port codes.  
Metric for foot, flange, and clevis mount.

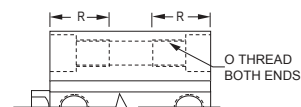

BORE MM	AF (HEX) INCH (MM)	HM (THREADS) INCH (MM)	LM INCH (MM)
12	0.34 (8.0)	#8-32 X 0.31 lg (M5 x 0.8-9 lg)	0.45 (14.0)
16	0.34 (10.0)	#8-32 X 0.31 lg (M6 x 1.0-10 lg)	0.45 (15.5)
20	0.38 (13.0)	#10-32 X 0.31 lg (M8 x 1.25-12 lg)	0.49 (18.5)
25	0.43 (17.0)	1/4-28 X 0.37 lg (M10 x 1.25-15 lg)	0.57 (22.5)
32	0.50 (22.0)	5/16-24 X 0.50 lg (M14 x 1.5-20.5 lg)	0.78 (28.5)
40	0.56 (22.0)	3/8-24 X 0.63 lg (M14 x 1.5-20.5 lg)	0.91 (28.5)
50	0.75 (27.0)	1/2-20 X 0.77 lg (M18 x 1.5-26 lg)	1.08 (33.5)
63	0.75 (27.0)	1/2-20 X 0.77 lg (M18 x 1.5-26 lg)	1.08 (33.5)
80	0.93 (32.0)	5/8-18 X 1.0 lg (M22 x 1.5-32.5 lg)	1.40 (43.5)
100	1.13 (46.0)	3/4-16 X 1.12 lg (M26 x 1.5-32.5 lg)	1.59 (43.5)

BORE MM	O (THREADS) INCH (MM)	PLACES FRONT	RF INCH (MM)	PLACES REAR	RR INCH (MM)
12	#8-32 (M4 x 0.7)	2	0.63 (16.0)	2	0.43 (11.0)
16	#8-32 (M4 x 0.7)	2	0.63 (16.0)	2	0.43 (11.0)
20	1/4-20 (M6 x 1.0)	2	0.98 (25.0)	2	0.67 (17.0)
25	1/4-20 (M6 x 1.0)	2	0.98 (25.0)	2	0.67 (17.0)
32	1/4-20 (M6 x 1.0)	2	1.02 (26.0)	4	0.67 (17.0)
40	1/4-20 (M6 x 1.0)	4	0.75 (19.0)	4	0.75 (19.0)
50	5/16-18 (M8 x 1.25)	4	0.75 (19.0)	4	0.75 (19.0)
63	7/16-14 (M10 x 1.5)	4	0.87 (22.0)	4	0.87 (22.0)
80	1/2-13 (M12 x 1.75)	4	1.13 (29.0)	4	1.13 (29.0)
100	1/2-13 (M12 x 1.75)	4	1.13 (29.0)	4	1.13 (29.0)

Dimensions measurements in millimeters and inches (in parenthesis)

BORE	K	L	M	ØN	ØO	*P	Q	W	Z
12 (1/2)	5.2 (0.20)	3.5 (0.14)	22.0 (0.87)	3.5 (0.14)	6.5 x 3.5dp (0.26 x 0.14 dp)	M5 x 0.8	7.0 (0.28)	-	-
16 (5/8)	6.0 (0.24)	3.5 (0.14)	28.0 (1.10)	3.5 (0.14)	6.5 x 3.5dp (0.26 x 0.14 dp)	M5 x 0.8	7.8 (0.31)	-	-
20 (3/4)	8.0 (0.31)	4.5 (0.18)	36.0 (1.42)	5.5 (0.22)	9.0 x 7.0dp (0.35 x 0.28 dp)	M5 x 0.8	8.1 (0.32)	-	-
25 (1)	10.0 (0.39)	5.0 (0.20)	40.0 (1.57)	5.5 (0.22)	9.0 x 7.0dp (0.35 x 0.28 dp)	M5 x 0.8	8.4 (0.33)	-	-
32 (1-1/4)	14.0 (0.55)	7.0 (0.28)	34.0 (1.34)	5.5 (0.22)	9.0 x 7.0dp (0.35 x 0.28 dp)	1/8*	8.7 (0.34)	49.3 (1.94)	21.4 (0.84)
40 (1-1/2)	14.0 (0.55)	7.0 (0.28)	40.0 (1.57)	5.5 (0.22)	9.0 x 7.0dp (0.35 x 0.28 dp)	1/8*	9.2 (0.36)	57.0 (2.24)	21.4 (0.84)
50 (2)	18.0 (0.71)	8.0 (0.31)	50.0 (1.97)	6.6 (0.26)	11.0 x 8.0dp (0.43 x 0.31 dp)	1/4*	10.5 (0.41)	70.6 (2.78)	26.5 (1.04)
63 (2-1/2)	18.0 (0.71)	8.0 (0.31)	60.0 (2.36)	9.0 (0.35)	14.0 x 10.5dp (0.55 x 0.41 dp)	1/4*	11.5 (0.45)	83.6 (3.29)	26.5 (1.04)
80 (3-1/4)	22.0 (0.87)	10.0 (0.39)	77.0 (3.03)	11.0 (0.43)	17.5 x 13.5dp (0.69 x 0.53 dp)	3/8*	14.0 (0.55)	104.0 (4.09)	30.0 (1.18)
100 (4)	27.0 (1.06)	12.0 (0.47)	94.0 (3.70)	11.0 (0.43)	17.5 x 13.5dp (0.69 x 0.53 dp)	3/8*	18.0 (0.71)	121.9 (4.80)	30.0 (1.18)

BORE	ØT	G
12 (1/2)	15 +0/-0.043 (0.591 +0/-0.002)	1.5 (0.06)
16 (5/8)	20 +0/-0.052 (0.787 +0/-0.002)	1.5 (0.06)
20 (3/4)	13 +0/-0.043 (0.512 +0/-0.002)	2.0 (0.08)
25 (1)	15 +0/-0.043 (0.591 +0/-0.002)	2.0 (0.08)
32 (1-1/4)	21 +0/-0.062 (0.827 +0/-0.002)	2.0 (0.08)
40 (1-1/2)	28 +0/-0.062 (1.102 +0/-0.002)	2.0 (0.08)
50 (2)	35 +0/-0.062 (1.378 +0/-0.002)	2.0 (0.08)
63 (2-1/2)	35 +0/-0.062 (1.378 +0/-0.002)	2.0 (0.08)
80 (3-1/4)	43 +0/-0.062 (1.693 +0/-0.002)	2.0 (0.08)
100 (4)	59 +0/-0.074 (2.323 +0/-0.003)	2.0 (0.08)



Universal Series  
Metric Compact Interchangeable



## Magnetic Piston Adjustable Extend Stroke

**Adjustable Extend Stroke Cylinders** – The Universal Series offers an adjustable extend stroke cylinder to provide a rugged, precision adjustment of the cylinder extend stroke.

Cylinders are offered in double acting models in bore sizes of 32mm through 100mm with 25mm standard adjustment. Magnetic pistons are included for use with any of the electronic or reed sensors.

**Operator Safety** – The stop tube, adjustment nut with skirt, and minimum clearances combine to eliminate pinch points.

**Construction** – The stop tube is black anodized aluminum. The adjustment nut is blackened steel with a black anodized aluminum skirt. The stop flange is red anodized aluminum: all for corrosion resistance and appearance. The adjustment nut, steel for long life, includes a lock screw with a plastic plug so the adjustment nut can be locked in place without damaging the threads. Precision adjustment is achieved with fine pitch threads on the adjustment rod. The stop flange is mounted on the end of the adjustment rod so the nut will not come off.

**Adjustment** – Adjustment settings are simplified by the convenient scale markings. Bores 32 and 40 have a 1/2-20 thread giving .050" (1.3mm) adjustment per nut revolution. Bores 50 and larger have a 3/4-16 thread giving .063" (1.6mm) adjustment per revolution.

### How to Order

**Example 1:** To order a 63mm bore, 75mm stroke unit with standard adjustment of 25mm, NPT ports, and rod end tap mount, specify  
Model No. UND-AA063-075D

For over 25mm adjustment specify the desired adjustment as a suffix option.

**Example 2:** To order the same cylinder with a 50mm adjustment, specify  
Model No. UND-AA063-075D-050

**Example 3:** Also available with non-rotating rod; use body length 'B' dimension from *page 22*, tapped hole mounting information from *page 23* and insert the non-rotating rod Code 'K' in model number. To order 63mm bore, 75mm stroke, nonrotating rod, 50mm adjustment, NPT ports, and ISO flange specify

Model No. UND-AKG063-075D-050

Note – When ordering units with flange or foot mounts, the rod stickout (Dim. "L") increases per dimension on *page 27-28*.

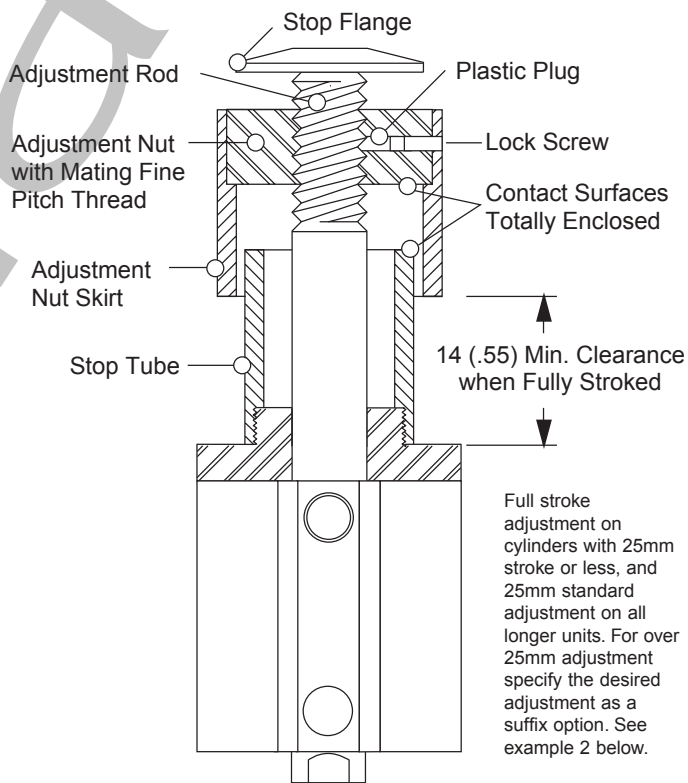

### Dimensions measurements in millimeters and inches (in parenthesis)

BORE	STROKE		ØD	E1	H (THREADS X dp MIN.)	ØI	K	L
	15, 25, 50 MM B	75, 100, 125, 150 MM B						
32 (1-1/4)	40.5 (1.59)	47.8 (1.88)	16.0 (0.63)	44.5 (1.75)	5/16-24 X 0.52dp (M8 x 1.25 - 13dp)	58.9 (2.32)	14.0 (0.55)	7.0 (0.28)
40 (1-1/2)	50.0 (1.97)	55.5 (2.19)	16.0 (0.63)	52.0 (2.05)	3/8-24 X 0.72dp (M8 x 1.25 - 13dp)	69.0 (2.72)	14.0 (0.55)	7.0 (0.28)
50 (2)	50.5 (1.99)	59.3 (2.33)	20.0 (0.79)	63.7 (2.51)	1/2-20 X 0.69dp (M10 x 1.5 - 12dp)	84.9 (3.34)	17.0 (0.67)	8.0 (0.31)
63 (2-1/2)	52.0 (2.05)	64.6 (2.54)	20.0 (0.79)	76.7 (3.02)	1/2-20 X 0.69dp (M10 x 1.5 - 12dp)	101.8 (4.01)	17.0 (0.67)	8.0 (0.31)
80 (3-1/4)	61.0 (2.40)	69.5 (2.74)	25.0 (0.98)	97.8 (3.85)	5/8-18 X 0.96dp (M16 x 2.0 - 21dp)	129.8 (5.11)	22.0 (0.87)	10.0 (0.39)
100 (4)	70.5 (2.78)	76.7 (3.02)	30.0 (1.18)	115.3 (4.54)	3/4-16 X 1.06dp (M20 x 2.5 - 30dp)	153.9 (6.06)	27.0 (1.06)	12.0 (0.47)





Magnetic Piston Adjustable Extend Stroke continued

Standard mounting – Code "A" Tapped Holes  
4 places useable at rod end only. Also includes 2 thru holes ØN w/c'bore ØO  
Optional mounting –  
Code "E" Front Flange  
Code "G" ISO Front Flange  
Code "L" Foot Mount  
NOTE: Use caution when mounting to avoid creating pinch points with other parts of your machinery.

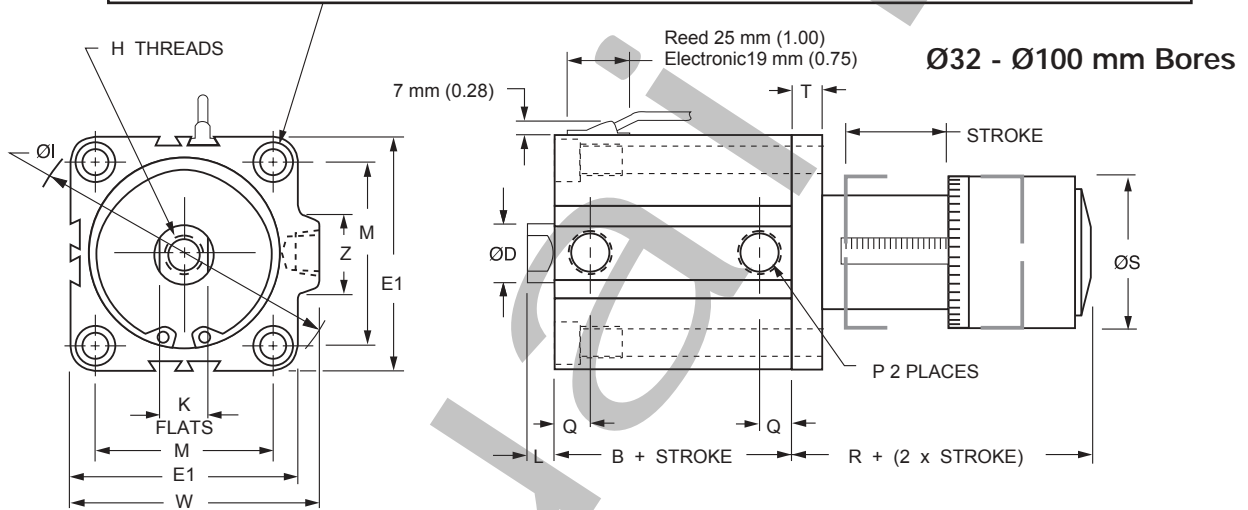

Port Size Offerings

- N - NPT ports, inch rod thread
- G - BSP parallel ports, metric rod thread
- P - BSPT taper ports, metric rod thread

Also available with Nonrotating rod, see page 23, example 3.  
Sensors must be ordered separately, see Sensor section.

Rod End Male Thread

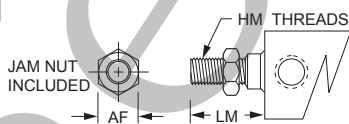

Tapped Hole Mounting

NOTE: Inch threads for 'N' port code.  
Metric threads for 'G' and 'P' port codes.  
Metric for foot, flange, and clevis mount.

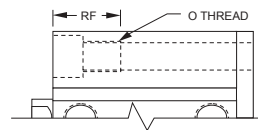

BORE MM	AF (HEX) INCH (MM)	HM (THREADS) INCH (MM)	LM INCH (MM)
32	0.50 (22.0)	5/16-24 X 0.50 lg (M14 x 1.5-20.5 lg)	0.78 (28.5)
40	0.56 (22.0)	3/8-24 X 0.63 lg (M14 x 1.5-20.5 lg)	0.91 (28.5)
50	0.75 (27.0)	1/2-20 X 0.77 lg (M18 x 1.5-26 lg)	1.08 (33.5)
63	0.75 (27.0)	1/2-20 X 0.77 lg (M18 x 1.5-26 lg)	1.08 (33.5)
80	0.93 (32.0)	5/8-18 X 1.0 lg (M22 x 1.5-32.5 lg)	1.40 (43.5)
100	1.13 (46.0)	3/4-16 X 1.12 lg (M26 x 1.5-32.5 lg)	1.59 (43.5)

BORE MM	O (THREADS) INCH (MM)	RF INCH (MM)
32	1/4-20 (M6 x 1.0)	0.67 (17.0)
40	1/4-20 (M6 x 1.0)	0.75 (19.0)
50	5/16-18 (M8 x 1.25)	0.75 (19.0)
63	7/16-14 (M10 x 1.5)	0.87 (22.0)
80	1/2-13 (M12 x 1.75)	1.13 (29.0)
100	1/2-13 (M12 x 1.75)	1.13 (29.0)

Dimensions measurements in millimeters and inches (in parenthesis)

BORE	M	ØN	ØO	*P	Q	R	ØS	T	W	Z
32 (1-1/4)	34.0 (1.34)	5.5 (0.22)	9.0 x 7.0dp (0.35 x 0.28 dp)	1/8*	8.7 (0.34)	41.1 (1.62)	38.0 (1.50)	7.6 (0.30)	49.3 (1.94)	21.4 (0.84)
40 (1-1/2)	40.0 (1.57)	5.5 (0.22)	9.0 x 7.0dp (0.35 x 0.28 dp)	1/8*	9.2 (0.36)	41.1 (1.62)	38.0 (1.50)	7.6 (0.30)	57.0 (2.24)	21.4 (0.84)
50 (2)	50.0 (1.97)	6.6 (0.26)	11.0 x 8.0dp (0.43 x 0.31 dp)	1/4*	10.5 (0.41)	53.6 (2.11)	50.8 (2.00)	12.0 (0.47)	70.6 (2.78)	26.5 (1.04)
63 (2-1/2)	60.0 (2.36)	9.0 (0.35)	14.0 x 10.5dp (0.55 x 0.41 dp)	1/4*	11.5 (0.45)	52.6 (2.07)	50.8 (2.00)	11.0 (0.43)	83.6 (3.29)	26.5 (1.04)
80 (3-1/4)	77.0 (3.03)	11.0 (0.43)	17.5 x 13.5dp (0.69 x 0.53 dp)	3/8*	14.0 (0.55)	56.6 (2.23)	50.8 (2.00)	15.0 (0.59)	104.0 (4.09)	30.0 (1.18)
100 (4)	94.0 (3.70)	11.0 (0.43)	17.5 x 13.5dp (0.69 x 0.53 dp)	3/8*	18.0 (0.71)	65.1 (2.56)	50.8 (2.00)	15.0 (0.59)	121.9 (4.80)	30.0 (1.18)

Universal Series  
Metric Compact Interchangeable

Rear Clevis Mount

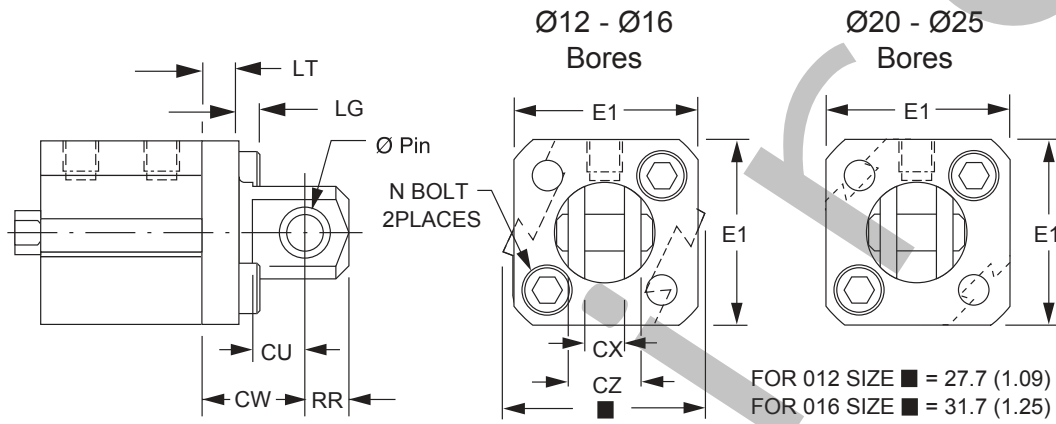

Ø32 - Ø100 Bores

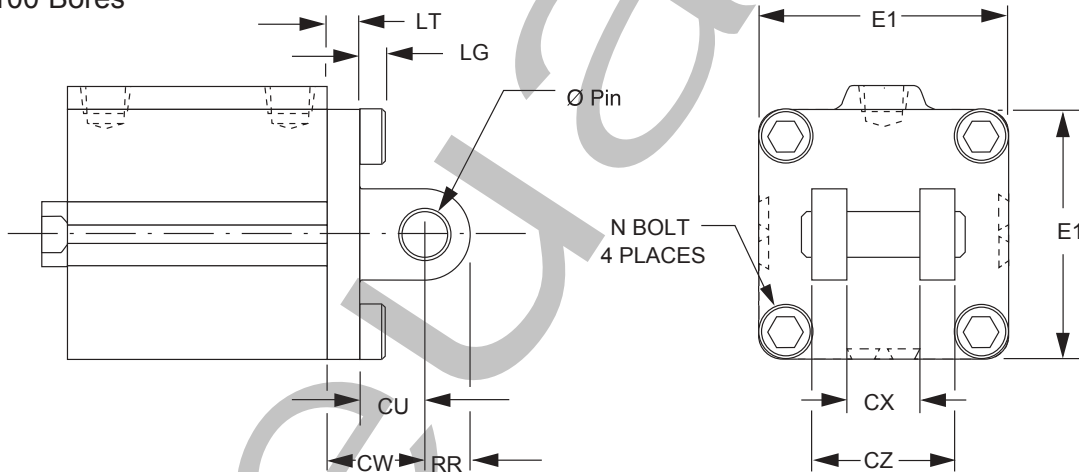

NOTE: All clevis mounts attach to cylinder body with metric size socket cap screws.

BORE MM	12	16	20	25	32	40	50	63	80	100
N Bolt	M4 x 0.7	M4 x 0.7	M6 x 1.0	M6 x 1.0	M6 x 1.0	M6 x 1.0	M8 x 1.25	M10 x 1.5	M12 x 1.75	M12 x 1.75

Dimensions measurements in millimeters and inches (in parenthesis)

BORE	Ø PIN NOMINAL MM (INCH)	CW	CU	CX	CZ	LT	LG	RR	E1
12 (1/2)	5.0 (0.19)	14.0 (0.55)	7.0 (0.28)	5.3 (0.21)	10.0 (0.39)	5.0 (0.20)	2.8 (0.11)	6.0 (0.24)	25.0 (0.98)
16 (5/8)	5.0 (0.19)	15.0 (0.59)	10.0 (0.39)	6.8 (0.27)	12.0 (0.47)	5.0 (0.20)	2.8 (0.11)	6.0 (0.24)	29.0 (1.14)
20 (3/4)	8.0 (0.319)	18.0 (0.71)	12.0 (0.47)	8.3 (0.33)	16.0 (0.63)	5.0 (0.20)	4.0 (0.16)	9.0 (0.35)	36.0 (1.42)
25 (1)	10.0 (0.36)	20.0 (0.79)	14.0 (0.55)	10.3 (0.41)	20.0 (0.79)	5.0 (0.20)	4.0 (0.16)	10.0 (0.39)	40.0 (1.57)
32 (1-1/4)	10.0 (0.36)	20.0 (0.79)	14.0 (0.55)	18.3 (0.72)	36.0 (1.42)	6.0 (0.24)	4.0 (0.16)	10.0 (0.39)	44.5 (1.75)
40 (1-1/2)	10.0 (0.36)	22.0 (0.87)	14.0 (0.55)	18.3 (0.72)	36.0 (1.42)	8.0 (0.31)	4.0 (0.16)	10.0 (0.39)	52.0 (2.05)
50 (2)	14.0 (0.50)	28.0 (1.10)	20.0 (0.79)	22.3 (0.88)	44.0 (1.73)	8.0 (0.31)	5.0 (0.20)	14.0 (0.55)	63.7 (2.51)
63 (2-1/2)	14.0 (0.50)	30.0 (1.18)	20.0 (0.79)	22.3 (0.88)	44.0 (1.73)	10.0 (0.39)	6.0 (0.24)	14.0 (0.55)	76.7 (3.02)
80 (3-1/4)	18.0 (0.75)	38.0 (1.50)	27.0 (1.07)	28.3 (1.11)	56.0 (2.20)	11.0 (0.43)	7.0 (0.28)	18.0 (0.71)	97.8 (3.85)
100 (4)	22.0 (0.88)	45.0 (1.77)	31.0 (1.22)	32.3 (1.27)	64.0 (2.52)	14.0 (0.55)	7.0 (0.28)	22.0 (0.87)	115.3 (4.54)



Foot Mounts

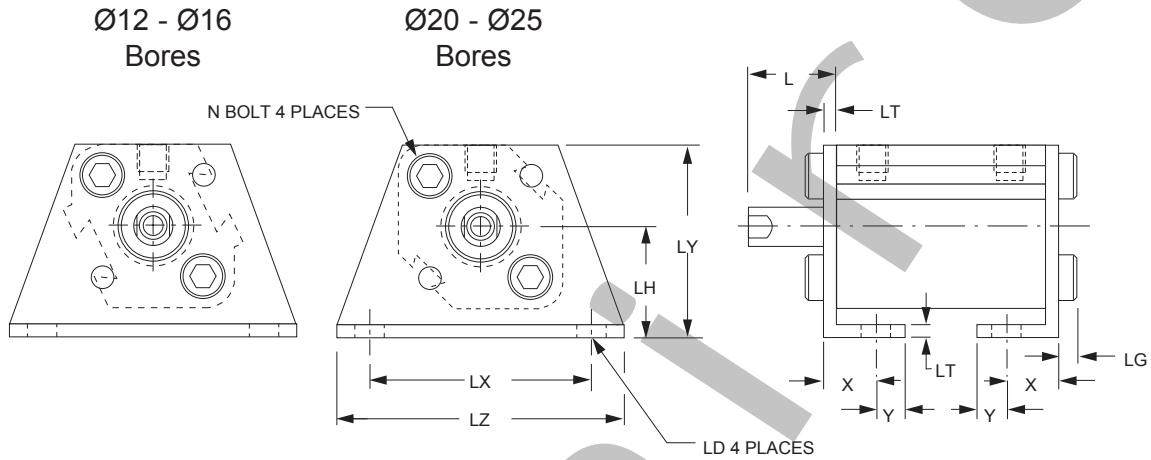

Ø32 - Ø100 Bores

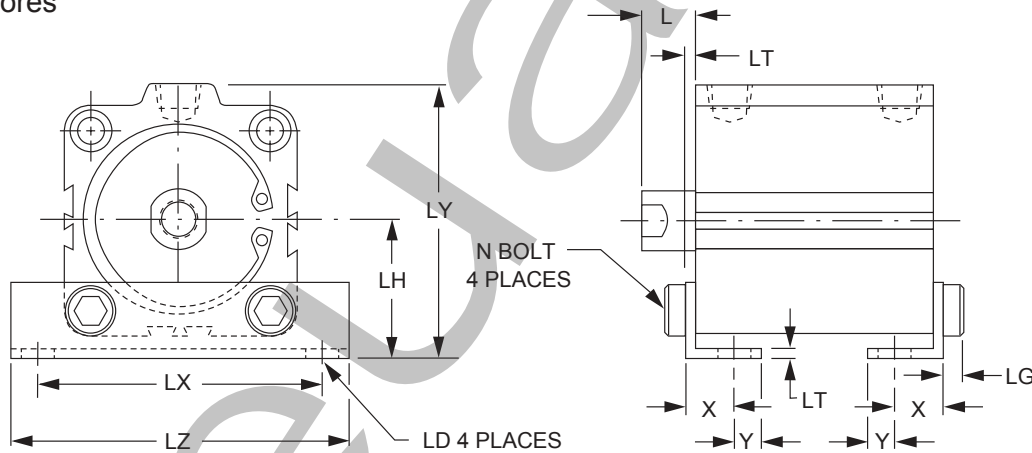

NOTE: All feet attach to cylinder body with metric size socket cap screws.

BORE MM	12	16	20	25	32	40	50	63	80	100
N Bolt	M4 x 0.7	M4 x 0.7	M6 x 1.0	M6 x 1.0	M6 x 1.0	M6 x 1.0	M8 x 1.25	M10 x 1.5	M12 x 1.75	M12 x 1.75

Dimensions measurements in millimeters and inches (in parenthesis)

BORE	LD	LH	LX	LY	LZ	L	LT	X	Y	LG
12 (1/2)	4.5 (0.18)	17.0 (0.67)	34.0 (1.39)	29.5 (1.16)	44.0 (1.73)	13.5 (0.53)	2.0 (0.08)	8.0 (0.31)	4.5 (0.18)	2.8 (0.11)
16 (5/8)	4.5 (0.18)	19.0 (0.75)	38.0 (1.50)	33.5 (1.32)	48.0 (1.89)	13.5 (0.53)	2.0 (0.08)	8.0 (0.31)	5.0 (0.20)	2.8 (0.11)
20 (3/4)	6.6 (0.26)	24.0 (0.94)	48.0 (1.89)	42.0 (1.65)	62.0 (2.44)	14.5 (0.57)	3.2 (0.13)	9.2 (0.36)	5.8 (0.23)	4.0 (0.16)
25 (1)	6.6 (0.26)	26.0 (1.02)	52 (2.05)	46.0 (1.81)	66.0 (2.60)	15.0 (0.59)	3.2 (0.13)	10.7 (0.42)	5.8 (0.23)	4.0 (0.16)
32 (1-1/4)	6.6 (0.26)	30.0 (1.18)	57.0 (2.24)	57.0 (2.24)	71.0 (2.80)	17.0 (0.67)	3.2 (0.13)	11.2 (0.44)	5.8 (0.23)	4.0 (0.16)
40 (1-1/2)	6.6 (0.26)	33.0 (1.30)	64.0 (2.52)	64.0 (2.52)	78.0 (3.07)	17.0 (0.67)	3.2 (0.13)	11.2 (0.44)	7.0 (0.28)	4.0 (0.16)
50 (2)	9.0 (0.35)	39.0 (1.54)	79.0 (3.11)	78.0 (3.07)	95.0 (3.74)	18.0 (0.71)	3.2 (0.13)	14.7 (0.58)	8.0 (0.31)	5.0 (0.20)
63 (2-1/2)	11.0 (0.43)	46.0 (1.81)	95.0 (3.74)	91.5 (3.60)	113.0 (4.45)	18.0 (0.71)	3.2 (0.13)	16.2 (0.64)	9.0 (0.35)	6.0 (0.24)
80 (3-1/4)	13.0 (0.51)	59.0 (2.32)	118.0 (4.65)	114.0 (4.49)	140.0 (5.51)	20.0 (0.79)	4.5 (0.18)	19.5 (0.77)	11.0 (0.43)	7.0 (0.28)
100 (4)	13.0 (0.51)	71.0 (2.80)	137.0 (5.39)	136.0 (5.35)	162.0 (6.38)	22.0 (0.87)	6.0 (0.24)	23.0 (0.91)	12.5 (0.49)	7.0 (0.28)

Universal Series  
Metric Compact Interchangeable

Flange Mounts

Front Flange

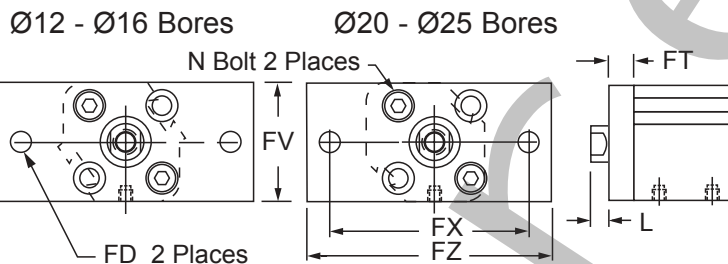

Rear Flange

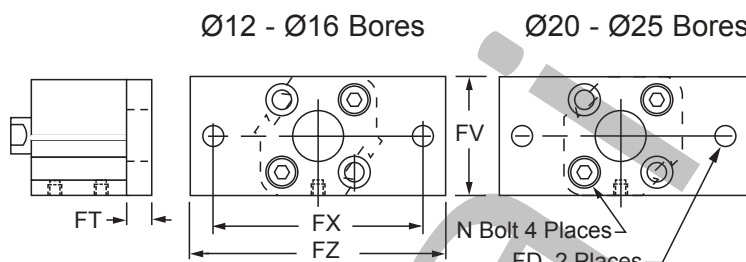

Front Flange - Ø32 - Ø100 Bores

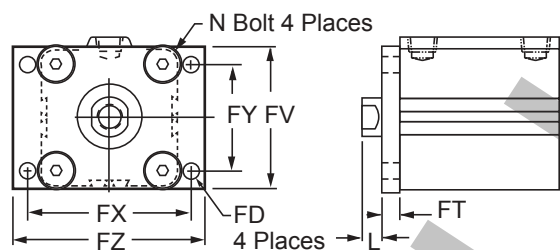

Rear Flange - Ø32 - Ø100 Bores

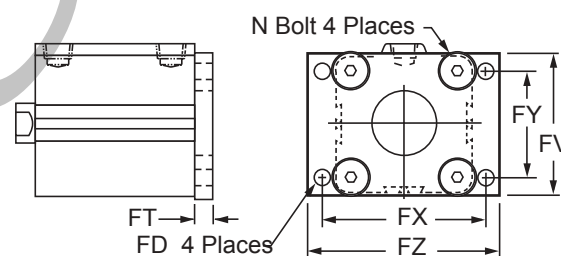

NOTE: All flanges attach to cylinder body with metric size flat head socket screws.

BORE	ISO RECTANGULAR FLANGE DIMENSIONS				
	FD	FY	FX	FV	FZ
12 (1/2)	5.5 (0.22)	-	40.0 (1.57)	25.0 (0.98)	50.0 (1.97)
16 (5/8)	5.5 (0.22)	-	40.0 (1.57)	30.0 (1.18)	50.0 (1.97)
20 (3/4)	6.6 (0.26)	-	50.0 (1.97)	39.0 (1.54)	62.0 (2.44)
25 (1)	6.6 (0.26)	-	50.0 (1.97)	42.0 (1.65)	62.0 (2.44)
32 (1-1/4)	7.0 (0.28)	32.0 (1.26)	64.0 (2.52)	48.0 (1.89)	76.0 (2.99)
40 (1-1/2)	9.0 (0.35)	36.0 (1.42)	72.0 (2.83)	54.0 (2.13)	88.0 (3.47)
50 (2)	9.0 (0.35)	45.0 (1.77)	90.0 (3.54)	67.0 (2.64)	106.0 (4.17)
63 (2-1/2)	9.0 (0.35)	50.0 (1.97)	100.0 (3.94)	80.0 (3.15)	116.0 (4.57)
80 (3-1/4)	12.0 (0.47)	63.0 (2.48)	126.0 (4.96)	99.0 (3.90)	150.0 (5.91)
100 (4)	14.0 (0.55)	75.0 (2.95)	150.0 (5.91)	117.0 (4.61)	178.0 (7.01)

Dimensions measurements in millimeters and inches (in parenthesis)

BORE	COMMON DIMENSIONS			INTERCHANGEABLE (NON-ISO) FLANGE DIMENSIONS				
	FT	L	N BOLT	FD	FY	FX	FV	FZ
12 (1/2)	5.5 (0.22)	8.0 (0.31)	M4 x 0.7	4.5 (0.18)	-	45.0 (1.77)	25.0 (0.98)	55.0 (2.17)
16 (5/8)	5.5 (0.22)	8.0 (0.31)	M4 x 0.7	4.5 (0.18)	-	45.0 (1.77)	30.0 (1.18)	55.0 (2.17)
20 (3/4)	8.0 (0.31)	6.5 (0.26)	M6 x 1.0	6.6 (0.26)	-	48.0 (1.89)	39.0 (1.54)	60.0 (2.36)
25 (1)	8.0 (0.31)	7.0 (0.28)	M6 x 1.0	6.6 (0.26)	-	52.0 (2.05)	42.0 (1.65)	64.0 (2.52)
32 (1-1/4)	8.0 (0.31)	9.0 (0.35)	M6 x 1.0	5.5 (0.22)	34.0 (1.34)	56.0 (2.20)	48.0 (1.89)	65.0 (2.56)
40 (1-1/2)	8.0 (0.31)	9.0 (0.35)	M6 x 1.0	5.5 (0.22)	40.0 (1.57)	62.0 (2.44)	54.0 (2.13)	72.0 (2.83)
50 (2)	9.0 (0.35)	9.0 (0.35)	M8 x 1.25	6.6 (0.26)	50.0 (1.97)	76.0 (2.99)	67.0 (2.64)	89.0 (3.50)
63 (2-1/2)	9.0 (0.35)	9.0 (0.35)	M10 x 1.5	9.0 (0.35)	60.0 (2.36)	92.0 (3.62)	80.0 (3.15)	108.0 (4.25)
80 (3-1/4)	11.0 (0.43)	9.0 (0.35)	M12 x 1.75	11.0 (0.43)	77.0 (3.03)	116.0 (4.57)	99.0 (3.90)	134.0 (5.28)
100 (4)	11.0 (0.43)	11.0 (0.43)	M12 x 1.75	11.0 (0.43)	94.0 (3.70)	136.0 (5.35)	117.0 (4.61)	154.0 (6.06)



Universal Series  
Metric Compact Interchangeable



Front and Rear Boss Mounts

Front Boss - Ø12 - Ø16 Bores

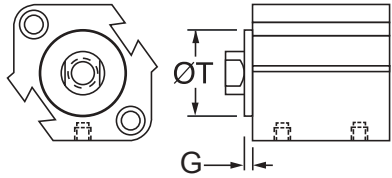

Rear Boss - Ø12 - Ø16 Bores

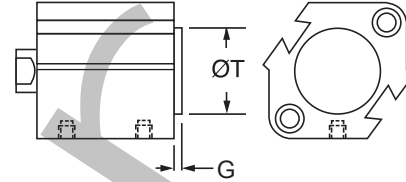

Front Boss - Ø20 - Ø25 Bores

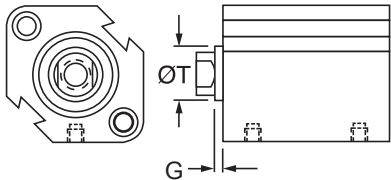

Rear Boss - Ø20 - Ø25 Bores

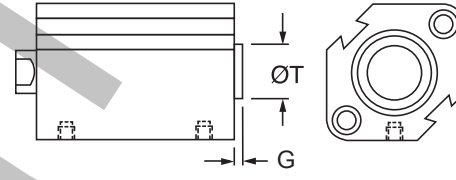

Front Boss - Ø20 - Ø25 Bores

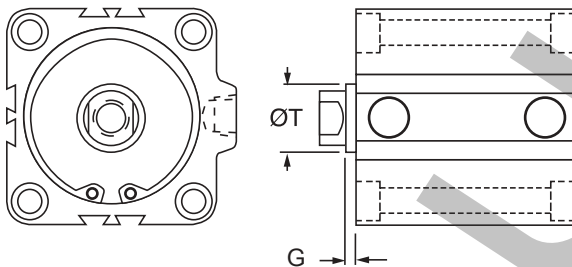

Rear Boss - Ø20 - Ø25 Bores

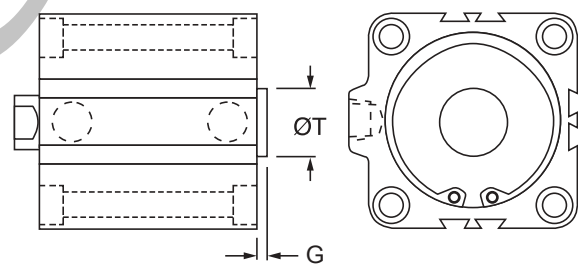

Dimensions measurements in millimeters and inches (in parenthesis)

BORE	ØT	G
12 (1/2)	15 +0/-0.043 (0.591 +0/-0.002)	1.5 (0.06)
16 (5/8)	20 +0/-0.052 (0.787 +0/-0.002)	1.5 (0.06)
20 (3/4)	13 +0/-0.043 (0.512 +0/-0.002)	2.0 (0.08)
25 (1)	15 +0/-0.043 (0.591 +0/-0.002)	2.0 (0.08)
32 (1-1/4)	21 +0/-0.062 (0.827 +0/-0.002)	2.0 (0.08)
40 (1-1/2)	28 +0/-0.062 (1.102 +0/-0.002)	2.0 (0.08)
50 (2)	35 +0/-0.062 (1.378 +0/-0.002)	2.0 (0.08)
63 (2-1/2)	35 +0/-0.062 (1.378 +0/-0.002)	2.0 (0.08)
80 (3-1/4)	43 +0/-0.062 (1.693 +0/-0.002)	2.0 (0.08)
100 (4)	59 +0/-0.074 (2.323 +0/-0.003)	2.0 (0.08)



Universal Series  
Metric Compact Interchangeable



Accessories

Rod Eye

To order a Rod Eye use the Prefix UE– followed by the thread size.

Example: For a 25mm bore cylinder the inch rod threads are 1/4-28. The Rod Eye Part Number is UE-1/4-28

For #8-32 size, follow with -12 or -16 for bore. Example: UE-8-32-16

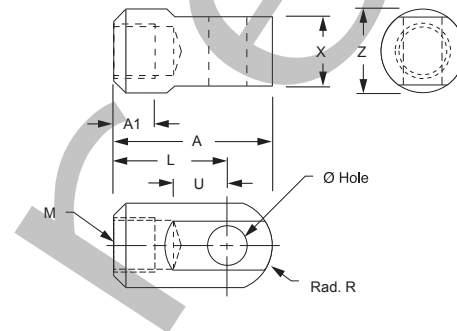

NOTE: Hole diameter will be inch size for items with inch thread and mm sizes for items with metric thread.

BORE	L	U	X	Z	A1	A	R
12 (1/2)	16.0 (0.63)	7.0 (0.27)	4.7 (0.18)	9.7 (0.38)	6.0 (0.24)	21.5 (0.85)	6.3 (0.25)
16 (5/8)	25.0 (0.98)	14.0 (0.55)	6.2 (0.24)	11.2 (0.44)	6.0 (0.24)	32.0 (1.26)	12.0 (0.47)
20 (3/4)	25.0 (0.98)	11.5 (0.45)	7.7 (0.30)	16.0 (0.63)	6.0 (0.24)	34.0 (1.34)	10.3 (0.41)
25 (1)	30.0 (1.18)	14.0 (0.55)	9.7 (0.38)	19.0 (0.75)	8.0 (0.31)	41.0 (1.61)	12.8 (0.50)
32 (1-1/4)	30.0 (1.18)	14.0 (0.55)	17.6 (0.69)	22.0 (0.87)	14.0 (0.55)	42.0 (1.65)	12.0 (0.47)
40 (1-1/2)	30.0 (1.18)	14.0 (0.55)	17.6 (0.69)	22.0 (0.87)	14.0 (0.55)	42.0 (1.65)	12.0 (0.47)
50 (2)	40.0 (1.57)	20.0 (0.79)	21.6 (0.85)	27.0 (1.06)	18.0 (0.71)	56.0 (2.20)	16.0 (0.63)
63 (2-1/2)	40.0 (1.57)	20.0 (0.79)	21.6 (0.85)	27.0 (1.06)	18.0 (0.71)	56.0 (2.20)	16.0 (0.63)
80 (3-1/4)	50.0 (1.97)	27.0 (1.06)	27.6 (1.08)	38.0 (1.50)	21.0 (0.83)	71.0 (2.80)	21.0 (0.83)
100 (4)	55.0 (2.17)	31.0 (1.22)	31.6 (1.24)	44.5 (1.75)	21.0 (0.83)	79.0 (3.11)	24.0 (0.95)

Rod Clevis

To order a Rod Clevis use the Prefix UC– followed by the thread size. Example:

For a 63mm bore cylinder the metric threads are M18 x 1.5. The Rod Clevis Part Number is UC-M18x1.5

For #8-32 size, follow with -12 or -16 for bore.

Example: UC-8-32-12

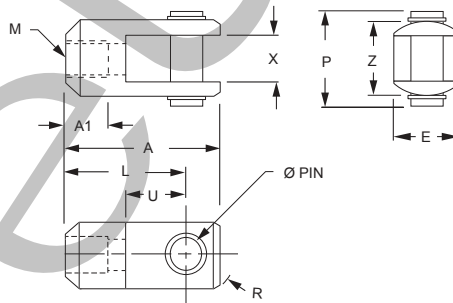

NOTE: Pin diameter will be inch size for items with inch thread and mm sizes for items with metric thread.

BORE MM	Ø HOLE, Ø PIN INCH (MM)	M (THREADS) INCH (MM)
12	0.19 (5.0)	#8-32 (M5 x 0.8)
16	0.19 (5.0)	#8-32 (M6 x 1.0)
20	0.31 (8.0)	#10-32 (M8 x 1.25)
25	0.38 (10.0)	1/4-28 (M10 x 1.25)
32	0.38 (10.0)	5/16-24 (M14 x 1.5)
40	0.38 (10.0)	3/8-24 (M14 x 1.5)
50	0.50 (14.0)	1/2-20 (M18 x 1.5)
63	0.50 (14.0)	1/2-20 (M18 x 1.5)
80	0.75 (18.0)	5/8-18 (M22 x 1.5)
100	0.88 (22.0)	3/4-16 (M26 x 1.5)

BORE	L	U	X	Z	P	E	A1	A	R
12 (1/2)	16.0 (0.63)	7.0 (0.27)	5.3 (0.21)	10.0 (0.39)	14.0 (0.55)	10.0 (0.39)	6.0 (0.24)	21.5 (0.85)	6.3 (0.25)
16 (5/8)	21.0 (0.83)	10.0 (0.39)	6.6 (0.26)	12.0 (0.47)	16.0 (0.63)	12.0 (0.47)	6.0 (0.24)	28.0 (1.10)	12.0 (0.47)
20 (3/4)	25.0 (0.98)	11.5 (0.45)	8.3 (0.33)	16.0 (0.63)	21.0 (0.83)	16.0 (0.63)	6.0 (0.24)	34.0 (1.34)	10.3 (0.41)
25 (1)	30.0 (1.18)	14.0 (0.55)	10.3 (0.41)	20.0 (0.78)	25.0 (0.98)	20.0 (0.78)	8.0 (0.31)	41.0 (1.61)	12.8 (0.50)
32 (1-1/4)	30.0 (1.18)	14.0 (0.55)	18.4 (0.72)	36.6 (1.44)	41.0 (1.61)	22.0 (0.87)	16.0 (0.63)	42.0 (1.65)	12.0 (0.47)
40 (1-1/2)	30.0 (1.18)	14.0 (0.55)	18.4 (0.72)	36.6 (1.44)	41.0 (1.61)	22.0 (0.87)	16.0 (0.63)	42.0 (1.65)	12.0 (0.47)
50 (2)	40.0 (1.57)	20.0 (0.79)	22.4 (0.88)	44.5 (1.75)	50.0 (1.97)	28.0 (1.10)	20.0 (0.79)	56.0 (2.20)	16.0 (0.63)
63 (2-1/2)	40.0 (1.57)	20.0 (0.79)	22.4 (0.88)	44.5 (1.75)	50.0 (1.97)	28.0 (1.10)	20.0 (0.79)	56.0 (2.20)	16.0 (0.63)
80 (3-1/4)	50.0 (1.97)	27.0 (1.06)	28.4 (1.12)	55.6 (2.19)	62.5 (2.46)	38.0 (1.50)	23.0 (0.91)	71.0 (2.80)	21.0 (0.83)
100 (4)	55.0 (2.17)	31.0 (1.22)	32.4 (1.28)	63.5 (2.50)	70.6 (2.78)	44.0 (1.73)	24.0 (0.95)	79.0 (3.11)	24.0 (0.95)



## Universal Series Metric Compact Interchangeable



The Universal Series with Guide Plate is a robust compact non-rotating (guided), extruded aluminum body air cylinder line. The Universal Series with Guide Plate is a double-acting cylinder that provides the solution to specific applications where piston rod rotation is not acceptable.

### Standard Specifications:

- Bore sizes from 12 mm through 160 mm
- Strokes from 5 mm to 300 mm
- Nominal pressure rating is 10 bar (150 psi)
- 3 tooling plate choices:
  - ▼ Blank
  - ▼ Metric
  - ▼ Inch
- Flexible porting options:
  - ▼ NPT ports and inch mounting holes in tooling plate and cylinder
  - ▼ BSP Parallel ports and metric mounting holes in tooling plate and cylinder
  - ▼ BSPT taper ports and metric mounting holes in tooling and cylinder
- Chrome plated, stainless steel guide shafts with high performance composite linear bearings
- 4 tapped holes on the tooling plate
- 2 counter bored clearance holes on all tooling plates except 12 mm bore
- Rear mounting:
  - ▼ 12 mm bore
    - 2 holes tapped at rear
  - ▼ 16 - 25 mm bores
    - 2 holes counter bored and tapped at rear
  - ▼ 32 - 100 mm bores
    - 2 through clearance holes, counter bored each end, tapped each end
- 125 - 160 mm bores
  - ▼ 2 additional holes counter bored and tapped at rear
- Magnetic piston option
- Bumper option
- Seal material deviation

### Ø12 - Ø25 mm Bores

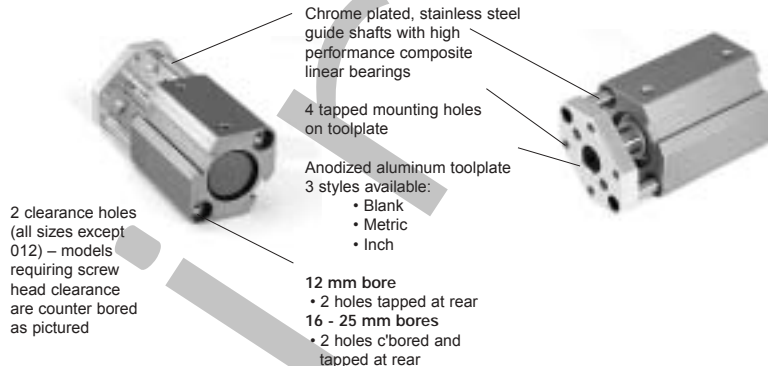

### Ø32 - Ø160 mm Bores

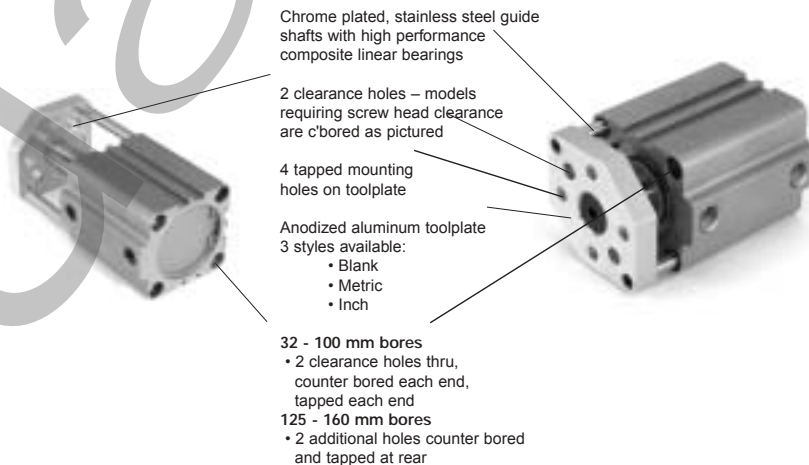

## How to Order

**UT G D - 032 - 005 - B**

### Series

UT = Universal Series with Guide Plate

### Port

- G = BSP Parallel Ports, Metric Mounting Holes in Toolplate and Cylinder
- N = NPT Ports, Inch Mounting Holes in Toolplate and Cylinder
- P = BSPT Taper Ports, Metric Mounting Holes in Toolplate and Cylinder

### Body

- D = With Magnetic Piston
- N = Without Magnetic Piston<sup>34</sup>

### Options

- B = Bumpers
- V = High Temperature Seals
- T1 = Blank Toolplate

### Stroke

- 005 = 5 mm
- 010 = 10 mm
- 100 = 100 mm
- 150 = 150 mm
- 300 = 300 mm

### Bore

- 012 = 12 mm
- 016 = 16 mm
- 020 = 20 mm
- 025 = 25 mm
- 032 = 32 mm
- 040 = 40 mm
- 050 = 50 mm
- 063 = 63 mm
- 080 = 80 mm
- 100 = 100 mm
- 125 = 125 mm
- 140 = 140 mm
- 160 = 160 mm



Universal Series  
Metric Compact Interchangeable



Engineering Data

Maximum Allowable Load to Toolplate - Kg. (lbs.)

Dimensions measurements in millimeters and inches (in parenthesis)

BORE	STANDARD AVAILABLE CYLINDER STROKES MM (INCH)									
	5.0 (0.20)	10.0 (0.39)	15.0 (0.59)	20.0 (0.79)	25.0 (0.98)	30.0 (1.18)	35.0 (1.38)	40.0 (1.57)	45.0 (1.77)	
12 (1/2)	3.54 (7.8)	2.72 (6.0)	1.36 (3.0)	1.14 (2.5)	0.95 (2.1)	0.86 (1.9)	-	-	-	
16 (5/8)	4.99 (11.0)	4.09 (9.0)	2.13 (4.7)	1.86 (4.1)	1.54 (3.4)	1.32 (2.9)	-	-	-	
20 (3/4)	7.72 (17.0)	7.26 (16.0)	4.99 (11.0)	4.09 (9.0)	3.18 (7.0)	2.81 (6.2)	2.59 (5.7)	2.36 (5.2)	2.27 (5.0)	
25 (1)	8.17 (18.0)	7.49 (16.5)	5.45 (12.0)	4.77 (10.5)	4.09 (9.0)	3.41 (7.5)	2.72 (6.0)	2.50 (5.5)	2.36 (5.2)	
32 (1-1/4)	10.90 (24.0)	9.08 (20.0)	7.04 (15.5)	6.13 (13.5)	4.99 (11.0)	4.54 (10.0)	3.63 (8.0)	3.41 (7.5)	3.27 (7.2)	
40 (1-1/2)	11.80 (26.0)	9.99 (22.0)	7.72 (17.0)	6.45 (14.2)	5.31 (11.7)	4.81 (10.6)	3.90 (8.6)	3.68 (8.1)	3.54 (7.8)	
50 (2)	-	15.66 (34.5)	14.07 (31.0)	12.71 (28.0)	11.35 (25.0)	10.44 (23.0)	9.99 (22.0)	8.63 (19.0)	7.26 (16.0)	
63 (2-1/2)	-	25.42 (56.0)	22.70 (50.0)	21.11 (46.5)	17.25 (38.0)	14.98 (33.0)	13.17 (29.0)	10.44 (23.0)	8.85 (19.5)	
80 (3-1/4)	-	38.59 (85.0)	35.82 (78.9)	33.14 (73.0)	30.87 (68.0)	28.60 (63.0)	26.79 (59.0)	20.43 (45.0)	16.80 (37.0)	
100 (4)	-	42.00 (92.5)	38.59 (85.0)	35.87 (79.0)	33.60 (74.0)	31.33 (69.0)	29.51 (65.0)	22.25 (49.0)	17.71 (39.0)	
125 (4.9)	-	44.95 (99.0)	-	38.59 (85.0)	-	34.05 (75.0)	-	24.06 (53.0)	-	
140 (5-1/2)	-	48.58 (107.0)	-	42.22 (93.0)	-	36.77 (81.0)	-	25.88 (57.0)	-	
160 (6-1/4)	-	76.27 (168.0)	-	66.28 (146.0)	-	57.66 (127.0)	-	42.22 (93.0)	-	

BORE	STANDARD AVAILABLE CYLINDER STROKES MM (INCH)									
	50.0 (1.97)	75.0 (2.95)	100.0 (3.94)	125.0 (4.92)	150.0 (5.91)	175.0 (6.89)	200.0 (7.87)	250.0 (9.84)	300.0 (11.81)	
12 (1/2)	0.50 (1.1)	0.41 (0.9)	0.32 (0.7)	-	-	-	-	-	-	
16 (5/8)	0.77 (1.7)	0.64 (1.4)	0.41 (0.9)	-	-	-	-	-	-	
20 (3/4)	2.09 (4.6)	1.23 (2.7)	0.77 (1.7)	-	-	-	-	-	-	
25 (1)	2.18 (4.8)	1.32 (2.9)	0.86 (1.9)	-	-	-	-	-	-	
32 (1-1/4)	3.04 (6.7)	2.45 (5.4)	1.91 (4.2)	0.73 (1.6)	0.41 (0.9)	-	-	-	-	
40 (1-1/2)	3.22 (7.1)	2.63 (5.8)	2.09 (4.6)	0.86 (1.9)	0.54 (1.2)	-	-	-	-	
50 (2)	5.90 (13.0)	4.81 (10.6)	4.13 (9.1)	1.36 (3.0)	1.04 (2.3)	-	-	-	-	
63 (2-1/2)	8.40 (18.5)	6.63 (14.6)	5.49 (12.1)	2.04 (4.5)	1.41 (3.1)	-	-	-	-	
80 (3-1/4)	14.98 (33.0)	12.08 (26.6)	10.26 (22.6)	3.81 (8.4)	2.63 (5.8)	-	-	-	-	
100 (4)	15.89 (35.0)	13.17 (29.0)	11.17 (24.6)	4.13 (9.1)	2.86 (6.3)	-	-	-	-	
125 (4.9)	16.80 (37.0)	14.07 (31.0)	11.80 (26.0)	5.45 (12.0)	4.31 (9.5)	3.31 (7.3)	2.50 (5.5)	1.68 (3.7)	1.23 (2.7)	
140 (5-1/2)	19.98 (44.0)	19.07 (42.0)	15.89 (35.0)	7.26 (16.0)	5.90 (13.0)	4.31 (9.5)	3.45 (7.6)	2.63 (5.8)	2.04 (4.5)	
160 (6-1/4)	32.69 (72.0)	31.33 (69.0)	25.89 (57.0)	11.80 (26.0)	9.53 (21.0)	6.95 (15.3)	5.54 (12.2)	5.13 (11.3)	4.59 (10.1)	





Universal Series  
Metric Compact Interchangeable



“UT” Series, Guided Toolplate

Ø12 - Ø25 mm Bores

Standard Toolplate

Inch threads will be provided when 'N' port code is specified.

Metric threads will be provided when 'G' or 'P' port code is specified.

Blank Toolplate

Use Option Code T1 to specify a blank toolplate shown below.

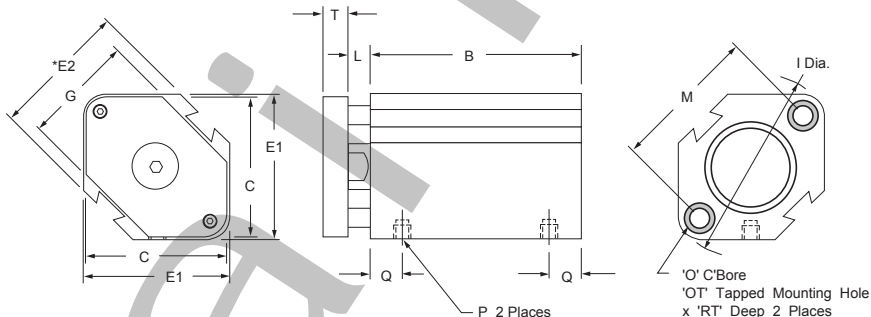
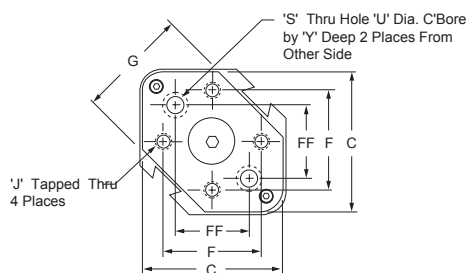

\*NOTE: See page 16 for additional cylinder body angle and profile dimensions.

Toolplate and Mounting - inch (mm)

Inch Dimensions Specified by Port Code 'N'

Metric Dimensions Specified by Port Code 'G' or 'P'

BORE mm	C	F	FF	G	J	OT	RT	S	U	Y
12	0.94 (24.0)	0.63 (16.0)	-	0.82 (20.8)	6-32 (M3 x 0.5)	8-32 (M4 x 0.7)	0.38 (9.7)	-	-	-
16	1.10 (28.0)	0.81 (20.0)	0.44 (11.0)	0.98 (25.0)	6-32 (M4 x 0.7)	8-32 (M4 x 0.7)	0.51 (13.0)	0.14 (3.3)	-	-
20	1.38 (35.0)	1.06 (27.0)	0.57 (14.5)	1.00 (25.4)	8-32 (M4 x 0.7)	1/4-20 (M6 x 1.0)	0.53 (13.5)	0.17 (4.2)	0.28	0.06
25	1.54 (40.0)	1.13 (28.5)	0.66 (16.6)	1.18 (30.0)	8-32 (M4 x 0.7)	1/4-20 (M6 x 1.0)	0.59 (15.0)	0.17 (4.2)	-	-

'Q' Port Location by Bore and Stroke

BORE mm	STROKE mm			
	5-45	50	75	100
12	7.0 (0.28)	8.9 (0.35)	8.9 (0.35)	8.9 (0.35)
16	7.8 (0.31)	10.2 (0.40)	10.2 (0.40)	10.2 (0.40)
20	8.1 (0.32)	8.1 (0.32)	12.1 (0.48)	12.1 (0.48)
25	8.4 (0.33)	8.4 (0.33)	12.7 (0.50)	12.7 (0.50)

'B' Dimensions by Bore and Stroke for both Standard and Magnetic Piston

measurements in millimeters and inches (in parenthesis)

BORE mm	STROKE mm											
	5	10	15	20	25	30	35	40	45	50	75	100
12	33.0 (1.30)	38.0 (1.50)	43.0 (1.69)	48.0 (1.89)	53.0 (2.07)	58.0 (2.28)	-	-	-	83.8 (3.30)	108.8 (4.28)	133.8 (5.27)
16	35.5 (1.40)	40.5 (1.59)	45.5 (1.79)	50.5 (1.99)	55.5 (2.19)	60.5 (2.38)	-	-	-	86.2 (3.39)	111.2 (4.38)	136.2 (5.36)
20	36.5 (1.44)	41.5 (1.63)	46.5 (1.83)	51.5 (2.03)	56.5 (2.22)	61.5 (2.42)	66.5 (2.62)	71.5 (2.81)	76.5 (3.01)	81.5 (3.21)	116.6 (4.59)	141.6 (5.57)
25	37.5 (1.48)	42.5 (1.67)	47.5 (1.87)	52.5 (2.07)	57.5 (2.26)	62.5 (2.46)	67.5 (2.66)	72.5 (2.85)	77.5 (3.05)	82.5 (3.25)	122.5 (4.82)	147.5 (5.81)

Dimensions measurements in millimeters and inches (in parenthesis)

BORE mm	E1	E2	I	L	M	O	P	T
12	25.0 (0.98)	23.0 (0.90)	31.5 (1.24)	3.5 (0.14)	22.0 (0.87)	-	M5 x 0.8	6.1 (0.24)
16	29.0 (1.14)	27.2 (1.07)	37.1 (1.46)	3.5 (0.14)	28.0 (1.10)	6.5 x 3.5 dp (0.26 x 0.14 dp)	M5 x 0.8	6.1 (0.24)
20	36.0 (1.42)	31.2 (1.23)	47.0 (1.85)	4.5 (0.18)	36.0 (1.42)	9.0 x 7.0 dp (0.35 x 0.28 dp)	M5 x 0.8	6.9 (0.27)
25	40.0 (1.57)	36.9 (1.45)	51.3 (2.02)	5.0 (0.20)	40.0 (1.57)	9.0 x 7.0 dp (0.35 x 0.28 dp)	M5 x 0.8	8.3 (0.33)



Universal Series  
Metric Compact Interchangeable

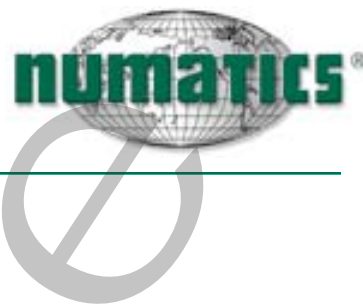

“UT” Series, Guided Toolplate  
Ø32 - Ø160 mm Bores

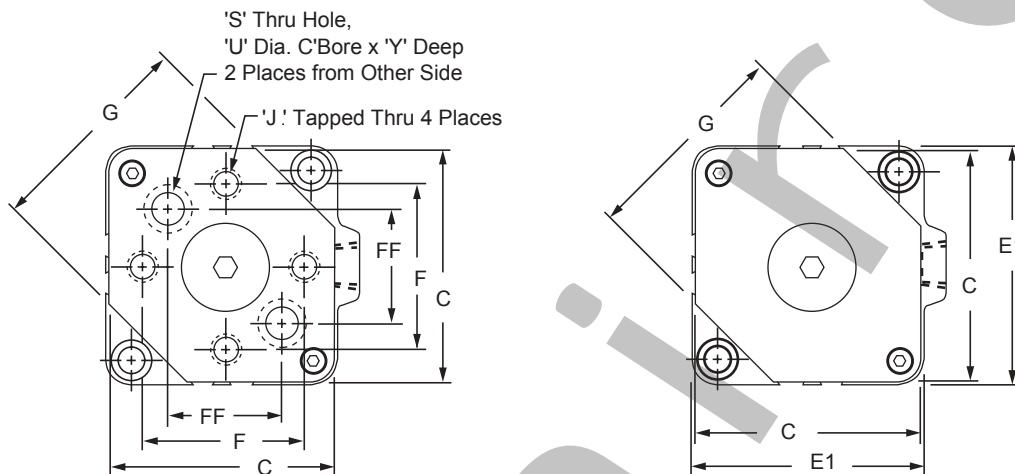

**Standard Toolplate**

Inch threads will be provided when 'N' port code is specified.  
Metric threads will be provided when 'G' or 'P' port code is specified.

**Blank Toolplate**

Use Option Code T1 to specify a blank toolplate shown above.

**Toolplate and Mounting - inch (mm)**

Inch Dimensions Specified by Port Code 'N'  
Metric Dimensions Specified by Port Code 'G' or 'P'

BORE mm	C	F	FF	G	J	OT	RT	S	U	Y
32	1.71 (43.4)	1.19 (30.0)	0.84 (21.2)	1.44 (36.7)	10-24 (M5 x 0.8)	1/4-20 (M6 x 1.0)	0.67 (17.0)	0.20 (5.2)	-	-
40	2.00 (50.5)	1.38 (35.0)	0.97 (24.7)	1.78 (45.1)	1/4-20 (M6 x 1.0)	1/4-20 (M6 x 1.0)	0.75 (19.0)	0.26 (6.1)	-	-
50	2.47 (62.7)	1.75 (45.5)	1.24 (32.2)	2.25 (57.1)	5/16-18 (M8 x 1.25)	5/16-18 (M8 x 1.25)	0.75 (19.0)	0.33 (8.2)	0.49 (13.5)	0.10 (2.5)
63	2.98 (75.7)	2.00 (75.7)	1.41 (35.7)	2.69 (68.3)	7/16-14 (M10 x 1.5)	7/16-14 (M10 x 1.5)	0.87 (22.0)	0.45 (11.5)	0.68 (16.5)	0.18 (3.3)
80	3.81 (96.9)	2.75 (70.0)	1.95 (58.3)	3.50 (88.9)	1/2-13 (M12 x 1.75)	1/2-13 (M12 x 1.75)	1.13 (29.0)	0.52 (12.3)	0.77 (18.5)	0.18 (3.8)
100	4.50 (114.4)	3.25 (82.5)	2.30 (58.3)	4.45 (112.9)	1/2-13 (M12 x 1.75)	1/2-13 (M12 x 1.75)	1.13 (29.0)	0.52 (12.3)	0.77 (18.5)	0.13 (3.2)
125*	(141.0)	(95.0)	(67.2)	(134.7)	(M14 x 2.0)	(M14 x 2.0)	(40.0)	(14.3)	-	-
140*	(157.0)	(101.5)	(71.8)	(154.5)	(M14 x 2.0)	(M14 x 2.0)	(40.0)	(14.3)	-	-
160*	(175.5)	(120.5)	(85.2)	(174.1)	(M16 x 2.0)	(M16 x 2.0)	(45.2)	(16.7)	-	-

**"B" Dimension by Bore and Stroke**

\*These bore sizes only Code 'N' indicates NPT ports and metric toolplate dimensions

BORE mm	STROKE mm									
	5	10	15	20	25	30	35	40	45	
32	Std. Piston	28.0 (1.10)	33.0 (1.30)	38.0 (1.50)	43.0 (1.69)	48.0 (1.89)	53.0 (2.09)	58.0 (2.28)	63.0 (2.48)	68.0 (2.68)
	Mag. Piston	38.0 (1.50)	43.0 (1.69)	48.0 (1.89)	53.0 (2.09)	58.0 (2.28)	63.0 (2.48)	68.0 (2.68)	73.0 (2.87)	78.0 (3.07)
40	Std. Piston	34.5 (1.36)	39.5 (1.56)	44.5 (1.75)	49.5 (1.95)	54.5 (2.15)	59.5 (2.34)	64.5 (2.54)	69.5 (2.74)	74.5 (2.93)
	Mag. Piston	44.5 (1.75)	49.5 (1.95)	54.5 (2.15)	59.5 (2.34)	64.5 (2.54)	69.5 (2.74)	74.5 (2.93)	79.5 (3.13)	84.5 (3.33)
50	Std. Piston	-	40.5 (1.59)	45.5 (1.79)	50.5 (1.99)	55.5 (2.19)	60.5 (2.38)	65.5 (2.58)	70.5 (2.78)	75.5 (2.97)
	Mag. Piston	-	50.5 (1.99)	55.5 (2.19)	60.5 (2.38)	65.5 (2.58)	70.5 (2.78)	75.5 (2.97)	80.5 (3.17)	85.5 (3.37)
63	Std. Piston	-	46.0 (1.81)	51.0 (2.01)	56.0 (2.20)	61.0 (2.40)	66.0 (2.60)	71.0 (2.80)	76.0 (2.99)	81.0 (3.19)
	Mag. Piston	-	56.0 (2.20)	61.0 (2.40)	66.0 (2.60)	71.0 (2.80)	76.0 (2.99)	81.0 (3.19)	86.0 (3.39)	91.0 (3.58)
80	Std. Piston	-	53.5 (2.11)	58.5 (2.30)	63.5 (2.50)	68.5 (2.70)	73.5 (2.89)	78.5 (3.09)	83.5 (3.29)	88.5 (3.48)
	Mag. Piston	-	63.5 (2.50)	68.5 (2.70)	73.5 (2.89)	78.5 (3.09)	83.5 (3.29)	88.5 (3.48)	93.5 (3.68)	98.5 (3.88)
100	Std. Piston	-	63.0 (2.48)	68.0 (2.68)	73.0 (2.87)	78.0 (3.07)	83.0 (3.27)	88.0 (3.46)	93.0 (3.66)	98.0 (3.86)
	Mag. Piston	-	73.0 (2.87)	78.0 (3.07)	83.0 (3.27)	88.0 (3.46)	93.0 (3.66)	98.0 (3.86)	103.0 (4.06)	108.0 (4.25)
125	Std. & Mag.	-	93.0 (3.66)	-	103.0 (4.06)	-	113.0 (4.45)	-	123.0 (4.84)	-
140	Std. & Mag.	-	93.0 (3.66)	-	103.0 (4.06)	-	113.0 (4.45)	-	123.0 (4.84)	-
160	Std. & Mag.	-	101.0 (3.98)	-	111.0 (4.37)	-	121.0 (4.76)	-	131.0 (5.16)	-



Universal Series  
Metric Compact Interchangeable



“UT” Series, Guided Toolplate continued

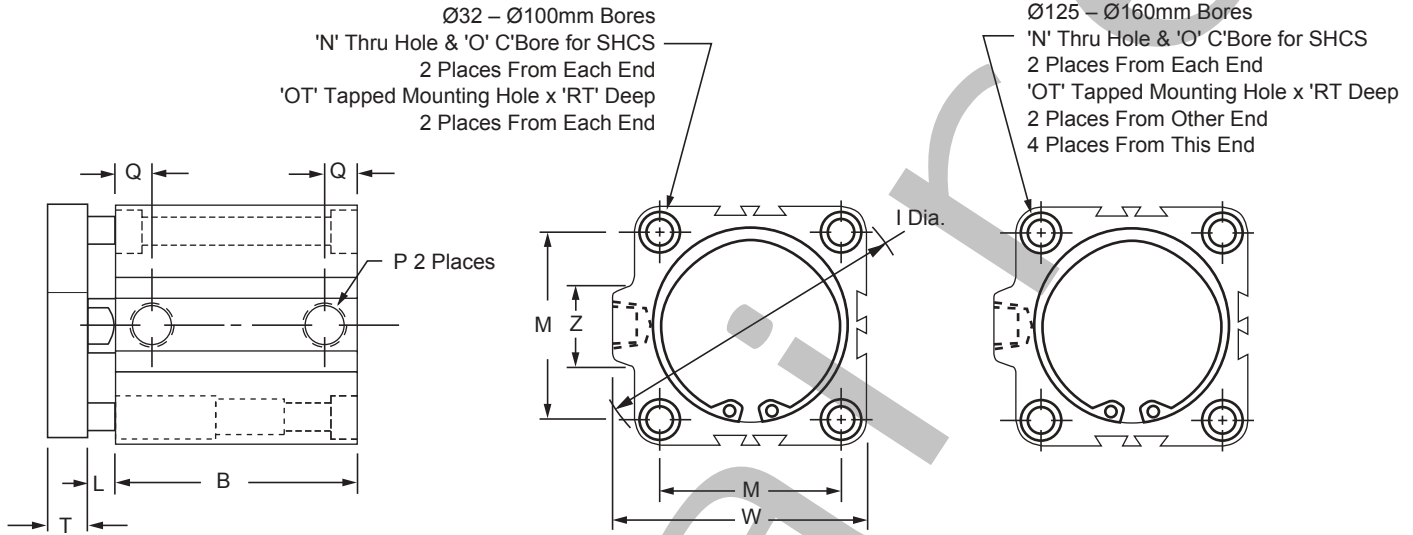

Dimensions measurements in millimeters and inches (in parenthesis)

BORE mm	E1	I	L	M	N	O	P	T	W	Z
32	44.5 (1.75)	58.9 (2.32)	7.0 (0.28)	34.0 (1.34)	5.5 (0.22)	9.0 x 7.0 dp (0.35 x 0.28 dp)	1/8*	8.3 (0.33)	49.3 (1.94)	21.4 (0.84)
40	52.0 (2.05)	69.0 (2.72)	7.0 (0.28)	40.0 (1.57)	5.5 (0.22)	9.0 x 7.0 dp (0.35 x 0.28 dp)	1/8*	8.3 (0.33)	57.0 (2.24)	21.4 (0.84)
50	63.7 (2.51)	84.5 (3.34)	8.0 (0.31)	50.0 (1.97)	6.6 (0.26)	11.0 x 8.0 dp (0.43 x 0.31 dp)	1/4*	12.1 (0.48)	70.6 (2.78)	26.5 (1.04)
63	76.7 (3.02)	101.8 (4.01)	8.0 (0.31)	60.0 (2.36)	9.0 (0.35)	14.0 x 10.5 dp (0.55 x 0.41 dp)	1/4*	12.5 (0.49)	83.6 (3.29)	26.5 (1.04)
80	97.8 (3.85)	129.8 (5.11)	10.0 (0.39)	77.0 (3.03)	11.0 (0.43)	17.5 x 13.5 dp (0.69 x 0.53 dp)	3/8*	14.0 (0.55)	104.0 (4.09)	30.0 (1.18)
100	115.3 (4.54)	153.9 (6.06)	12.0 (0.47)	94.0 (3.70)	11.0 (0.43)	17.5 x 13.5 dp (0.69 x 0.53 dp)	3/8*	14.0 (0.55)	121.9 (4.80)	30.0 (1.18)
125	142.0 (5.59)	190.0 (7.48)	16.0 (0.63)	114.0 (4.49)	12.7 (0.50)	21.2 x 18.4 dp (0.83 x 0.72 dp)	3/8*	21.0 (0.83)	153.0 (6.02)	39.0 (1.53)
140	158.0 (6.22)	210.0 (8.27)	16.0 (0.63)	128.0 (5.04)	12.7 (0.50)	21.2 x 18.4 dp (0.83 x 0.72 dp)	3/8*	21.0 (0.83)	168.0 (6.61)	39.0 (1.53)
160	178.0 (7.01)	238.0 (9.37)	17.0 (0.67)	144.0 (5.67)	14.5 (0.57)	24.2 x 21.2 dp (0.95 x 0.83 dp)	3/8*	21.0 (0.83)	188.0 (7.40)	39.0 (1.53)

'Q' Port Location by Bore and Stroke

BORE mm	STROKE mm		
	5-100	125, 150	175 - 300
32	8.7 (0.34)	12.7 (0.50)	–
40	9.2 (0.36)	12.7 (0.50)	–
50	10.5 (0.41)	13.2 (0.52)	–
63	11.5 (0.45)	18.5 (0.73)	–
80	14.0 (0.55)	14.0 (0.55)	–
100	18.0 (0.71)	18.0 (0.71)	–
125	24.5 (0.96)	24.5 (0.96)	24.5 (0.96)
140	24.5 (0.96)	24.5 (0.96)	24.5 (0.96)
160	27.5 (1.08)	27.5 (1.08)	27.5 (1.08)

'B' Dimensions by Bore and Stroke

measurements in millimeters and inches (in parenthesis)

BORE mm	STROKE	BORE mm				
		50	75	100	125	150
32	Std. Piston	73.0 (2.87)	108.0 (4.25)	133.0 (5.24)	172.8 (6.80)	197.8 (7.79)
	Mag. Piston	83.0 (3.27)	108.0 (4.25)	133.0 (5.24)	172.8 (6.80)	197.8 (7.79)
40	Std. Piston	79.5 (3.13)	114.5 (4.51)	139.0 (5.49)	180.5 (7.11)	205.5 (8.09)
	Mag. Piston	89.5 (3.52)	114.5 (4.51)	139.0 (5.49)	180.5 (7.11)	205.5 (8.09)
50	Std. Piston	80.5 (3.17)	115.5 (4.55)	140.5 (5.53)	184.3 (7.26)	209.3 (8.24)
	Mag. Piston	90.5 (3.56)	115.5 (4.55)	140.5 (5.53)	184.3 (7.26)	209.3 (8.24)
63	Std. Piston	86.0 (3.39)	121.0 (4.76)	146.0 (5.75)	189.6 (7.46)	214.6 (8.49)
	Mag. Piston	96.0 (3.78)	121.0 (4.76)	146.0 (5.75)	189.6 (7.46)	214.6 (8.49)
80	Std. Piston	93.5 (3.68)	128.5 (5.06)	153.5 (6.04)	194.5 (7.66)	219.5 (8.64)
	Mag. Piston	103.5 (4.07)	128.5 (5.06)	153.5 (6.04)	194.5 (7.66)	219.5 (8.64)
100	Std. Piston	103.0 (4.06)	138.0 (5.43)	163.0 (6.42)	201.7 (7.94)	226.7 (8.93)
	Mag. Piston	113.0 (4.45)	138.0 (5.43)	163.0 (6.42)	201.7 (7.94)	226.7 (8.93)
125	Std. & Mag.	133.0 (5.24)	158.0 (6.22)	183.0 (7.20)	208.0 (8.19)	233.0 (9.17)
140	Std. & Mag.	133.0 (5.24)	158.0 (6.22)	183.0 (7.20)	208.0 (8.19)	233.0 (9.17)
160	Std. & Mag.	141.0 (5.55)	166.0 (6.54)	191.0 (7.52)	216.0 (8.50)	241.0 (9.49)