

ACCESSORIES: CLEVIS, PINS & MOUNTS

Accessories Cross Reference Chart

CYLINDER MODEL				ACCESSORIES					
BORE	ROD SIZE	ROD STYLE (KK)	ROD THREAD	ROD CLEVIS	ROD EYE	CLEVIS PIN	CLEVIS BRACKET	EYE BRACKET	
1½, 2, 2½	5/8	#1 (STANDARD)	KK1	7/16-20	RC437	RE437	CP500	CB500	EB500
		#2	KK2	7/2-20	RC500	RE500	CP500		
	1	#1 (ST'D-OVERSIZE)	KK1	3/4-16	RC750	RE750	CP750		
		#4	KK4	1-14	RC1000	RE1000	CP1000		
3¼, 4, 5	1	#1 (STANDARD)	KK1	¾-16	RC750	RE750	CP750	CB750	EB750
		#4	KK4	1-14	RC1000	RE1000	CP1000		
	1⅜	#1 (ST'D-OVERSIZE)	KK1	1-14	RC1000	RE1000	CP1000		
		#2	KK2	1¼-12	RC1250	N/A	CP1375		
6 & 8	1⅜	#1 (STANDARD)	KK1	1-14	RC1000	RE1000	CP1000	CB1000	EB1000
		#2	KK2	1¼-12	RC1250	N/A	CP1375		
	1¾	#1 (ST'D-OVERSIZE)	KK1	1¼-12	RC1250	N/A	CP1375		
		#2	KK2	1½-12	RC1500	N/A	CP1750		
10	1¾	#1 (STANDARD)	KK1	1¼-12	RC1250	RE1250	CP1375	CB1375	EB1375
		#2	KK2	1½-12	RC1500	RE1500	CP1750	CB1750	EB1750
12	2	#1 (STANDARD)	KK1	1½-12	RC1500	RE1500	CP1750	CB1750	EB1750
		#1 (STANDARD)	KK1	1½-12	RC1500	RE1500	CP1750	CB1750	EB1750

CLEVIS PIN (WITH BRIDGE PIN - STANDARD)					
PART NO.	CD	H	HP	LH	LP
CP500	½	5/8	5/32	2¼	2¾
CP750	¾	15/16	5/32	3	2¾
CP1000	1	1⅜	13/64	3½	3⅞
CP1375	1⅜	1¾	¼	5	4½
CP1750	1¾	29/64	¼	6	5½



MATERIAL: 1018 CRS
FINISH: BLACK OXIDE

CLEVIS PIN (INCLUDES BRIDGE PIN)

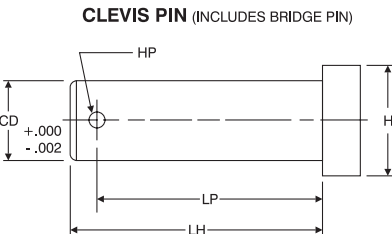

CLEVIS PIN (WITH COTTER PINS)			
PART NO.	CD	LH	LP
CP500C	½	2¼	1⅜
CP750C	¾	3	2¾
CP1000C	1	3½	3¾
CP1375C	1⅜	5	4¼
CP1750C	1¾	6	5½
CP2000C	2	6	5½

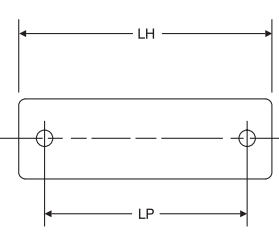

MATERIAL: 1045 CRS
FINISH: CHROME PLATED O.D.

CLEVIS PIN (INCLUDES COTTER PINS)

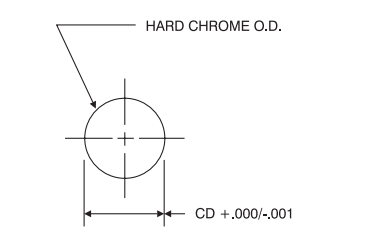

CLEVIS PIN (WITH E-RINGS)			
PART NO.	CD	LH	LP
CP500E	½	2⅜	1⅞
CP750E	¾	2⅜	2⅝
CP1000E	1	3⅞	3⅞

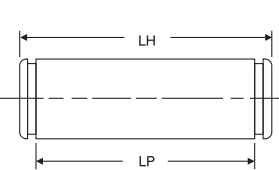

MATERIAL: 1045 CRS
FINISH: CHROME PLATED O.D.

CLEVIS PIN (INCLUDES E-RINGS)

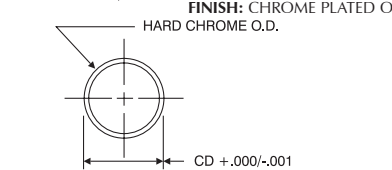

SMALL CLEVIS PIN (WITH BRIDGE PIN)				
PART NO.	CD	HP	LH	LP
CP500CCS	½	5/32	1⅜	1¼
CP750CCS	¾	5/32	2	1⅞

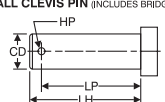

MATERIAL: 1018 CRS
FINISH: BLACK OXIDE

SMALL CLEVIS PIN (INCLUDES BRIDGE PIN)

SMALL ROD CLEVIS								
PART NO.	CB	CD	CE	CH	CW	KK1	KK2	L
RC437CCS	½	½	1⅜	1	¼	7/16-20	—	¾
RC500CCS	½	½	1⅜	1	¼	—	7/2-20	¾
RC750CCS	¾	¾	1¾	1½	3/8	¾-16	—	1

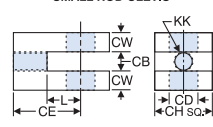

MATERIAL: 1018 CRS
FINISH: BLACK OXIDE

SMALL ROD CLEVIS

Rod Clevis, Pins, & Mounts

Alignment Couplers

TRD Magnetic Switches

Balluff Induction Switches

Accessories

Technical Data

Accessories: Clevis, Pins & Mounts

ROD CLEVIS								
PART NO.	CB	CD	CE	CH	CW	ER	KK	L
RC437	3/4	1/2	1 1/2	1	1/2	1/2	7/16-20	3/4
RC500							1/2-20	
RC750	1 1/4	3/4	2 3/8	1 1/4	5/8	3/4	3/4-16	1 1/4
RC1000	1 1/2	1	3 1/8	1 1/2	1/4	1	1-14	1 1/2
RC1250	2	1 3/8	4 1/8	2	1	1 3/8	1 1/4-12	2 1/8
RC1375	2	1 3/8	4 1/8	2	1	1 3/8	1 3/8-12	2 1/8
RC1500	2 1/2	1 3/4	4 1/2	2 3/8	1 1/4	1 3/4	1 1/2-12	2 1/4
RC1750	2 1/2	1 3/4	4 1/2	2 3/8	1 1/4	1 3/4	1 3/4-12	2 1/4
RC1875	2 1/2	2	5 1/2	3	1 1/4	2	1 7/8-12	2 1/2

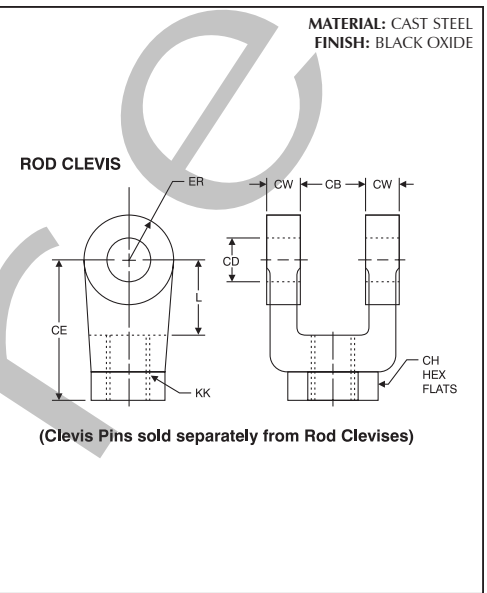

ROD EYE						
PART NO.	A	CA	CB	CD	ER	KK
RE437	3/4	1 1/2	3/4	1/2	5/8	7/16-20
RE500						1/2-20
RE750	1 1/8	2 1/16	1 1/4	3/4	7/8	3/4-16
RE1000	1 5/8	2 13/16	1 1/2	1	1 3/16	1-14
RE1250	2	3 7/16	2	1 3/8	1 9/16	1 1/4-12
RE1500	2 1/4	4	2 1/2	1 3/4	2	1 1/2-12

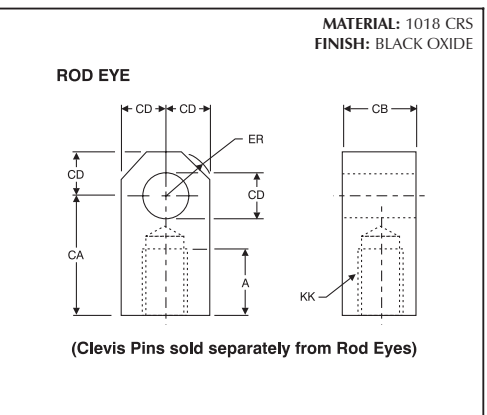

CLEVIS BRACKET										
PART NO.	BA	CB	CD	CW	DD	E	F	FL	L	M
CB500	1 5/8	3/4	1/2	1/2	3/8-24	2 1/2	3/8	1 1/8	3/4	5/8
CB750	2 9/16	1 1/4	3/4	5/8	1/2-20	3 1/2	5/8	1 7/8	1 1/4	3/4
CB1000	3 1/4	1 1/2	1	3/4	5/8-18	4 1/2	3/4	2 1/4	1 1/2	1
CB1375	3 13/16	2	1 3/8	1	5/8-18	5	7/8	3	2 1/8	1 3/8
CB1750	4 15/16	2 1/2	1 3/4	1 1/4	7/8-14	6 1/2	7/8	3 3/8	2 1/4	1 3/4

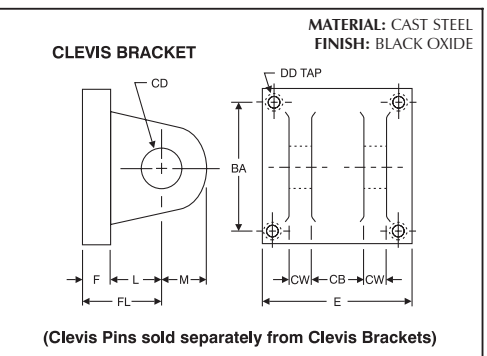

EYE BRACKET										
PART NO.	BA	CB	CD	DD	E	F	FL	L	M	
EB500	1 5/8	3/4	1/2	13/32	2 1/2	3/8	1 1/8	3/4	1/2	
EB750	2 9/16	1 1/4	3/4	17/32	3 1/2	5/8	1 7/8	1 1/4	3/4	
EB1000	3 1/4	1 1/2	1	21/32	4 1/2	3/4	2 1/4	1 1/2	1	
EB1375	3 13/16	2	1 3/8	21/32	5	7/8	3	2 1/8	1 3/8	
EB1750	4.95	2 1/2	1 3/4	29/32	6 1/2	7/8	3 3/8	2 1/4	1 3/4	

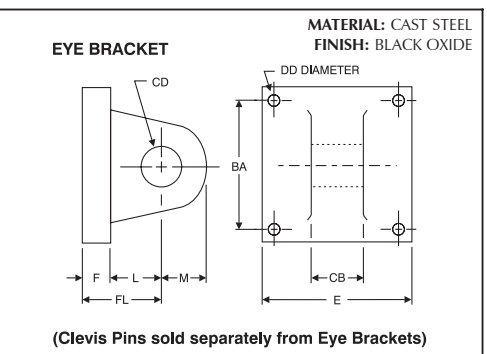

Rod Clevis, Pins, & Mounts

Alignment Couplers

TRD Magnetic Switches

Balluff Induction Switches

Accessories

Technical Data

ACCESSORIES: STAINLESS STEEL CLEVIS, PINS & MOUNTS

Stainless Steel Accessories Cross Reference Chart

CYLINDER MODEL				ACCESSORIES				
BORE	ROD SIZE	ROD STYLE (KK)	ROD THREAD	ROD CLEVIS	ROD EYE	CLEVIS PIN	CLEVIS BRACKET	EYE BRACKET
1½, 2, 2½	5/8	#1 (STANDARD) KK1	7/16-20	SS-RC437	SS-RE437	SS-CP500	SS-CB500	SS-EB500
		#2 KK2	½-20	SS-RC500	SS-RE500	SS-CP500		
	1	#1 (ST'D-OVERSIZE) KK1	¾-16	SS-RC750	SS-RE750	SS-CP750		
		#4 KK4	1-14	SS-RC1000	SS-RE1000	SS-CP1000		
3¼, 4, 5	1	#1 (STANDARD) KK1	¾-16	SS-RC750	SS-RE750	SS-CP750	SS-CB750	SS-EB750
		#4 KK4	1-14	SS-RC1000	SS-RE1000	SS-CP1000		
	1⅜	#1 (ST'D-OVERSIZE) KK1	1-14	SS-RC1000	SS-RE1000	SS-CP1000		
		#2 KK2	1¼-12	SS-RC1250	N/A	SS-CP1375		
6 & 8	1⅜	#1 (STANDARD) KK1	1-14	SS-RC1000	SS-RE1000	SS-CP1000	SS-CB1000	SS-EB1000
		#2 KK2	1¼-12	SS-RC1250	N/A	SS-CP1375		
	1¾	#1 (ST'D-OVERSIZE) KK1	1¼-12	SS-RC1250	N/A	SS-CP1375		
		#2 KK2	1½-12	SS-RC1500	N/A	SS-CP1750		

Accessories (303 Stainless Steel)

CLEVIS PIN (WITH COTTER PINS)			
PART NO.	CD	LH	LP
SS-CP500	½	2¼	1½/16
SS-CP750	¾	3	2²³/32
SS-CP1000	1	3½	3⁷/32
SS-CP1375	1⅜	5	4¼
SS-CP1750	1¾	6	5½

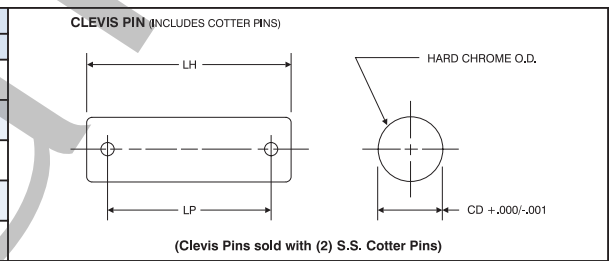

ROD CLEVIS							
PART NO.	CB	CD	CE	CW	ER	KK	L
SS-RC437	¾	½	1½	½	½	7/16-20	¾
SS-RC500						½-20	
SS-RC750	1¼	¾	2³/8	5/8	¾	¾-16	1¼
SS-RC1000	1½	1	3¹/8	¾	1	1-14	1½
SS-RC1250	2	1⅜	4¹/8	1	1⅜	1¼-12	2¹/8
SS-RC1500	2½	1¾	4½	1¼	1¾	1½-12	2¼

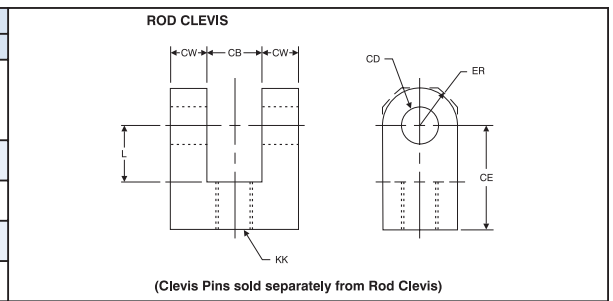

ROD EYE						
PART NO.	A	CA	CB	CD	ER	KK
SS-RE437	¾	1½	¾	½	5/8	7/16-20
SS-RE500						½-20
SS-RE750	1⅜	2¹/16	1¼	¾	7/8	¾-16
SS-RE1000	1⅝	2¹³/16	1½	1	1³/16	1-14
SS-RE1250	2	3⁷/16	2	1⅜	1⁹/16	1¼-12
SS-RE1500	2¼	4	2½	1¾	2	1½-12

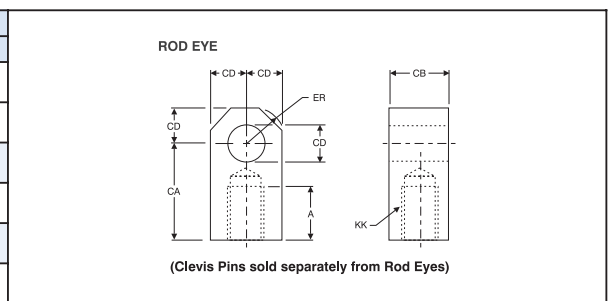

CLEVIS BRACKETS AND EYE BRACKETS											
	PART NO.	BA	CB	CD	CW	DD	E	F	FL	L	M
CLEVIS BRACKETS	SS-CB500	1⅝	¾	½	½	3/8-24	2½	3/8	1⅞	¾	5/8
	SS-CB750	2⁹/16	1¼	¾	5/8	½-20	3½	5/8	1⁷/8	1¼	¾
	SS-CB1000	3¼	1½	1	¾	5/8-18	4½	¾	2¼	1½	1
EYE BRACKETS	SS-EB500	1⅝	¾	½	N/A	1³/32	2½	3/8	1⅞	¾	1/2
	SS-EB750	2⁹/16	1¼	¾		1⁷/32	3½	5/8	1⁷/8	1¼	¾
	SS-EB1000	3¼	1½	1		2¹/32	4½	¾	2¼	1½	1

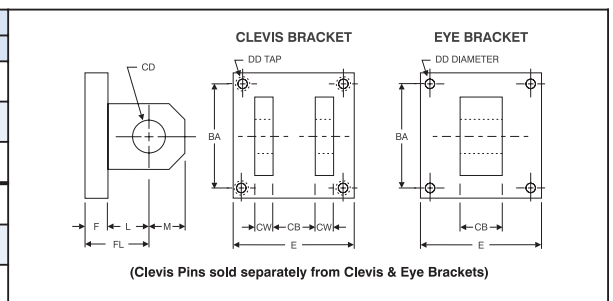

Vertical label: Rod Clevis, Pins, & Mounts

Vertical label: Alignment Couplers

Vertical label: TRD Magnetic Switches

Vertical label: Balluff Induction Switches

Vertical label: Accessories

Vertical label: Technical Data