

Ultran Cylinders

Ultran Cylinders	5.3-5.4
Ultran Slide Cylinders	5.5-5.12
Ultran Rodless Cylinders	5.13-5.23
High Load Ultran Cylinders	5.24-5.32
Ultran Application Checklist	5.33

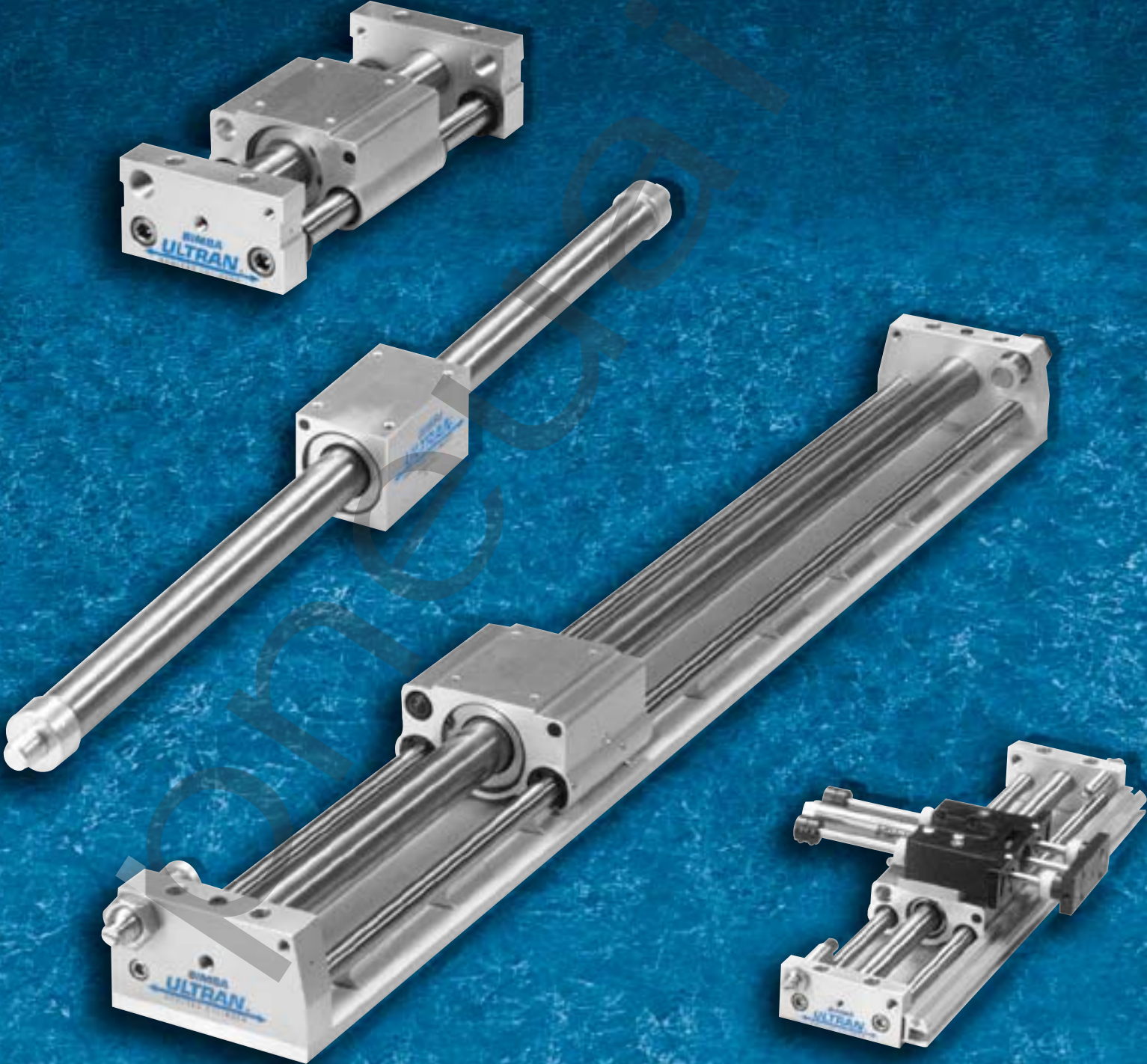

Ultran Cylinders

ORDER
ONLINE

Bimba Ultram Cylinders

SPACE SAVINGS OF ALMOST 50% IN MOST MODELS

Two Models:

- **Ultram Slide for self-guided motion**
- **Ultram for unguided or externally guided applications.**

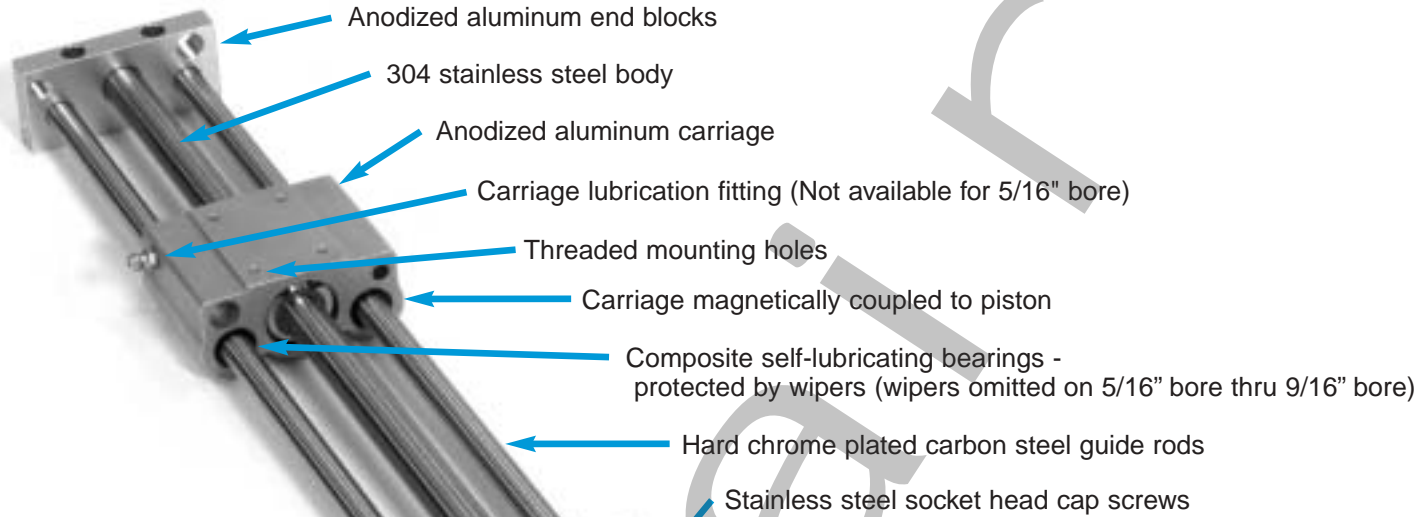

Ultram Slide

ADVANTAGES

- Leak-free construction.
- Lightweight.
- Piston seals are internally lubricated for long life.
- Special rare earth magnet configuration for high magnetic coupling strengths.
- 304 stainless steel body and "U" cup seals for lower dynamic friction.
- Pre-lubricated for miles of maintenance-free travel, with easily-accessible carriage lubrication port.
- Two magnetic coupling strength options available — Ultram Gold and Ultram Silver.
- Shock absorbers to decelerate loads (not available for 5/16" and 7/16" bore Ultram).
- Optional 1-inch stroke length adjustment available.
- Midstroke position sensing available for Ultram Slide. End-of-stroke sensing available for all models.
- Optional bumpers to reduce noise.
- Floating mount available for Ultram.
- Oil service seal option available for low pressure hydraulic service.
- Optional adjustable cushions or axial ports on Ultram (not available for 5/16" or 7/16" bore, 9/16" bore has fixed cushion).

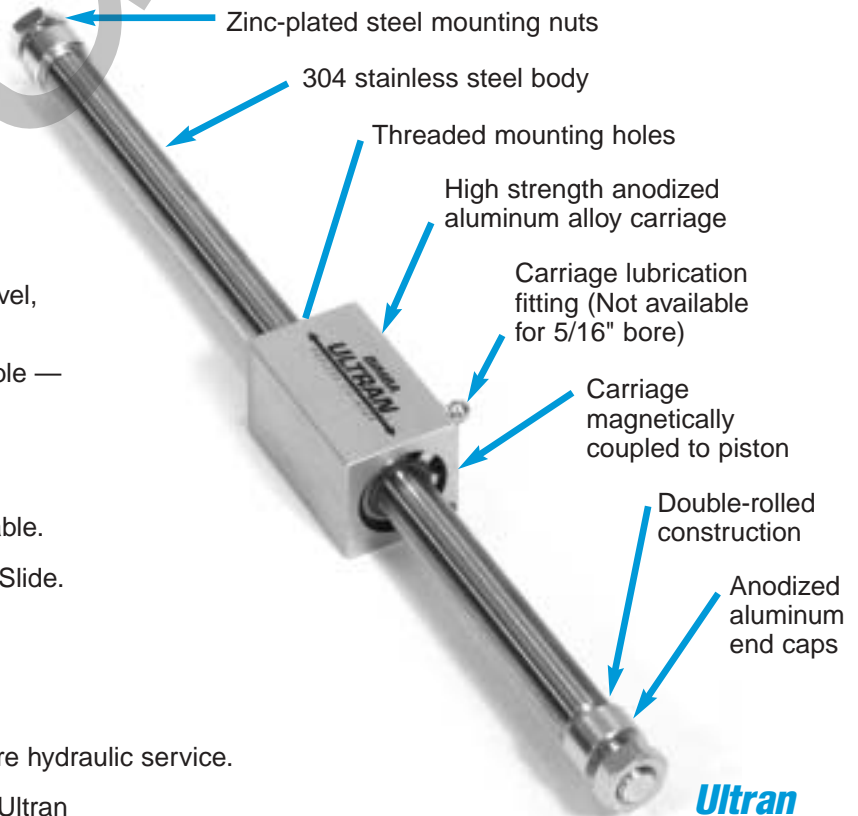

Ultram

ORDER
ONLINE

Bimba Ultram Cylinders

Ultram Slide

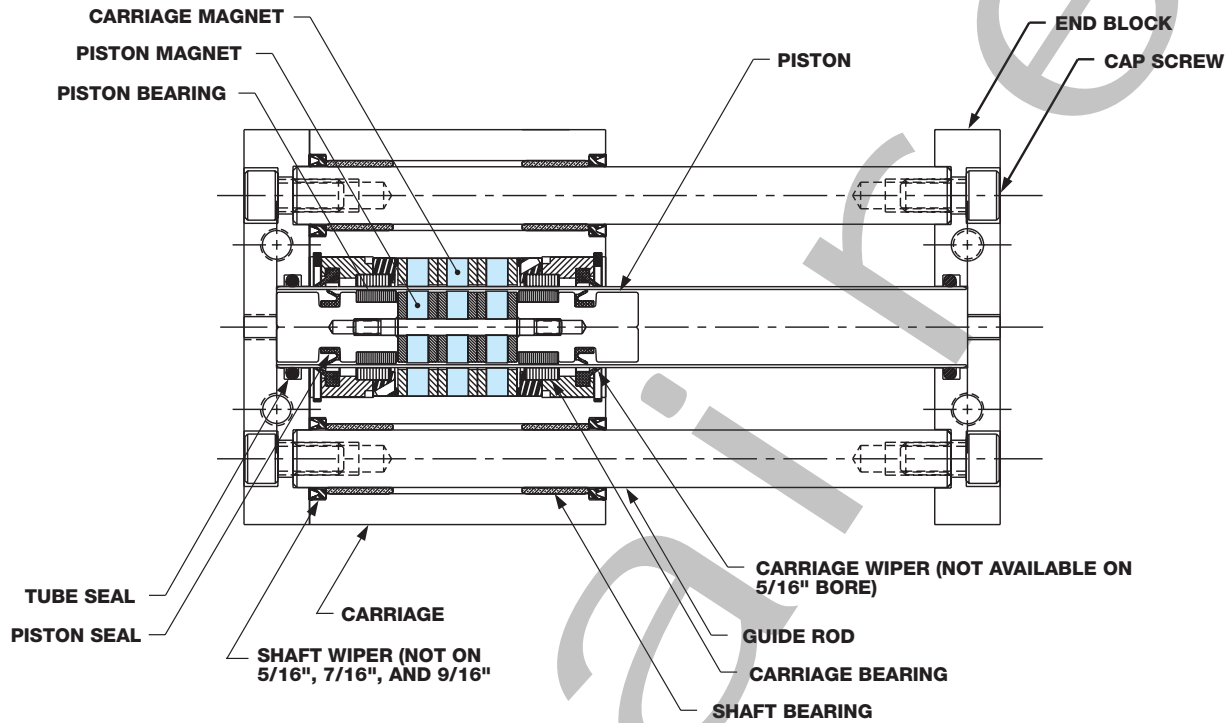

Ultram

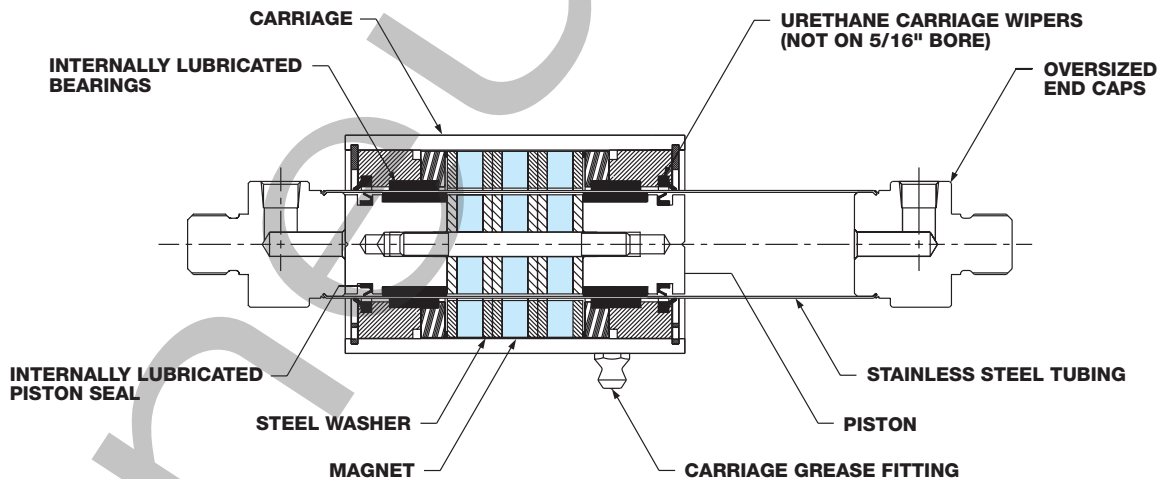

The cutaway drawings above show how the Bimba magnetically-coupled Ultram rodless cylinder works. Three magnets are located on the carriage. Three matching magnets are on the piston. (For 5/16" bore, five magnets are used.) These magnets form a strong bond that holds the carriage and piston together. When the cylinder is actuated, the piston and carriage move back and forth as one unit.

The magnetic attraction between the magnets determines a cylinder's magnetic coupling strength.

The Bimba Ultram rodless cylinder provides one of the highest coupling strengths available. This means it can carry higher loads without causing the piston to uncouple from the carriage. Bimba also offers two magnetic coupling strength options (Gold and Silver) to suit a wide variety of applications. The Silver option uses two sets of magnets instead of three. (For 5/16" bore, four sets of magnets are used.)

Bimba offers a model with built-in guides (Ultram Slide) and an unguided unit (Ultram).

Ultram
Cylinders

Ultram Slide
Cylinders

Ultram Rodless
Cylinders

High Load
Ultram Cylinders

Ultram Application
Checklist

Application Possibilities

Save space and streamline your design with the Bimba Ultram rodless cylinder.

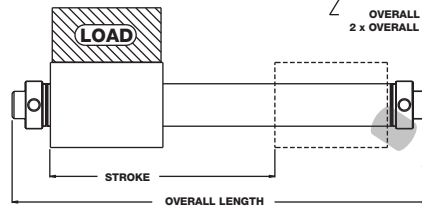
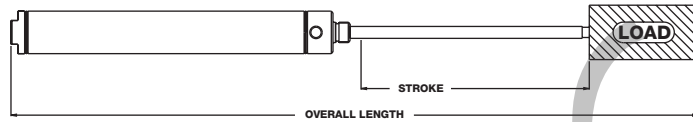

OVERALL LENGTH ORIGINAL LINE =
2 x OVERALL LENGTH RODLESS CYLINDER

Overall Length Savings

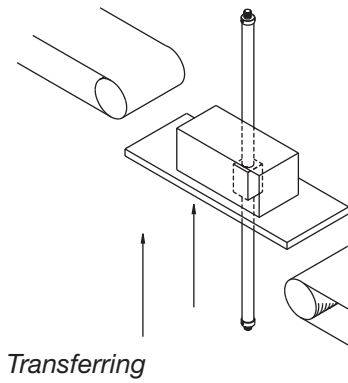

Transferring

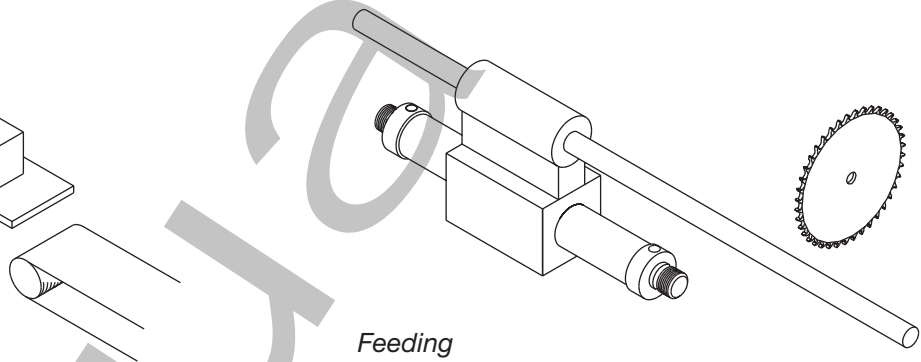

Feeding

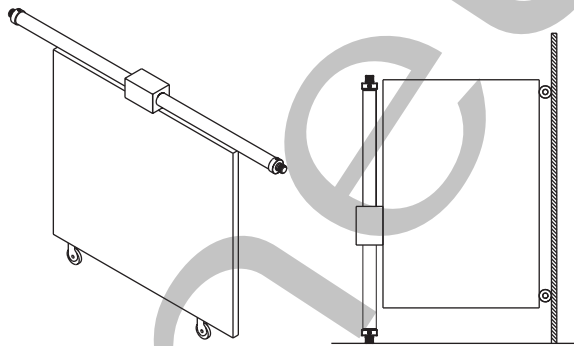

Door Opening

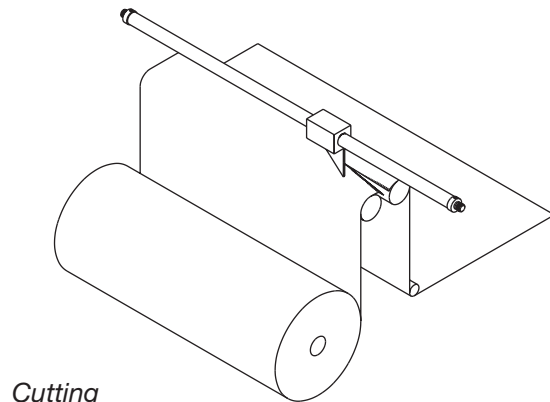

Cutting

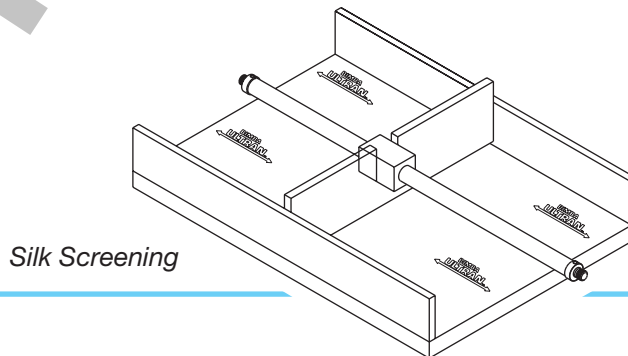

Silk Screening

Bimba Ultram Slide Cylinders

How to Order

The model number of all Ultram Slide cylinders consists of three alphanumeric clusters. These designate product type, bore size and stroke length, and options. Please refer to the charts below for an example of model number UGS-1723.375-A1T.

This is a 1-1/2" bore, 23.375" stroke Ultram Slide rodless cylinder with Ultram Gold coupling strength, with stroke adjustment on one end, and a track for mounting switches.

UGS -1723.375-A1T

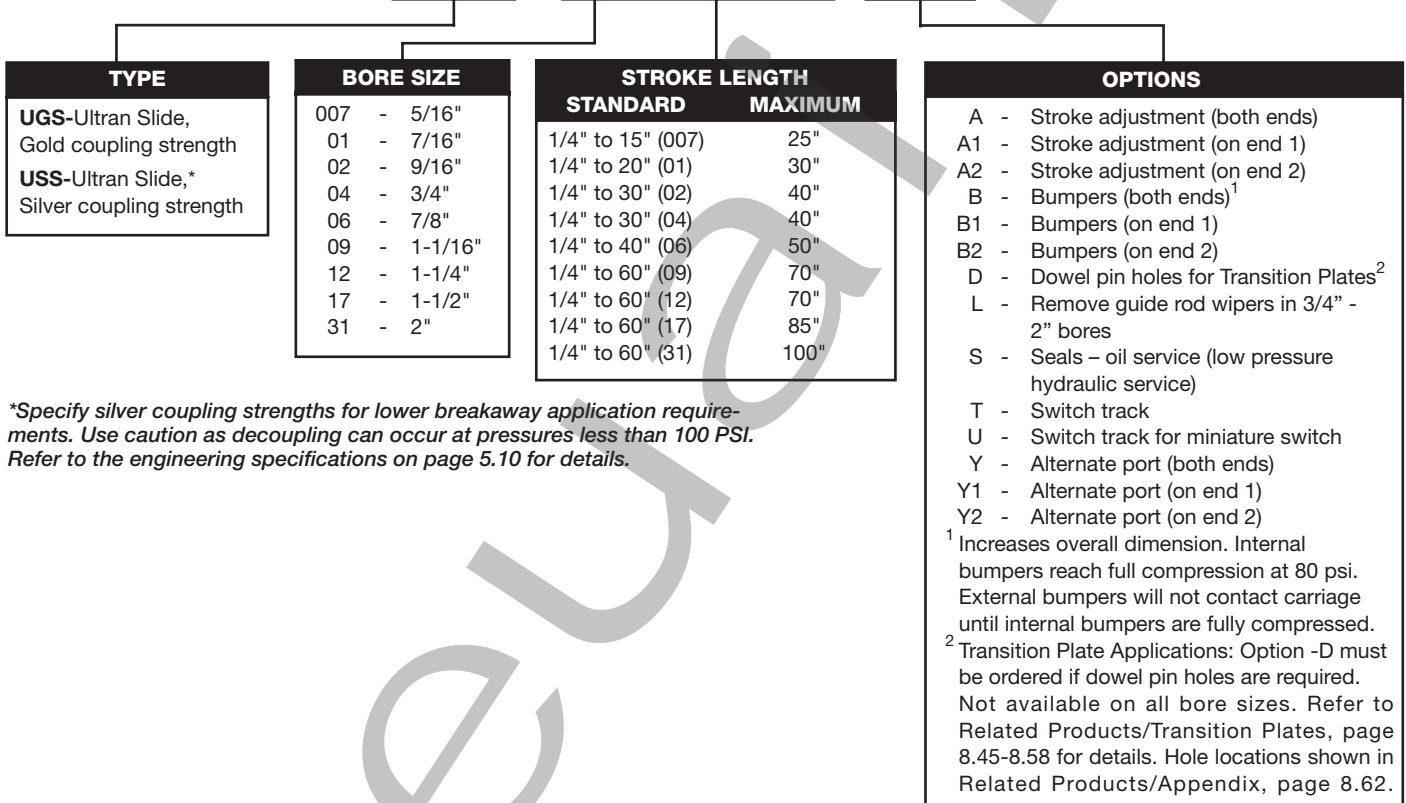

*Specify silver coupling strengths for lower breakaway application requirements. Use caution as decoupling can occur at pressures less than 100 PSI. Refer to the engineering specifications on page 5.10 for details.

¹ Increases overall dimension. Internal bumpers reach full compression at 80 psi. External bumpers will not contact carriage until internal bumpers are fully compressed.
² Transition Plate Applications: Option -D must be ordered if dowel pin holes are required. Not available on all bore sizes. Refer to Related Products/Transition Plates, page 8.45-8.58 for details. Hole locations shown in Related Products/Appendix, page 8.62.

Combination Availability

OPTION	A	B	D	S	T, U	Y
FOR ALL SIZES	D, S, T, Y	D, T, Y	A, B, D, S, T, Y	A, D, T, Y	A, B, D, S, Y	A, B, D, S, T

Note: Option -A can be ordered with option -B if they are ordered on different ends, i.e., A1B2 or A2B1.

Location

See diagram on pg. 5.7 for location of End 1 and End 2.

Ultram
Cylinders

Ultram Slide
Cylinders

Ultram Rodless
Cylinders

High Load
Ultram Cylinders

Ultram Application
Checklist

ORDER
ONLINE

Bimba Ultram Slide Cylinders

Dimensions (in.)

Bore	A	B	C	D	E	F	G	H	I	J	K
5/16" (007)	0.344	1.062	1.750	0.141	0.469	4-40 UNC	1.062	2.750	0.250	0.188	0.438
7/16" (01)	0.344	1.188	1.875	0.125	0.750	6-32 UNC	1.062	2.875	0.250	0.188	0.406
9/16" (02)	0.375	1.500	2.250	0.250	1.000	8-32 UNC	1.438	3.250	0.250	0.312	0.531
3/4" (04)	0.562	1.750	2.875	0.312	1.375	10-24 UNC	1.832	4.125	0.312	0.312	0.664
7/8" (06)	0.500	2.125	3.125	0.188	1.625	10-24 UNC	2.062	4.625	0.375	0.375	0.688
1-1/16" (09)	0.500	2.500	3.500	0.375	1.750	1/4-20 UNC	2.313	5.000	0.375	0.250	0.750
1-1/4" (12)	0.562	2.750	3.875	0.318	2.125	1/4-20 UNC	2.687	5.875	0.500	0.500	0.750
1-1/2" (17)	0.500	3.500	4.500	0.500	2.500	5/16-18 UNC	3.188	6.500	0.500	0.750	0.906
2" (31)	1.188	5.000	7.375	0.500	3.250	1/2-13 UNC	4.312	10.375	0.750	0.813	1.312

Bore	L	M	N	P	Q	R	S	V	W	X	X/X
5/16" (007)	N/A	N/A	0.750	N/A	0.188	0.500	2.000	0.215	0.215	1.000	0.562
7/16" (01)	0.395	0.788	0.938	0.288	0.219	0.500	2.312	0.218	0.220	1.000	0.562
9/16" (02)	0.455	0.982	1.250	0.297	0.250	0.500	3.000	0.406	0.281	1.375	0.749
3/4" (04)	0.572	1.239	1.625	0.234	0.313	0.625	3.375	0.406	0.313	1.750	0.957
7/8" (06)	0.635	1.438	1.625	0.225	0.312	0.750	3.750	0.500	0.438	2.000	1.063
1-1/16" (09)	0.706	1.549	1.875	0.172	0.375	0.750	4.250	0.594	0.375	2.250	1.188
1-1/4" (12)	0.750	1.562	2.125	0.162	0.375	1.000	4.812	0.656	0.562	2.625	1.375
1-1/2" (17)	0.756	1.736	2.500	0.109	0.438	1.000	6.000	1.000	0.906	3.125	1.625
2" (31)	1.500	2.688	3.250	0.000	0.250	1.500	8.000	1.125	0.938	4.250	2.188

Bore	Y	Z	AA	BB	CC	DD	EE	AAA	EEE
5/16" (007)	0.312	1.312	#6	5/16-24 UNF	3/8-32 UNEF	10-32	10-32 UNF	0.750	0.315
7/16" (01)	0.375	1.562	#10	5/16-24 UNF	3/8-32 UNEF	10-32	1/4-28 UNF	0.750	0.322
9/16" (02)	0.438	2.000	#10	5/16-24 UNF	7/16-28 UNEF	10-32	1/4-28 UNF	0.750	0.500
3/4" (04)	0.500	2.518	1/4	5/16-24 UNF	7/16-28 UNEF	1/8 NPT	5/16-24 UNF	1.080	0.625
7/8" (06)	0.625	2.750	1/4	5/16-24 UNF	1/2-20 UNF	1/8 NPT	5/16-24 UNF	1.375	0.625
1-1/16" (09)	0.750	3.062	5/16	5/16-24 UNF	1/2-20 UNF	1/8 NPT	3/8-24 UNF	1.375	0.750
1-1/4" (12)	0.812	3.500	5/16	5/16-24 UNF	3/4-16 UNF	1/8 NPT	3/8-24 UNF	1.750	0.750
1-1/2" (17)	1.000	4.500	3/8	5/16-24 UNF	3/4-16 UNF	1/8 NPT	7/16-20 UNF	1.750	0.750
2" (31)	1.500	5.750	3/4	5/16-24 UNF	1-12 UNF	1/4 NPT	7/8-9 UNC	3.125	1.000

NOTE: H+ stroke tolerance for stroke lengths less than 42" is +/- 0.032"
For stroke lengths greater than 42" the tolerance is +0.104/-0.047".

END 1

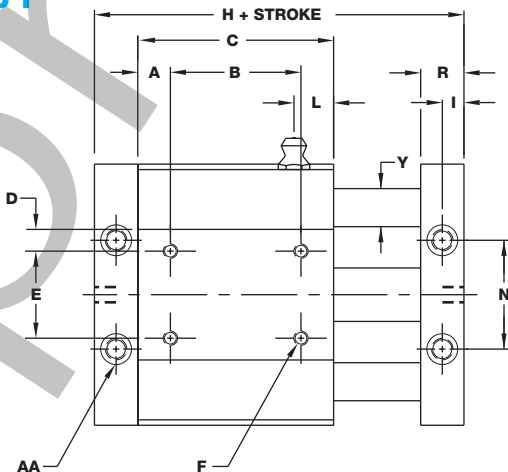

END 2

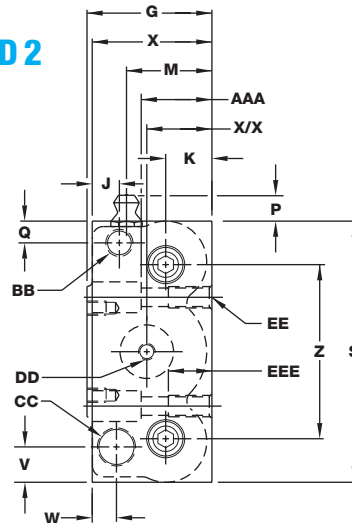

Options

Switch Track for Miniature Switches

Option T

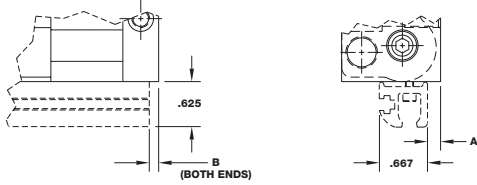

Option U



Bore	A	B	C	D
5/16" (007)	0.000	0.024	0.787	0.299
7/16" (01)	0.000	0.023	0.787	0.248
9/16" (02)	0.188	0.625	0.787	0.248
3/4" (04)	0.563	0.125	0.787	0.248
7/8" (06)	0.784	0.117	0.787	0.248
1-1/16" (09)	1.125	0.125	0.655	0.367
1-1/4" (12)	1.250	0.242	0.655	0.367
1-1/2" (17)	1.500	0.250	0.655	0.367
2" (31)	2.596	0.492	0.655	0.367

Shock Absorber/Stroke Adjustment (in.)

Bore	A	B	C	D	E	F
5/16" (007)	0.215	0.750	0.000	0.785	1.093	3/8-32 UNEF
7/16" (01)	0.218	0.750	0.000	0.780	1.093	3/8-32 UNEF
9/16" (02)	0.406	1.460	0.375	1.094	1.594	7/16-28 UNEF
3/4" (04)	0.406	1.335	0.375	1.438	1.469	7/16-28 UNEF
7/8" (06)	0.500	2.490	0.375	1.562	1.438	1/2-20 UNF
1-1/16" (09)	0.594	2.490	0.375	1.875	1.438	1/2-20 UNF
1-1/4" (12)	0.656	2.890	0.500	2.062	1.500	3/4-16 UNF
1-1/2" (17)	1.000	2.890	0.562	2.219	1.438	3/4-16 UNF
2" (31)	1.125	3.500	0.562	3.312	1.563	1-12 UNF

Shock Absorber

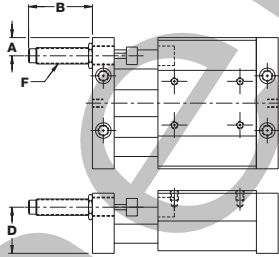

Stroke Adjustment

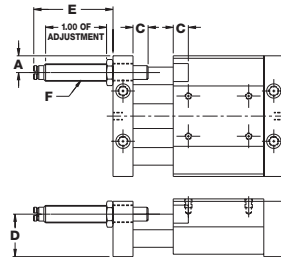

Note: Do not let the shock absorbers bottom out. The shock should not be used as a stroke adjuster. A stop collar is needed for the shock if stroke adjustment is required.

Alternate Port (in.)

Bore	A
5/16" (007)	0.162
7/16" (01)	0.150
9/16" (02)	0.162
3/4" (04)	0.188
7/8" (06)	0.312
1-1/16" (09)	0.312
1-1/4" (12)	0.500
1-1/2" (17)	0.500
2" (31)	0.750

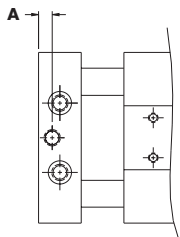

Note: 3/4" port size is 10-32, all other sizes are same as standard.

Bore	A
5/16" (007)	0.157
7/16" (01)	0.157
9/16" (02)	0.281
3/4" (04)	0.281
7/8" (06)	0.312
1-1/16" (09)	0.312
1-1/4" (12)	0.312
1-1/2" (17)	0.312
2" (31)	0.312

Bumper Adder (per end) (in.)

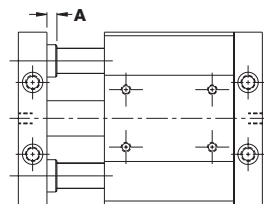

Note: Internal bumpers reach full compression at 80 psi. External bumpers will not contact carriage until internal bumpers are fully compressed.

Ultram Slide Mounting Instructions

Improper mounting of the Ultram slide could result in binding and/or excess breakaway. As a rule of thumb, the end blocks should be mounted flat with no more than 0.30° of differential misalignment end-to-end (including both end blocks, i.e., 0.30° on one end block if other end block is square. If both end blocks are out of square, the total between them cannot exceed 0.30° . The x dimension represents how much displacement 0.30° represents using $0.0175''$ per inch per degree of misalignment.)

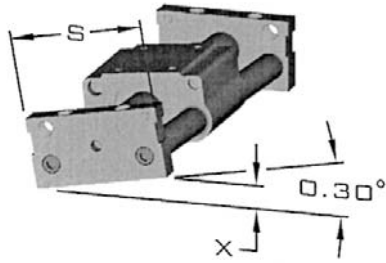

The following table shows the S dimension (End Block width dimension as found in the catalog) for all bore sizes:

Model	S in (mm)	x in (mm)
007 (5/16" Bore)	2.000 (50.8)	0.010 (0.25)
01 (7/16" bore)	2.312 (58.7)	0.012 (0.30)
02 (9/16" Bore)	3.000 (76.2)	0.016 (0.40)
04 (3/4" Bore)	3.375 (85.7)	0.018 (0.46)
06 (7/8" bore)	3.750 (95.3)	0.020 (0.51)
09 (1-1/16" Bore)	4.250 (108.0)	0.022 (0.56)
12 (1-1/4" bore)	4.812 (122.2)	0.025 (0.64)
17 (1-1/2" Bore)	6.000 (152.4)	0.031 (0.79)
31 (2" Bore)	8.000 (203.2)	0.042 (1.07)

For example:

- A Model 007 (5/16" bore) has a S dimension of 2.00". 0.30° of misalignment would yield approximately 0.010" of differential misalignment from end-to-end before binding and/or excess breakaway would occur.
- A Model 17 (1-1/2" Bore) has a S dimension of 6.00". 0.30° of misalignment would yield approximately 0.031" of differential misalignment from end-to-end before binding and/or excess breakaway would occur.

ORDER
ONLINE

Bimba Ultram Slide Cylinders

Engineering Specifications

Pressure Rating: 100 psi (Air or Hydraulic)
Temperature Range: 0° to 170°F
Breakaway: Ultram Slide Gold Coupling Strength - Less than 30 psi
 Ultram Slide Silver Coupling Strength - Less than 25 psi

Magnetic Coupling Strength (lbs.)

Cylinder Bore	Ultram Gold (UGS)	Ultram Silver (USS)
5/16" (007)	13	8
7/16" (01)	20	10
9/16" (02)	29	16
3/4" (04)	61	33
7/8" (06)	102	55
1-1/16" (09)	127	74
1-1/4" (12)	190	110
1-1/2" (17)	270	150
2" (31)	552	332

Weight (lbs.)

Cylinder Bore	(0" Stroke)		Adder per 1"
	(UGS)	(USS)	
5/16" (007)	0.24	0.23	0.05
7/16" (01)	0.52	0.51	0.08
9/16" (02)	1.44	1.38	0.10
3/4" (04)	2.70	2.58	0.13
7/8" (06)	3.61	3.49	0.21
1-1/16" (09)	5.66	5.47	0.28
1-1/4" (12)	7.38	7.12	0.35
1-1/2" (17)	14.48	13.90	0.49
2" (31)	38.48	37.17	1.13

Lubrication

The Ultram rodless cylinder is prelubricated at the factory. The life of the cylinder can be greatly lengthened by providing additional lubrication with an air line mist lubricator or direct introduction of oil to the cylinder every 100 linear miles of travel. Recommended oils are medium to heavy (20 to 30 weight). The carriage should also be lubricated every 100 linear miles with a high grade of bearing grease. Other types of prelubrication are available upon request. Guide shafts are self lubricating and require no external lubricants. The lubricant used by the factory can be ordered as part number MS-2861-14OZ. The lubricant is packaged in a 14 OZ grease gun cartridge.

Repairs

Bimba recommends that the Ultram Slide be returned to the factory for repairs. However, the following parts and kits are available for the Ultram Slide rodless cylinder.

PART	Cylinder Bore Size								
	5/16" (007)	7/16" (01)	9/16" (02)	3/4" (04)	7/8" (06)	1-1/16" (09)	1-1/4" (12)	1-1/2" (17)	2" (31)
Shaft bearing	RD-50644	RD-50645	RD-48996	RD-48997	RD-50646	RD-48998	RD-50647	RD-48999	RD-50648
Shaft wiper	N/A	N/A	RD-22720	RD-23079	RD-15679	RD-23086	RD-50656	RD-16174	RD-50657
Tube seal	RD-1476	RD-22653	RD-13012	RD-1078	RD-10050	RD-48874	RD-50769	RD-1147	RD-50770
Carriage bearing	RD-51006	RD-51007	RD-41631	RD-41633	RD-51433	RD-41635	RD-51434	RD-41637	RD-51438
Carriage wiper	N/A	RD-49806	RD-47191	RD-47192	RD-49805	RD-47193	RD-49804	RD-47194	RD-49803
Piston bearing	N/A	N/A	RD-41632	RD-41634	RD-51435	RD-41636	RD-51436	RD-41638	RD-51439
Piston seal	RD-13970-T	RD-13435-T	RD-45616	RD-45621	RD-50651	RD-45622	RD-50652	RD-45623	RD-50653
Piston bumper	RD-50468	RD-50469	RD-33072	RD-33073	RD-33073	RD-33071	RD-33071	RD-33076	RD-36326
Shaft bumper	RD-50802	RD-50803	RD-50279	RD-50280	RD-50804	RD-50281	RD-50805	RD-50282	RD-50806
Shaft washer	RD-50797	RD-50798	RD-50283	RD-50284	RD-50799	RD-50285	RD-50800	RD-50286	RD-50801
Body ¹	KUB-007	KUB-01	KUB-02	KUB-04	KUB-06	KUB-09	KUB-12	KUB-17	KUB-31
Guide Rods ¹	KUG-007	KUG-01	KUG-02	KUG-04	KUG-06	KUG-09	KUG-12	KUG-17	KUG-31
Switch Track ¹ -T	KUT-007	KUT-01	KUT-02	KUT-04	KUT-06	KUT-09	KUT-12	KUT-17	KUT-31
Switch Track ¹ -U	KUU-007	KUU-01	KUU-02	KUU-04	KUU-06	KUU-09	KUU-12	KUU-17	KUU-31
Repair kit ²	KU-007	KU-01	KU-02	KU-04	KU-06	KU-09	KU-12	KU-17	KU-31

¹ Option-B must be included at the end of part number if bumpers are being used with the Ultram Slide. (i.e., KUT-007-B)

² Includes required quantity of all except bumpers, oil service piston seals, bodies, guide rods and switch track, which are sold separately. Consult your local stocking Bimba distributor for prices.

Size/Application Considerations

Each bore size of the Bimba Ultram Slide rodless cylinder has specific load carrying capabilities. These capabilities can be enhanced by ordering external shock absorbers. Shock absorbers will also increase cylinder life when used properly. Use the following procedures to determine the requirements for specific applications.

NOTE: Exceeding the load can cause the carriage and piston to decouple.

1. *Check side load or radial load requirements.*

Graph A, Side Load/Radial Load vs. Stroke Length, shows the maximum load the cylinder will support for a specific bore size and stroke length.

2. *Check axial load requirements.* Graph B, Axial Load vs. Moment Arm, shows the maximum load the cylinder will support for a specific bore size and stroke length. Use the illustrations and formulas beside the graph to determine the load on the Ultram Slide.

3. *External Shock Absorbers.* If your load requirements fall above the curve for the specific bore size, external shock absorbers may allow you to decelerate the load. Choose from Graphs M through DD - *Velocity versus Load for Related Products*, page 8.38-8.40 for your bore size.

4. *Maximum Velocity.* If cylinder speed will exceed 20 in/sec or cycle rate will exceed 15 per minute, special application considerations may be required. Please consult your local distributor.

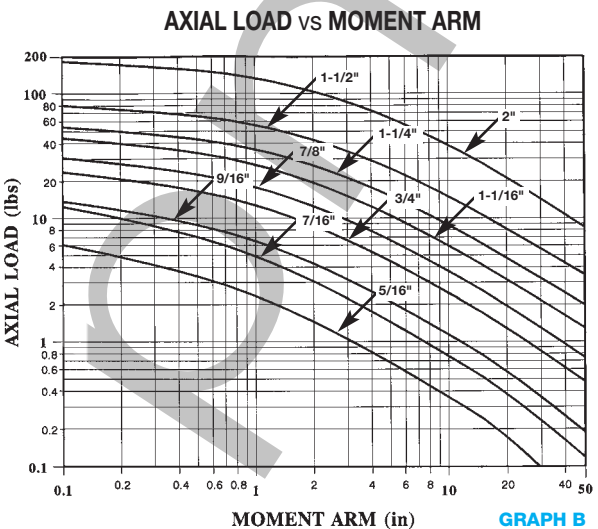
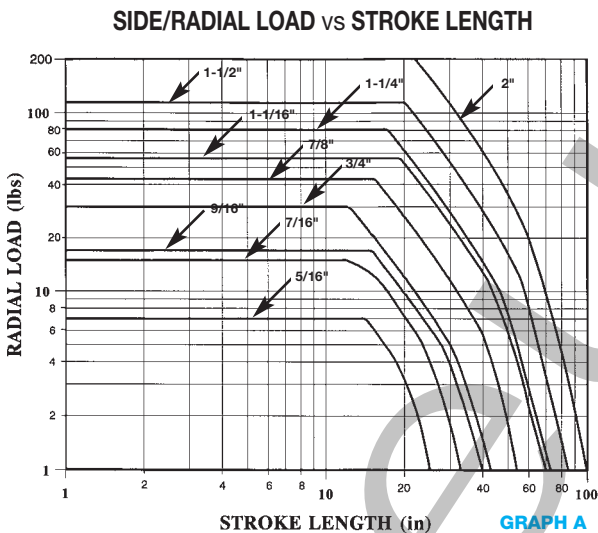

RADIAL LOAD

SEE GRAPH A

SIDE LOAD

SIDE LOAD = $2 \times \text{LOAD} \left(\frac{Y_1}{Z} + 1 \right)$

Cylinder Bore	Z
5/16" (007)	1.312
7/16" (01)	1.562
9/16" (02)	2.000
3/4" (04)	2.518
7/8" (06)	2.750
1-1/16" (09)	3.062
1-1/4" (12)	3.500
1-1/2" (17)	4.500
2" (31)	5.750

SEE GRAPH A

AXIAL LOAD

SEE GRAPH B

ORDER
ONLINE

Bimba Ultram Slide Cylinders

Size/Application Considerations

Moments About the Carriage:

The table below gives the maximum allowable moment an Ultram Slide will support. There are three different directions that the moment can be applied (see Sketch A).

Maximum Allowable Moment (in-lb)

Bore	Radial	Axial	Cross	H
	Mr max.	Ma max.	Mc max.	
5/16" (007)	2.3	5.2	5.2	0.625
7/16" (01)	4.9	9.4	9.4	0.656
9/16" (02)	6.6	17.2	17.2	0.906
3/4" (04)	11.1	37.5	37.5	1.168
7/8" (06)	14.3	68.4	68.4	1.374
1-1/16" (09)	19.5	89.1	89.1	1.563
1-1/4" (12)	26.5	160	160	1.937
1-1/2" (17)	40.4	250	250	2.281
2" (31)	67.0	800	800	3.000

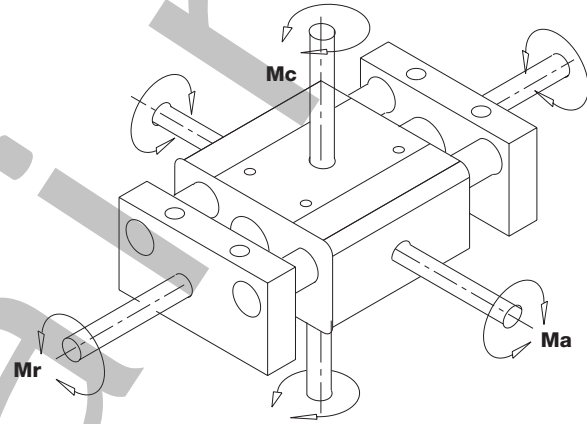

SKETCH A

Radial Moment

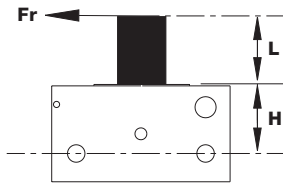

SKETCH B

Axial Moment

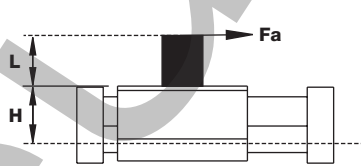

SKETCH C

Cross Moment

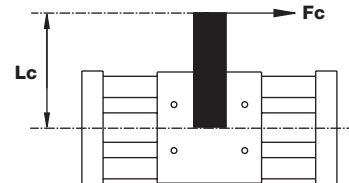

SKETCH D

Sketches B, C, and D demonstrate how a force is applied to a moment arm to produce the moments shown in Sketch A. Use the equations below to determine the actual moments created by your application. The results of each calculated moment should be compared to the maximums listed in the table. (If the actual moments are greater than the listed maximums, then the load and moments should be evaluated using the next larger Ultram Slide.)

$$\text{Radial Moment} = Mr = Fr \times (L+H)$$

$$\text{Axial Moment} = Ma = Fa \times (L+H)$$

$$\text{Cross Moment} = Mc = Fc \times (Lc)$$

An Ultram Slide can withstand compound moments but the maximum allowable will be determined by the total percentage of the axial, radial and cross moments. The equation below will determine the compound moment percent based on the total moments. The compound moment percent must not be greater than 100. (If the compound moment percent is greater than 100, then the load and moments should be evaluated using the next larger Ultram Slide.)

$$M_{\text{compound}} \% = 100 \times \left(\frac{Mr}{Mr_{\text{max}}} + \frac{Ma}{Ma_{\text{max}}} + \frac{Mc}{Mc_{\text{max}}} \right) \leq 100\%$$

Bimba Ultran Rodless Cylinders

ORDER
ONLINE

How to Order

The model number of all Ultran rodless cylinders consists of three alphanumeric clusters. These designate product type, bore size and stroke length, and options. Please refer to the charts below for an example of model number US-1766.375-A1B1F.

This is a 1-1/2" bore, 66.375" stroke, rodless cylinder with Ultran Silver coupling strength, with stroke adjustment on one end, bumpers on one end, and a floating mount bracket.

US - 1766.375 - A1B1F

TYPE	BORE SIZE	STROKE LENGTH STANDARD MAXIMUM	OPTIONS
UG -Ultran Rodless, Gold coupling strength US -Ultran Rodless, Silver coupling strength*	007 - 5/16" 01 - 7/16" 02 - 9/16" 04 - 3/4" 06 - 7/8" 09 - 1-1/16" 12 - 1-1/4" 17 - 1-1/2" 31 - 2"	1/4" to 30" (007) 30" 1/4" to 40" (01) 50" 1/4" to 40" (02) 90" 1/4" to 80" (04) 120" 1/4" to 80" (06) 120" 1/4" to 80" (09) 120" 1/4" to 80" (12) 120" 1/4" to 80" (17) 120" 1/4" to 80" (31) 120"	A - Stroke adjustment (both ends) A1 - Stroke adjustment (on end 1) A2 - Stroke adjustment (on end 2) B - Bumpers (both ends) B1 - Bumpers (on end 1) ¹ B2 - Bumpers (on end 2) C - Cushions (both ends) ² C1 - Cushions (on end 1)* C2 - Cushions (on end 2)* F - Floating mount bracket ³ K - Pivot (both ends) K1 - Pivot (on end 1) K2 - Pivot (on end 2) P - Axial ports both ends P1 - Axial port (on end 1) P2 - Axial port (on end 2) S - Seals – oil service (low pressure hydraulic service)

Combination Availability

OPTIONS		A	B	C	F	K	P	S
SIZES								
5/16"(007)	7/16"(01)	B,F,S	A,F,K,P	N/A	A,B,K,P,S	B,F,S	B,F,S	A,F,K,P
ALL OTHER SIZES		B,F,S	A,F,K,P	F,K	A,B,C,K,P,S	B,C,F,S	B,F,S	A,F,K,P

Location
See diagram on page 5.15 for location of End 1 and End 2. Incompatible options cannot be ordered on the same end (see combination availability chart above).

*Specify silver coupling strengths for lower breakaway application requirements. Use caution as decoupling can occur at pressures less than 100 PSI. Refer to the engineering specifications on page 5.20 for details.

¹80 PSI required to reach full stroke due to bumper compression.

²Not available for 5/16" and 7/16" bores. 9/16" bore has fixed cushions, other sizes have adjustable cushions.

³For use when application requirements dictate a non-parallel or floating interface with the ultran carriage to prevent binding between the ultran and external guiding systems. Refer to page 5.16 for angular, radial, and side float dimensions.

The 9/16" bore fixed cushion operates like an air spring. A small amount of air is trapped behind the piston to help slow it down. Since there is no air bleed-off, this air will remain trapped behind the piston until the cylinder is cycled. A minimum of 40 psi is needed to move the cylinder to full stroke. If air pressure is removed from the front side of the piston, the trapped air will act like a spring and move the piston away from the end cap about 3/16 of an inch.

See left column for option combination availability and location.

Ultran
Cylinders

Ultran Slide
Cylinders

Ultran Rodless
Cylinders

High Load
Ultran Cylinders

Ultran Application
Checklist

ORDER
ONLINE

ORDER
ONLINE

Bimba Ultran Rodless Cylinders

Dimensions (in.)

Bore	A	B	C	D	E	F	G	H	I	J
5/16" (007)	0.344	1.062	1.750	0.141	0.469	4-40 UNC	0.750	3.014	10-32	0.368
7/16" (01)	0.344	1.188	1.875	0.125	0.750	6-32 UNC	1.000	3.139	10-32	0.438
9/16" (02)	0.375	1.500	2.250	0.188	1.000	8-32 UNC	1.375	3.514	10-32	0.438
3/4" (04)	0.562	1.750	2.875	0.188	1.375	10-24 UNC	1.750	4.875	1/8 NPT	0.625
7/8" (06)	0.500	2.125	3.125	0.188	1.625	10-24 UNC	2.000	5.125	1/8 NPT	0.625
1-1/16" (09)	0.500	2.500	3.500	0.250	1.750	1/4-20 UNC	2.250	5.500	1/8 NPT	0.625
1-1/4" (12)	0.562	2.750	3.875	0.250	2.125	1/4-20 UNC	2.625	5.875	1/8 NPT	0.875
1-1/2" (17)	0.500	3.500	4.500	0.312	2.500	5/16-18 UNC	3.125	6.500	1/8 NPT	0.875
2" (31)	1.188	5.000	7.375	0.500	3.250	1/2-13 UNC	4.250	10.000	1/4 NPT	1.000

Bore	K	L	M	N	O	P	Q	R	S	U
5/16" (007)	5/16-24 NUT	N/A	N/A	0.125	0.188	0.203	0.406	0.632	0.625	0.500
7/16" (01)	7/16-20 NUT	0.395	0.312	0.125	0.250	0.203	0.406	0.632	0.704	0.688
9/16" (02)	7/16-20 NUT	0.455	0.312	0.220	0.250	0.203	0.406	0.632	0.755	0.688
3/4" (04)	5/8-18 NUT	0.572	0.375	0.312	0.375	0.315	0.630	1.000	0.985	0.938
7/8" (06)	5/8-18 NUT	0.635	0.375	0.375	0.375	0.315	0.630	1.000	1.110	0.938
1-1/16" (09)	5/8-18 NUT	0.706	0.500	0.375	0.375	0.315	0.630	1.000	1.297	0.938
1-1/4" (12)	3/4-16 NUT	0.750	0.375	0.500	0.420	0.315	0.630	1.000	1.545	1.125
1-1/2" (17)	3/4-16 NUT	0.756	0.750	0.520	0.420	0.315	0.630	1.000	1.735	1.125
2" (31)	1-1/4-12 NUT	1.500	0.750	0.750	0.500	0.438	0.875	1.312	2.312	1.875

END 1

END 2

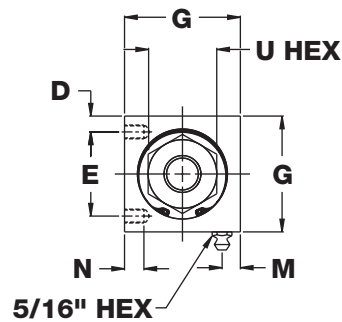
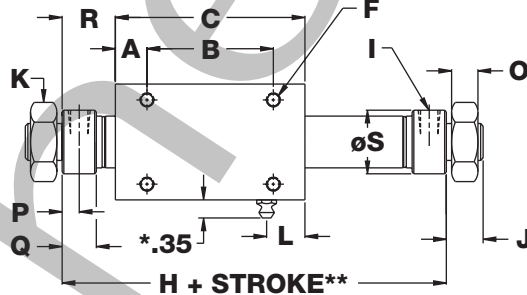

* Grease fitting on 2" bore is recessed.

** See page 5.16 for option length adders.

Ultran
Cylinders

Ultran Slide
Cylinders

Ultran Rodless
Cylinders

High Load
Ultran Cylinders

Ultran Application
Checklist

ORDER ONLINE Bimba Ultram Rodless Cylinders

Options

Stroke Adjustment Dimensions (in.)

Bore	A	B	C	D	E	F
5/16" (007)	0.625	0.203	0.406	0.094	6-40 UNF	0.188
7/16" (01)	0.704	0.203	0.406	0.109	10-32 UNF	0.250
9/16" (02)	0.755	0.203	0.406	0.109	10-32 UNF	0.250
3/4" (04)	0.985	0.315	0.630	0.156	1/4-28 UNF	0.375
7/8" (06)	1.110	0.315	0.630	0.188	5/16-24 UNF	0.375
1-1/16" (09)	1.297	0.315	0.630	0.188	5/16-24 UNF	0.375
1-1/4" (12)	1.545	0.315	0.630	0.220	3/8-24 UNF	0.420
1-1/2" (17)	1.735	0.315	0.630	0.220	3/8-24 UNF	0.420
2" (31)	2.312	0.438	0.875	0.250	7/16-20 UNF	0.500

Bore	G	I	J	K	L	M
5/16" (007)	10-32	0.368	0.500	0.188	1.795	5/16-24 NUT
7/16" (01)	10-32	0.438	0.688	0.313	1.469	7/16-20 NUT
9/16" (02)	10-32	0.438	0.688	0.313	1.469	7/16-20 NUT
3/4" (04)	1/8-NPT	0.625	0.938	0.438	1.905	5/8-18 NUT
7/8" (06)	1/8-NPT	0.625	0.938	0.438	1.943	5/8-18 NUT
1-1/16" (09)	1/8-NPT	0.625	0.938	0.438	1.943	5/8-18 NUT
1-1/4" (12)	1/8-NPT	0.875	1.125	0.563	2.115	3/4-16 NUT
1-1/2" (17)	1/8-NPT	0.875	1.125	0.563	2.115	3/4-16 NUT
2" (31)	1/4-NPT	1.000	1.875	0.688	2.278	1-1/4-12 NUT

Stroke Adjustment

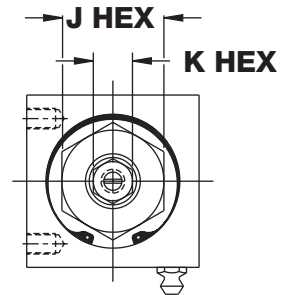
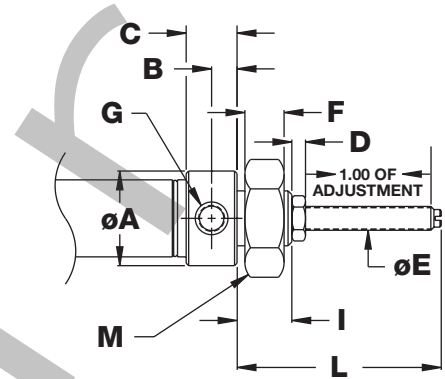

Stroke Adjustment Length Adder (in.)

Bore	5/16" (007)	7/16" (01)	9/16" (02)	3/4" (04)	7/8" (06)	1-1/16" (09)	1-1/4" (12)	1-1/2" (17)	2" (31)
Add to overall length: (per end)	0.044	0.060	0.060	0.060	0.080	0.080	0.110	0.110	0.120

Bumper Length Adder (in.)

Bore	5/16" (007)	7/16" (01)	9/16" (02)	3/4" (04)	7/8" (06)	1-1/16" (09)	1-1/4" (12)	1-1/2" (17)	2" (31)
Add to overall length: (per end)	0.095	0.120	0.120	0.140	0.140	0.150	0.150	0.150	0.200

Cushions (Not available for 5/16" and 7/16" bores) (in.)

Bore	A	B	C	E	I	J	K	L
9/16" (02)	0.755	10-32	0.250	0.438	0.688	0.203	0.406	7/16-20 NUT
3/4" (04)	0.985	1/8 NPT	0.375	0.625	0.938	0.315	0.630	5/8-18 NUT
7/8" (06)	1.110	1/8 NPT	0.375	0.625	0.938	0.315	0.630	5/8-18 NUT
1-1/16" (09)	1.297	1/8 NPT	0.375	0.625	0.938	0.315	0.630	5/8-18 NUT
1-1/4" (12)	1.545	1/8 NPT	0.420	0.875	1.125	0.315	0.630	3/4-16 NUT
1-1/2" (17)	1.735	1/8 NPT	0.420	0.875	1.125	0.315	0.630	3/4-16 NUT
2" (31)	2.312	1/4 NPT	0.500	1.000	1.875	0.438	0.875	1-1/4-12 NUT

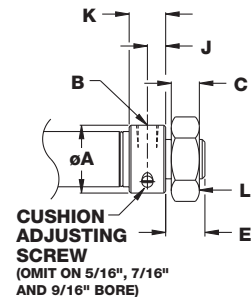

Note: There is no length adder for the cushion option.

Bimba Ultram Rodless Cylinders

Options

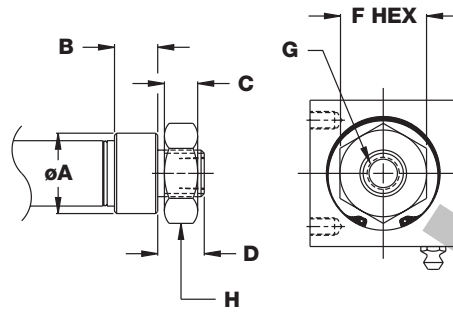

Axial Ports (in.)

Bore	A	B	C	D	F	G	H
5/16" (007)	0.625	0.406	0.188	0.368	0.500	10-32	5/16-24 NUT
7/16" (01)	0.704	0.406	0.250	0.438	0.688	10-32	7/16-20 NUT
9/16" (02)	0.755	0.406	0.250	0.438	0.688	10-32	7/16-20 NUT
3/4" (04)	0.985	0.630	0.375	0.625	0.938	1/8 NPT	5/8-18 NUT
7/8" (06)	1.110	0.630	0.375	0.625	0.938	1/8 NPT	5/8-18 NUT
1-1/16" (09)	1.297	0.630	0.375	0.625	0.938	1/8 NPT	5/8-18 NUT
1-1/4" (12)	1.545	0.630	0.420	0.875	1.125	1/8 NPT	3/4-16 NUT
1-1/2" (17)	1.735	0.630	0.420	0.875	1.125	1/8 NPT	3/4-16 NUT
2" (31)	2.312	0.875	0.500	1.000	1.875	1/4 NPT	1-1/4-12 NUT

Note: There is no length adder for the Axial port option.

Floating Mount Bracket (in.)

Bore	A	B	C	D	E	F	G	H	I	J	K
5/16" (007)	0.532	1.438	0.188	0.187	1.317	1.062	0.469	0.188	0.360	4-40 UNC	0.236
7/16" (01)	0.625	1.688	0.188	0.249	1.646	1.188	0.750	0.250	0.383	6-32 UNC	0.248
9/16" (02)	0.750	1.875	0.188	0.249	2.005	1.500	1.000	0.188	0.437	8-32 UNC	0.278
3/4" (04)	0.875	2.375	0.250	0.312	2.442	1.750	1.375	0.312	0.459	10-24 UNC	0.340
7/8" (06)	0.938	2.750	0.312	0.374	2.849	2.125	1.625	0.312	0.547	10-24 UNC	0.421
1-1/16" (09)	1.062	3.000	0.312	0.374	3.068	2.500	1.750	0.250	0.594	1/4-20 UNC	0.421
1-1/4" (12)	1.125	3.562	0.375	0.437	3.599	2.750	2.125	0.406	0.672	1/4-20 UNC	0.484
1-1/2" (17)	1.188	4.250	0.375	0.437	4.068	3.500	2.500	0.375	0.719	5/16-18 UNC	0.484
2" (31)	1.938	6.500	0.500	0.624	6.000	5.000	3.250	0.750	1.250	1/2-13 UNC	0.634

Bore	L	M	N	O
5/16" (007)	0.250	1.188	1.019	1.019
7/16" (01)	0.312	1.516	1.206	1.206
9/16" (02)	0.312	1.875	1.518	0.938
3/4" (04)	0.375	2.312	1.861	1.156
7/8" (06)	0.438	2.719	2.080	1.359
1-1/16" (09)	0.438	2.937	2.330	1.469
1-1/4" (12)	0.500	3.469	2.612	1.734
1-1/2" (17)	0.500	3.937	2.924	1.969
2" (31)	0.688	5.750	4.268	2.875

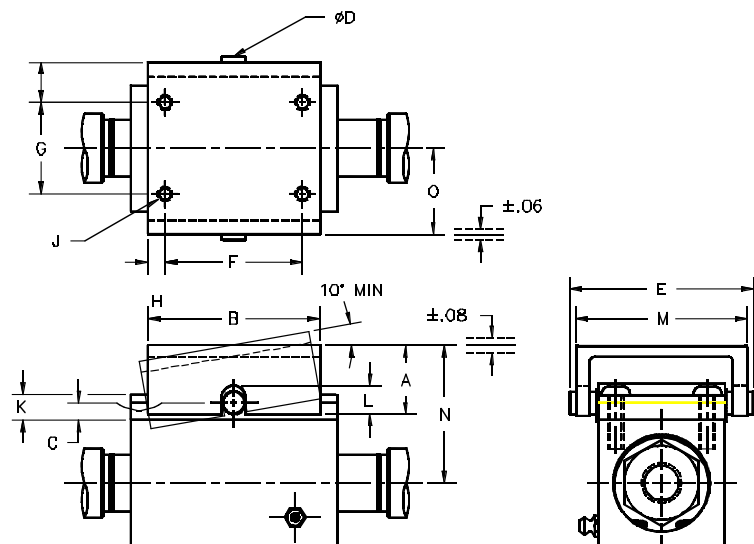

ORDER
ONLINE

Bimba Ultram Rodless Cylinders

Options

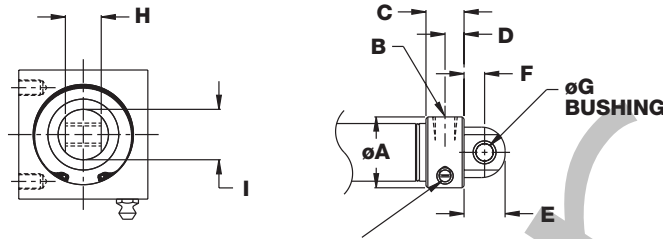

**CUSHION OPTION ONLY CUSHION ADJUSTMENT SCREW
LOCATION FOR 04, 06, 09, 12, 17, AND 31 BORES**

Pivot Option (in.)

Bore	A	B	C	D	E	F	G	H	I
5/16" (007)	0.625	10-32	0.406	0.203	0.368	0.212	0.127	0.243	0.375
7/16" (01)	0.704	10-32	0.406	0.203	0.437	0.250	0.157	0.305	0.500
9/16" (02)	0.755	10-32	0.406	0.203	0.437	0.250	0.157	0.305	0.500
3/4" (04)	0.985	1/8- NPT	0.630	0.315	0.625	0.344	0.253	0.368	0.750
7/8" (06)	1.110	1/8- NPT	0.630	0.315	0.625	0.344	0.253	0.368	0.750
1-1/16" (09)	1.297	1/8- NPT	0.630	0.315	0.625	0.344	0.253	0.368	0.875
1-1/4" (12)	1.545	1/8- NPT	0.630	0.315	0.875	0.500	0.378	0.493	1.000
1-1/2" (17)	1.735	1/8- NPT	0.630	0.315	0.875	0.500	0.378	0.493	1.125
2" (31)	2.312	1/4- NPT	0.876	0.438	1.000	0.500	0.439	0.868	1.375

Accessories

Shock Absorber/ Switch Bracket (For 9/16" bore and larger only)

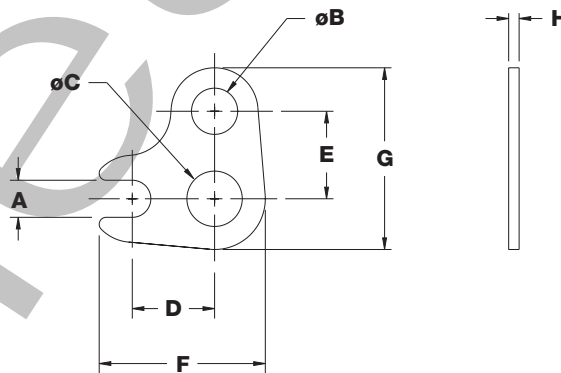

Shock Absorber/Switch Bracket (Not available for 5/16" and 7/16" bores) (in.)

Bore	A	B	C	D	E	F	G	H
9/16" (02)	0.320	0.399	0.442	0.710	0.755	1.433	1.568	0.090
3/4" (04)	0.320	0.478	0.629	0.910	0.900	1.820	1.900	0.120
7/8" (06)	0.320	0.556	0.629	0.875	1.116	1.785	2.179	0.120
1-1/16" (09)	0.320	0.556	0.629	0.910	1.047	1.820	2.110	0.120
1-1/4" (12)	0.320	0.793	0.754	0.375	1.437	2.410	2.812	0.120
1-1/2" (17)	0.320	0.793	0.754	1.450	1.453	2.485	2.828	0.120
2" (31)	0.320	1.005	1.254	2.230	2.290	3.640	4.165	0.224

- A - Slot for Switch
- B - Hole for Shock Absorber
- C - Hole for Cylinder

ORDER
ONLINE

Bimba Ultram Rodless Cylinders

Mounting Block (in.)

Bore	A	B	C	D	E	F	G	H	J	K	L
5/16" (007)	2.000	0.375	0.875	0.188	0.813	0.250	0.272	0.159	5/16-24 UNF	0.500	N/A
7/16" (01)	2.500	0.500	1.125	0.250	0.938	0.250	0.357	0.213	5/16-24 UNF	0.562	N/A
9/16" (02)	2.500	0.500	1.500	0.250	1.000	0.250	0.354	0.213	5/16-24 UNF	0.520	0.520
3/4" (04)	3.500	0.750	1.875	0.375	1.312	0.375	0.422	0.272	5/16-24 UNF	0.671	0.671
7/8" (06)	3.500	0.750	2.125	0.375	1.375	0.375	0.422	0.273	5/16-24 UNF	0.789	0.789
1-1/16" (09)	4.000	0.750	2.500	0.375	1.563	0.375	0.515	0.332	5/16-24 UNF	0.893	0.893
1-1/4" (12)	5.000	1.000	2.875	0.500	2.000	0.443	0.609	0.391	5/16-24 UNF	1.062	1.016
1-1/2" (17)	5.000	1.000	3.375	0.500	2.000	0.443	0.609	0.391	5/16-24 UNF	1.240	1.240
2" (31)	8.500	1.500	4.500	0.750	3.250	1.000	1.187	0.779	5/16-24 UNF	1.625	1.607

J - Hole for Switch
M - Hole for Shock Absorber

Bore	M	N	P	Q	R	S	T	U	V	W	X
5/16" (007)	N/A	0.312	0.250	N/A	0.438	0.315	6-40 UNF	0.318	0.776	6-40 UNF	0.594
7/16" (01)	N/A	0.380	0.375	N/A	0.563	0.380	1/4-28 UNF	0.442	0.995	1/4-28 UNF	0.688
9/16" (02)	3/8-32 UNEF	0.500	0.520	0.520	0.750	0.500	1/4-28 UNF	0.442	1.000	1/4-28 UNF	0.688
3/4" (04)	7/16-28 UNEF	0.625	0.671	0.671	0.938	0.500	5/16-24 UNF	0.629	1.375	5/16-24 UNF	0.938
7/8" (06)	1/2-20 UNF	0.625	0.789	0.789	1.063	0.750	5/16-24 UNF	0.629	1.375	5/16-24 UNF	0.938
1-1/16" (09)	1/2-20 UNF	0.875	0.893	0.893	1.250	0.750	3/8-24 UNF	0.629	1.375	3/8-24 UNF	1.125
1-1/4" (12)	3/4-16 UNF	1.125	1.062	1.016	1.438	1.125	7/16-20 UNF	0.754	1.625	7/16-20 UNF	1.375
1-1/2" (17)	3/4-16 UNF	1.375	1.240	1.240	1.688	1.000	7/16-20 UNF	0.753	1.625	7/16-20 UNF	1.375
2" (31)	1-12 UNF	1.625	1.625	1.607	2.250	1.500	7/8-9 UNC	1.380	2.750	7/8-9 UNC	2.125

Mounting Block

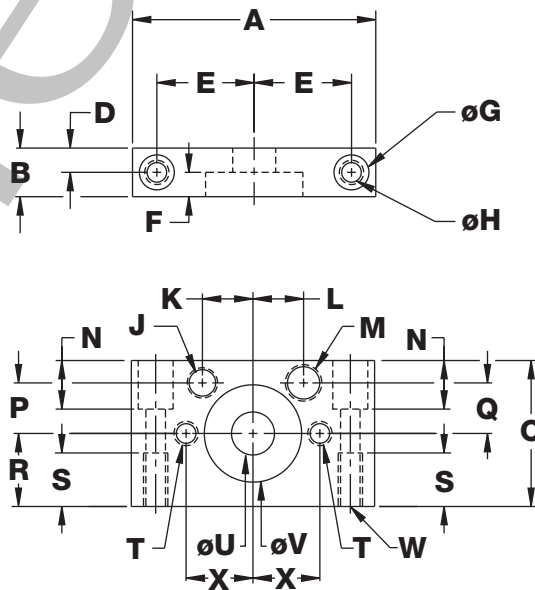

Ultram
Cylinders

Ultram Slide
Cylinders

Ultram Rodless
Cylinders

High Load
Ultram Cylinders

Ultram Application
Checklist

ORDER
ONLINE

Bimba Ultran Rodless Cylinders

Engineering Specifications

Pressure Rating: 100 psi (Air or Hydraulic)
Temperature Range: 0° to 170°F
Breakaway: Ultran Gold Coupling Strength - Less than 25 psi
Ultran Silver Coupling Strength - Less than 20 psi

Magnetic Coupling Strength (lbs.)

Cylinder Bore	Ultran Gold (UGS)	Ultran Silver (USS)
5/16" (007)	13	8
7/16" (01)	20	10
9/16" (02)	29	16
3/4" (04)	61	33
7/8" (06)	102	55
1-1/16" (09)	127	74
1-1/4" (12)	190	110
1-1/2" (17)	270	150
2" (31)	552	332

Lubrication

The Ultran rodless cylinder is prelubricated at the factory. The life of the cylinder can be greatly lengthened by providing additional lubrication with an air line mist lubricator or direct introduction of oil to the cylinder every 100 linear miles of travel. Recommended oils are medium to heavy.

The carriage should also be lubricated every 100 linear miles with a high grade of bearing grease. Other types of prelubrication are available upon request. The lubricant used by the factory can be ordered as part number MS-2861-14OZ. the lubricant is packaged in a 14 OZ grease gun cartridge.

Repairs

The Ultran rodless cylinder must be returned to the factory for repairs.

Weight (lbs.)

Cylinder Bore	Base Weight (0" Stroke)		Adder per 1"
	(UG)	(US)	
5/16" (007)	0.10	0.09	0.006
7/16" (01)	0.22	0.21	0.01
9/16" (02)	0.56	0.51	0.01
3/4" (04)	1.18	1.11	0.02
7/8" (06)	1.54	1.42	0.02
1-1/16" (09)	2.54	2.34	0.03
1-1/4" (12)	3.16	2.90	0.03
1-1/2" (17)	6.36	5.76	0.05
2" (31)	16.46	15.15	0.07

ORDER ONLINE Bimba Ultram Rodless Cylinders

Size/Application Considerations

Each bore size for the Bimba Ultram rodless cylinder has specific load carrying capabilities. These capabilities can be enhanced by externally supporting the load or by ordering the internal cushion option or external shock absorbers. The load should always be guided and supported for optimum life. Cushions or shock absorbers will also increase cylinder life when used properly. Use the following procedures to determine the requirements for specific applications.

NOTE: Exceeding the load can cause the carriage and piston to decouple.

1. **Check radial load requirements.** Graph C, *Radial Load vs. Stroke Length*, shows the maximum radial load the cylinder will support for a specific bore size and stroke length. If your radial load requirements fall above the curve, the load must be externally supported.

2. **Check axial load requirements.** Graph D, *Axial Load vs. Moment Arm*, shows the maximum axial load the cylinder will support for a specific bore size and moment arm length. If your axial load requirements fall above the curve for the specific bore size, the load must be externally supported.

3. **Check End-of-Stroke Velocity and Load Requirements.** From Graphs E through H, *Velocity vs. Load*, choose the graph for your Ultram model and mounting position. If your velocity and load requirements fall above the curve for the specific bore size, you will need internal cushions or external shock absorbers to decel-

erate the load without causing the carriage and piston to decouple.

4. **Maximum Velocity.** If cylinder speed will exceed 20 in/sec or cycle rate will exceed 15 per minute, special application considerations may be required. Please consult your local distributor.

Internal Cushions. From Graphs I through L, *Velocity vs. Load for Cushions*, choose the graph for your Ultram model and mounting position. If your velocity and load requirements fall above the curve for the specific bore size, you will need external shock absorbers to decelerate the load.

External Shock Absorbers. Choose from Graphs EE through RR (*Related Products*, page 8.38-8.40), *Velocity vs. Load for Shock Absorbers*, for your bore size. Choose model LS, SS or HS based on your velocity and load.

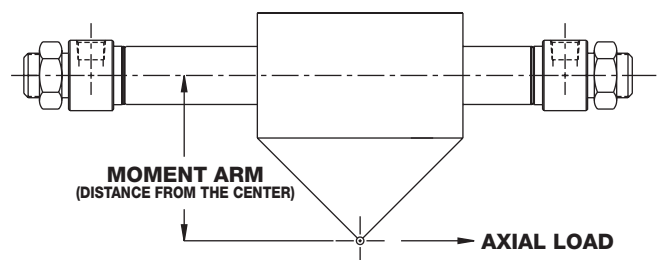
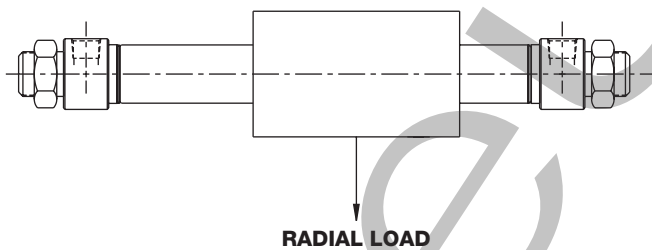

RADIAL LOAD vs STROKE LENGTH*

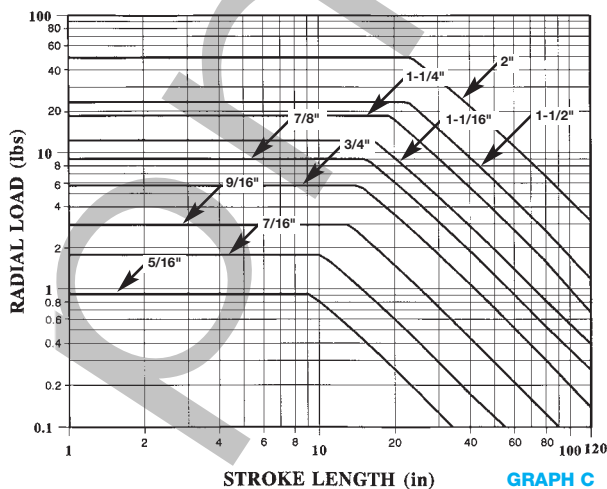

AXIAL LOAD vs MOMENT ARM

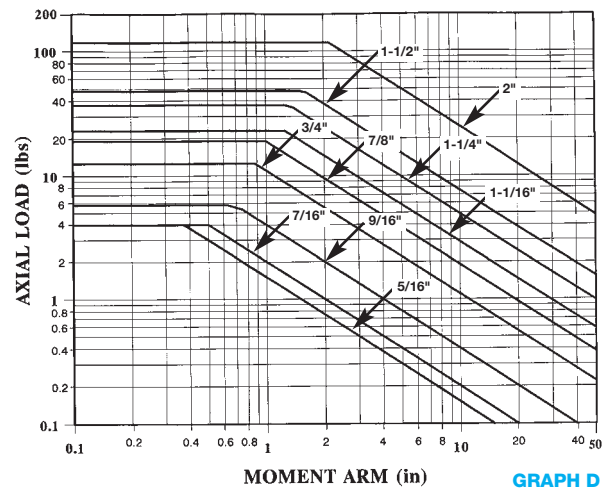

*Stud mount only. Consult factory if pivot mounted.

Ultram
Cylinders

Ultram Slide
Cylinders

Ultram Rodless
Cylinders

High Load
Ultram Cylinders

Ultram Application
Checklist

Bimba Ultram Rodless Cylinders

Velocity vs. Load for Basic Ultram Models

Note: Velocities in excess of 20 in./sec. require application review by Bimba.

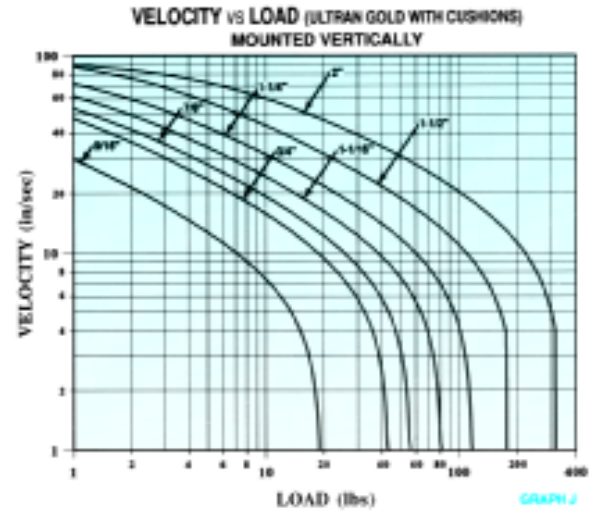
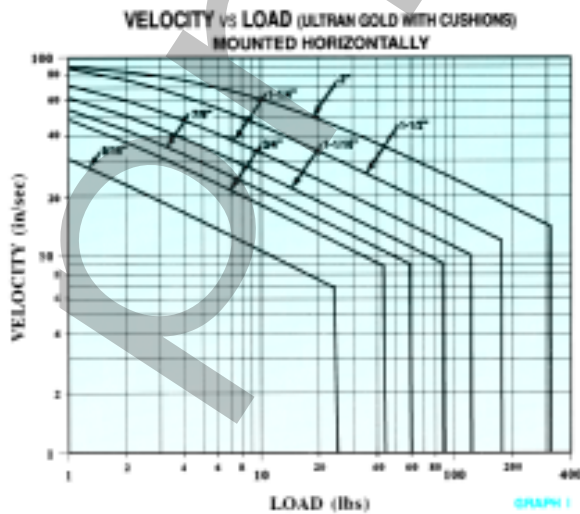
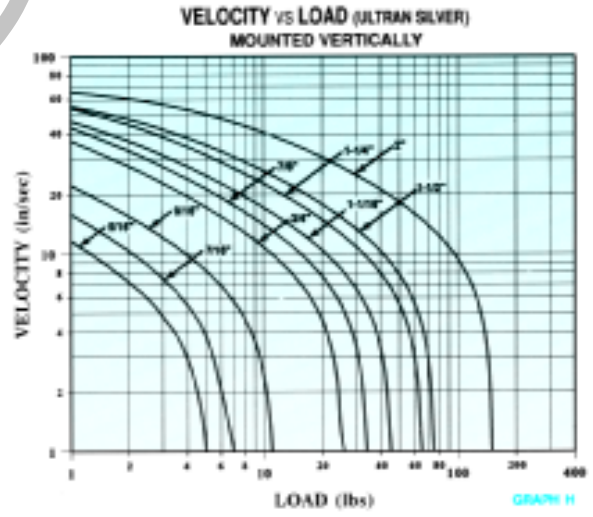
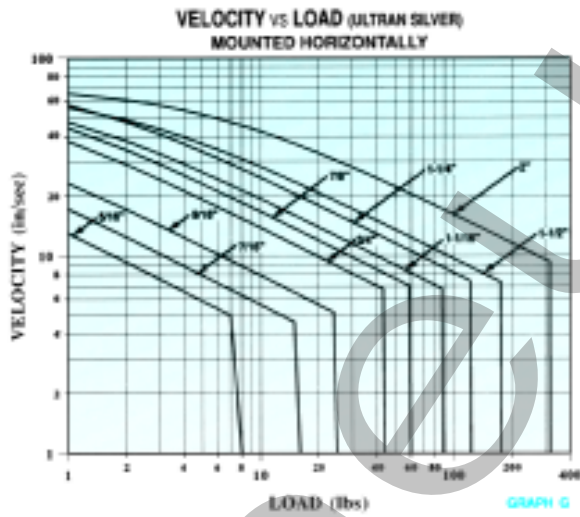
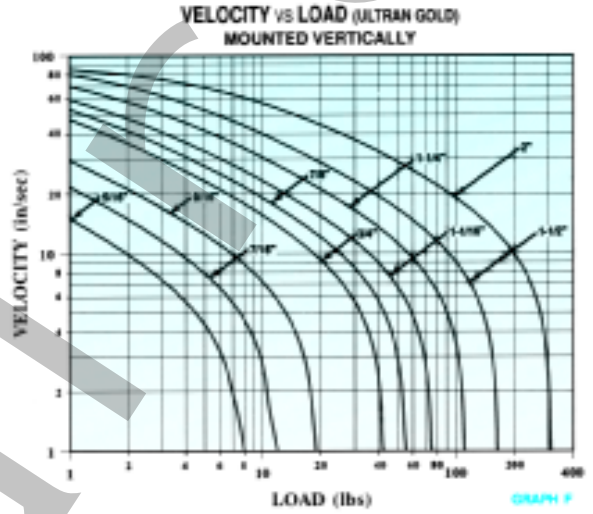
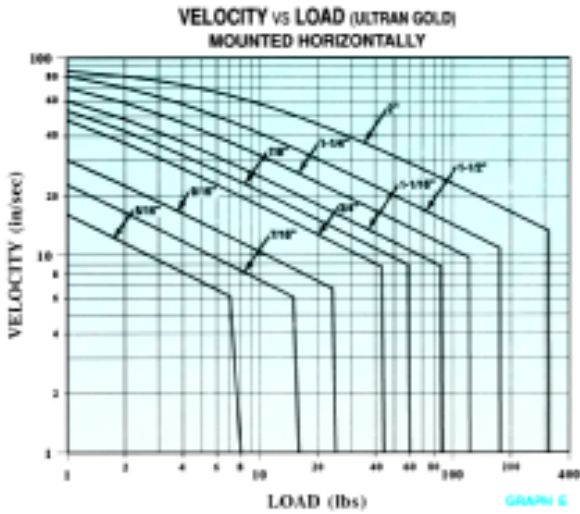

Bimba Ultram Rodless Cylinders

Velocity vs. Load for Basic Ultram Models

Note: Velocities in excess of 20 in./sec. require application review by Bimba.

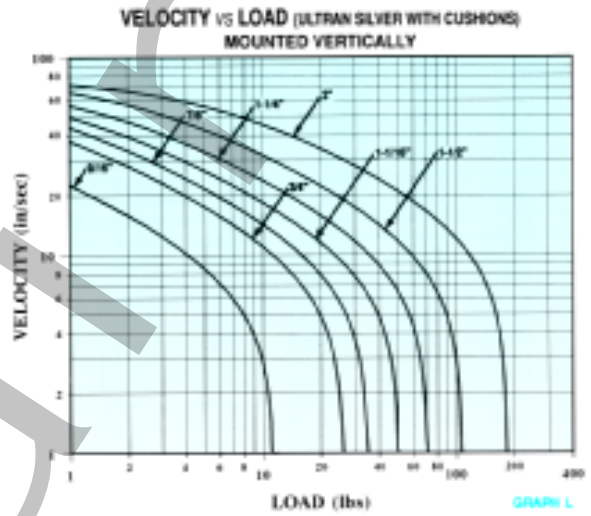
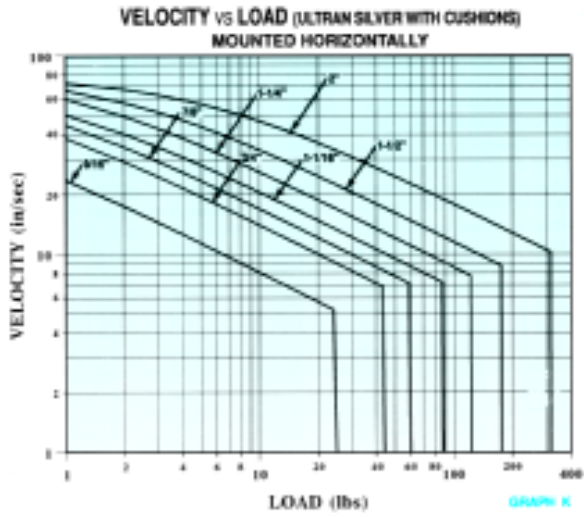

Ultram
Cylinders

Ultram Slide
Cylinders

Ultram Rodless
Cylinders

High Load
Ultram Cylinders

Ultram Application
Checklist

Bimba High Load Ultran Cylinders

Provides high load carrying capability within an Ultran Slide Cylinder. The unit incorporates a ball bearing system offering large load bearing capabilities with greater carriage precision.

ADVANTAGES

- Large load bearing capabilities.
- Greater carriage precision.
- Leak-free construction.
- Piston seals are internally lubricated for long life.
- Special rare earth magnet configura for high magnetic coupling strength:
- 304 stainless steel body and “U” cup seals for lower dynamic friction.
- Prelubricated for miles of maintenance-free travel, with easily-accessible carriage lubrication port.
- Shock absorbers to decelerate loads.
- Optional 1-inch stroke length adjustment available.
- Midstroke position sensing available. End-of-stroke sensing available for all models.
- Optional bumpers to reduce noise.
- Oil service seal option available for low pressure hydraulic service.

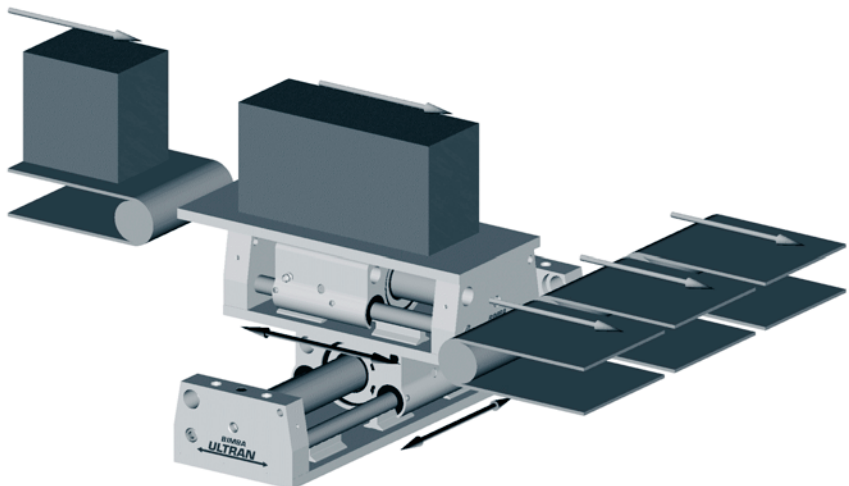
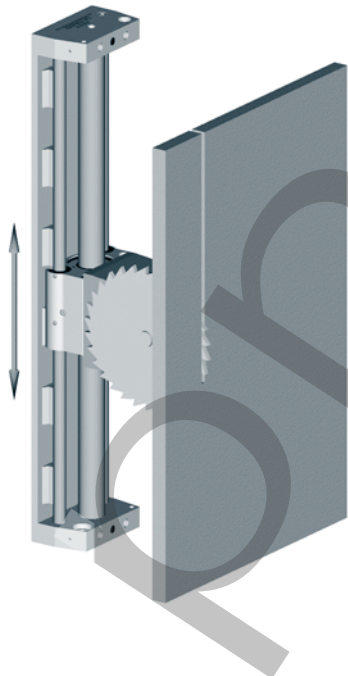
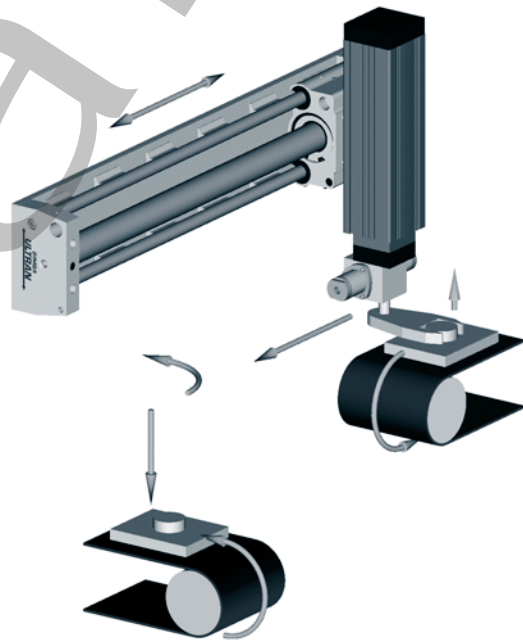
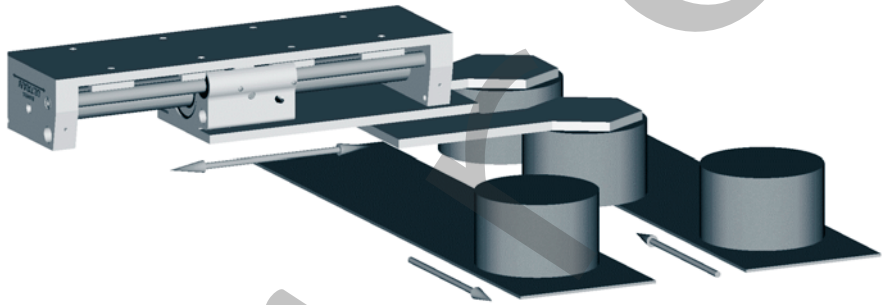

Bimba High Load Ultran Cylinders

How to Order

The model number for High Load Ultran cylinders consists of three alphanumeric clusters. These designate product type, bore size and stroke length, and options. Please refer to the charts below for an

example of model number UHL-12 25.75-A1T. This is a 1-1/4" bore, 25.75" stroke High Load Ultran rodless cylinder with stroke adjustment on one end and a track for mounting switches.

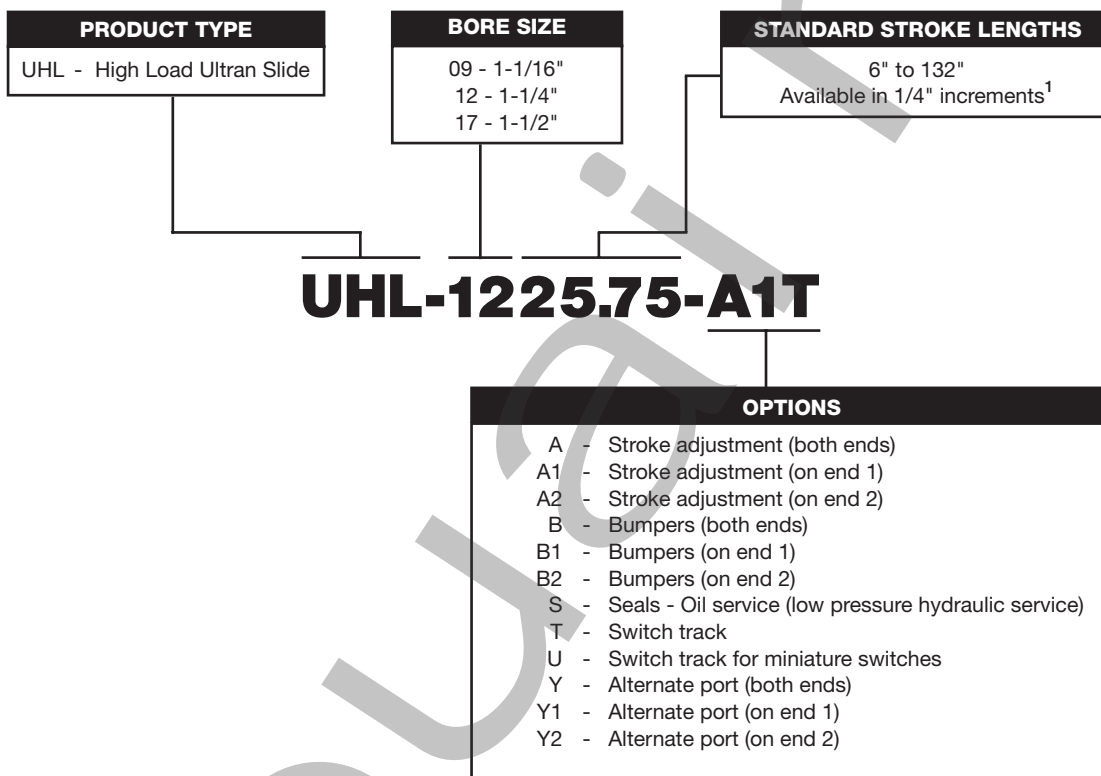

Note: All options are compatible, except bumpers (option B) and oil service seals (option S).

Dowel pin holes are standard on 1-1/16" (09) and 1-1/2" (17) bore cylinder. Not available on 1-1/4" (12) bore cylinder.

¹ *Contact your authorized Bimba distributor if smaller stroke increments are required for your application.*

Ultram
Cylinders

Ultram Slide
Cylinders

Ultram Rodless
Cylinders

High Load
Ultram Cylinders

Ultram Application
Checklist

ORDER ONLINE Bimba High Load Ultram Cylinders

Dimensions (in.)

Bore	A	B	C	D	E	F	G	H	I	J	K
1-1/16" (09)	0.500	0.706	2.500	3.500	5.000	0.375	1.750 *	1.750	1/4-20 UNC	0.375	0.750
1-1/4" (12)	0.562	0.750	2.750	3.875	5.875	0.318	2.125	1.938	1/4-20 UNC	0.500	1.000
1-1/2" (17)	0.500	0.756	3.500	4.500	6.500	0.500	2.500	2.250	5/16-18 UNC	0.520	1.000

Bore	L	M	N	O	P	Q	R	S	T	U	V
1-1/16" (09)	0.500	0.250	0.375	5/16-24 UNF	1/8 NPT	1/2-20 UNF	0.594	0.375	2.300	3.062	4.250
1-1/4" (12)	0.625	0.306	0.514	5/16-24 UNF	1/8 NPT	3/4-16 UNF	0.742	0.563	1.660	3.500	5.000
1-1/2" (17)	0.625	0.559	0.486	5/16-24 UNF	1/8 NPT	3/4-16 UNF	0.992	0.906	1.917	4.500	6.000

Bore	W	X	Y	Z	AA	BB	CC	II	DD	EE
1-1/16" (09)	0.172	0.375	1.125	1.563	1.922	2.625	2.688	#10	0.252	0.420
1-1/4" (12)	0.109	0.375	1.125	1.750	1.938	3.000	3.062	#10	—	—
1-1/2" (17)	0.140	0.375	1.281	2.000	2.109	3.500	3.562	1/4"	—	—

*Note: The 09 base plate mounting holes are 1.56" apart. Other bore sizes have carriage mounting holes and base plates mounting holes in line as shown.

Mounting Hole Calculation for 1-1/16" bore

$$JJ = \frac{KK - (\text{INT}(\frac{KK}{4}) \times 4)}{2}$$

If Result < 1.60, use:

$$JJ = \frac{KK - [(\text{INT}(\frac{KK}{4}) - 1) \times 4]}{2}$$

Where KK = (E + Stroke)
and INT is integer.

Mounting Hole Calculation for 1-1/4" and 1-1/2" bores

$$JJ = \frac{KK - (\text{INT}(\frac{KK}{4}) \times 4)}{2}$$

If Result < 1.85, use:

$$JJ = \frac{KK - [(\text{INT}(\frac{KK}{4}) - 1) \times 4]}{2}$$

Where KK = (E + Stroke)
and INT is integer.

END 1

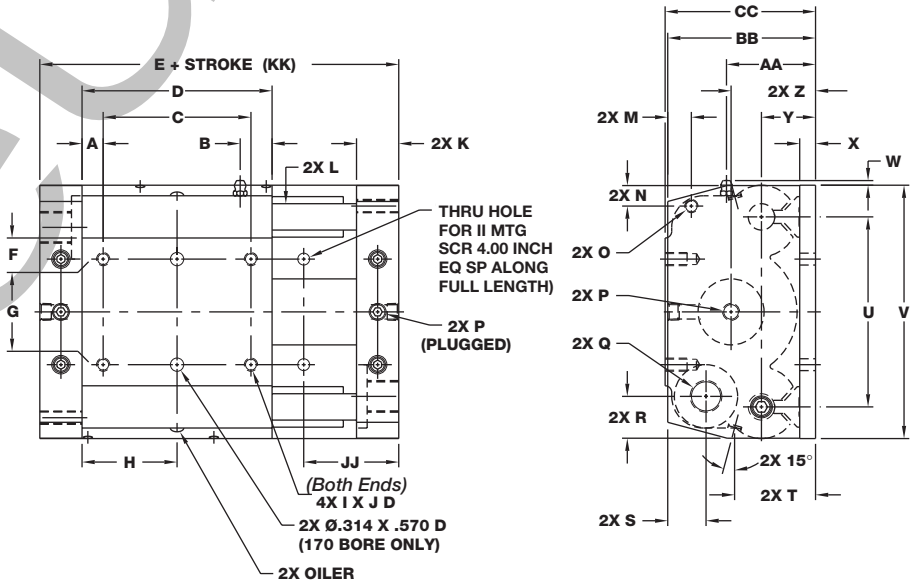

Ports

The Base Model High Load Ultram Slide offers both axial and alternate port locations. The base unit comes with flush surface plugs installed on top of the End Blocks unless the "Y" option is specified. This no charge option has the plugs installed on the side of the End Blocks.

Ultram Cylinders

Ultram Slide Cylinders

Ultram Rodless Cylinders

High Load Ultram Cylinders

Ultram Application Checklist

Bimba High Load Ultran Cylinders

Options

Shock Absorber/Stroke Adjustment (in.)

Bore	A	B	C	D	E	F
1-1/6" (09)	1.562	1/2-20 UNF	0.594	2.250	2.060	0.465
1-1/4" (12)	1.750	3/4-16 UNF	0.742	2.438	2.312	0.550
1-1/2" (17)	1.750	3/4-16 UNF	0.992	2.594	2.312	0.550

Note: Do not let the shock absorbers bottom out. The shock should not be used as a stroke adjuster. An optional stop collar is needed if stroke adjustment is required.

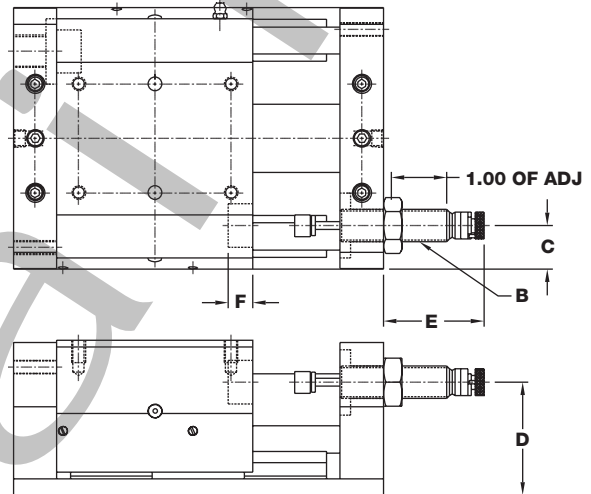
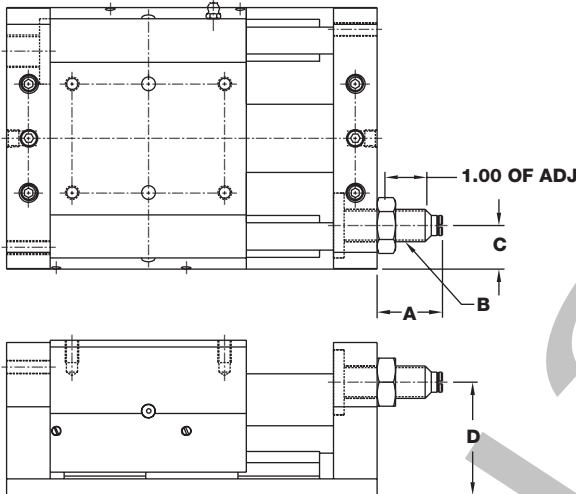

Bumper Compression

Bore	Pressure
1-1/16" (09)	80 psi
1-1/4" (12)	80 psi
1-1/2" (17)	60 psi

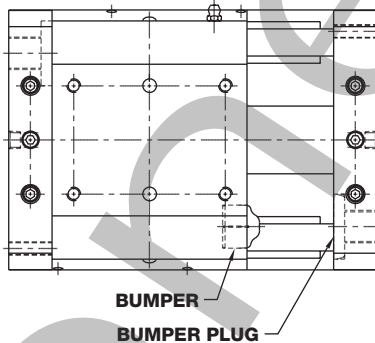

Alternate Port (in.)

Bore	G	H
1-1/16" (09)	0.375	1/8 NPT
1-1/4" (12)	0.500	1/8 NPT
1-1/2" (17)	0.500	1/8 NPT

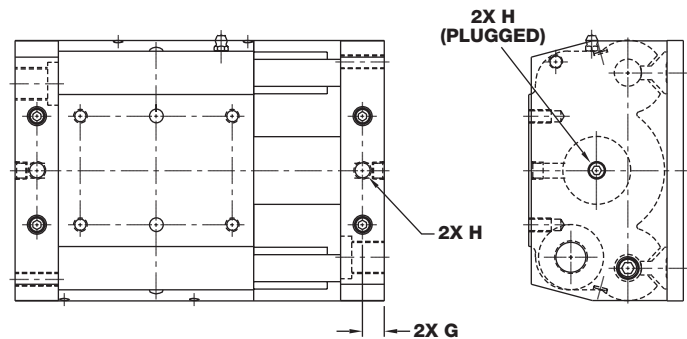

The Bumper option does not add overall length to the cylinder. However, the unit will not go full stroke until the specified pressure in table above is applied to the cylinder. If full stroke is required at a pressure less than that specified above, the stroke adjustment option may be utilized in combination with the bumper option to obtain full stroke. i.e., If 5 inches of stroke is required at 40 psi, order a 5.5 inch stroke unit with the Stroke Adjustment Option and adjust the stroke down to 5 inches.

The Base Model High Load Ultran Slide offers both axial and alternate port locations. The base unit comes with flush surface plugs installed in the top ports of the End Blocks unless the "Y" option is specified. This no charge option has the plugs installed in the End Block side ports.

Bimba High Load Ultram Cylinders

Options

Switch Track for Miniature Switches

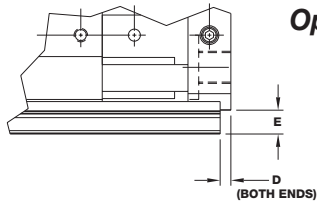

Option T

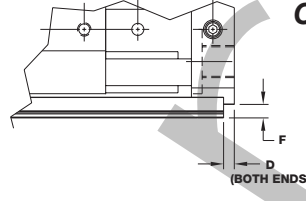
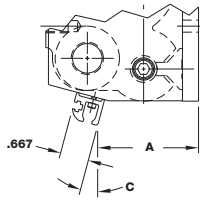

Option U

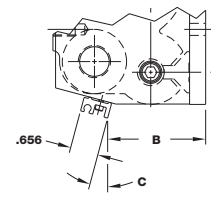

Bore	A	B	C	D	E	F
1-1/16" (09)	1.497	1.494	0°	0.125	0.531	0.272
1-1/4" (12)	1.999	1.954	10°	0.242	0.522	0.267
1-1/2" (17)	2.356	2.289	15°	0.250	0.577	0.327

Engineering Specifications

Lubrication

All Bimba High Load Ultram Slide actuators are pre-lubricated internally and externally with our special bearing grade grease. The guide shafts are pre-lubricated with a lightweight oil. The cylinder's life can be extended by providing additional lubrication with an air line mist lubricator and by lubricating the carriage every 100 miles with a high grade bearing grease. The guide shafts should be lubricated periodically with a lightweight oil. Do not over oil – there is an internal wick to retain the lightweight oil.

Repairs

The High Load Ultram Slide actuators must be returned to the factory for repairs.

Operating

Medium: Air or hydraulic

Pressure

Rating: 100 psi

Temperature

Range: 0°F to +170°F

Breakaway: Less than 25 psi

Components

Carriage	Anodized aluminum
End Block	Anodized aluminum
Guide Shaft	Case-hardened steel
Base Plate	Anodized aluminum
Guide Shaft Support	Anodized aluminum
End Block Screws	Stainless steel
Guide Shaft Screws	Black oxide carbon steel
Carriage Retaining Rings	Plated carbon steel
Body Wiper	Urethane
Guide Shaft Bearing	Ball bearings in plastic housing
Port Plug	Carbon steel
Bearing Retaining Screw	Stainless steel

Options

Bumpers (Internal & External)	Urethane
Stroke Adjuster Screw	Stainless steel
Shock Absorbers	Anodized aluminum end plates, 303 stainless steel guide rods
Bumper Plug	Anodized aluminum
Stroke Adjuster Bumper Plate	Anodized aluminum
Switch Track	Anodized aluminum

Magnetic Coupling Strength (lbs.)

Bore Size	Strength
1-1/16" (09)	127
1-1/4" (12)	190
1-1/2" (17)	270

Weights (lbs.)

Bore Size	Base Weight (0" Stroke)	Adder per 1"
1-1/16" (09)	5.43	0.23
1-1/4" (12)	7.87	0.44
1-1/2" (17)	14.1	0.45
Option Adders for 1-1/16"		
A Option Adder	0.19	N/A
A1 Option Adder	0.1	N/A
A2 Option Adder	0.1	N/A
B Option Adder	0.01	N/A
Option Adders for 1-1/4" and 1-1/2"		
A Option Adder	2.67	N/A
A1 Option Adder	1.33	N/A
A2 Option Adder	1.33	N/A
B Option Adder	0.01	N/A

ORDER
ONLINE

Bimba High Load Ultran Cylinders

Size / Application Considerations

Each bore size of the High Load Ultran Slide has specific load-carrying capabilities. Shock absorbers can extend cylinder life when used properly. See subsequent section on shock absorbers to calculate maximum allowable kinetic energy before a shock absorber is required.

Use the following procedures to determine the requirements for specific applications.

NOTE: Exceeding the recommended loads can result in improper cylinder function: piston/carriage decoupling, unacceptable deflections, etc.

1. Check the loading condition requirements and find that condition below. See sketches A and B for illustration of loading conditions.
2. Depending on the loading condition, use the appropriate chart, graph or formula to help determine maximum allowable loads and/or moment arms.

Table 1. Maximum Allowable Loads and Moments*

Bore	Maximum Load			Maximum Moment		
	Radial (lbs.)	Pull Off (lbs.)	Side (lbs.)	Axial (Ma) (in-lbs.)	Radial (Mr) (in-lbs.)	Cross (Mc) (in-lbs.)
1-1/16" (09)	1440	992	1440	1111	435	1613
1-1/4" (12)	2480	220	992	261	385	1178
1-1/2" (17)	2480	992	1984	1488	2232	2976

* Dynamic Ratings

The values shown in Table 1 are the maximum allowable loads for the load carrying system. To achieve these values, the base plate must be fully supported along its full length and the load must be equally distributed among all four bearings. For best results, your application analysis should determine maximum loading on each bearing.

Do not exceed 20 in./sec. velocity or 15 cycle/minute cycle rate; the internal piston bearings will heat up and cause sluggish motion.

Radial Load and Pull-off Load

A load applied perpendicular to both the base plate and to the direction of actuation. Load directed toward the base plate represents the maximum loading capacity of the system. Load directed away from the base plate reduces the system's load rating to approximately 40% of maximum radial loading. This is what's called the "pull-off" capacity.

In this loading condition, the maximum radial load-carrying capability is 620 pounds per bearing. The maximum "pull-off" load in the same mounting condition is 248 pounds per bearing.

Side Load

A load that is applied parallel to the base plate, but perpendicular to the direction of actuation. Depending on bore size, the maximum side load will be at least 20% less than the maximum radial loading capacity.

In this loading condition, the maximum load carrying capability is 496 pounds per bearing. Only two bearings are used to calculate the load carrying capability of the 1-1/4" bore unit.

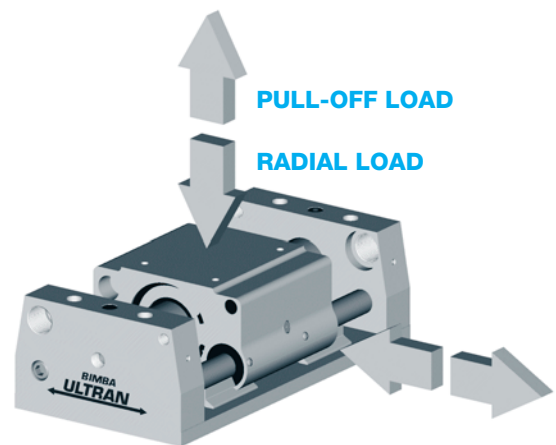

SKETCH A

Bimba High Load Ultran Cylinders

Size / Application Considerations

Radial Moment Load (M_r)

An unbalanced radial or side load applied to the system. The center of the radial load must be outside the span of the guide shafts, or the center of the side load must be at some point other than the center of the guide shafts to cause a radial moment loading condition.

Axial Moment Load (M_a)

An axial (same as the direction of actuation) load applied to the system, where the center of the load is at some point other than the center of the guide shafts. The load must also be between the span of the guide shafts to be a pure axial moment loading condition.

Cross Moment Load (M_c)

An axial load applied to the system, where the center of the load is at some point outside of the span of the guide shafts.

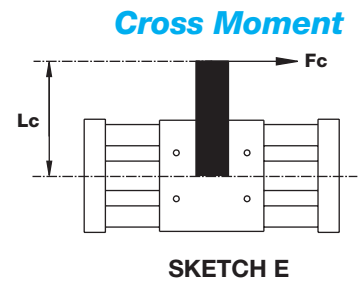
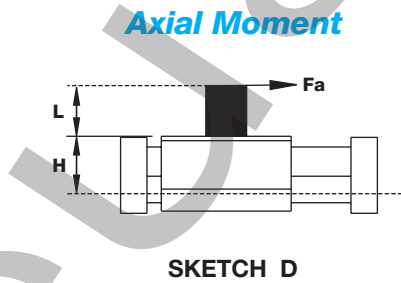
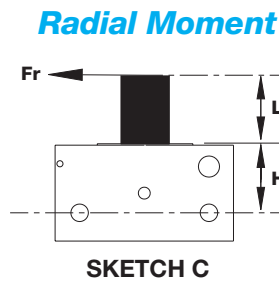
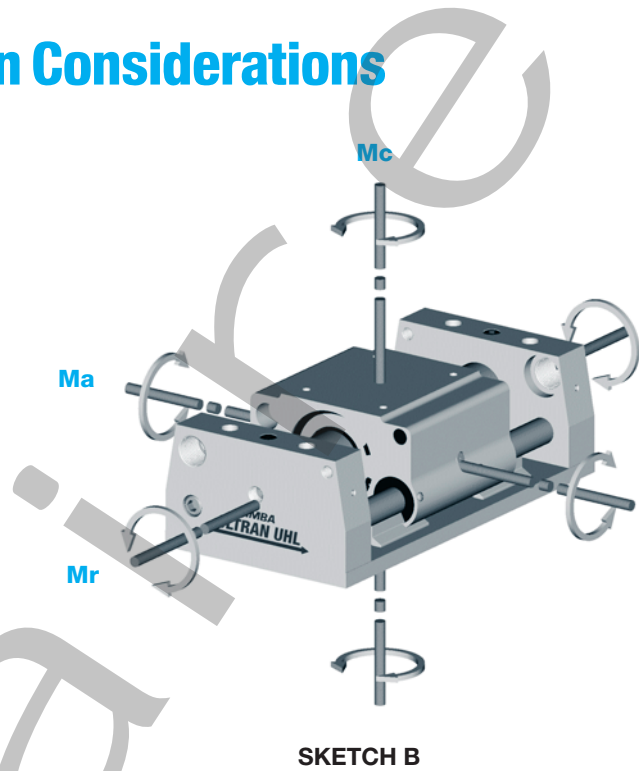

Sketches C, D, and E demonstrate how a force is applied to a moment arm to produce the moments shown in Sketch B. Use the equations below to determine the actual moments created by your application. The results of each calculated moment should be compared to the maximums listed in the table. (If the actual moments are greater than the listed maximums, then the load and moments should be re-evaluated.)

$$\text{Radial Moment} = M_r = F_r \times (L+H)$$

$$\text{Axial Moment} = M_a = F_a \times (L+H)$$

$$\text{Cross Moment} = M_c = F_c \times (L_c)$$

A High Load Ultran Slide can withstand compound moments but the maximum allowable will be determined by the total percentage of the axial, radial and cross moments. The equation below will determine the compound moment percent based on the total moments. The compound moment percent must not be greater than 100. (If the compound moment percent is greater than 100, then the load and moments should be re-evaluated.)

$$M_{\text{compound}\%} = 100 \times \left(\frac{M_r}{M_{r \text{ max}}} + \frac{M_a}{M_{a \text{ max}}} + \frac{M_c}{M_{c \text{ max}}} \right) \leq 100\%$$

ORDER ONLINE Bimba High Load Ultram Cylinders

Size / Application Considerations

Unsupported Loads

If your application does not fully support the base plate, refer to Graphs 1-3. Graph 1, "Load vs. Span" displays the maximum load allowable with a maximum 0.005" deflection.

If your application allows for greater deflections, refer to Graphs 2 and 3, "Deflection vs. Span". Use the following steps to determine resultant loads or deflections pertinent to your application.

1. If you know the length (span) that the base plate will be supported, find that span on the X-Axis of the graph. From this point, go up to the approximate location that best represents your weight or load. Across to the left from this point where it intersects the Y-Axis identifies what deflection can be expected between the supported points.
2. If you know the maximum amount of deflection that your application can tolerate, find that deflection on the Y-Axis of the graph. Once you locate the desired deflection, go across to the approximate location that best represents your weight or load. Directly under this point on the X-Axis is the recommended span length.

If your application combines radial and moment loads, or exceeds the deflections from Graphs 2 and 3, consult your authorized Bimba distributor to determine if the application is feasible.

NOTE: Velocities exceeding 20 in./sec. or 15 cycle/minute require review by Bimba.

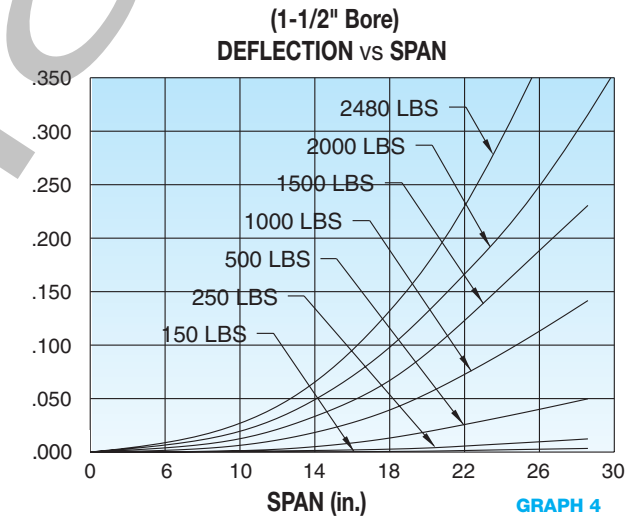
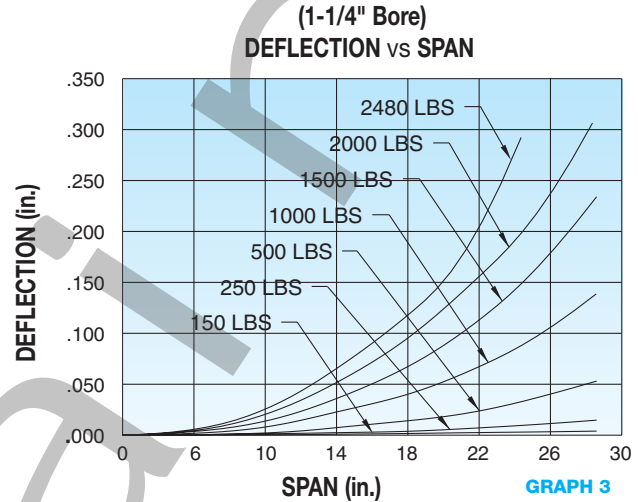
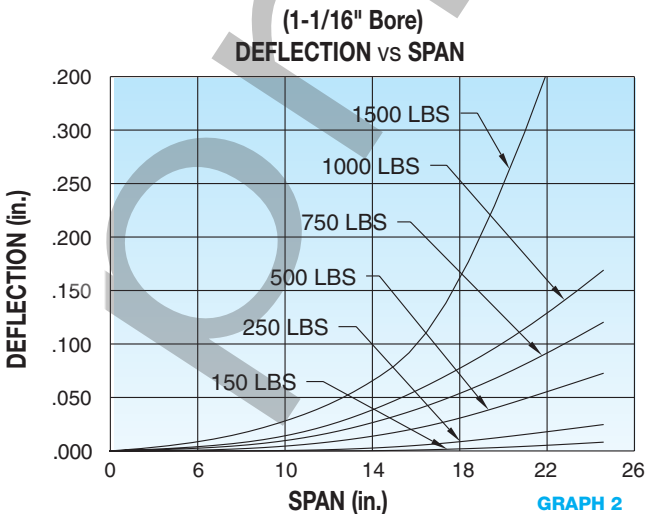
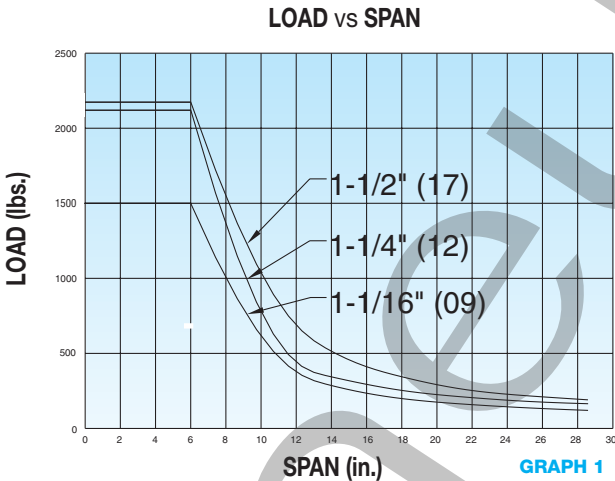

Bearing Life

The life of the ball bearing bushings are primarily affected by the amount of load it is required to carry. This can be best illustrated by Graph 4 below.

