

Modular F.R.L. Unit



Introducing our latest F.R.L. units!

Series AC



Modular F.R.L. Unit Series AC

Space-saving design

The use of compact spacer with bracket reduces the total assembling space.

Model		Reduction (mm)
New	Old	
AC10	AC1000	4
AC20	AC2000	14
AC25	AC2500	14
AC30	AC3000	14
AC40	AC4000	18
AC40-06	AC4000-06	18
AC50	AC5000	18
AC55	AC5500	18
AC60	AC6000	18

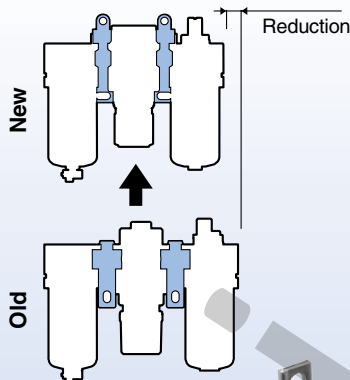

Improved visibility for lubricant drip with graduation for lubricant control

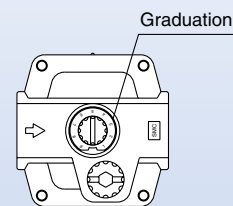

Spacer with bracket

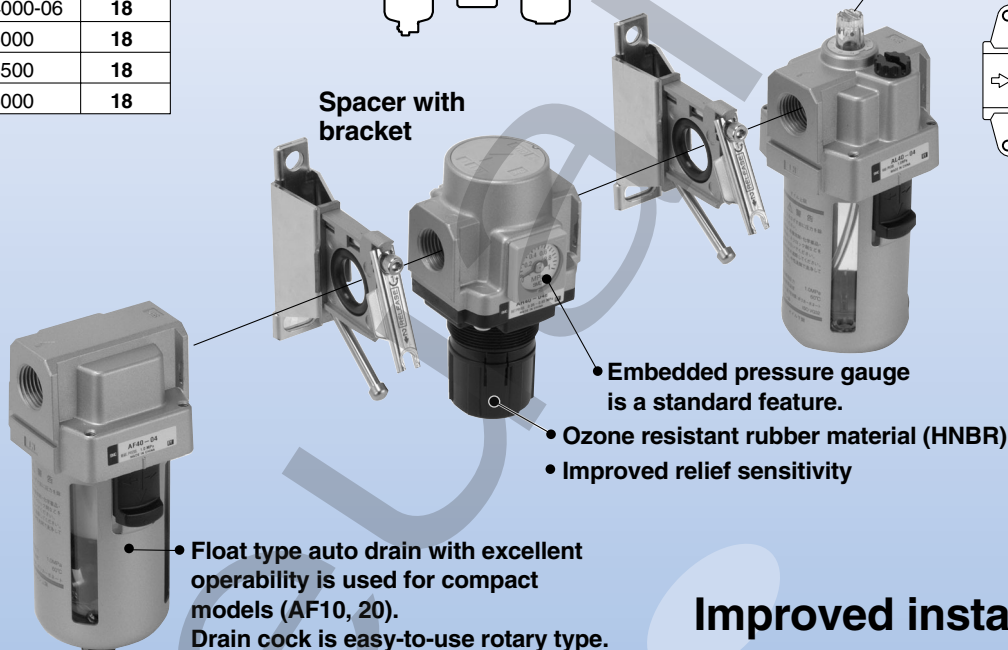

Improved installation

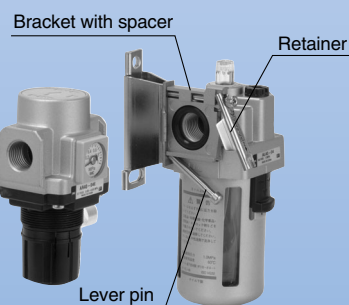

- ① Attach the component into the fitting of the spacer with bracket.
- ② Lock the lever pin into the retainer. (temporary installation)

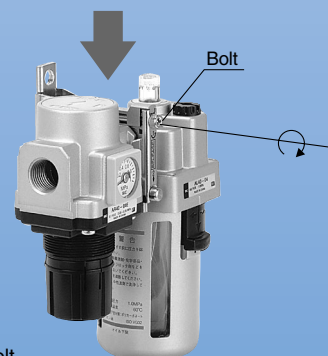

- ③ Tighten the bolt.

Knob cover

Prevents careless knob operation.



Part no.	Model
AR20P-580AS	AC20□, AR20, AR20K, AW20, AW20K, AWM20, AWD20
AR25P-580AS	AC25□, AR25, AR25K
AR30P-580AS	AC30□, AR30, AR30K, AW30, AW30K, AWM30, AWD30
AR40P-580AS	AC40□(-06), AR40(-06), AR40K(-06), AW40(-06), AW40K(-06), AWM40, AWD40

Standard Combination





Combination	Model	Port size	Component				
			Air filter AF	Regulator AR	Lubricator AL	Filter regulator AW	Mist separator AFM
	AC10	M5 x 0.8	AF10	AR10	AL10		
	AC20	1/8, 1/4	AF20	AR20	AL20		
	AC25	1/4, 3/8	AF30	AR25	AL30		
	AC30	1/4, 3/8	AF30	AR30	AL30		
	AC40	1/4, 3/8, 1/2	AF40	AR40	AL40		
	AC40-06	3/4	AF40-06	AR40-06	AL40-06		
	AC50	3/4, 1	AF50	AR50	AL50		
	AC55	1	AF60	AR50	AL60		
	AC60	1	AF60	AR60	AL60		
	AC10A	M5 x 0.8			AL10	AW10	
	AC20A	1/8, 1/4			AL20	AW20	
	AC30A	1/4, 3/8			AL30	AW30	
	AC40A	1/4, 3/8, 1/2			AL40	AW40	
	AC40A-06	3/4			AL40-06	AW40-06	
	AC10B	M5 x 0.8	AF10	AR10			
	AC20B	1/8, 1/4	AF20	AR20			
	AC25B	1/4, 3/8	AF30	AR25			
	AC30B	1/4, 3/8	AF30	AR30			
	AC40B	1/4, 3/8, 1/2	AF40	AR40			
	AC40B-06	3/4	AF40-06	AR40-06			
	AC50B	3/4, 1	AF50	AR50			
	AC55B	1	AF60	AR50			
	AC60B	1	AF60	AR60			
	AC20C	1/8, 1/4	AF20	AR20			AFM20
	AC25C	1/4, 3/8	AF30	AR25			AFM30
	AC30C	1/4, 3/8	AF30	AR30			AFM30
	AC40C	1/4, 3/8, 1/2	AF40	AR40			AFM40
	AC40C-06	3/4	AF40-06	AR40-06			AFM40-06
	AC20D	1/8, 1/4				AW20	AFM20
	AC30D	1/4, 3/8				AW30	AFM30
	AC40D	1/4, 3/8, 1/2				AW40	AFM40
	AC40D-06	3/4				AW40-06	AFM40-06

Table of Contents

■ F.R.L. Unit

Air Filter + Regulator + Lubricator
 AC10 to 60 Page 1
 Filter Regulator + Lubricator
 AC10A to 40A Page 5
 Air Filter + Regulator
 AC10B to 60B Page 7
 Air Filter + Mist Separator + Regulator
 AC20C to 40C Page 9
 Filter Regulator + Mist separator
 AC20D to 40D Page 11
 Attachment Specifications Page 13
 Spacers and Brackets: Accessories Page 18
 Made to Order Specifications Page 20

■ Modular Type Air Filter

Air Filter
 AF10 to 60 Page 23
 Made to Order Specifications Page 28
 Mist Separator
 AFM20 to 40 Page 29
 Micro-Mist Separator
 AFD20 to 40 Page 32

■ Modular Type Regulator

Regulator
 AR10 to 60 Page 36
 Made to Order Specifications Page 41
 Regulator with Back Flow Mechanism
 AR20K to 60K Page 43

■ Modular Type Lubricator

Lubricator
 AL10 to 60 Page 50

■ Modular Type Filter Regulator

Filter Regulator
 AW10 to 40 Page 56
 Made to Order Specifications Page 61
 Filter Regulator with Back Flow Mechanism
 AW20K to 40K Page 63
 Mist Separator Regulator
 AWM20 to 40 Page 67
 Micro-Mist Separator Regulator
 AWD20 to 40 Page 71

Simple Specials System

A system designed to respond quickly and easily to your special ordering needs.

Simple Specials Order Specifications

- ① Modular/Attachment combination & Combination order
Attachment symbols:
Piping adapter: E□0
Pressure switch: IS1000□
Check valve: AKM
Cross interface: Y□4
3-port valve for releasing residual pressure:
VHS□□
- ② Modular products, Combination of special order numbers & Combination order
Special orders for AF, AR, AL, AW, AF□, AW□

Simple Specials System

Short lead times

This system enables us to respond to your special needs, such as additional machining, accessory assembly, or modular unit, and deliver such special products as quickly as standard products.

Repeat orders

As soon as we receive a Simple Special part number from your previous order, we will process the order, manufacture the product, and deliver it to you.

Please contact P/A for further details on the Simple Specials System.

How to Order

AC 30 A F 03 DE KV 12R

F.R.L. unit

Body size

10	20	25	30	40	50	55	60
----	----	----	----	----	----	----	----

Model combination

Symbol	Combination				
	Air filter	Regulator	Lubricator	Filter regulator	Mist separator
Nil	①	②	③	—	—
A	—	—	②	①	—
B	①	②	—	—	—
C	①	③	—	—	②
D	—	—	—	①	②

* The number inside ○ indicates the combination order counted from the inlet side.

Thread type

Nil	Metric system thread (M5)
	Rc
N Note 1)	NPT
F Note 2)	G

Note 1) Drain guide is NPT1/4 (applicable to AC25 to 60), and the exhaust port for auto drain comes with ø3/8" One-touch fitting (applicable to AC25 to 60).

Note 2) Drain guide is G1/4 (applicable to AC25 to 60).

Port size

Symbol	Port size	Body size							
		10	20	25	30	40	50	55	60
M5	M5	●	—	—	—	—	—	—	—
01	1/8	—	●	—	—	—	—	—	—
02	1/4	—	●	●	●	—	—	—	—
03	3/8	—	—	●	●	●	—	—	—
04	1/2	—	—	—	—	●	—	—	—
06	3/4	—	—	—	—	●	●	—	—
10	1	—	—	—	—	—	●	●	●

Accessories

Symbol	Description	Applicable model
Nil	—	—
C	Float type auto drain (N.C.) ^{Note 1)}	AC10□ to 60□
D	Float type auto drain (N.O.) ^{Note 1)}	AC25□ to 60□
E	With square embedded type pressure gauge (with limit indicator)	AC20□ to 60□
G ^{Note 2)}	With round pressure gauge (without limit indicator)	AC10□
	With round pressure gauge (with limit indicator)	AC20□ to 60□

Note 1) Applicable tube O.D for auto drain connection should be ø3/8" in case NPT thread port is chosen.

Note 2) Mounting thread for pressure gauge:
1/16 for AC10; 1/8 for AC20 to 30; 1/4 for AC40 to 60
Pressure gauge is not mounted and is supplied loose at the time of shipment.

Optional specifications

Symbol	Description	Applicable model
1 ^{Note 1)}	0.02 to 0.2MPa setting	AC10□ to 60□
2	Metal bowl	AC10□ to 60□
3	Lubricator with drain cock	AC10□ to 60□
6	Nylon bowl	AC10□ to 60□
8	Metal bowl with level gauge	AC25□ to 60□
C	With bowl guard	AC25□ to 60□
J ^{Note 2)}	Drain guide 1/4	AC10□ to 60□
N	Non-relieving type	AC10□ to 60□
R	Flow direction: Right to left	AC10□ to 60□
W	Drain cock with barb fitting: ø6 x ø4 nylon tube	AC25□ to 60□
Z ^{Note 3)}	Name plate, caution plate for bowl, and pressure gauge in imperial units (PSI, °F)	AC10□ to 60□

* When more than one specification is required, indicate in ascending alphanumeric order.

Note 1) The only difference from the standard specifications is the adjusting spring for the regulator. It does not restrict the setting of 0.2MPa or more.

Note 2) Without a valve function.

Note 3) For thread types M5 and NPT. This product is for overseas use only according to the new Measurement Law. (The SI unit type is provided for use in Japan.) Pressure switch comes with a dual unit scale in SI (MPa) and imperial (PSI) units.

Attachments

Symbol	Description	Attachment mounting position	Applicable model	Port size for intermediate air release
Nil	None	—	—	—
K	Check valve	AF + AR + [K] + AL	AC20 to 40	AC20□: 1/8 AC25□: 1/4 AC30□: 1/4 AC40□: 3/8
		AW + [K] + AL	AC20A to 40A	
S	Pressure switch	AF + AR + [S] + AL	AC20 to 60	—
		AW + [S] + AL	AC20A to 40A	
		AF + [S] + AR	AC20B to 60B	
		AF + AFM + [S] + AR	AC20C to 40C	
		AW + [S] + AFM	AC20D to 40D	
T	T-interface	AF + [T] + AR + AL	AC10 to 60	AC10□: M5 x 0.8 AC20□: 1/8 AC25□: 1/4 AC30□: 1/4 AC40□: 3/8 AC50□: 3/8 AC55□: 1/2 AC60□: 1/2
		AF + [T] + AR	AC10B to 60B	
		AF + AFM + [T] + AR	AC20C to 40C	
V	3-port valve for residual pressure release	AF + AR + AL + [V]	AC20 to 50	—
		AW + AL + [V]	AC20A to 40A	
		AF + AR + [V]	AC20B to 50B	
		AF + AFM + AR + [V]	AC20C to 40C	
		AW + AFM + [V]	AC20D to 40D	

* When more than one attachment is required, order in alphabetical order.

* Piping adapter, pressure switch with piping adapter, and cross interface need to be ordered separately.

* Contact P/A when using a pressure switch and T-interface together for AC□B.

* The bracket position varies depending on the T-interface or pressure switch mounting.

Refer to the table on page 19 for standard bracket position.







Series AC

Accessory/Optional Specifications Combination

⊙: Combination available □: Combination not available ○: Varies depending on the model △: Available only with NPT thread

Accessory/ Optional specifications	Combination Symbol	Accessories													Optional specifications													F.R.L. unit applicable models											
		C	D	E	G	1	2	3	6	8	C	J	N	R	W	Z	AC10	AC10B	AC20	AC20B	AC20C	AC20D	AC25	AC25B	AC25C	AC30 to AC60	AC30A	AC30A to AC40A	AC30B to AC60B	AC30C	AC30C to AC40C	AC30D	AC30D to AC40D						
		AC10A	AC10B	AC20A	AC20B	AC20C	AC20D	AC25	AC25B	AC25C	AC30	AC30A	AC30A to AC40A	AC30B	AC30B to AC60B	AC30C	AC30C to AC40C	AC30D	AC30D to AC40D																				
Accessories	Float type auto drain (N.C.)	C	□	○	⊙	⊙	⊙	⊙	⊙	○	○	○	○	○	△	⊙	⊙	⊙	⊙	⊙	⊙	⊙	⊙	⊙	⊙	⊙	⊙	⊙	⊙	⊙	⊙	⊙	⊙						
	Float type auto drain (N.O.)	D	□	○	⊙	⊙	⊙	⊙	⊙	○	○	○	○	○	△	⊙	⊙	⊙	⊙	⊙	⊙	⊙	⊙	⊙	⊙	⊙	⊙	⊙	⊙	⊙	⊙	⊙	⊙						
	Square embedded type pressure gauge	E	⊙	○	□	⊙	⊙	⊙	⊙	○	○	○	○	○	△	⊙	⊙	⊙	⊙	⊙	⊙	⊙	⊙	⊙	⊙	⊙	⊙	⊙	⊙	⊙	⊙	⊙	⊙						
	Round pressure gauge	G	⊙	⊙	□	⊙	⊙	⊙	⊙	○	○	○	○	○	△	⊙	⊙	⊙	⊙	⊙	⊙	⊙	⊙	⊙	⊙	⊙	⊙	⊙	⊙	⊙	⊙	⊙	⊙						
Optional specifications	0.02 to 0.2MPa setting	-1	⊙	⊙	○	⊙	⊙	⊙	○	○	○	○	○	○	△	⊙	⊙	⊙	⊙	⊙	⊙	⊙	⊙	⊙	⊙	⊙	⊙	⊙	⊙	⊙	⊙	⊙							
	Metal bowl	-2	⊙	⊙	○	⊙	⊙	⊙	○	○	○	○	○	○	△	⊙	⊙	⊙	⊙	⊙	⊙	⊙	⊙	⊙	⊙	⊙	⊙	⊙	⊙	⊙	⊙	⊙							
	Lubricator with drain cock	-3	⊙	⊙	○	⊙	⊙	⊙	○	○	○	○	○	○	△	⊙	⊙	⊙	⊙	⊙	⊙	⊙	⊙	⊙	⊙	⊙	⊙	⊙	⊙	⊙	⊙	⊙	⊙						
	Nylon bowl	-6	⊙	⊙	○	⊙	⊙	⊙	○	○	○	○	○	○	△	⊙	⊙	⊙	⊙	⊙	⊙	⊙	⊙	⊙	⊙	⊙	⊙	⊙	⊙	⊙	⊙	⊙	⊙						
	Metal bowl with level gauge	-8	⊙	⊙	○	⊙	⊙	⊙	○	○	○	○	○	○	△	⊙	⊙	⊙	⊙	⊙	⊙	⊙	⊙	⊙	⊙	⊙	⊙	⊙	⊙	⊙	⊙	⊙	⊙						
	With bowl guard	-C	⊙	□	○	⊙	⊙	⊙	○	○	○	○	○	○	△	⊙	⊙	⊙	⊙	⊙	⊙	⊙	⊙	⊙	⊙	⊙	⊙	⊙	⊙	⊙	⊙	⊙	⊙						
	Drain guide 1/4	-J	□	○	⊙	⊙	⊙	⊙	○	○	○	○	○	○	△	⊙	⊙	⊙	⊙	⊙	⊙	⊙	⊙	⊙	⊙	⊙	⊙	⊙	⊙	⊙	⊙	⊙	⊙						
	Non-relieving type	-N	⊙	⊙	○	⊙	⊙	⊙	○	○	○	○	○	○	△	⊙	⊙	⊙	⊙	⊙	⊙	⊙	⊙	⊙	⊙	⊙	⊙	⊙	⊙	⊙	⊙	⊙	⊙						
	Flow direction: Right to left	-R	⊙	⊙	○	⊙	⊙	⊙	○	○	○	○	○	○	△	⊙	⊙	⊙	⊙	⊙	⊙	⊙	⊙	⊙	⊙	⊙	⊙	⊙	⊙	⊙	⊙	⊙	⊙						
	Drain cock with barb fitting: ø6 x ø4 nylon tube	-W	□	○	⊙	⊙	⊙	⊙	○	○	○	○	○	○	△	⊙	⊙	⊙	⊙	⊙	⊙	⊙	⊙	⊙	⊙	⊙	⊙	⊙	⊙	⊙	⊙	⊙	⊙						
	Name plate, caution plate for bowl, and pressure gauge in imperial units (PSI, °F)	-Z	△	△	△	△	△	△	△	△	△	△	△	△	△	△	△	△	△	△	△	△	△	△	△	△	△	△	△	△	△	△	△	△					

Attachments

	Port size	Function	
Piping adapter	M5 x 0.8 1/8, 1/4, 3/8, 1/2, 3/4, 1	Allows installation/removal of the component without removing the piping.	 Page 13
T-interface	M5 x 0.8 1/8, 1/4, 3/8, 1/2	Redirects the air flow.	 Page 13
Pressure switch with piping adapter	1/8, 1/4, 3/8, 1/2, 3/4	Compact switch and piping adapter integrated into one piece.	 Page 14
Check valve	1/8, 1/4, 3/8	Prevents back flow from lubricator.	 Page 15
Pressure switch	—	Compact switch	 Page 16
Cross interface	M5 x 0.8 1/8, 1/4, 3/8, 1/2	Allows piping in all 4 directions.	 Page 17
3-port valve for residual pressure release	1/8, 1/4, 3/8, 1/2, 3/4, 1	Releases residual pressure in lines.	 Page 17

Attachment Accessories
Refer to pages 18 and 19 for interfaces and brackets.

Made to Order specifications
Refer to page 20 for details.

F.R.L. Unit **Air Filter + Regulator + Lubricator**

AC10 to 60



AC20



AC40

JIS symbol

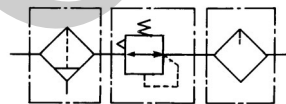

Air filter Regulator Lubricator

Standard Specifications

Model	AC10	AC20	AC25	AC30	AC40	AC40-06	AC50	AC55	AC60	
Component	Air filter	AF10	AF20	AF30	AF30	AF40	AF40-06	AF50	AF60	AF60
	Regulator	AR10	AR20	AR25	AR30	AR40	AR40-06	AR50	AR50	AR60
	Lubricator	AL10	AL20	AL30	AL30	AL40	AL40-06	AL50	AL60	AL60
Port sizes	M5 x 0.8	1/8 1/4	1/4 3/8	1/4 3/8	1/4 3/8 1/2	3/4	3/4 1	1	1	1
Pressure gauge port size ^{Note 1)}	1/16	1/8	1/8	1/8	1/4	1/4	1/4	1/4	1/4	1/4
Fluid	Air									
Proof pressure	1.5MPa									
Max. operating pressure	1.0MPa									
Set pressure range	0.05 to 0.7MPa	0.05 to 0.85MPa								
Relief pressure	Set pressure + 0.05MPa ^{Note 2)} [at relief flow rate of 0.1L/min (ANR)]									
Ambient and fluid temperature	-5 to 60°C (with no freezing)									
Nominal filtration rating	5µm									
Recommended lubricant	Class 1 turbine oil (ISO VG32)									
Bowl material	Polycarbonate									
Bowl guard	—	Option								Standard
Regulator construction	Relieving type									
Weight (kg)	0.27	0.73	0.91	1.00	1.74	1.95	4.17	4.25	4.34	



Note 1) Pressure gauge connection threads are not required for F.R.L. unit with a square embedded type pressure gauge (AC20 to AC60).

Note 2) Not applicable to AC10.

Attachment/Accessory Part No.

Description	Model	Part no.												
		AC10	AC20	AC25	AC30	AC40	AC40-06	AC50	AC55	AC60				
Accessories	Pressure gauge ^{Note 1)}	1.0MPa	Round	G-27-10-R1	G36-10-□01	G36-10-□01	G36-10-□01	G46-10-□02	G46-10-□02	G46-10-□02	G46-10-□02	G46-10-□02	G46-10-□02	
		0.2MPa	Round	G-27-10-R1 ^{Note 3)}	G36-2-□01	G36-2-□01	G36-2-□01	G46-2-□02	G46-2-□02	G46-2-□02	G46-2-□02	G46-2-□02	G46-2-□02	G46-2-□02
	Float type auto drain ^{Note 4)}	N.O.	—	—	AD38	AD38N ^{Note 7)}	AD38	AD38N ^{Note 7)}	AD48	AD48N ^{Note 7)}	AD48	AD48N ^{Note 7)}	AD48	AD48N ^{Note 7)}
		N.C.	AD17	AD27	AD37	AD37N ^{Note 7)}	AD37	AD37N ^{Note 7)}	AD47	AD47N ^{Note 7)}	AD47	AD47N ^{Note 7)}	AD47	AD47N ^{Note 7)}
Spacer		Y100	Y200	Y300	Y300	Y400	Y500	Y600	Y600	Y600	Y600	Y600		
Check valve ^{Note 5)}		—	AKM2000-□01 □02	AKM3000-□01 □02	AKM3000-□01 □02	AKM4000-□02 □03	—	—	—	—	—	—		
Pressure switch ^{Note 6)}		—	IS1000M-20	IS1000M-30	IS1000M-30	IS1000M-40	IS1000M-50	IS1000M-60	IS1000M-60	IS1000M-60	IS1000M-60	IS1000M-60		
T-interface ^{Note 5)}		Y110-M5	Y210-□01 □02	Y310-□01 □02	Y310-□01 □02	Y410-□02 □03	Y510-□02 □03	Y610-□03 □04	Y610-□03 □04	Y610-□03 □04	Y610-□03 □04	Y610-□03 □04		
3-port valve for residual pressure release ^{Note 6)}		—	VHS20-□01 □02	VHS30-□02 □03	VHS30-□02 □03	VHS40-□02 □03 □04	VHS40-□06 □10	VHS50-□06 □10	—	—	—	—		
Piping adapter ^{Note 6)}		E100-M5	E200-□01 □02 □03	E300-□02 □03 □04	E300-□02 □03 □04	E400-□02 □03 □04	E500-□06	E600-□06 □10	E600-□06 □10	E600-□06 □10	E600-□06 □10	E600-□06 □10		
Pressure switch with piping adapter ^{Note 6)}		—	IS1000E-20-□01 □02 □03	IS1000E-30-□02 □03 □04	IS1000E-30-□02 □03 □04	IS1000E-40-□02 □03 □04 □06	—	—	—	—	—	—		
Cross interface ^{Note 6)}		Y14-M5	Y24-□01 □02	Y34-□01 □02	Y34-□01 □02	Y44-□02 □03	Y54-□03 □04	—	—	—	—	—		



Note 1) □ in part numbers for a round pressure gauge indicates a type of connection thread. No indication is necessary for R; however, indicate N for NPT. Contact P/A regarding the connection thread NPT and pressure gauge supply for PSI unit specifications.

Note 2) Includes one O-ring and 2 mounting screws.

Note 3) For 1.0MPa.

Note 4) Minimum operating pressure: N.O. type-0.1MPa; N.C. type-0.15MPa (AD17/27).

Note 5) For F.R.L. units, port sizes not in () are for standard application.

Note 6) Separate interfaces are required for modular unit.

Note 7) When "N" is specified in the end of part number of auto drain, applicable tube O.D should be ø3/8".

Flow Characteristics (Representative values)

Condition: Inlet pressure 0.7MPa

AC10 M5 x 0.8

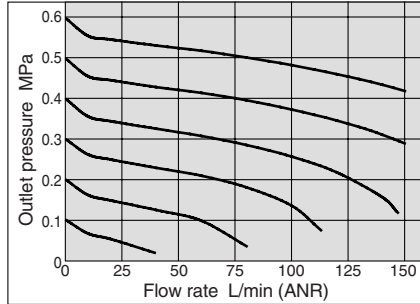

AC40-06 Rc 3/4

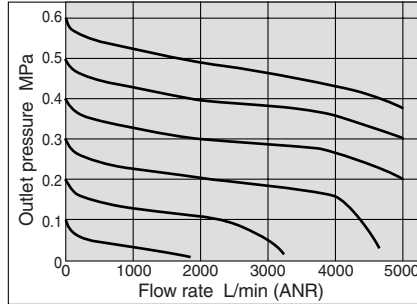

AC20 Rc 1/4

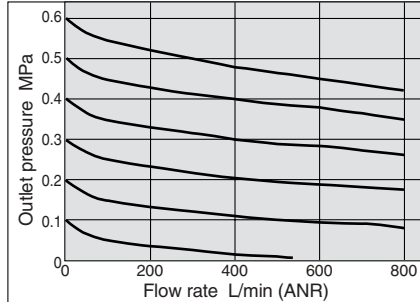

AC50 Rc 1

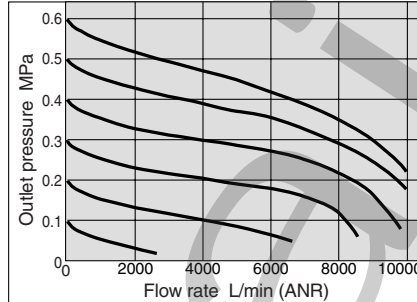

AC25 Rc 3/8

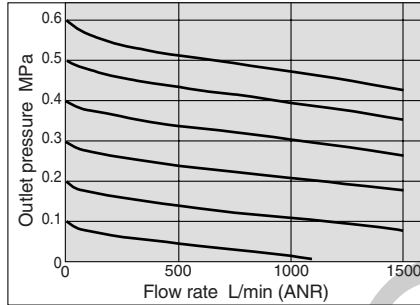

AC55 Rc 1

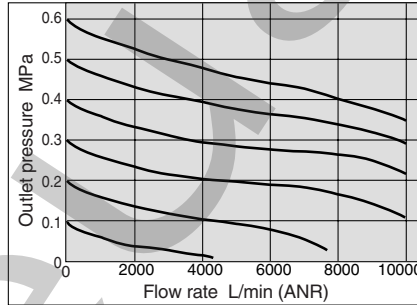

AC30 Rc 3/8

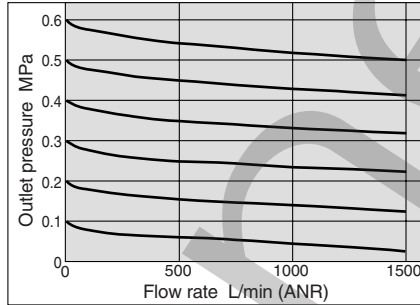

AC60 Rc 1

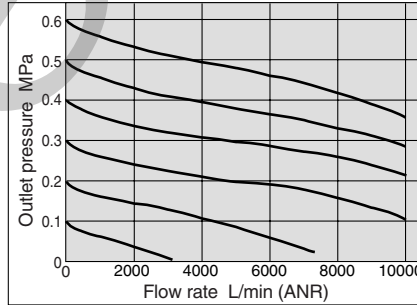

AC40 Rc 1/2

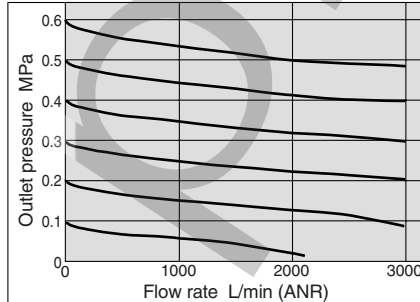

Selection

Warning

1. Float type auto drain

Operate under the following conditions to avoid malfunction.

<N.O. type>

- Operating compressor: 0.75kW [100L/min (ANR)] or more.

When using 2 or more auto drains, multiply the value above by the number of auto drains to find the capacity of the compressors you will need.

For example, when using 2 auto drains, 1.5kW [200L/min (ANR)] of the compressor capacity is required.

- Operating pressure: 0.1MPa or more.

<N.C. type>

- Operating pressure for AD17, AD27: 0.1MPa or more.

- Operating pressure for AD37, AD47: 0.15MPa or more.

2. Use a regulator or filter regulator with a back flow mechanism when mounting a 3-port valve for residual pressure release on the IN side to ensure the release of the residual pressure. Otherwise, residual pressure will not be fully released.

Caution

1. When releasing air at the intermediate position using a T-interface on the inlet side of the lubricator, lubricant may back flow. Therefore, releasing air that does not contain traces of lubricant is not possible.

To release air that does not contain traces of lubricant, use a check valve (Series AKM) on the inlet side of the lubricator to prevent a back flow of the lubricant.

2. Mounting a 3-port valve for residual pressure release on the IN side of the lubricator can cause lubricant to back flow. Take measures to prevent lubricant from splashing by installing a filter on the EXH port.

3. An F.R.L. unit shipped from the plant has its model number labeled. However, components that are combined together during the distribution process do not have a label on them.

4. Contact P/A when mounting a pressure switch, T-interface, or filter regulator on the OUT side of the 3-port valve for residual pressure release.

Specific Product Precautions

Mounting and Adjustment

Caution

1. A knob cover is available to prevent careless operation of the knob. Refer to Features 1 for details.

Piping

Warning

1. When mounting a check valve, make sure the arrow (IN side) points in the correct direction of air flow.

Air Supply

Caution

1. Use an air filter with 5µm or less filtration rating on the inlet side of the valve to avoid any damage to the seat caused by dust when mounting a 3-port valve for residual pressure release on the inlet side.

AC10 to 60

Pressure Characteristics (Representative values)

Conditions:
 Inlet pressure 0.7MPa
 Outlet pressure 0.2MPa
 Flow rate 20L/min (ANR)

AC10

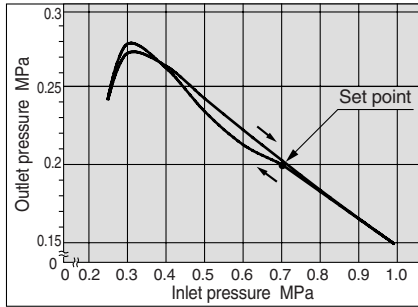

AC40-06

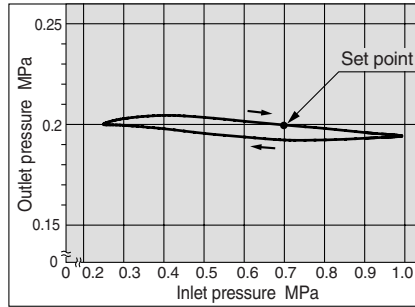

AC20

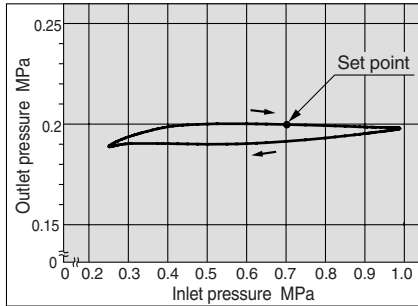

AC50

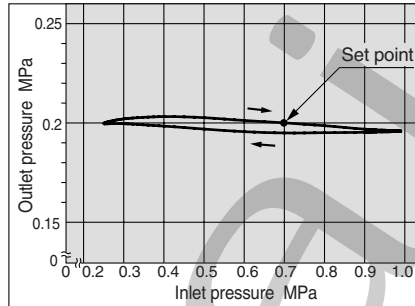

AC25

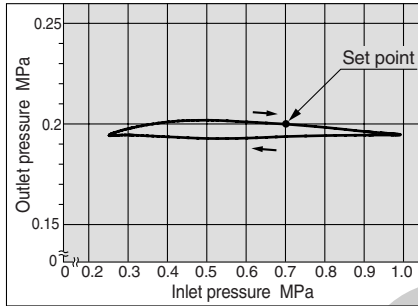

AC55

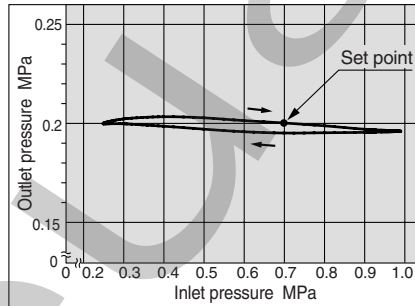

AC30

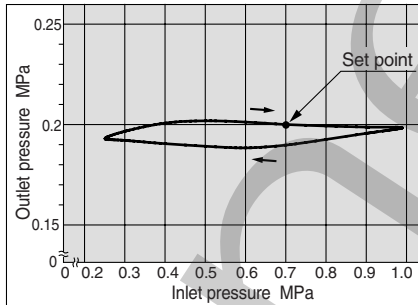

AC60

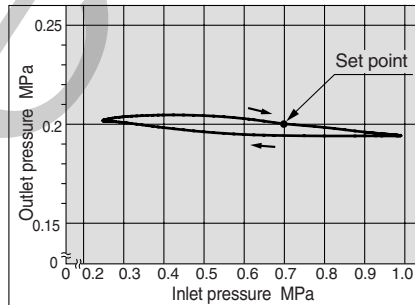

AC40

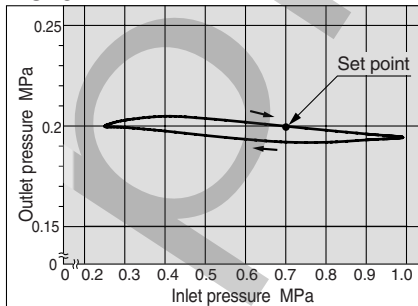

Dimensions

AC10, 20

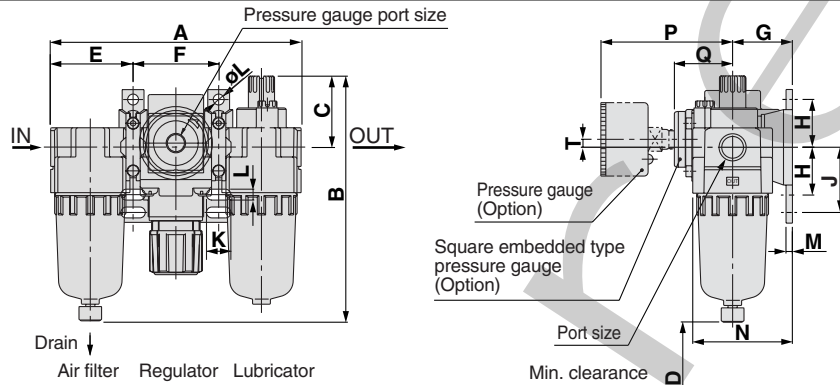

AC25, 30, 40, 50, 55, 60

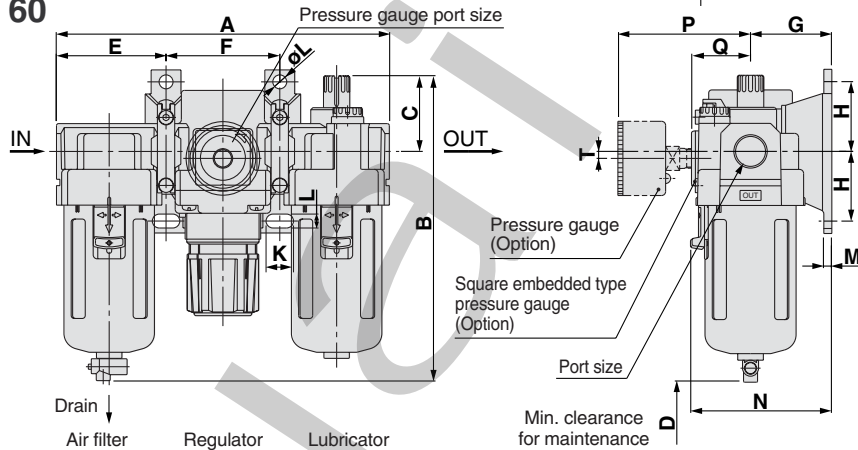

Applicable model	AC10, AC20			AC25, AC30, AC40, AC40-06, AC50, AC55, AC60			
Optional specifications	With auto drain (N.C.)	Metal bowl	With auto drain (N.O./N.C.)	Metal bowl	Metal bowl with level gauge	With drain guide	Drain cock with barb fitting
			 N.O.: Black N.C.: Gray ø10 One-touch fitting			 Width across flats 17	 Barb fitting Applicable tubing: T0604

Model	Port size	Standard specification													Accessory specification				
		A	B	C	D	Bracket mounting size								With pressure gauge		With auto drain			
						E	F	G	H	J	K	L	øL	M	N		P	Q	T
AC10	M5 x 0.8	87	85	26	35	28	31	25	20	27	7	4.5	4.5	2.8	40	26	—	0	104
AC20	1/8, 1/4	126	123	36	60	41.5	43	30	24	33	12	5.5	5.5	3.2	50	65	29.5	2 (Note 1)	141
AC25	1/4, 3/8	167	153	38	80	55	57	41	35	—	14	7	7	4	71	64	28.5	0	194
AC30	1/4, 3/8	167	153	38	80	55	57	41	35	—	14	7	7	4	71	66	30.5	3.5	194
AC40	1/4, 3/8, 1/2	220	187	40	110	72.5	75	50	40	—	18	9	9	4	88	74	35	3.5	226
AC40-06	3/4	235	187	38	110	77.5	80	50	40	—	18	9	9	4.6	88	74	35	3	226
AC50	3/4, 1	282	264	43	110	93	96	70	50	—	20	11	11	6.4	115	84	44.5	3.3	303
AC55	1	292	279	45	110	98	96	70	50	—	20	11	11	6.4	117.5	84	44.5	3.3	318
AC60	1	297	280	46	110	98	101	70	50	—	20	11	11	6.4	117.5	84	44.5	3.3	318

Model	Optional specification ^{Note 2)}			
	With barb fitting	With drain guide	Metal bowl	Metal bowl with level gauge
	B	B	B	B
AC10	—	—	85	—
AC20	—	—	123	—
AC25	161	160	166	186
AC30	161	160	166	186
AC40	195	194	200	220
AC40-06	195	194	200	220
AC50	272	271	276	296
AC55	287	286	292	312
AC60	288	287	293	313



Note 1) For AC20 only, the position of the pressure gauge is above the center of the piping.
 Note 2) For optional specifications (with barb fitting, with drain guide, with metal bowl, or with level gauge), the total length (dimension for B) will vary.

F.R.L. Unit **Filter Regulator + Lubricator**

AC10A to 40A



AC20A

AC40A

Standard Specifications

Model		AC10A	AC20A	AC30A	AC40A	AC40A-06
Component	Filter regulator	AW10	AW20	AW30	AW40	AW40-06
	Lubricator	AL10	AL20	AL30	AL40	AL40-06
Port sizes		M5 x 0.8	1/8 1/4	1/4 3/8	1/4 3/8 1/2	3/4
Pressure gauge port size ^{Note 1)}		1/16	1/8	1/8	1/4	1/4
Fluid		Air				
Proof pressure		1.5MPa				
Maximum operating pressure		1.0MPa				
Set pressure range		0.05 to 0.7MPa	0.05 to 0.85MPa			
Relief pressure		Set pressure + 0.05MPa ^{Note 2)} [at relief flow rate of 0.1L/min (ANR)]				
Ambient and fluid temperature		-5 to 60°C (with no freezing)				
Nominal filtration rating		5µm				
Recommended lubricant		Class 1 turbine oil (ISO VG32)				
Bowl material		Polycarbonate				
Bowl guard		—	Option			
Filter regulator construction		Relieving type				
Weight (kg)		0.20	0.59	0.75	1.41	1.46



Note 1) Pressure gauge connection threads are not required for F.R.L. unit with a square embedded type pressure gauge (AC20A to AC40A).
Note 2) Not applicable to AC10A.

Attachment/Accessory Part No.

Description	Model	Part no.					
		AC10A	AC20A	AC30A	AC40A	AC40A-06	
Accessories	Pressure gauge ^{Note 1)}	1.0MPa Round ^{Note 2)}	G27-10-R1	G36-10-□01	G36-10-□01	G46-10-□02	G46-10-□02
		1.0MPa Square embedded type ^{Note 2)}	—	GC3-10AS	GC3-10AS	GC3-10AS	GC3-10AS
	0.2MPa	Round ^{Note 3)}	G27-10-R1	G36-2-□01	G36-2-□01	G46-2-□02	G46-2-□02
		Square embedded type ^{Note 2)}	—	GC3-2AS	GC3-2AS	GC3-2AS	GC3-2AS
Float type auto drain ^{Note 4)}	N.O.	—	—	AD38 AD38N ^{Note 7)}	AD48 AD48N ^{Note 7)}	AD48 AD48N ^{Note 7)}	
	N.C.	AD17	AD27	AD37 AD37N ^{Note 7)}	AD47 AD47N ^{Note 7)}	AD47 AD47N ^{Note 7)}	
Spacer		Y100	Y200	Y300	Y400	Y500	
Check valve ^{Note 5)} ^{Note 6)}		—	AKM2000-□01 □02	AKM3000-□01 □02	AKM4000-□02 □03	—	
Pressure switch ^{Note 6)}		—	IS1000M-20	IS1000M-30	IS1000M-40	IS1000M-50	
T-interface ^{Note 5)} ^{Note 6)}		Y110-M5	Y210-□01 □02	Y310-□01 □02	Y410-□02 □03	Y510-□02 □03	
3-port valve for residual pressure release ^{Note 6)}		—	VHS20-□01 □02	VHS30-□02 □03	VHS40-□02 □03 □04	VHS40-□06	
Piping adapter ^{Note 6)}		E100-M5	E200-□01 □02 □03	E300-□02 □03 □04	E400-□02 □03 □04 □06	E500-□06	
Pressure switch with piping adapter ^{Note 6)}		—	IS1000E-20 □01 □02 □03	IS1000E-30 □02 □03 □04	IS1000E-40 □02 □03 □04 □06	—	
Cross interface ^{Note 6)}		Y14-M5	Y24-□01 □02	Y34-□01 □02	Y44-□02 □03	Y54-□03 □04	



Note 1) □ in part numbers for a round pressure gauge indicates a type of connection thread. No indication is necessary for R; however, indicate N for NPT.
Contact P/A regarding the connection thread NPT and pressure gauge supply for PSI unit specifications.

Note 2) Includes one O-ring and 2 mounting screws.

Note 3) For 1.0MPa.

Note 4) Minimum operating pressure: N.O. type-0.1MPa (AD17/27); N.C. type-0.15MPa (AD37/47).

Note 5) For F.R.L. units, port sizes not in () are for standard application.

Note 6) Separate interfaces are required for modular unit.

Note 7) When "N" is specified in the end of part number of auto drain, applicable tube O.D should be ø3/8".

Dimensions

AC10A, 20A

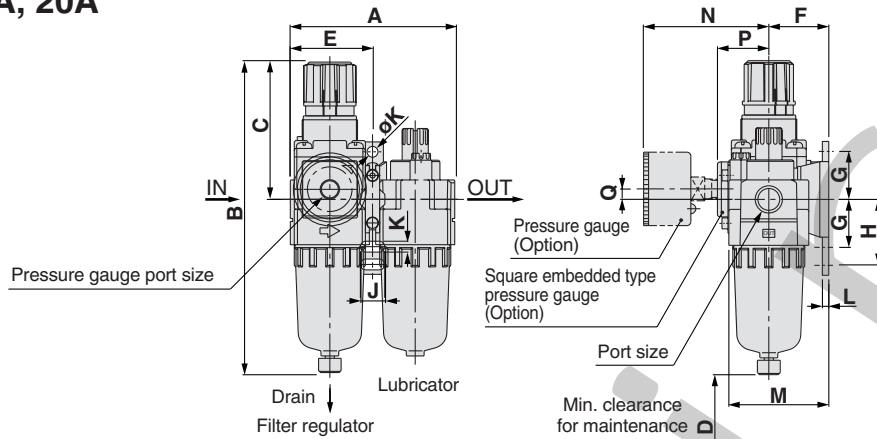

AC30A, 40A

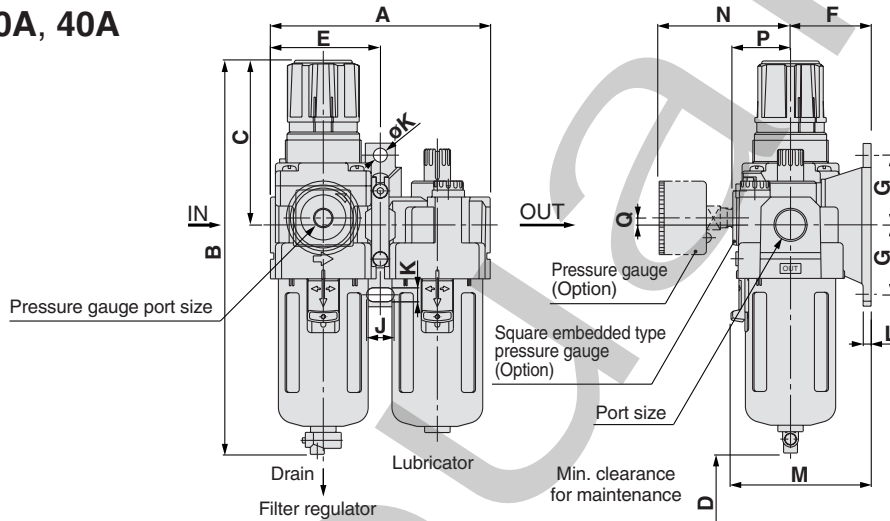

Applicable model	AC10A, AC20A			AC30A, AC40A, AC40A-06			
Optional specifications	With auto drain (N.C.)	Metal bowl	With auto drain (N.O./N.C.)	Metal bowl	Metal bowl with level gauge	With drain guide	Drain cock with barb fitting
			 N.O.: Black N.C.: Gray ø10 One-touch fitting			 1/4 Width across flats 17	 Barb fitting Applicable tubing: T0604

Model	Port size	Standard specification											Accessory specification					
		A	B	C	D	Bracket mounting size							With pressure gauge	With auto drain				
						E	F	G	H	J	K	øK			L	M	N	P
AC10A	M5 x 0.8	56	108	48	35	28	25	20	27	7	4.5	4.5	2.8	40	26	-	0	126
AC20A	1/8, 1/4	83	160	73	60	41.5	30	24	33	12	5.5	5.5	3.2	50	63	27	5	177
AC30A	1/4, 3/8	110	201	86	80	55	41	35	-	14	7	7	4	71	66	30.5	3.5	242
AC40A	1/4, 3/8, 1/2	145	239	92	110	72.5	50	40	-	18	9	9	4	88	76	38.5	1.5	278
AC40A-06	3/4	155	242	93	110	77.5	50	40	-	18	9	9	4.6	88	76	38.5	1.2	278

Model	Optional specification ^{Note 1)}			
	With barb fitting	With drain guide	Metal bowl	Metal bowl with level gauge
AC10A	B	B	B	B
AC10A	-	-	107	-
AC20A	-	-	160	-
AC30A	209	208	214	234
AC40A	247	246	251	272
AC40A-06	250	249	255	275

Note 1) For optional specifications (with barb fitting, with drain guide, with metal bowl, or with level gauge), the total length (dimension for B) will vary.

F.R.L. Unit **Air Filter + Regulator**

AC10B to 60B

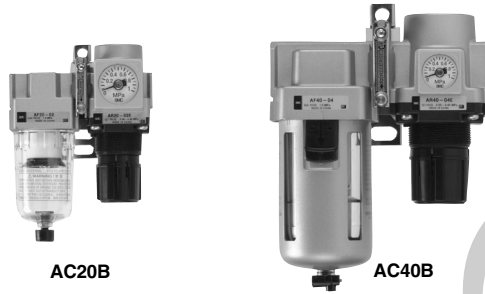

Standard Specifications

Model	AC10B	AC20B	AC25B	AC30B	AC40B	AC40B-06	AC50B	AC55B	AC60B	
Component	Air filter	AF10	AF20	AF30	AF30	AF40	AF40-06	AF50	AF60	AF60
	Regulator	AR10	AR20	AR25	AR30	AR40	AR40-06	AR50	AR50	AR60
Port sizes	M5 x 0.8	1/8 1/4	1/4 3/8	1/4 3/8	1/4 3/8 1/2	3/4	3/4 1	1	1	1
Pressure gauge port size ^{Note 1)}	1/16	1/8	1/8	1/8	1/4	1/4	1/4	1/4	1/4	1/4
Fluid	Air									
Proof pressure	1.5MPa									
Max. operating pressure	1.0MPa									
Set pressure range	0.05 to 0.7MPa	0.05 to 0.85MPa								
Relief pressure	Set pressure + 0.05MPa ^{Note 2)} [at relief flow rate of 0.1L/min (ANR)]									
Ambient and fluid temperature	-5 to 60°C (with no freezing)									
Nominal filtration rating	5µm									
Bowl material	Polycarbonate									
Bowl guard	—	Option	Standard							
Regulator construction	Relieving type									
Weight (kg)	0.16	0.51	0.55	0.63	1.12	1.16	2.44	2.45	2.54	

Note 1) Pressure gauge connection threads are not required for F.R.L. unit with a square embedded type pressure gauge (AC20B to AC60B).
Note 2) Not applicable to AC10B.

Attachment/Accessory Part No.

Description	Model	Part no.												
		AC10B	AC20B	AC25B	AC30B	AC40B	AC40B-06	AC50B	AC55B	AC60B				
Accessories	Pressure gauge ^{Note 1)}	1.0MPa	Round	G27-10-R1	G36-10-□01	G36-10-□01	G36-10-□01	G46-10-□02	G46-10-□02	G46-10-□02	G46-10-□02	G46-10-□02	G46-10-□02	
			Square ^{Note 2)} embedded type	—	GC3-10AS	GC3-10AS	GC3-10AS	GC3-10AS	GC3-10AS	GC3-10AS	GC3-10AS	GC3-10AS	GC3-10AS	GC3-10AS
	Pressure gauge ^{Note 1)}	0.2MPa	Round	G27-10-R1 ^{Note 3)}	G36-2-□01	G36-2-□01	G36-2-□01	G46-2-□02	G46-2-□02	G46-2-□02	G46-2-□02	G46-2-□02	G46-2-□02	G46-2-□02
			Square ^{Note 2)} embedded type	—	GC3-2AS	GC3-2AS	GC3-2AS	GC3-2AS	GC3-2AS	GC3-2AS	GC3-2AS	GC3-2AS	GC3-2AS	GC3-2AS
Float type auto drain ^{Note 4)}	N.O.	—	—	AD38	AD38N ^{Note 7)}	AD38	AD38N ^{Note 7)}	AD48	AD48N ^{Note 7)}	AD48	AD48N ^{Note 7)}	AD48	AD48N ^{Note 7)}	
	N.C.	AD17	AD27	AD37	AD37N ^{Note 7)}	AD37	AD37N ^{Note 7)}	AD47	AD47N ^{Note 7)}	AD47	AD47N ^{Note 7)}	AD47	AD47N ^{Note 7)}	
Spacer		Y100	Y200	Y300	Y300	Y400	Y500	Y600	Y600	Y600	Y600	Y600		
Pressure switch ^{Note 6)}		—	IS1000M-20	IS1000M-30	IS1000M-30	IS1000M-40	IS1000M-50	IS1000M-60	IS1000M-60	IS1000M-60	IS1000M-60	IS1000M-60		
T-interface ^{Note 5)} ^{Note 6)}		Y110-M5	Y210-□01 □02	Y310-□01 □02	Y310-□01 □02	Y410-□02 □03	Y510-□02 □03	Y610-□03 □04	Y610-□03 □04	Y610-□03 □04	Y610-□03 □04	Y610-□03 □04		
3-port valve for residual pressure release ^{Note 6)}		—	VHS20-□01 □02	VHS30-□02 □03	VHS30-□02 □03	VHS40-□02 □03 □04	VHS40-□06	VHS50-□06 □10	—	—	—	—		
Piping adapter ^{Note 6)}		E100-M5	E200-□01 □02 □03	E300-□02 □03 □04	E300-□02 □03 □04	E400-□02 □03 □04 □06	E500-□06	E600-□06 □10	E600-□06 □10	E600-□06 □10	E600-□06 □10			
Pressure switch with piping adapter ^{Note 6)}		—	IS1000E-20 □02 □03	IS1000E-30 □02 □03 □04	IS1000E-30 □02 □03 □04	IS1000E-40 □02 □03 □04 □06	—	—	—	—	—			
Cross interface ^{Note 6)}		Y14-M5	Y24-□01 □02	Y34-□01 □02	Y34-□01 □02	Y44-□02 □03	Y54-□03 □04	—	—	—	—			

Note 1) □ in part numbers for a round pressure gauge indicates a type of connection thread. No indication is necessary for R; however, indicate N for NPT. Contact P/A regarding the connection thread NPT and pressure gauge supply for PSI unit specifications.

Note 2) Includes one O-ring and 2 mounting screws.

Note 3) For 1.0MPa.

Note 4) Minimum operating pressure: N.O. type-0.1MPa; N.C. type-0.1MPa (AD17/27), 0.15MPa (AD37/47).

Note 5) For F.R.L. units, port sizes not in () are for standard application.

Note 6) Separate interfaces are required for modular unit.

Note 7) When "N" is specified in the end of part number of auto drain, applicable tube O.D should be ø3/8".

Dimensions

AC10B, 20B

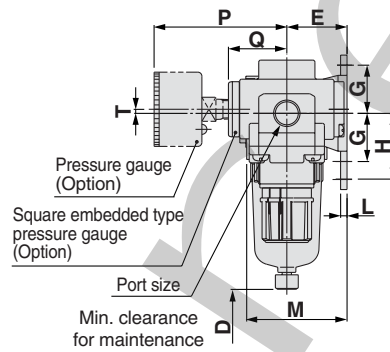
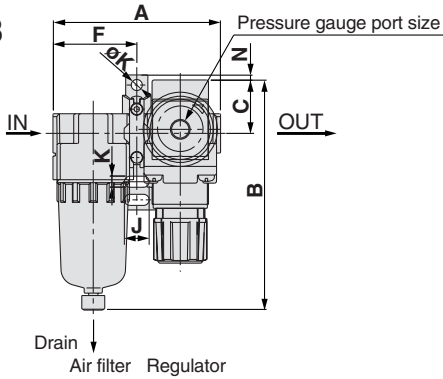

AC25B, 30B, 40B, 50B, 55B, 60B

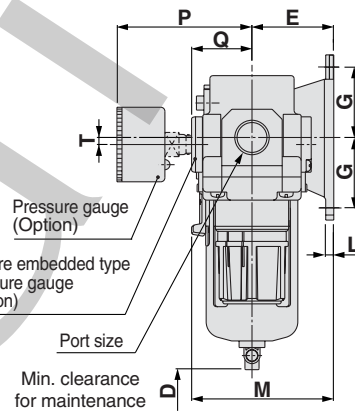
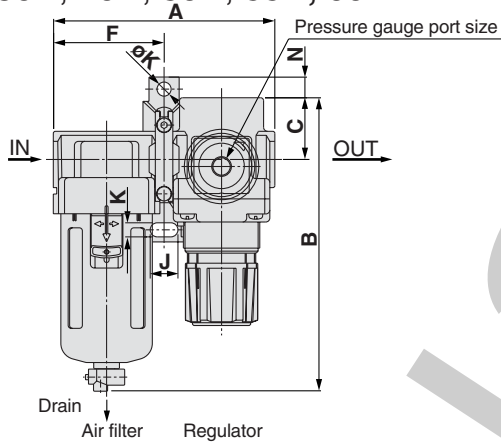

Applicable model	AC10B, AC20B		AC25B, AC30B, AC40B, AC40B-06, AC50B, AC55B, AC60B				
Optional specifications	With auto drain (N.C.)	Metal bowl	With auto drain (N.O./N.C.)	Metal bowl	Metal bowl with level gauge	With drain guide	Drain cock with barb fitting
			 N.O.: Black N.C.: Gray ø10 One-touch fitting			 Width across flats 17	 Barb fitting Applicable tubing: T0604

Model	Port size	Standard specification													Accessory specification				
		A	B	C	D	E	F	G	H	J	K	ØK	L	M	N	P	Q	T	B
AC10B	M5 x 0.8	56	71	11	25	25	28	20	27	7	4.5	4.5	2.8	40	13.5	26	—	0	89
AC20B	1/8, 1/4	83	114	26.5	40	30	41.5	24	33	12	5.5	5.5	3.2	50	2.5	65	29.5	2 Note 1)	132
AC25B	1/4, 3/8	110	143	28	50	41	55	35	—	14	7	7	4	71	13	64	28.5	0	184
AC30B	1/4, 3/8	110	146	31	50	41	55	35	—	14	7	7	4	71	10	66	30.5	3.5	187
AC40B	1/4, 3/8, 1/2	145	183	36	75	50	72.5	40	—	18	9	9	4	88	12	74	35	3.5	222
AC40B-06	3/4	155	185	36	75	50	77.5	40	—	18	9	9	4.6	88	12	74	35	3	224
AC50B	3/4, 1	186	264	43	20	70	93	50	—	20	11	11	6.4	115	16	84	44.5	3.3	303
AC55B	1	191	277	43	20	70	98	50	—	20	11	11	6.4	117.5	16	84	44.5	3.3	316
AC60B	1	196	280	46	20	70	98	50	—	20	11	11	6.4	117.5	13	84	44.5	3.3	319

Model	Optional specification ^{Note 2)}			
	With barb fitting	With drain guide	Metal bowl	Metal bowl with level gauge
	B	B	B	B
AC10B	—	—	70	—
AC20B	—	—	114	—
AC25B	151	150	156	176
AC30B	154	153	159	179
AC40B	191	190	196	216
AC40B-06	193	192	198	218
AC50B	272	271	277	297
AC55B	285	284	290	310
AC60B	288	287	293	313



Note 1) For AC20 only, the position of the pressure gauge is above the center of the piping.

Note 2) For optional specifications (with barb fitting, with drain guide, with metal bowl, or with level gauge), the total length (dimension for B) will vary.

F.R.L. Unit Air Filter + Mist Separator + Regulator

AC20C to 40C



AC20C



AC40C

JIS symbol

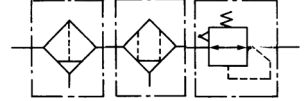

Air filter Mist separator Regulator

Standard Specifications

Model		AC20C	AC25C	AC30C	AC40C	AC40C-06
Component	Air filter	AF20	AF30	AF30	AF40	AF40-06
	Mist separator	AFM20	AFM30	AFM30	AFM40	AFM40-06
	Regulator	AR20	AR25	AR30	AR40	AR40-06
Port sizes		1/8 1/4	1/4 3/8	1/4 3/8	1/4 3/8 1/2	3/4
Pressure gauge port size ^{Note 1)}		1/8	1/8	1/8	1/4	1/4
Fluid		Air				
Proof pressure		1.5MPa				
Maximum operating pressure		1.0MPa				
Minimum operating pressure		0.05MPa				
Set pressure range		0.05 to 0.85MPa				
Rated flow L/min (ANR) ^{Note 2)}		200	450	450	1100	1100
Relief pressure		Set pressure + 0.05MPa [at relief flow rate of 0.1L/min (ANR)]				
Ambient and fluid temperature		-5 to 60°C (with no freezing)				
Nominal filtration rating		AF: 5µm; AFM: 0.3µm (95% filtered particle size)				
Outlet side oil mist concentration		Maximum 1.0mg/m ³ (ANR) (approx. 0.8ppm) ^{Note 3)}				
Bowl material		Polycarbonate				
Bowl guard		Option	Standard			
Filter regulator construction		Relieving type				
Weight (kg)		0.74	0.88	0.95	1.76	1.83



Note 1) Pressure gauge connection threads are not required for F.R.L. unit with a square embedded type pressure gauge (AC20C to AC40C).

Note 2) Conditions: Inlet pressure: 0.7MPa; Set pressure: 0.5MPa. The rated flow varies depending on the inlet pressure.

Note 3) At compressor discharge 30mg/Nm³.

Attachment/Accessory Part No.

Description	Model	Part no.						
		AC20C	AC25C	AC30C	AC40C	AC40C-06		
Accessories	Pressure gauge ^{Note 1)}	1.0MPa	Round	G36-10-□01	G36-10-□01	G36-10-□01	G46-10-□02	G46-10-□02
			Square embedded type ^{Note 2)}	GC3-10AS	GC3-10AS	GC3-10AS	GC3-10AS	GC3-10AS
		0.2MPa	Round	G36-2-□01	G36-2-□01	G36-2-□01	G46-2-□02	G46-2-□02
			Square embedded type ^{Note 2)}	GC3-2AS	GC3-2AS	GC3-2AS	GC3-2AS	GC3-2AS
Float type auto drain ^{Note 3)}	N.O.	—	AD38	AD38N ^{Note 6)}	AD38	AD38N ^{Note 6)}	AD48	AD48N ^{Note 6)}
	N.C.	AD27	AD37	AD37N ^{Note 6)}	AD37	AD37N ^{Note 6)}	AD47	AD47N ^{Note 6)}
Spacer		Y200	Y300	Y300	Y400	Y500		
Pressure switch ^{Note 5)}		IS1000M-20	IS1000M-30	IS1000M-30	IS1000M-40	IS1000M-50		
T-interface ^{Note 4)} ^{Note 5)}		Y210- □01 □02	Y310- (□01) □02	Y310- (□01) □02	Y410- (□02) □03	Y510- (□02) □03		
3-port valve for residual pressure release ^{Note 5)}		VHS20- □01 □02	VHS30- □02 □03	VHS30- □02 □03	VHS40- □02 □03 □04	VHS40- □06		
Piping adapter ^{Note 5)}		E200- □01 □02 □03	E300- □02 □03 □04	E300- □02 □03 □04	E400- □02 □03 □04 □06	E500- □06		
Pressure switch with piping adapter ^{Note 5)}		IS1000E-20 □01 □02 □03	IS1000E-30 □02 □03 □04	IS1000E-30 □02 □03 □04	IS1000E-40 □02 □03 □04 □06	—		
Cross interface ^{Note 5)}		Y24- □01 □02	Y34- □01 □02	Y34- □01 □02	Y44- □02 □03	Y54- □03 □04		



Note 1) □ in part number for the round pressure gauge indicates a type of connection thread. No indication is necessary for R; however, indicate N for NPT.

Contact P/A regarding the connection thread NPT and pressure gauge supply for PSI unit specifications.

Note 2) Includes one O-ring and 2 mounting screws.

Note 3) Minimum operating pressure: N.O. type-0.1MPa; N.C. type-0.1 MPa (AD27), 0.15MPa (AD37/47).

Note 4) For F.R.L. units, port sizes not in () are for standard application.

Note 5) Separate interfaces are required for modular unit.

Note 6) When "N" is specified in the end of part number of auto drain, applicable tube O.D should be ø3/8".

Dimensions

AC20C

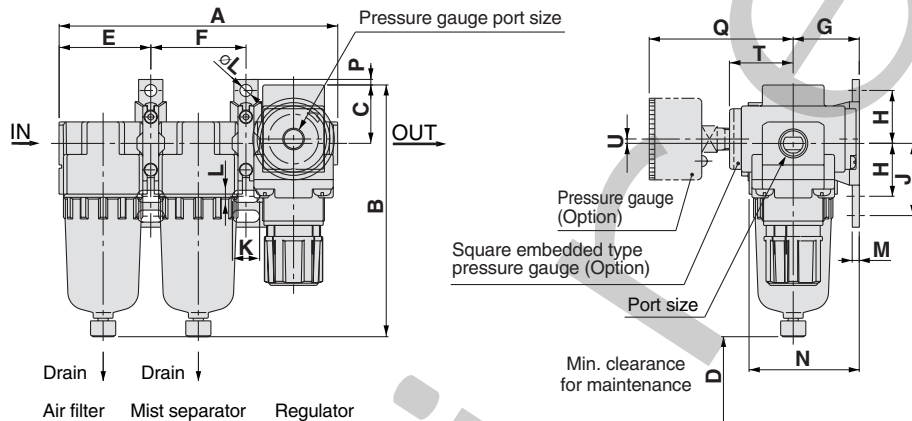

AC25C, 30C, 40C

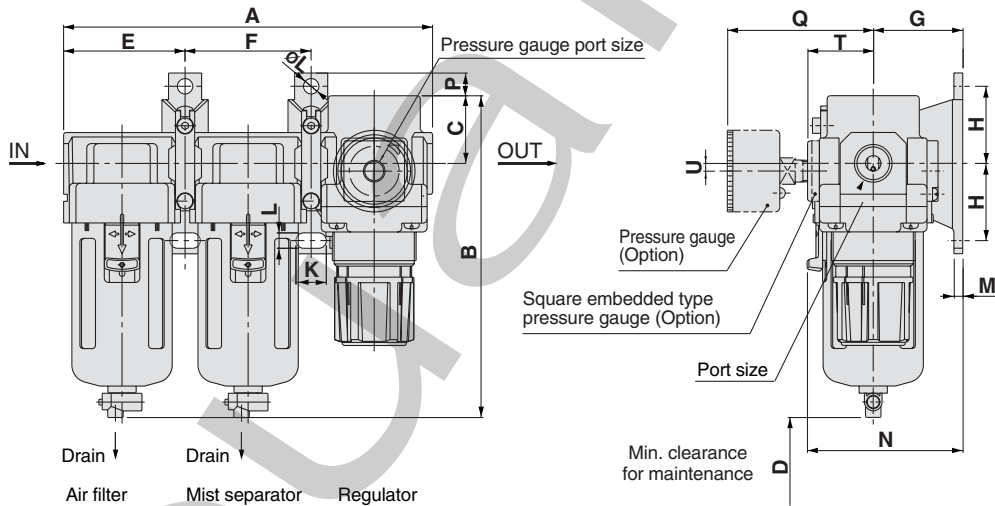

Applicable model	AC20C			AC25C, AC30C, AC40C, AC40C-06										
Optional specifications	With auto drain (N.C.)	Metal bowl	With auto drain (N.O./N.C.)	Metal bowl	Metal bowl with level gauge	With drain guide	Drain cock with barb fitting							
												Barb fitting Applicable tubing: T0604		

Model	Port size	Standard specification														Accessory specification				
		A	B	C	D	Bracket mounting size										With pressure gauge		With auto drain		
						E	F	G	H	J	K	L	øL	M	N	P	Q	T	U	B
AC20C	1/8, 1/4	126	114	26.5	45	41.5	43	30	24	33	12	5.5	5.5	3.2	50	2.5	65	29.5	2 (Note 1)	132
AC25C	1/4, 3/8	167	143	28	50	55	57	41	35	—	14	7	7	4	71	13	64	28.5	0	184
AC30C	1/4, 3/8	167	146	31	50	55	57	41	35	—	14	7	7	4	71	10	66	30.5	3.5	187
AC40C	1/4, 3/8, 1/2	220	183	36	75	72.5	75	50	40	—	18	9	9	4	88	12	74	35	3.5	222
AC40C-06	3/4	235	185	36	75	77.5	80	50	40	—	18	9	9	4.6	88	12	74	35	3	224

Model	Optional specification ^{Note 2)}			
	With barb fitting	With drain guide	Metal bowl	Metal bowl with level gauge
AC20C	—	—	114	—
AC25C	151	150	156	176
AC30C	154	153	159	179
AC40C	191	190	196	216
AC40C-06	193	192	198	218

Note 1) For AC20 only, the position of the pressure gauge is above the center of the piping.

Note 2) For optional specifications (with barb fitting, with drain guide, with metal bowl, or with level gauge), the total length (dimension for B) will vary.

F.R.L. Unit **Filter Regulator + Mist Separator**

AC20D to 40D

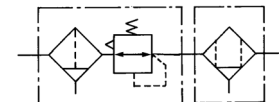
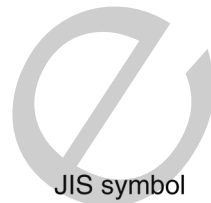

Filter regulator Mist separator

Standard Specifications

Model		AC20D	AC30D	AC40D	AC40D-06
Component	Filter regulator	AW20	AW30	AW40	AW40-06
	Mist separator	AFM20	AFM30	AFM40	AFM40-06
Port sizes		1/8 1/4	1/4 3/8	1/4 3/8 1/2	3/4
Pressure gauge port size ^{Note 1)}		1/8	1/8	1/4	1/4
Fluid		Air			
Proof pressure		1.5MPa			
Maximum operating pressure		1.0MPa			
Minimum operating pressure		0.05MPa			
Set pressure range		0.05 to 0.85MPa			
Rated flow L/min (ANR) ^{Note 2)}		150	330	800	800
Relief pressure		Set pressure + 0.05MPa [at relief flow rate of 0.1L/min (ANR)]			
Ambient and fluid temperature		-5 to 60°C (with no freezing)			
Nominal filtration rating		AW: 5µm; AFM: 0.3µm (95% filtered particle size)			
Outlet side oil mist concentration		Maximum 1.0mg/m ³ (ANR) (approx. 0.8ppm) ^{Note 3)}			
Bowl material		Polycarbonate			
Bowl guard		Option	Standard		
Filter regulator construction		Relieving type			
Weight (kg)		0.57	0.74	1.38	1.43



Note 1) Pressure gauge connection threads are not required for F.R.L. unit with a square embedded type pressure gauge (AC20D to AC40D).

Note 2) Conditions: Inlet pressure: 0.7MPa; Set pressure: 0.5MPa. The rated flow varies depending on the inlet pressure.

Note 3) At compressor discharge of 30mg/Nm³.

Attachment/Accessory Part No.

Description	Model	Part no.							
		AC20D		AC30D		AC40D		AC40D-06	
Accessories	Pressure gauge ^{Note 1)}	1.0MPa	Round	G36-10-□01	G36-10-□01	G46-10-□02	G46-10-□02		
			Square embedded type ^{Note 2)}	GC3-10AS	GC3-10AS	GC3-10AS	GC3-10AS		
		0.2MPa	Round	G36-2-□01	G36-2-□01	G46-2-□02	G46-2-□02		
			Square embedded type ^{Note 2)}	GC3-2AS	GC3-2AS	GC3-2AS	GC3-2AS		
Float type auto drain ^{Note 3)}	N.O.	—	AD38	AD38N ^{Note 6)}	AD48	AD48N ^{Note 6)}	AD48	AD48N ^{Note 6)}	
	N.C.	AD27	AD37	AD37N ^{Note 6)}	AD47	AD47N ^{Note 6)}	AD47	AD47N ^{Note 6)}	
Spacer		Y200	Y300		Y400		Y500		
Pressure switch ^{Note 5)}		IS1000M-20	IS1000M-30		IS1000M-40		IS1000M-50		
T-Interface ^{Note 4)} ^{Note 5)}		Y210- ^{□01} _(□02)	Y310- ^{□01} _(□02)		Y410- ^{□02} _(□03)		Y510- ^{□02} _(□03)		
3-port valve for residual pressure release ^{Note 5)}		VHS20- ^{□01} _(□02)	VHS30- ^{□02} _(□03)		VHS40- ^{□02} _(□03) _(□04)		VHS40-□06		
Piping adapter ^{Note 5)}		E200- ^{□01} _(□02) _(□03)	E300- ^{□02} _(□03) _(□04)		E400- ^{□02} _(□03) _(□04) _(□06)		E500-□06		
Pressure switch with piping adapter ^{Note 5)}		IS1000E-20- ^{□01} _(□02) _(□03)	IS1000E-30- ^{□02} _(□03) _(□04)		IS1000E-40- ^{□02} _(□03) _(□04) _(□06)		—		
Cross interface ^{Note 5)}		Y24- ^{□01} _(□02)	Y34- ^{□01} _(□02)		Y44- ^{□02} _(□03)		Y54- ^{□03} _(□04)		



Note 1) □ in part number for the round pressure gauge indicates a type of connection thread. No indication is necessary for R; however, indicate N for NPT.

Contact P/A regarding the connection thread NPT and pressure gauge supply for PSI unit specifications.

Note 2) Includes one O-ring and 2 mounting screws.

Note 3) Minimum operating pressure: N.O. type-0.1MPa; N.C. type-0.1MPa (AD27), 0.15MPa (AD37/47).

Note 4) For F.R.L. units, port sizes not in () are for standard application.

Note 5) Separate interfaces are required for modular unit.

Note 6) When "N" is specified in the end of part number of auto drain, applicable tube O.D should be ø3/8".

Dimensions

AC20D

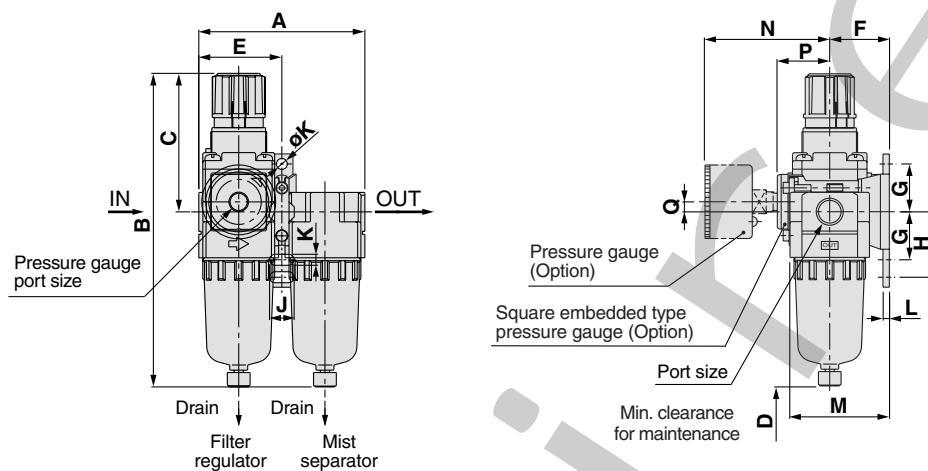

AC30D, 40D

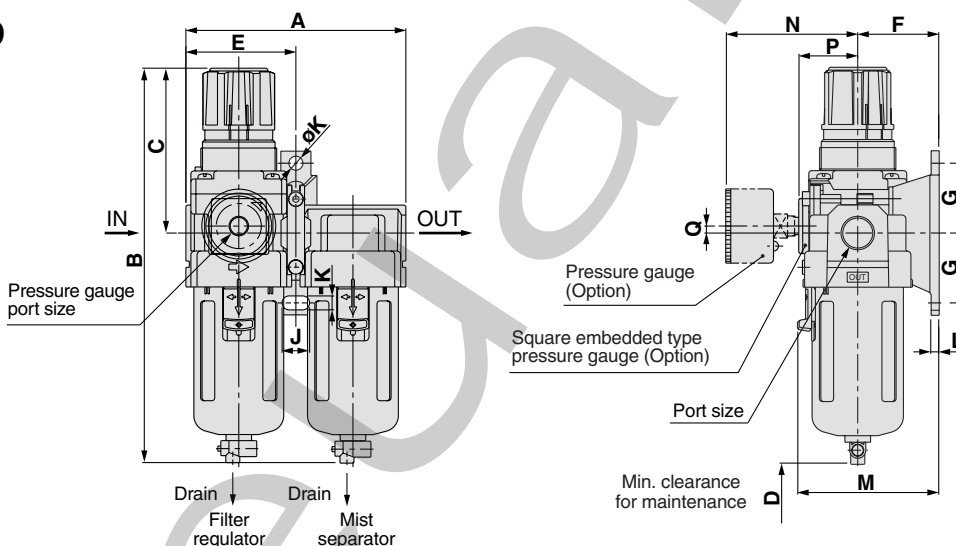

Applicable model	AC20D			AC30D, AC40D, AC40D-06			
Optional specifications	With auto drain (N.C.)	Metal bowl	With auto drain (N.O./N.C.)	Metal bowl	Metal bowl with level gauge	With drain guide	Drain cock with barb fitting

Model	Port size	Standard specification													Accessory specification			
		A	B	C	D	Bracket mounting size								With pressure gauge		With auto drain		
						E	F	G	H	J	K	øK	L	M	N	P	Q	B
AC20D	1/8, 1/4	83	160	73	45	41.5	30	24	33	12	5.5	5.5	3.2	50	63	27	5	177
AC30D	1/4, 3/8	110	201	86	55	55	41	35	—	14	7	7	4	71	66	30.5	3.5	242
AC40D	1/4, 3/8, 1/2	145	239	92	80	72.5	50	40	—	18	9	9	4	88	76	38.5	1.5	278
AC40D-06	3/4	155	242	93	80	77.5	50	40	—	18	9	9	4.6	88	76	38.5	1.2	278

Model	Optional specification ^{Note 1)}			
	With barb fitting	With drain guide	Metal bowl	Metal bowl with level gauge
	B	B	B	B
AC20D	—	—	160	—
AC30D	209	208	214	234
AC40D	247	246	251	272
AC40D-06	250	249	255	275

Note 1) For optional specifications (with barb fitting, with drain guide, with metal bowl, or with level gauge), the total length (dimension for B) will vary.

F.R.L. Unit Series AC Attachment Specifications

Piping Adapter (E)

M5 x 0.8, 1/8, 1/4, 3/8, 1/2, 3/4, 1

A piping adapter allows installation/removal of the component without removing the piping and thus makes maintenance easier.

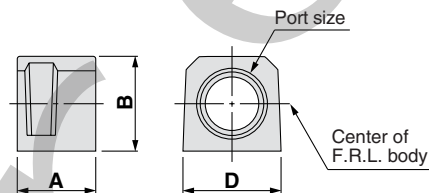
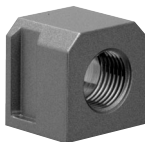

Model ^{Note)}	Port size	A	B	D	Applicable model
E100-M5	M5 x 0.8	10	14	14	AC10□, AW10, AF10, AR10, AL10
E200-□01	1/8	30	23.5	28	AC20□
E200-□02	1/4				AF20, AR20□, AW20□
E200-□03	3/8				AL20, AFM20, AFD20, AWM20, AWD20
E300-□02	1/4	32	30	30	AC25□, AC30□
E300-□03	3/8				AF30, AR30□, AW30□
E300-□04	1/2				AL30, AFM30, AFD30, AWM30, AWD30
E400-□02	1/4	32	36	36	AC40□
E400-□03	3/8				AF40, AR40□, AW40□
E400-□04	1/2				AL40, AFM40, AFD40
E400-□06	3/4				AWM40, AWD40
E500-□06	3/4	32	40	44	AC40□-06, AF40-06, AR40□-06, AW40□-06 AL40-06, AFM40-06, AFD40-06
E600-□06	3/4	35	48	53	AC50, AC55, AC60, AC50B, AC55B, AC60B
E600-□10	1				AF50, AR50□, AL50, AF60, AR60□, AL60

Notes) • □ in model numbers indicates a thread type. No indication is necessary for Rc; however, indicate N for NPT, and F for G.

• Separate interfaces are required for modular unit.

* Factory mounting of a piping adapter on the AC models is available as a special order.

T-interface (T)

M5 x 0.8, 1/8, 1/4, 3/8, 1/2

Using a T-interface facilitates the redirection of air flow.

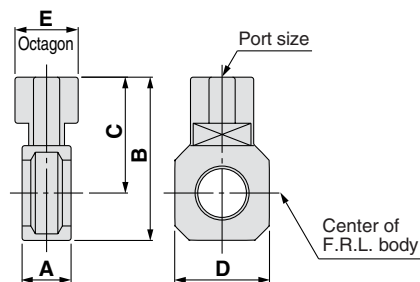
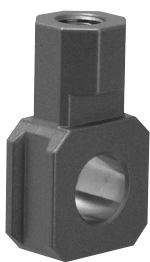

Model	Port size	A	B	C	D	E	Applicable model
Y110-M5	M5 x 0.8	11	19	12	14	8	AC10, AC10B
Y210-□01	1/8	15	42	32	28	19	AC20, AC20B
Y210-□02	1/4						AC20C
Y310-□01	1/8	15	53	39	30	19	AC25, AC25B
Y310-□02	1/4						AC25C, AC30
Y410-□02	1/4	19	62	44	36	24	AC30B, AC30C
Y410-□03	3/8						AC40, AC40B
Y510-□02	1/4	19	66	46	44	24	AC40C
Y510-□03	3/8						AC40-06, AC40B-06
Y610-□03	3/8	22	81	57	53	30	AC40C-06
Y610-□04	1/2						AC50, AC55
							AC60, AC50B
							AC55B, AC60B

Notes) • □ in model numbers indicates a thread type. No indication is necessary for Rc; however, indicate N for NPT, and F for G.

• Separate interfaces are required for modular unit.

* Refer to the attachment table on Front matter 2 for standard port sizes when using with AC.

Caution in Mounting

- If a T-interface is used on the IN side of the lubricator, lubricant may be mixed. Use the series AKM check valve to avoid such possibility.

Pressure Switch with Piping Adapter (P)

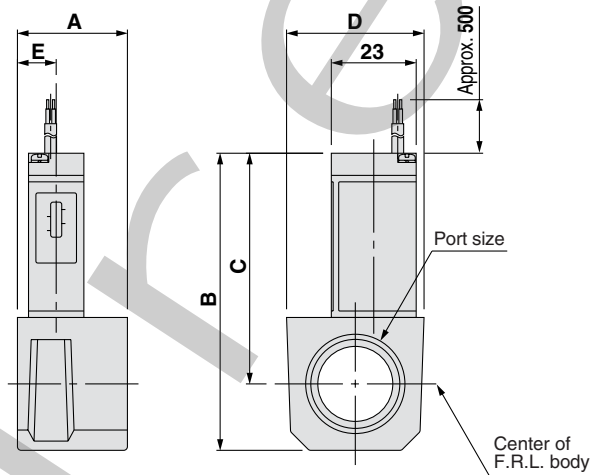
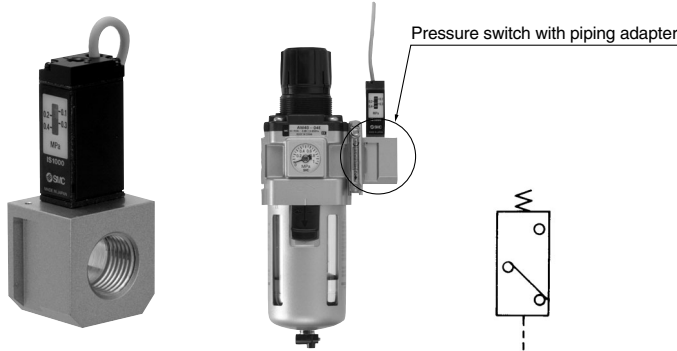

Specifications

Fluid	Air
Proof pressure	1.0MPa
Maximum operating pressure	0.7MPa
Set pressure range (when OFF)	0.1 to 0.4MPa
Differential	0.08MPa
Ambient and fluid temperature	-5 to 60°C (with no freezing)

Switch characteristics

Contact point configuration	1a
Maximum contact point capacity	2VA(AC), 2W(DC)
Operating voltage: AC, DC	100V or less
Max. operating current	12V to 24V AC, DC: 50mA
	48V AC, DC: 40mA
	100V AC, DC: 20mA

Model ^{Note 1)}	Port size	A	B	C	D	E	Applicable model
IS1000E-20□01	1/8	30	68	57	28	16	AC20□
IS1000E-20□02	1/4						AR20□, AW20□
IS1000E-20□03	3/8						AWM20, AWD20
IS1000E-30□02	1/4	32	74.5	60.5	30	13	AC25□, AC30□
IS1000E-30□03	3/8						AR25□, AR30□, AW30□
IS1000E-30□04	1/2						AWM30, AWD30
IS1000E-40□02	1/4	32	80.5	62.5	37	12.5	AC40□ ^{Note 2)}
IS1000E-40□03	3/8						AR40□, AW40□
IS1000E-40□04	1/2						AWM40, AWD40
IS1000E-40□06	3/4						

Note 1) □ in the model numbers indicates a thread type. No indication is necessary for Rc; however, indicate N for NPT, and F for G.

Note 2) A pressure switch cannot be mounted on AC40□-06 and AW40□-06.

* Separate interfaces are required for modular unit.

** The pressure switch on AC40□-06 and above and AW40□-06 can be mounted by screwing IS1000-01 into the piping adapter E500-□06-X501 or E600-□06-X501 to E600-□06 to 10-X501 (with top-face thread Rc 1/8). Products with a premounted switch are available as a special order. Please contact P/A regarding their availability.

How to Order

IS1000E-30□03□

Pressure switch with piping adapter

Body size

20	For AC20
30	For AC25, AC30
40	For AC40-02 to 04

Thread type

Nil	Rc
N	NPT
F	G

Option

X201	Lead wire length: 3m
X202	Regulating pressure range: 0.1 to 0.6MPa
X207	MPa/PSI Dual scale
X215	Lead wire length: 3m; Regulating pressure range: 0.1 to 0.6MPa
X250	Opposite-side mounting (Left-side mounting type)
X251	Lead wire length: 3m; Opposite-side mounting (Left-side mounting type)
X252	Set pressure range: 0.1 to 0.6MPa; Opposite-side mounting (Left-side mounting type)
X253	Lead wire length: 3m; Regulating pressure range: 0.1 to 0.6MPa; Opposite-side mounting (Left-side mounting type)

This product is for overseas use only according to the new Measurement Law. (The SI unit type is provided for use in Japan.)

Piping adapter port size

Symbol	Port size	Body size		
		20	30	40
01	1/8	●	—	—
02	1/4	●	●	●
03	3/8	●	●	●
04	1/2	—	●	●
06	3/4	—	—	●

Series AC

Check Valve (K) Rc1/8, 1/4, 3/8

A check valve with intermediate air release port can be easily installed to prevent a back flow of lubricant when redirecting the air flow and releasing the air on the outlet side of the regulator.

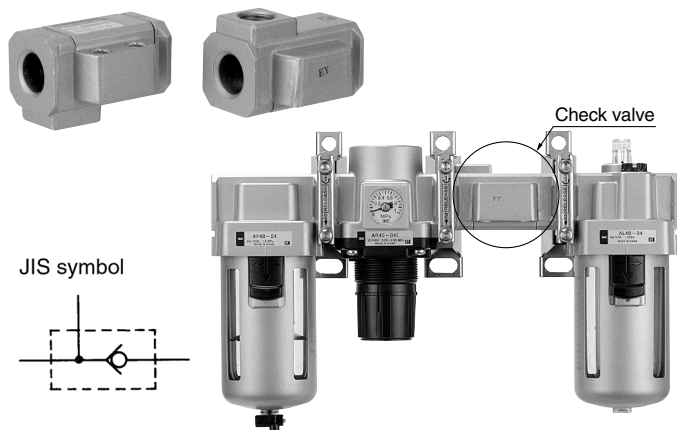

Specifications

Model	Effective area (mm ²)
AKM2000	28
AKM3000	55
AKM4000	111

Be sure to use above check valves when redirecting the air flow on the inlet side of the lubricator. Threads for IN and OUT ports are not machined.

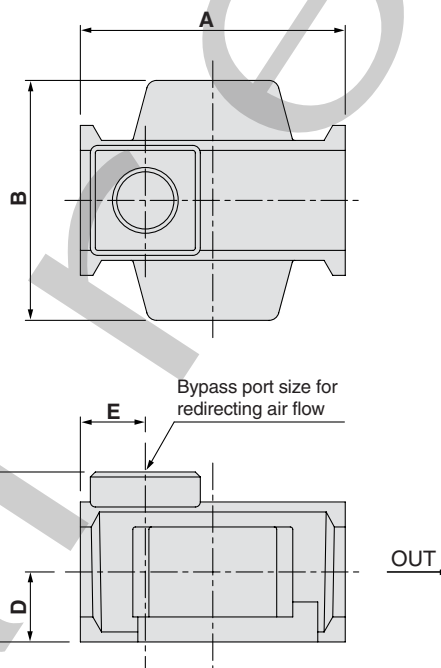

Model	Bypass port sizes	A	B	C	D	E	Applicable model
AKM2000	1/8, 1/4	40	40	28	11	11	AC20, AC20A
AKM3000	1/8, 1/4	53	48	34	14	13	AC25, AC25A AC30, AC30A
AKM4000	1/4, 3/8	70	54	42	18	15	AC40, AC40A ^{Note)}

Note) Not applicable to AC40□-06.

* Refer to the attachment table on page 1 or 5 for standard bypass port sizes applicable to AC.

How to Order

AKM 30 00 - 01

Check valve
Body size
20 30 40

Bypass port size for redirecting air flow

Symbol	Port size	Body size		
		20	30	40
01	1/8	●	●	—
02	1/4	●	●	●
03	3/8	—	—	●

Thread type

Nil	Rc
N	NPT
F	G

Pressure Switch (S)

A compact integrated pressure switch can be easily installed and facilitates the pressure detection of the line.



Specifications

Fluid	Air
Proof pressure	1.0MPa
Maximum operating pressure	0.7MPa
Set pressure range (off)	0.1 to 0.4MPa
Differential	0.08MPa
Ambient and fluid temperature	-5 to 60°C (with no freezing)

Switch characteristics

Contact point configuration	1a
Maximum contact point capacity	2VA(AC), 2W(DC)
Operating voltage: AC, DC	100V or less
Maximum operating current	AC, DC12V to 24V: 50mA AC, DC48V: 40mA AC, DC100V: 20mA

Cross Interface (C)

M5 x 0.8, 1/8, 1/4, 3/8, 1/2

Pipings are possible in all 4 directions.

IN/OUT ports are not machined for threads. Contact P/A if threaded (machined) ports are required.

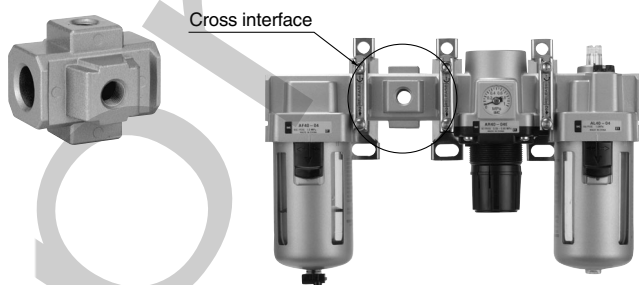

Cautions in Mounting

- When mounting a cross interface directly on the IN side of the lubricator, be sure to use a series AKM check valve between the lubricator and cross interface.
- Factory mounting of a cross interface on the AC model is available as a special order.

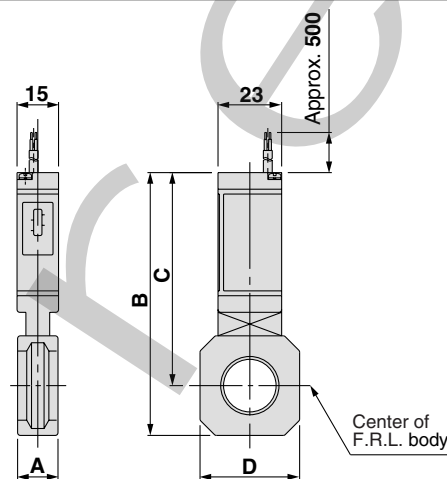

Model	A	B	C	D	Applicable model
IS1000M-20	11	76	66	28	AC20□
IS1000M-30	13	86	72	30	AC25□, AC30□
IS1000M-40	15	95	77	36	AC40□
IS1000M-50	17	99	79	44	AC40□-06
IS1000M-60	22	92.5	68.5	53	AC50□, AC55□, AC60□

Note) Separate interfaces are required for modular unit.

How to Order

IS1000M-30

Pressure switch Body size

20	For AC20
30	For AC25, AC30
40	For AC40-02 to 04
50	For AC40-06
60	For AC50, AC55, AC60

Accessories

X201	Lead wire length: 3m
X202	Regulating pressure range: 0.1 to 0.6MPa
X207	MPa/PSI Dual scale
X215	Lead wire length: 3m; Regulating pressure range: 0.1 to 0.6MPa

This product is for overseas use only according to the new Measurement Law. (The SI unit type is provided for use in Japan.)

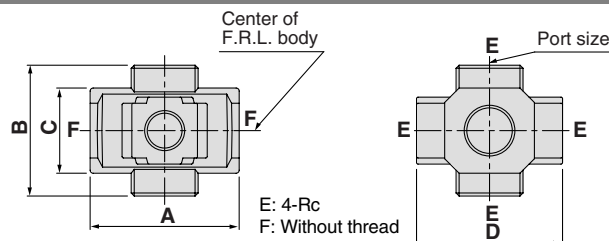

Model	Port size	A	B	C	D	Applicable model
Y14-M5	M5	23	16	14	25	AC10□
Y24-□01	1/8	40	40	22	40	AC20□
Y24-□02	1/4					
Y34-□01	1/8	49	43	28	48	AC25□, AC30□
Y34-□02	1/4					
Y44-□02	1/4	60	48	36	54	AC40□
Y44-□03	3/8					
Y54-□03	3/8	72	62	40	62	AC40□-06
Y54-□04	1/2					

Notes) □ in the model numbers indicates a thread type. No indication is necessary for Rc; however, indicate N for NPT, and F for G.

• If threaded ports are required, they are available as a special order. Contact P/A.

Series AC

3-Port Valve for Residual Pressure Release (V)

With the use of a 3-port valve for residual pressure release, pressure left in the line can be easily exhausted.

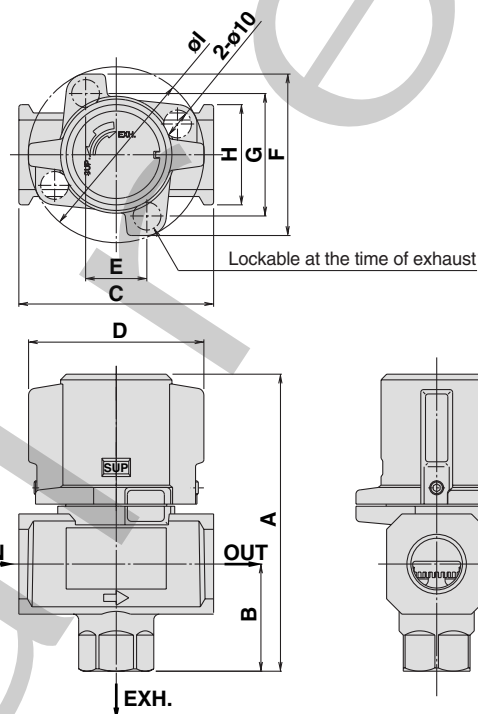
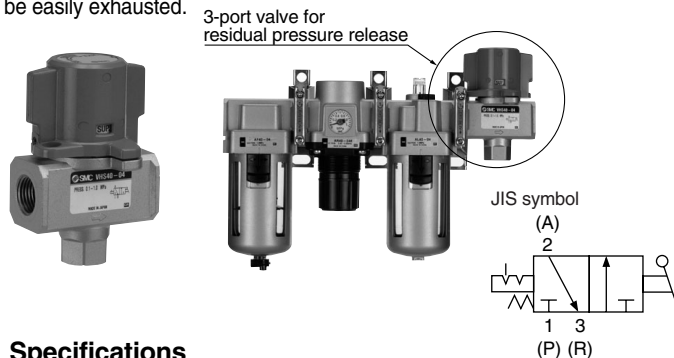

Specifications

Model	Port size		Effective area (mm ²) (Effective Area mm ² (Cv))	
	IN,OUT	EXH.	IN to OUT	OUT to EXH.
VHS20	1/8	1/8	10 (0.54)	11 (0.60)
	1/4		14 (0.76)	16 (0.87)
VHS30	1/4	1/4	16 (0.87)	14 (0.76)
	3/8		31 (1.68)	29 (1.57)
VHS40	1/4	3/8	27 (1.46)	36 (1.95)
	3/8		38 (2.06)	40 (2.17)
	1/2		55 (2.98)	42 (2.28)
VHS40-06	3/4	1/2	77 (1.73)	49 (2.66)
VHS50	3/4	1/2	82 (4.44)	50 (2.71)
	1		125 (6.78)	53 (2.87)

Note) Use an air filter on the IN side for operating protection.

Model	A	B	C	D	E	F	G	H	I
VHS20	59	20	40	34	-	45	33	28	45
VHS30	78	29	53	46	-	55	42	30	55
VHS40	107	39	70	63	22	58	44	36	63
VHS40-06	110	42	75	67	21	65	50	44	69
VHS50	134	53	90	78	26	76	61	54	81

How to Order

VHS 30-F 03-RZ

3-port valve for residual pressure release

Body size

Symbol	Applicable model
20	AC20
30	AC25,30
40	AC40
50	AC50, AC60 (Note)

Note) When the valve is mounted on AC60, the flow rate may decrease depending upon the mounting position.

Thread type

Nil	Rc
N	NPT
F	G

Port size

Symbol	Port size	Body size			
		20	30	40	50
01	1/8	√	—	—	—
02	1/4	√	√	√	—
03	3/8	—	√	√	—
04	1/2	—	—	√	—
06	3/4	—	—	√	√
10	1	—	—	—	√

Caution

1. Consult P/A when a pressure switch and T type spacer are installed on the outlet of pressure release valve
2. If a stop valve or a silencer is connected to the exhaust port of VHS20/30, the effective sectional area should be larger than the figure indicated in the following table, to prevent malfunction caused by back pressure. (This is not applicable to VHS40 and VHS50)

Model	Effective area (mm ²)
VHS20	5
VHS30	5

Optional specifications

Code	Description
R	Flow direction: Right to left
Z (Note 1)	Name plate in imperial units (PSI, °F)

Note 1) This product is for overseas use only according to the new Measurement Law. (The SI unit type is provided for use in Japan.)

Series AC Spacers and Brackets Accessories

Spacer (X)

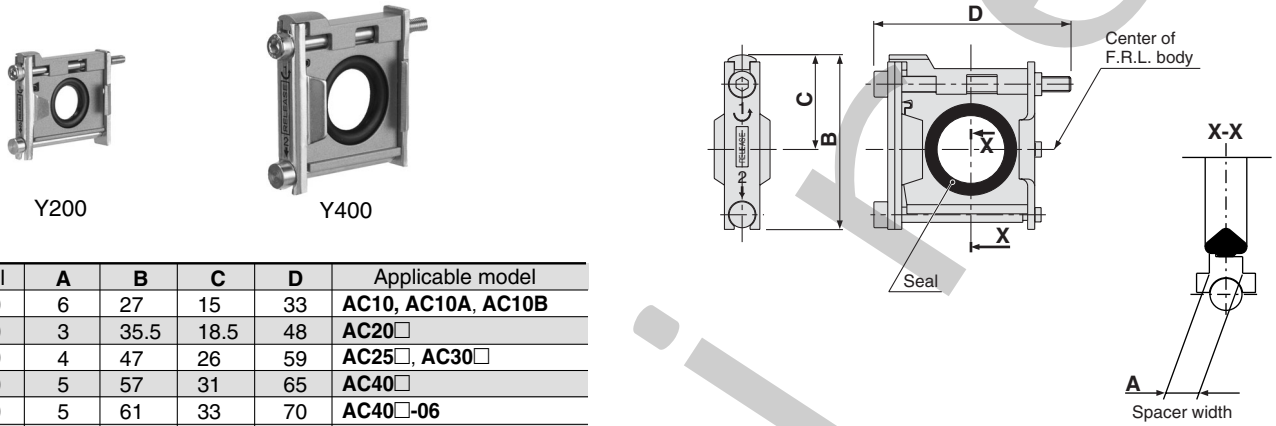

Model	A	B	C	D	Applicable model
Y100	6	27	15	33	AC10, AC10A, AC10B
Y200	3	35.5	18.5	48	AC20□
Y300	4	47	26	59	AC25□, AC30□
Y400	5	57	31	65	AC40□
Y500	5	61	33	70	AC40□-06
Y600	6	75.5	41	86	AC50, AC55, AC60 AC50B, AC55B, AC60B

Replacement parts

Description	Material	Part no.					
		Y100	Y200	Y300	Y400	Y500	Y600
Seal	HNBR ^{Note 2)}	Y100P-060AS ^{Note 1)}	Y200P-060S	Y300P-060S	Y400P-060S	Y500P-060S	Y600P-060S

Note 1) Y-100 comes with 2 O-rings.

Note 2) NBR seal is used for Y100 spacer because of no direct contact with fluid.

Spacer with Bracket (Z)

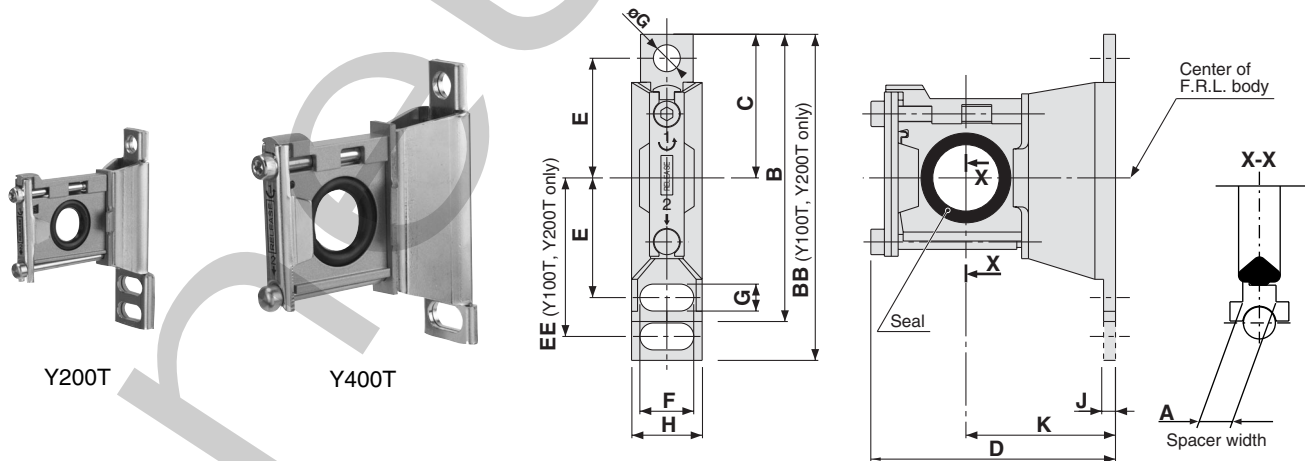

Model	A	B	BB	C	D	E	EE	F	G	øG	H	J	K	Applicable model
Y100T	6	—	56	24.5	40.5	20	27	6.8	4.5	4.5	14	2.8	25	AC10□
Y200T	3	—	67	29	53	24	33	12	5.5	5.5	19	3.2	30	AC20□
Y300T	4	82	—	41	68	35	—	14	7	7	21	4	41	AC25□, AC30□
Y400T	5	96	—	48	81.5	40	—	18	9	9	26	4	50	AC40□
Y500T	5	96	—	48	86	40	—	18	9	9	27	4.6	50	AC40□-06
Y600T	6	120	—	60	112	50	—	20	11	11	31	6.4	70	AC50, AC55, AC60, AC50B, AC55B, AC60B

Replacement parts

Description	Material	Part no.					
		Y100T	Y200T	Y300T	Y400T	Y500T	Y600T
Seal	HNBR ^{Note 2)}	Y100P-060AS ^{Note 1)}	Y200P-060S	Y300P-060S	Y400P-060S	Y500P-060S	Y600P-060S

Note 1) Y-100T comes with 2 O-rings.

Note 2) NBR seal is used for Y100T spacer because of no direct contact with fluid.

Series AC

Mounting Position for Spacer with Bracket

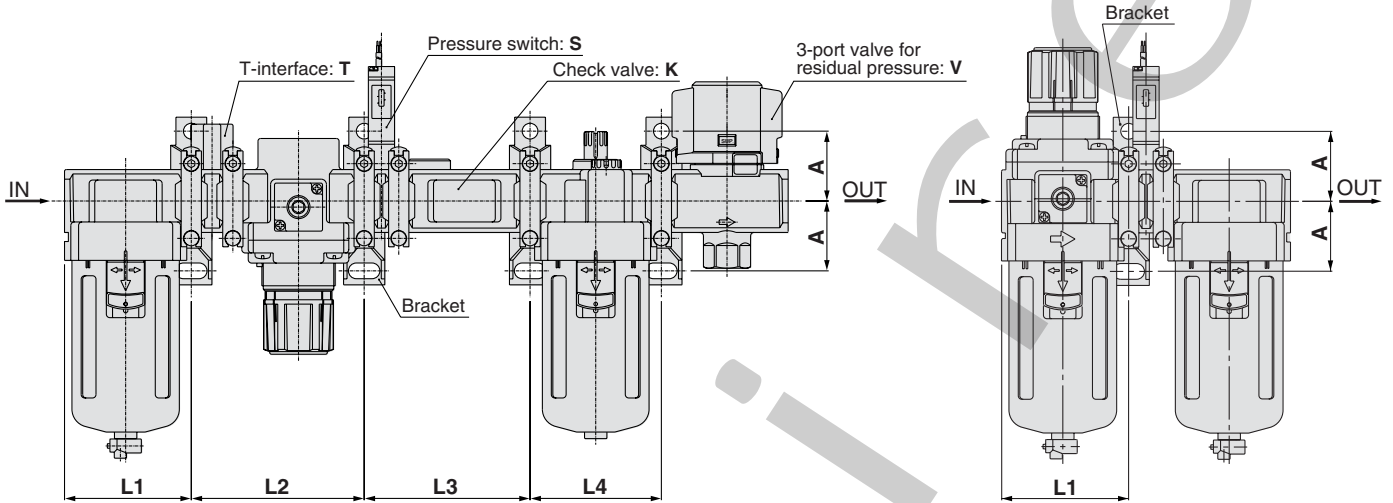

Attachment Model	K			S			T			V			KS			KT			KV				KST		
	L1	L2	L3	L1	L2	L3	L1	L2	L3	L1	L2	L3	L1	L2	L3	L1	L2	L3	L1	L2	L3	L4	L1	L2	L3
AC10	—	—	—	—	—	—	28	48	—	—	—	—	—	—	—	—	—	—	—	—	—	—	—	—	
AC20	41.5	43	43	41.5	43	41.5	61	41.5	43	43	41.5	43	57	41.5	61	43	41.5	43	43	43	41.5	61	57		
AC25	55	57	57	55	57	55	76	55	57	57	55	57	74	55	76	57	55	57	57	57	55	76	74		
AC30	55	57	57	55	57	55	76	55	57	57	55	57	74	55	76	57	55	57	57	57	55	76	74		
AC40	72.5	75	75	72.5	75	72.5	99	72.5	75	75	72.5	75	95	72.5	99	75	72.5	75	75	75	72.5	99	95		
AC40-06	—	—	—	77.5	80	77.5	104	77.5	80	80	—	—	—	—	—	—	—	—	—	—	—	—	—		
AC50	—	—	—	93	96	93	124	93	96	96	—	—	—	—	—	—	—	—	—	—	—	—	—		
AC55	—	—	—	98	96	98	124	—	—	—	—	—	—	—	—	—	—	—	—	—	—	—	—		
AC60	—	—	—	98	101	98	129	—	—	—	—	—	—	—	—	—	—	—	—	—	—	—	—		

Attachment Model	KSV				KTV				KSTV				ST		SV			STV			TV		
	L1	L2	L3	L4	L1	L2	L3	L4	L1	L2	L3	L4	L1	L2	L1	L2	L3	L1	L2	L3	L1	L2	L3
AC10	—	—	—	—	—	—	—	—	—	—	—	—	—	—	—	—	—	—	—	—	—	—	—
AC20	41.5	43	57	43	41.5	61	43	43	41.5	61	57	43	41.5	61	41.5	43	57	41.5	61	57	41.5	61	43
AC25	55	57	74	57	55	76	57	57	55	76	74	57	55	76	55	57	74	55	76	74	55	76	57
AC30	55	57	74	57	55	76	57	57	55	76	74	57	55	76	55	57	74	55	76	74	55	76	57
AC40	72.5	75	95	75	72.5	99	75	75	72.5	99	95	75	72.5	99	72.5	75	95	72.5	99	95	72.5	99	75
AC40-06	—	—	—	—	—	—	—	—	—	—	—	—	—	77.5	104	77.5	80	102	77.5	104	102	77.5	104
AC50	—	—	—	—	—	—	—	—	—	—	—	—	—	93	124	93	96	124	93	124	93	124	96
AC55	—	—	—	—	—	—	—	—	—	—	—	—	—	98	124	—	—	—	—	—	—	—	—
AC60	—	—	—	—	—	—	—	—	—	—	—	—	—	98	129	—	—	—	—	—	—	—	—

Attachment Model	K		S		V		KS		KV			KSV			SV	
	L1	L2	L1	L2	L1	L2	L1	L2	L1	L2	L3	L1	L2	L3	L1	L2
AC20A	41.5	43	41.5	41.5	43	41.5	57	41.5	43	43	41.5	57	43	41.5	57	
AC30A	55	57	55	55	57	55	74	55	57	57	55	74	57	55	74	
AC40A	72.5	75	72.5	72.5	75	72.5	95	72.5	75	75	72.5	95	75	72.5	95	
AC40A-06	—	—	77.5	77.5	80	—	—	—	—	—	—	—	—	77.5	102	

Attachment Model	S		T		V		SV		TV	
	L1	L1	L1	L2	L1	L2	L1	L2	L1	L2
AC10B	—	28	—	—	—	—	—	—	—	—
AC20B	41.5	41.5	41.5	43	41.5	57	41.5	61	—	—
AC25B	55	55	55	57	55	74	55	76	—	—
AC30B	55	55	55	57	55	74	55	76	—	—
AC40B	72.5	72.5	72.5	75	72.5	95	72.5	99	—	—
AC40B-06	77.5	77.5	77.5	80	77.5	102	77.5	104	—	—
AC50B	93	93	93	96	93	124	93	124	—	—
AC55B	98	98	—	—	—	—	—	—	—	—
AC60B	98	98	—	—	—	—	—	—	—	—

Attachment Model	S		T		V			SV			TV		
	L1	L2	L1	L2	L1	L2	L3	L1	L2	L3	L1	L2	L3
AC20C	41.5	43	41.5	43	41.5	43	43	41.5	43	57	41.5	43	61
AC25C	55	57	55	57	55	57	57	55	57	74	55	57	76
AC30C	55	57	55	57	55	57	57	55	57	74	55	57	76
AC40C	72.5	75	72.5	75	72.5	75	75	72.5	75	95	72.5	75	99
AC40C-06	77.5	80	77.5	80	77.5	80	80	77.5	80	102	77.5	80	104

Attachment Model	S		V		SV	
	L1	L1	L2	L1	L2	L1
AC20D	41.5	41.5	43	41.5	57	—
AC30D	55	55	57	55	74	—
AC40D	72.5	72.5	75	72.5	95	—
AC40D-06	77.5	77.5	80	77.5	102	—

L1: Dimensions from the end of the IN side to the center of the mounting hole for the first bracket.
 L2: Mounting hole pitch between the first and the second bracket.
 L3: Mounting hole pitch between the second and the third bracket.
 L4: Mounting hole pitch between the third and the fourth bracket.
 Refer to dimensions pages for dimension A from the center of the piping and the mounting hole.

F.R.L. Unit AC20 to 60 Made to Order Specifications

Contact P/A for detailed dimensions, specifications, and lead times.

With Digital Pressure Switch

AC20 to 60 with a digital pressure switch (Model: ISE30-□□-□□-□L) can be ordered. A digital pressure switch is mounted on the connection threads for the pressure gauge of the regulator or the filter regulator.



Specifications

Part no.		-X465
Pressure switch	Model	ISE30-□□-□□-□L
	Set pressure range	-0.1 to 1 MPa
	Set/Display resolution	0.001 MPa
	Power supply voltage	12 to 24VDC ±10%, Ripple (p-p) 10% or less (with reverse connection protection)
	Current consumption	45mA or less (70mA or less during current output)

* Pressure gauge port size: Rc 1/8

Applicable models

Model	AC20□	AC25□	AC30□	AC40□	AC40□-06	AC50□	AC55□	AC60□
Port sizes	1/8	1/4	1/4	1/4	3/4	3/4	1	1
	1/4	3/8	3/8	3/8 1/2		1		

How to Order → Refer to the next page.

Series AC

How to Order

AC 30 A F 03 D KV 12R X465 A

Air combination

Body size

20	25	30	40	50	55	60
----	----	----	----	----	----	----

Switch specifications

Symbol	Output specification
A	NPN output
B	PNP output
C	1 to 5V output
D	4 to 20mA output

With digital pressure switch (Series ISE30) Note 11

Note 11 Digital pressure switch is not mounted and is supplied loose at the time of shipment.

Description

Symbol	Description	Applicable model
1 <small>Note 8</small>	0.02 to 0.2MPa setting	AC20□ to 60□
2	Metal bowl	AC20□ to 60□
3	Lubricator with drain cock	AC20□ to 60□
6	Nylon bowl (including sight dome)	AC20□ to 60□
8	Metal bowl with level gauge	AC25□ to 60□
C	With bowl guard	AC20□
J <small>Note 9</small>	Drain guide 1/4	AC25□ to 60□
N	Non-relieving type	AC20□ to 60□
R	Flow direction: Right to left	AC20□ to 60□
W	Drain cock with barb fitting: $\phi 6 \times \phi 4$ nylon tubing	AC25□ to 60□
Z <small>Note 10</small>	Name plate and caution plate for bowl in imperial units (PSI, °F)	AC20□ to 60□

* When more than one specification is required, indicate in ascending alphanumeric order.

Note 8 The only difference from the standard specifications is the adjusting spring for the regulator. It does not restrict the setting of 0.2MPa or more.

Note 9 Without a valve function.

Note 10 For thread type NPT.

This product is for overseas use only according to the new Measurement Law. (The SI unit type is provided for use in Japan.)

Model combination

Symbol	Combination				
	Air filter	Regulator	Lubricator	Filter Regulator	Mist Separator
Nil	①	②	③	—	—
A	—	—	②	①	—
B	①	②	—	—	—
C	①	③	—	—	②
D	—	—	—	①	②

Note 1 The circled numbers indicate the order in which the units are assembled.

Thread type

Nil	Rc
N <small>Note 2</small>	NPT
F <small>Note 3</small>	G

Note 2 Drain guide is NPT1/4 (applicable to AC25 to 60), and the exhaust port for auto drain comes with $\phi 3/8"$ One-touch fitting (applicable to AC25 to 60).

Note 3 Drain guide is G1/4 (applicable to AC25 to 60).

Port size

Symbol	Port size	Body size							
		20	25	30	40	50	55	60	
01	1/8	●	—	—	—	—	—	—	
02	1/4	●	●	—	—	—	—	—	
03	3/8	—	●	●	●	—	—	—	
04	1/2	—	—	—	●	—	—	—	
06	3/4	—	—	—	●	●	—	—	
10	1	—	—	—	—	●	●	●	

Accessories

Symbol	Description	Applicable model
Nil	—	—
C	With float type auto drain (N.C.) <small>Note 1</small>	AC20□ to 60□
D	With float type auto drain (N.O.) <small>Note 1</small>	AC25□ to 60□

Note 1 Applicable tube O.D. for auto drain connection should be $\phi 3/8"$ in case NPT thread port is chosen.

Note 12 Consult P/A for detailed dimensions and available attachments and options.

Attachment

Symbol	Description	Attachment mounting position	Applicable model	Port size for intermediate air release
Nil	None	—	—	—
K	Check valve	AF+AR+[K]+AL	AC20 to 40	AC20□: 1/8 AC25□: 1/4 AC30□: 1/4 AC40□: 3/8
		AW+[K]+AL	AC20A to 40A	
T	T-interface	AF+[T]+AR+AL	AC20 to 60	AC20□: 1/8 AC25□: 1/4 AC30□: 1/4 AC40□: 3/8 AC50□: 3/8 AC55□: 1/2 AC60□: 1/2
		AF+[T]+AR	AC20B to 60B	
		AF+AFM+[T]+AR	AC20C to 40C	
V	3-port valve for residual pressure release	AF+AR+AL+[V]	AC20 to 50	—
		AW+AL+[V]	AC20A to 40A	
		AF+AR+[V]	AC20B to 50B	
		AF+AFM+AR+[V]	AC20C to 40C	
		AW+AFM+[V]	AC20D to 40D	

* When more than one attachment is required, order in alphabetical order.

* Piping adapter, pressure switch with piping adapter, and cross interface need to be ordered separately.

* Contact P/A when using a pressure switch and T-interface together for AC□B.

* The bracket position varies depending on the T-interface or pressure switch mounting.

Refer to the table on page 19 for standard bracket position.