

End Lock Cylinder

Series **CBM2** / $\varnothing 20, \varnothing 25, \varnothing 32, \varnothing 40$

Series **CBA1** / $\varnothing 40, \varnothing 50, \varnothing 63, \varnothing 80, \varnothing 100$

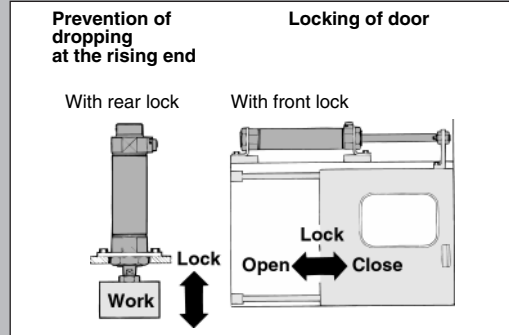
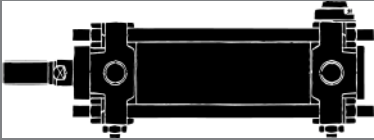

Maintains the cylinder's original position even if the air supply is interrupted.

When air is discharged at the stroke end position, the lock engages to maintain the piston rod in that position.

Has the same installation dimensions as the standard cylinder (Series CM2/CA1). [Excluding those with a CBM2 air cushion.]

Non-locking and locking styles are standard for manual release.

Variations

Series	Action	Rod style	Cushion	Basic Magnet	Variations			Bore size (mm)	Page
					W/ rod boot	Clean series	Copper free		
Standard Series CBM2 	Double acting	Single rod	Rubber bumper	●	●	●	20 25 32 40	3.8-4	
			Air cushion	●	●	●			
Standard Series CBA1 	Double acting	Single rod	Air cushion	●	●	—	40 50 63 80 100	3.8-12	
			—	●	●	—			

Applicable Auto Switch Model

Auto switch	Mounting of auto switch	Applicable auto switches	
		Series CBM2	Series CBA1
Reed switch	Band mounting	D-C7/C8, D-C73C/C80C, D-B5/B6, D-B59W, D-A3□A/A44A	D-B5/B6, D-B59W, D-A3/A44
	Tie rod mounting	—	D-A5/A6, D-A59W, D-A3□C/A44C
Solid state switch	Band mounting	D-H7, D-H7□W, D-H7□F, D-H7BAL, D-H7C, D-G5NTL, D-G39A/K39A	D-G5□/K59, D-G5NTL, D-G5□W/K59W, D-G5BAL, D-G59F, D-G39/K39
	Tie rod mounting	—	D-F5□/J5□, D-F5NTL, D-F5□W/J59W, D-F5BAL, D-F59F, D-G39C/K39C

Made to Order Specifications

Refer to p.5.4-1 for further information on made to order specifications of series CBM2 and CBA1.

- CL
- MLG
- CNA
- CNG
- MNB
- CNS
- CLS
- CB**
- CV/MVG
- CXW
- CXS
- CXT
- MX
- MXU
- MXH
- MXS
- MXQ
- MXF
- MXW
- MXP
- MG
- MGP
- MGQ
- MGG
- MGC
- MGF
- MGZ
- CY
- MY

Series CB Prior to Use

⚠ Precautions

Be sure to read before handling. Refer to p.0-39 to 0-46 for Safety Instructions and common precautions.

Use Recommended Air Pressure Circuit.

⚠ Caution

● It is necessary to make it lock and unlock properly.

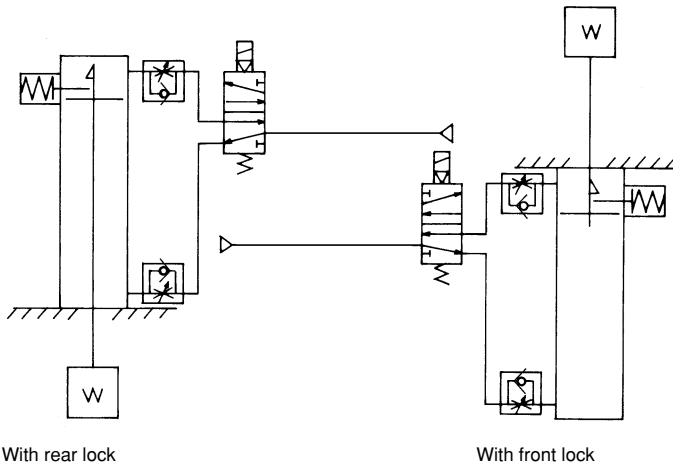

With rear lock

With front lock

Operating Precautions

⚠ Caution

① **Do not use a 3 position solenoid valve.**

Avoid using this cylinder in combination with a 3 position solenoid valve (particularly the closed centre metal seal style). If air pressure becomes sealed inside the port on the side that contains the lock mechanism, the lock will not engage. Even if the lock is engaged at first, the air that leaks from the solenoid valve could enter the cylinder and cause the lock to disengage as time elapses.

② **Back pressure is necessary for unlocking**

Before starting, make sure that air is supplied to the side that is not equipped with a lock mechanism as shown in the diagram above (or the side on which the piston rod is unlocked, if both sides are equipped with a lock). Otherwise, the lock may not disengage.

(☞ Refer to "Regarding lock disengagement".)

③ **Disengage the lock before installing or adjusting the cylinder.**

The lock could become damaged if the cylinder is installed with its lock engaged.

④ **Operate the cylinder at a load ratio of 50% or less.**

The lock might not disengage or might become damaged if a load ratio of 50% is exceeded.

⑤ **Do not synchronize multiple cylinders.**

Do not operate two or more end lock cylinders synchronized to move a single workpiece because, one of the cylinder locks may not be able to disengage when required.

⑥ **Operate the speed controller under meter-out control.**

If operated under meter-in control, the lock might not disengage.

⑦ **On the side that has a lock, make sure to operate at the stroke end of the cylinder.**

The lock might not engage or disengage if the piston in the cylinder has not reached the stroke end.

Operating Pressure

⚠ Caution

① Supply air pressure of 0.15MPa or higher to the port on the side that has the lock mechanism, as it is necessary for disengaging the lock.

The Exhaust Air Speed

⚠ Caution

① The lock will engage automatically if the air pressure at the port on the side that has the lock mechanism becomes 0.05MPa or less. Be aware that if the piping on the side that has the lock mechanism is narrow and long, or if the speed controller is located far from the cylinder port, the exhaust air speed could become slower, involving a longer time for the lock to engage. A similar result will ensue if the silencer that is installed on the exhaust port of the solenoid valve becomes clogged.

The Relationship between the Lock and the Cushion

⚠ Caution

① When the cushion valve on the side with the lock mechanism is fully closed or almost closed, the piston rod might not be able to reach the stroke end. Thus, the lock will not engage. Furthermore, if the lock becomes engaged when the cushion valve is almost fully closed, it might not be possible for the lock to disengage. Therefore, the cushion valve must be adjusted properly.

Lock Disengagement

⚠ Warning

① To disengage the lock, make sure to supply air pressure to the port on the side without a lock mechanism, thus preventing the load from being applied to the lock mechanism. (Refer to the recommended air pressure circuit.) If the lock is disengaged when the port on the side that does not contain a lock mechanism is in the exhausted state and the load is being applied to the lock mechanism, undue force will be applied to the lock mechanism, and it may damage the lock mechanism. Also, it could be extremely dangerous, because the piston rod could move suddenly.

Manual Disengagement

⚠ Caution

① Non-locking style manual release

Insert the bolt, which is provided as an accessory part, through the rubber cap (it is not necessary to remove the rubber cap). Screw the bolt into the lock piston and pull the bolt to disengage the lock. Releasing the bolt will re-engage the lock. The bolt size, pulling force, and the stroke are listed below.

Bore size (mm)	Thread size	Pulling force	Stroke (mm)
20, 25, 32	M2.5 X 25ℓ	4.9N	2
40, 50, 63	M3 X 3ℓ	10N	3
80, 100	M5 X 40ℓ	24.5N	3

Bolt should be detached under normal operation, otherwise it may cause malfunction of the locking feature.

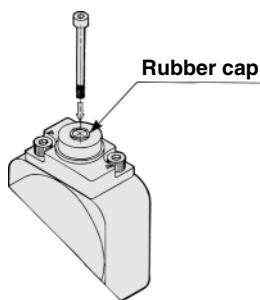

② Locking style manual release

Push the M/O knob and turn it 90° counterclockwise. The lock disengages when the ▲ mark on the cap is aligned with the ▼ OFF mark on the M/O knob (and the lock will remain disengaged). To engage the lock, push the M/O knob all the way in and turn it 90° clockwise to align the ▲ mark on the cap with the ▼ ON mark on the M/O knob. At this time, make sure that the knob stops by clicking into place. Unless the knob has stopped properly, it could prevent the lock from engaging.

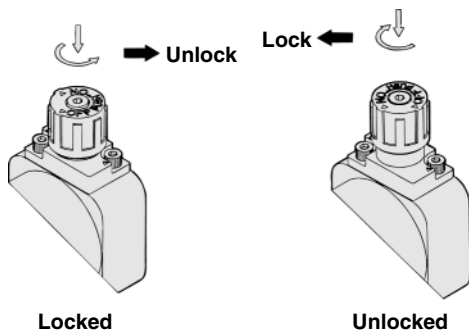

Operation Principles

● For the rear lock (the same as the front lock)

① When the piston rod nears the stroke end, the tapered portion (* mark) at one end of the piston rod pushes the lock piston upward.

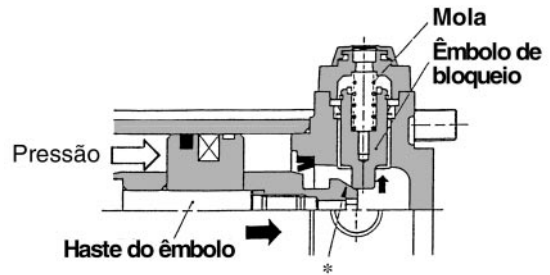

② The lock piston is pushed further upward.

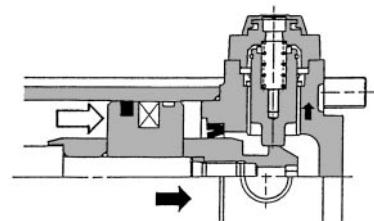

③ The lock becomes engaged as the lock piston falls into the groove portion of the piston rod. (A spring force keeps the lock piston pushed down.) At this time, the port on the head side is in the discharged state and is at atmospheric pressure.

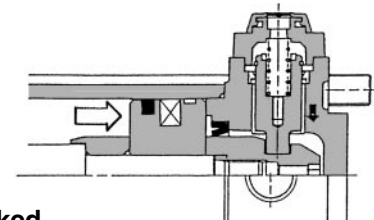

④ When air pressure is supplied to the head side, this pressure pushes the lock piston upward to disengage the lock.

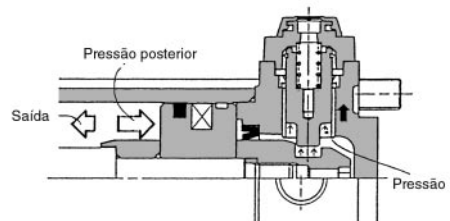

⑤ As the lock has been disengaged, the cylinder moves forward.

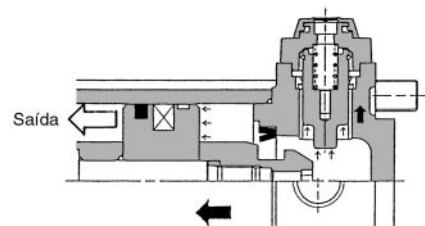

- CL
- MLG
- CNA
- CNG
- MNB
- CNS
- CLS
- CB**
- CV/MVG
- CXW
- CXS
- CXT
- MX
- MXU
- MXH
- MXS
- MXQ
- MXF
- MXW
- MXP
- MG
- MGP
- MGQ
- MGG
- MGC
- MGF
- MGZ
- CY
- MY

End Lock Cylinder

Series CBM2

ø20, ø25, ø32, ø40

How to Order

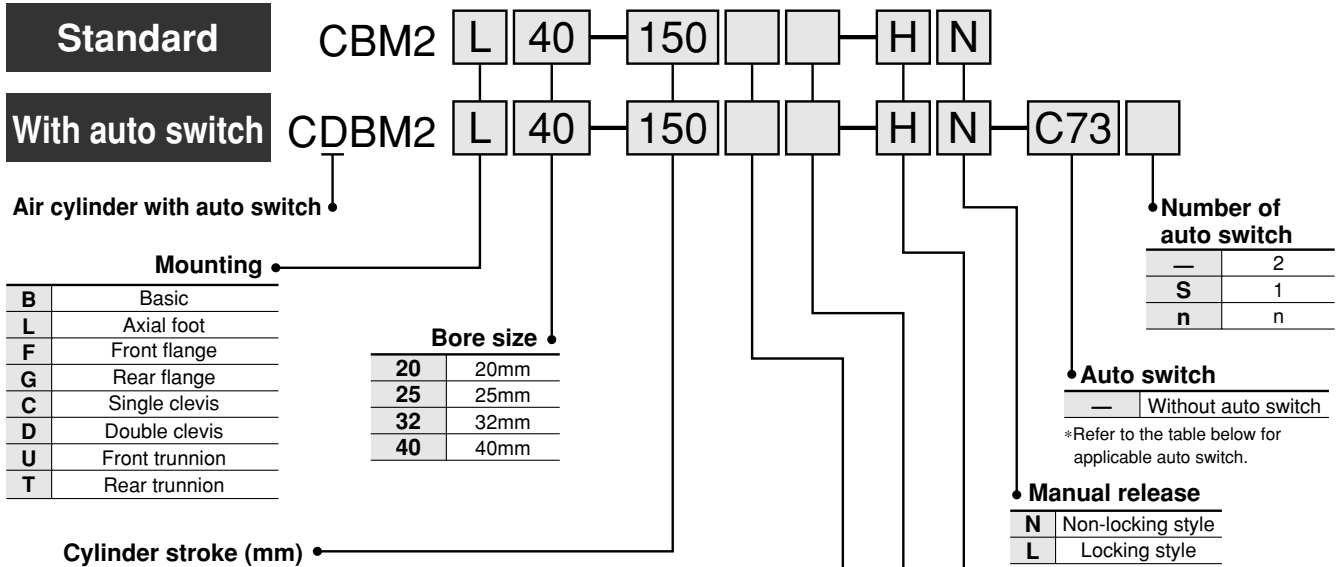

Cylinder stroke (mm)
(Refer to the standard stroke table on p.3.8-5.)

Applicable auto switches/Refer to p.5.3-2 for further information on auto switch.

Style	Special function	Electrical entry	Indicator	Wiring (Output)	Load voltage		Model	Lead wire* (m)				Applicable load								
					DC	AC		0.5 (—)	3 (L)	5 (Z)	— (N)									
Reed switch	—	Grommet	Yes	3 wire (Equiv. to NPN)	—	5V	—	C76	●	●	—	—	IC							
						12V	100V	C73	●	●	●	—	—	Relay PLC						
						5V	100V or less	C80	●	●	—	—	—	IC						
						12V	—	B53	●	●	●	—	—	PLC						
						12V	100V 200V	B54	●	●	●	—	—	—						
						12V	200V or less	B64	●	●	—	—	—	Relay PLC						
						Connector	No	2 wire	Yes	12V	—	C73C	●	●	●	●	—	Relay PLC		
												5V	24V or less	C80C	●	●	●	●	IC	
												12V	—	A33A	—	—	—	●	—	PLC
						Conduit terminal	Yes	2 wire	No	12V	—	A34A	—	—	—	●	—	PLC		
												12V	100V 200V	A44A	—	—	—	●	—	Relay PLC
												—	—	B59W	●	●	—	—	—	
Solid state switch	Diagnosis indicator (2 colour)	Grommet	Yes	3 wire (NPN)	—	5V	—	H7A1	●	●	○	—	IC							
						12V	—	H7A2	●	●	○	—	IC							
						2 wire	12V	H7B	●	●	○	—	—							
								H7C	●	●	●	●	—	—						
						Connector	No	2 wire	Yes	5V	12V	G39A	—	—	—	●	—			
												K39A	—	—	—	●	—	—		
						Conduit terminal	Yes	2 wire	No	5V	12V	H7NW	●	●	○	—	IC			
												H7PW	●	●	○	—	—			
						Water resist. (2 colour)	Grommet	2 wire	Yes	12V	—	H7BW	●	●	○	—	—			
												H7BA	—	●	○	—	—			
						With timer	Grommet	3 wire (NPN)	No	5V	12V	G5NT	—	●	○	—	IC			
												H7NF	●	●	○	—	—			
Diagnosis output (2 colour)	Grommet	4 wire (NPN)	No	5V	12V	H7LF	●	●	○	—	—									

* Symbols for lead wire length 0.5m--- EX.)C80C 5m---Z EX.)C80CZ 3m---L C80CL ---N C80CN

☆ Solid state switches marked with "○" are manufactured upon receipt of order.

Maintains the cylinder's original position even if the air supply is interrupted.

When air is discharged at the stroke end position, the lock engages to maintain the rod in that position.

Non-locking and locking styles are standard for manual release.

Auto switches can be mounted.



Specifications

Model	Air pressure style	
Action	Double acting single rod	
Fluid	Air	
Proof pressure	1.5MPa	
Max. pressure	1.0MPa	
Min. pressure	0.15MPa*	
Ambient and fluid temperature	Without auto switch: -10°C to 70°C (No freezing) With auto switch: -10°C to 60°C (No freezing)	
Cushion	Rubber bumper, Air cushion	
Lubrication	Not required (Non-lube)	
Thread tolerance	JIS 2nd class	
Stroke tolerance	$^{+1.4}_0$	
Piston speed	Rubber bumper	50 to 750mm/s
	Air cushion	50 to 1000mm/s
Mounting	Basic, Axial foot, Front flange, Rear flange, Single clevis, Double clevis, Rear trunnion, Front trunnion	

* At 0.05MPa except for lock part.

Lock Specifications

Lock position	Rear end, Front end, Both ends			
Holding force (Max.) (N)	ø20	ø25	ø32	ø40
	215	330	550	860
Back rush	1 mm or less			
Manual release	Non-locking style, Locking style			

Allowable Kinetic Energy

Bore size (mm)		20	25	32	40
Rubber bumper	Allowable kinetic energy (J)	0.27	0.4	0.65	12
	Effective cushion length(mm)	11.0	11.0	11.0	11.8
Air cushion	Cushion sectional area(cm ²)	2.09	3.30	5.86	9.08
	Absorbable kinetic energy J	0.54	0.78	1.27	2.35

Standard Stroke

Bore size (mm)	Standard stroke (mm)	Long stroke* (mm)	Available maximum stroke (mm)
20	25, 50, 75, 100, 125, 150, 200, 250 300	400	1000
25		450	
32		450	
40		500	

* The long-stroke style is only applicable to the axial foot style and the front flange style.
For other applications that exceed the mounting support bracket and long-stroke limitations, the maximum stroke that can be used is determined by the stroke selection table on p.0-21.

Minimum Strokes for Auto Switch Mounting

Auto switch	Number of auto switches (mm)				
	2 pcs.		n pcs.		1 pc.
	Mounting different sides	Mounting same side	Mounting different sides	Mounting same side	
D-C7 D-C8	15	50	15+45($\frac{n-2}{2}$)	50+45(n-2)	10
D-H7□ D-H7□W D-H7BAL D-H7NF	15	60	(n=2, 4, 6...)	60+45(n-2)	10
D-C73C D-C80C D-H7C	15	65	15+50($\frac{n-2}{2}$) (n=2, 4, 6...)	65+50(n-2)	10
D-H7LF	20	65	20+50($\frac{n-2}{2}$) (n=2, 4, 6...)		10
D-B5/B6 D-G5NTL	15	75	15+50($\frac{n-2}{2}$) (n=2, 4, 6...)	75+55(n-2)	10
D-B59W	20	75	20+50($\frac{n-2}{2}$) (n=2, 4, 6...)		15
D-A3□A D-G39A D-K39A D-A44A	35	100	35+30(n-2)	100+100(n-2)	10



Made to Order Specifications

Refer to p.5.4-1 for made to order specifications of series CBM2.

CL
MLG
CNA
CNG
MNB
CNS
CLS
CB
CV/MVG
CXW
CXS
CXT
MX
MXU
MXH
MXS
MXQ
MXF
MXW
MXP
MG
MGP
MGQ
MGG
MGC
MGF
MGZ
CY
MY

Series CBM2

Accessories/Details are the same as that of standard style of series CM2. Refer to p.1.4-19 and 1.4-20.

Standard equipment	Mounting nut, Rod end nut, Clevis pin, Lock release bolt (N type only)
Option	Single knuckle joint, Double knuckle joint (with pins)

* Nuts for mounting are not equipped to single clevis style and double clevis style.

Rod Boot Materials

Symbol	Material	Max. ambient temp.
J	Nylon tarpaulin	60°C
K	Heat resistant tarpaulin	110°C*

* Maximum ambient temperature for the rod boot itself

Weight

(kg)

Bore size (mm)		20	25	32	40
Basic weight	Basic	0.14	0.21	0.28	0.56
	Axial foot	0.29	0.37	0.44	0.83
	Flange	0.20	0.30	0.37	0.68
	Single clevis	0.18	0.25	0.32	0.65
	Double clevis	0.19	0.27	0.33	0.69
	Trunnion	0.18	0.28	0.34	0.66
Additional weight per 50 strokes		0.04	0.06	0.08	0.13
Accessor	Clevis pivot (with pins)	0.07	0.07	0.14	0.14
	Single knuckle joint	0.06	0.06	0.06	0.23
	Double knuckle joint (with pins)	0.07	0.07	0.07	0.20

Additional Weight of Lock

(kg)

Bore size (mm)		20	25	32	40
Manual release non-locking style (N)	Rear lock (H)	0.02	0.02	0.02	0.04
	Front lock (R)	0.01	0.01	0.01	0.02
	Lock on both sides (W)	0.03	0.03	0.03	0.06
Manual release locking style (L)	Rear end lock (H)	0.03	0.03	0.03	0.06
	Front end lock (R)	0.02	0.02	0.02	0.04
	Double end lock (W)	0.05	0.05	0.05	0.10

Calculation example: **CBM2L32-100-HN**

- Basic weight.....0.44(Foot style ø32)
 - Additional weight.....0.08/50 strokes
 - Cylinder stroke.....100 strokes
 - Lock weight.....0.02(Rear lock, Manual release non-lock style)
- $$0.44+0.08 \times 100/50+0.02=0.62\text{kg}$$

Auto Switch Mounting Bracket Part No.

Model	Bore size (mm)			
	20	25	32	40
D-C7/C8 D-H7	BM2-020	BM2-025	BM2-032	BM2-040
D-B5/B6 D-G5NTL	BA2-020	BA2-025	BA2-032	BA2-040
D-A3□A/A44A D-G39A/K39A	BM3-020	BM3-025	BM3-032	BM3-040



Stainless steel mounting bolt set

The set of stainless steel mounting screws described below is available and can be used depending on the operating environment. (The band for auto switches must be ordered separately, as it is not included.)

BBA4: For D-C7/C8/H7

- The stainless steel bolts described above are used when the D-H7BAL type switch is shipped mounted on a cylinder. When the switches are shipped as individual parts, the BBA4 set are included.

Construction

Rear lock

Manual release locking style: Suffix L

Manual release non-locking style: Suffix N

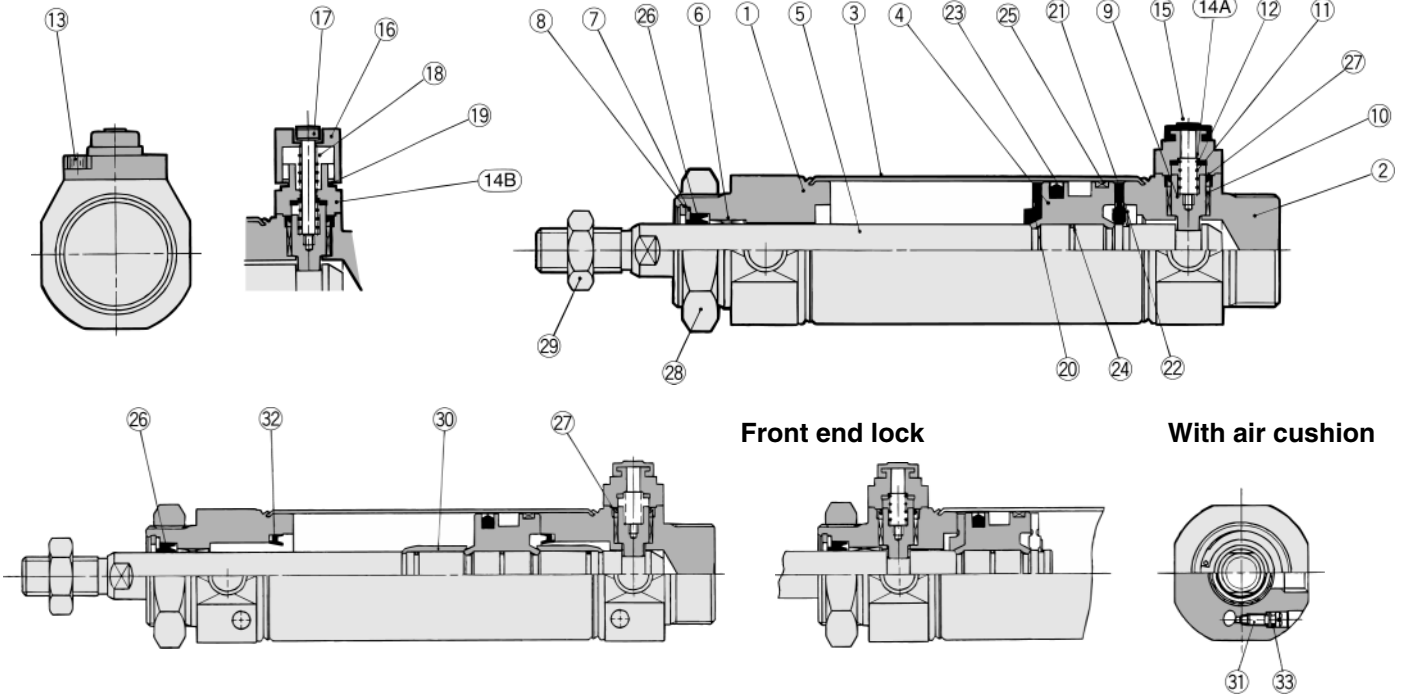

Component Parts

No.	Description	Material	Notes
①	Rod cover	Aluminum alloy	White anodized
②	Head cover	Aluminum alloy	White anodized
③	Cylinder tube	Stainless steel	
④	Piston	Aluminum alloy	Chromate
⑤	Piston rod	Carbon steel	Hard chrome plated
⑥	Bushing	Sintered oil impregnated metal	
⑦	Packing retainer	Rolled steel	Nickel plated
⑧	Snap ring	Carbon steel	Nickel plated
⑨	Lock piston	Carbon steel	Hard chrome plated, Heat treated
⑩	Lock bushing	Zinc bronze die cast	
⑪	Lock spring	Steel wire	Zinc chromated
⑫	Bumper	Urethane	
⑬	Hex. socket head cap screw	Alloy steel	Black zinc chromated
14A	Cap A	Aluminum die cast	Black painting
14B	Cap B	Carbon steel	Tuffride
15	Rubber cap	Synthetic rubber	
16	M/O knob	Zinc die cast	Black painting
17	M/O bolt	Alloy steel	Black zinc chromated
18	M/O spring	Steel wire	Zinc chromated
19	Stopper ring	Carbon steel	Zinc chromated
20	Bumper A	Urethane	
21	Bumper B	Urethane	
22	Snap ring	Stainless steel	
23	Piston seal	NBR	
24	Piston gasket	NBR	
25	Wear ring	Resin	
28	Mounting nut	Carbon steel	Nickel plated
29	Rod end nut	Carbon steel	Nickel plated
30	Cushion ring	Rolled steel	Electroless nickel plated
31	Cushion valve	Rolled steel	Electroless nickel plated
32	Cushion seal	NBR	

Component Parts

No.	Description	Material	Notes
25	Rod seal	NBR	
27	Lock piston seal	NBR	
33	Cushion valve seal	NBR	

Replacement Parts: Seal Kits (With Single End Lock)

Bore size (mm)	20	25	32	40
Order No.	CBM2-20-PS	CBM2-25-PS	CBM2-32-PS	CBM2-40-PS

With Double End Lock

Order No.	CBM2-20-PS-W	CBM2-25-PS-W	CBM2-32-PS-W	CBM2-40-PS-W
-----------	--------------	--------------	--------------	--------------

* The seal kit is a set of 25 and 27. Order with the order numbers for respective tube bore size. (Apart from 33.)

How to Replace Rod Seal

Removal:

- Using a pair of internal C-clip pliers, remove snap ring A. By pulling out the piston rod while covering the rod cover port with your finger, packing retainer A and rod seal C will come out.

Installation:

- Thoroughly apply grease on the rod seal and install rod seal C, packing retainer B, and snap ring A, in that order.

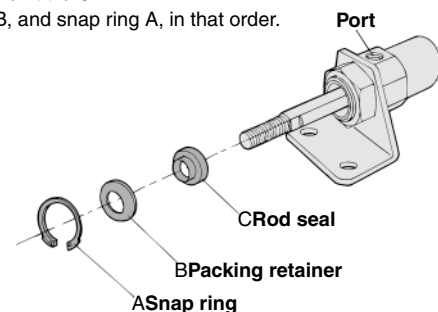

CL
MLG
CNA
CNG
MNB
CNS
CLS
CB
CV/MVG
CXW
CXS
CXT
MX
MXU
MXH
MXS
MXQ
MXF
MXW
MXP
MG
MGP
MGQ
MGG
MGF
MGZ
CY
MY

Series CBM2

Basic (The dimensions are common regardless of the lock positions, rear, front or both ends.)

With rear end lock: **CBM2B** **Bore size** **Stroke** -HN

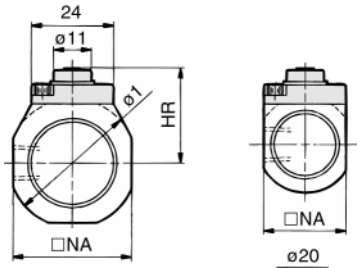

Manual release non-locking style (Additional symbol: N)

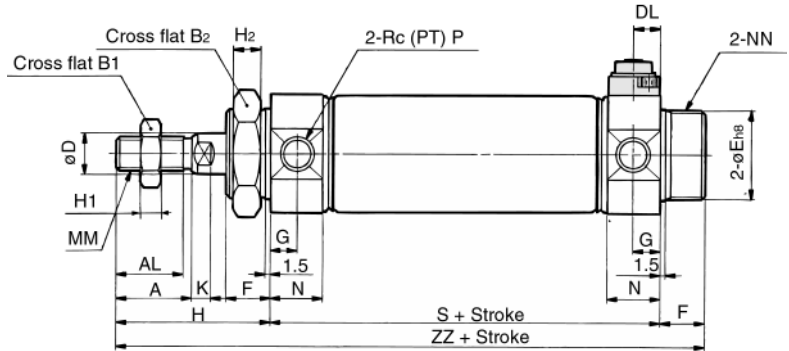

With front end lock: **CBM2B** **Bore size** **Stroke** -RN

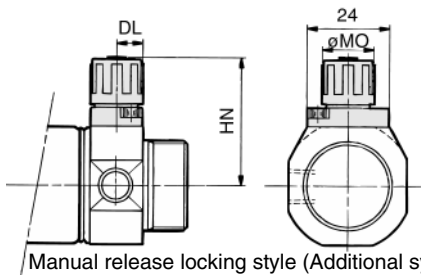

Manual release locking style (Additional symbol: L)

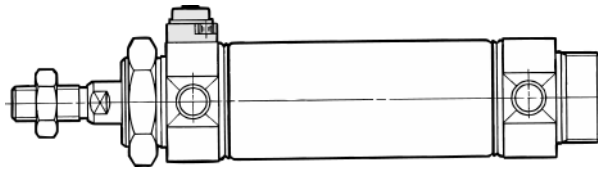

With double end lock: **CBM2B** **Bore size** **Stroke** -WN

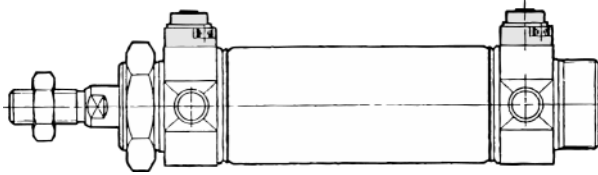

With rod boot

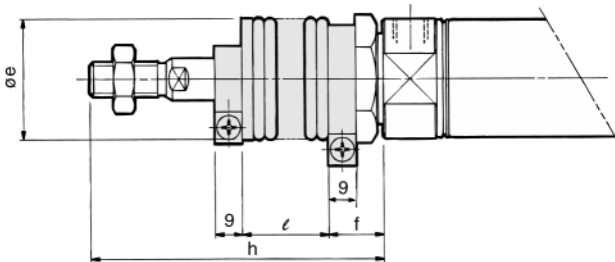

Symbol	Stroke range	A	AL	B ₁	B ₂	D	DL	Eh8	F	G	H	H ₁	H ₂	HR	HN (MAX)	I	K	MM	MO	N	NA	NN	P	S	ZZ
20	Up to 300	18	15.5	13	26	8	7.5	20 ⁰ _{-0.033}	13	8	41	5	8	22.3	34	28	5	M8	15	15	24	M20 X 1.5	1/8	62	116
25	Up to 300	22	19.5	17	32	10	7.5	26 ⁰ _{-0.033}	13	8	45	6	8	25.3	37	33.5	5.5	M10 X 1.25	15	15	30	M26 X 1.5	1/8	62	120
32	Up to 300	22	19.5	17	32	12	7.5	26 ⁰ _{-0.033}	13	8	45	6	8	27.6	39.3	37.5	5.5	M10 X 1.25	15	15	34.5	M26 X 1.5	1/8	64	122
40	Up to 300	24	21	22	41	14	10.7	32 ⁰ _{-0.039}	16	11	50	8	10	33.6	47.8	46.5	7	M14 X 1.5	19	21.5	42.5	M32 X 2	1/4	88	154

With rod boot

Symbol	e	f	h							l						
			1 to 50	51 to 100	101 to 150	151 to 200	201 to 300	301 to 400	401 to 500	1 to 50	51 to 100	101 to 150	151 to 200	201 to 300	301 to 400	401 to 500
20	35	17	68	81	93	106	131	156	—	12.5	25	37.5	50	75	100	—
25	35	17	72	85	97	110	135	160	185	12.5	25	37.5	50	75	100	125
32	35	17	72	85	97	110	135	160	185	12.5	25	37.5	50	75	100	125
40	46	19	77	90	102	115	140	165	190	12.5	25	37.5	50	75	100	125

* Refer to p.1.4-19 and 1.4-20 for further information of rod end nut and accessories.

Dimensions: With Mounting Bracket (Refer to p.3.8-8 for other dimensions.)

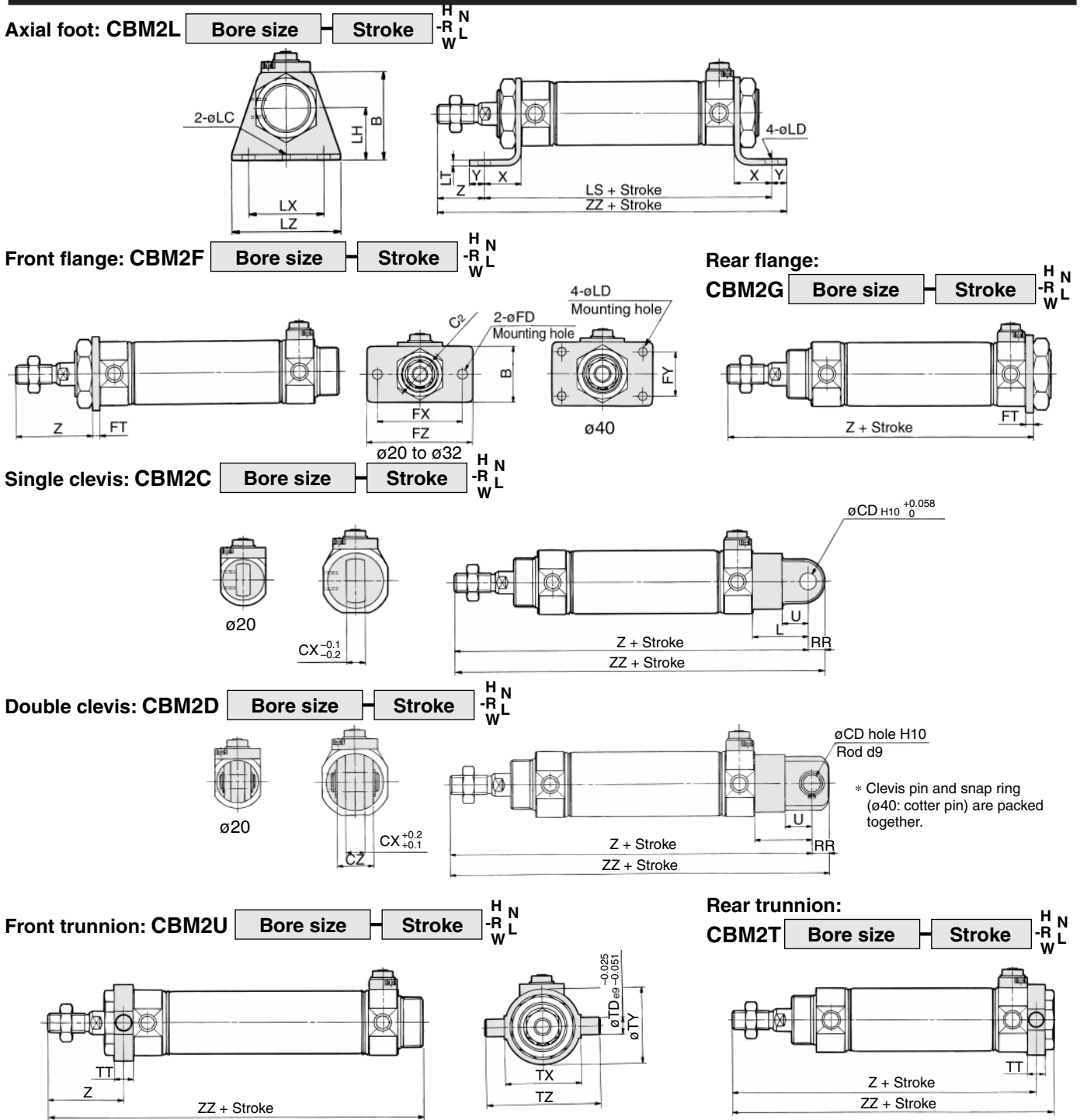

- CL
- MLG
- CNA
- CNG
- MNB
- CNS
- CLS
- CB
- CV/MVG
- CXW
- CXS
- CXT
- MX
- MXU
- MXH
- MXS
- MXQ
- MXF
- MXW
- MXP
- MG
- MGP
- MGQ
- MGG
- MGC
- MGF
- MGZ
- CY
- MY

Bore (mm)	Axial foot												Flange								Clevis												Trunnion											
	Stroke range	B	LC	LD	LH	LS	LT	LX	LZ	X	Y	Z	ZZ	Stroke range	Front	Rear	B	C ₂	FD	FT	FX	FY	FZ	Z		Stroke range	CD	CX	CZ	L	RR	U	Z	ZZ	Stroke range	TD	TT	TX	TY	Z		ZZ		
																								Front	Rear															Front	Rear	Front	Rear	Front
20	≤400	40	4	6.8	25	102	3.2	40	55	20	8	21	131	≤400	≤300	34	30	7	4	60	—	75	37	107	≤300	9	10	19	30	9	14	133	142	≤300	8	10	32	32	52	36	108	116	118	
25	≤450	47	4	6.8	28	102	3.2	40	55	20	8	25	135	≤450	≤300	40	37	7	4	60	—	75	41	111	≤300	9	10	19	30	9	14	137	146	≤300	9	10	40	40	60	40	112	120	122	
32	≤450	47	4	6.8	28	104	3.2	40	55	20	8	25	137	≤450	≤300	40	37	7	4	60	—	75	41	113	≤300	9	10	19	30	9	14	139	148	≤300	9	10	40	40	60	40	114	122	124	
40	≤500	54	4	7	30	134	3.2	55	75	23	10	27	171	≤500	≤300	52	47.3	7	5	66	36	82	45	143	≤300	10	15	30	39	11	18	177	188	≤300	10	11	53	53	77	44.5	143.5	154	154	

* The dimensions other than indicated below are the same as those of indicated on p.3.8-8.

Precautions for Using Trunnion Style and Flange Style

1. Trunnion Style

Be aware of interference between the trunnion pin and the fitting because, the trunnion pin and the port come extremely close to each other in the following styles: ① Front end trunnion style with the front end lock, ② Rear end trunnion style with the rear end lock, and ③ With double end lock.

2. Flange style (ø20 to ø32)

Be aware that the cylinder mounting bolts and the fitting could come in contact with each other in the following styles: ① Front flange style with the front end lock, ② Rear end flange style with the rear end lock, and ③ With double end lock.

➔ Changed port position style: refer to the "Made to Order Specifications" on p.5.4-1.

Series CBM2

With Air Cushion (Refer to p.3.8-8 and 3.8-9 for other dimensions.)

Basic

With rear lock: **CBM2B** Bore size Stroke A-HN

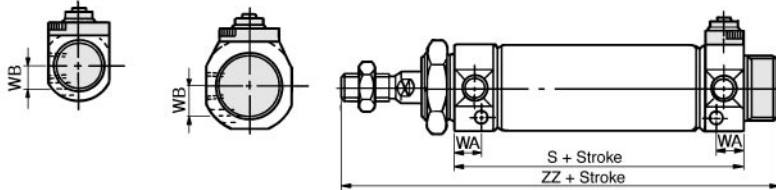

With air cushion

(mm)

Bore size (mm)	S			WA	WB	ZZ		
	Rear lock	Front lock	Double lock			Rear lock	Front lock	Double lock
20	72	73	83	11.5	8.5	126	127	137
25	72	73	83	11.5	10	130	131	141
32	72	75	83	11.5	11.5	130	133	141
40	93	96	101	14.5	15	159	162	167

Axial foot: **CBM2L** Bore size Stroke A^H_R_L^N_W

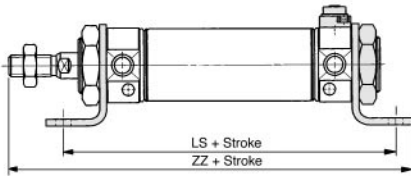

Rear flange: **CBM2G** Bore size Stroke A^H_R_L^N_W

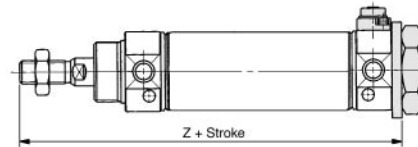

Front flange: **CBM2F** Bore size Stroke A^H_R_L^N_W

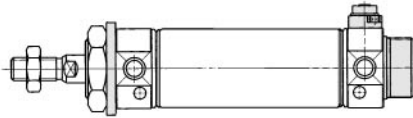

Double clevis: **CBM2D** Bore size Stroke A^H_R_L^N_W

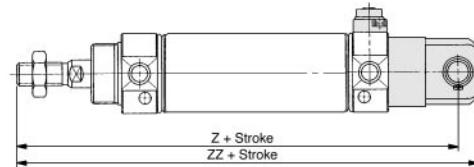

Single clevis: **CBM2C** Bore size Stroke A^H_R_L^N_W

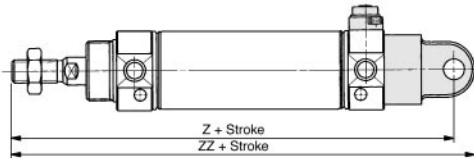

Rear trunnion: **CBM2T** Bore size Stroke A^H_R_L^N_W

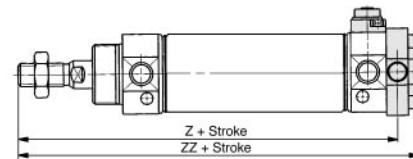

Front trunnion: **CBM2U** Bore size Stroke A^H_R_L^N_W

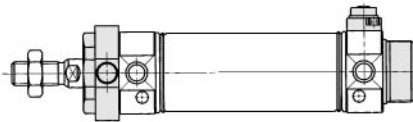

(mm)

Bore size (mm)	Axial foot						Rear flange		
	LS			ZZ			Z		
	Rear lock	Front lock	Double lock	Rear lock	Front lock	Double lock	Rear lock	Front lock	Double lock
20	112	113	123	141	142	152	117	118	128
25	112	113	123	145	146	156	121	122	132
32	112	115	123	145	148	156	121	124	132
40	139	142	147	176	179	184	148	151	156

Bore size (mm)	Clevis						Rear trunnion					
	Z			ZZ			Z			ZZ		
	Rear lock	Front lock	Double lock	Rear lock	Front lock	Double lock	Rear lock	Front lock	Double lock	Rear lock	Front lock	Double lock
20	143	144	154	152	153	163	118	119	129	128	129	139
25	147	148	158	156	157	167	122	123	133	132	133	143
32	147	150	158	156	159	167	122	125	133	132	135	143
40	182	185	190	193	196	201	148.5	151.5	156.5	159	162	167

Auto Switch Mounting Position and Mounting Height

Reed switch

D-C7/C8

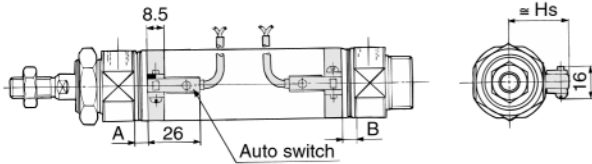

Solid state switch

D-H7□/H7□W/H7□F/H7BAL

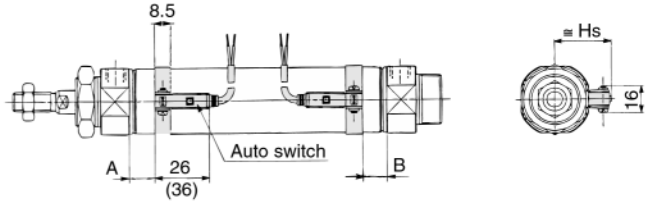

* Factors in parentheses are of D-H7LF.

D-B5/B6/B59W

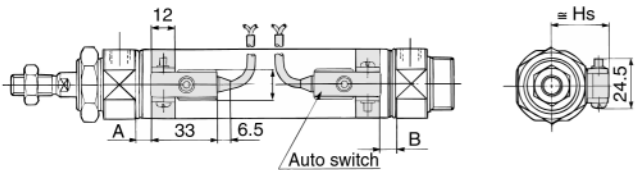

D-G5NTL

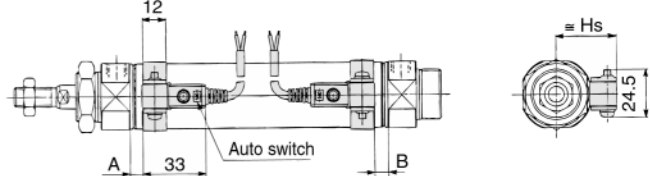

D-A33A/A34A

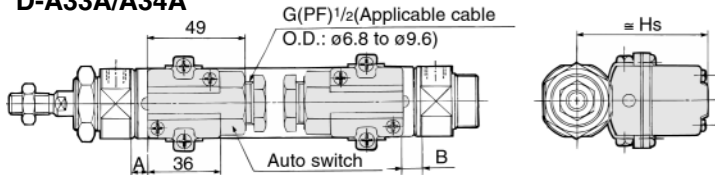

D-G39A/K39A

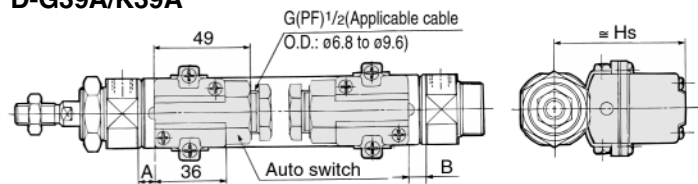

D-A44A

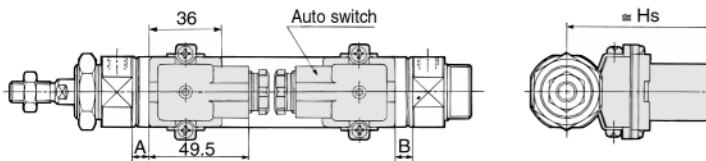

D-H7C

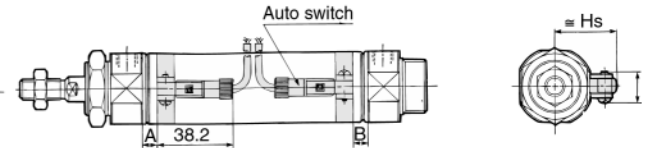

D-C73C/C80C

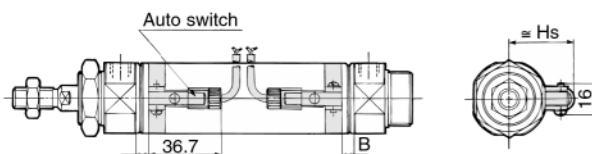

Auto Switch Setting Positions

(mm)

Model	D-B5 D-B6		D-C7 D-C8 D-C73C D-C80C		D-B59W		D-A3□A D-G39A D-K39A D-A44A		D-H7□ D-H7C		D-H7□W D-H7BAL D-H7□F		D-G5NTL	
	A	B	A	B	A	B	A	B	A	B	A	B	A	B
ø20	1(0)	0(0)	7(5)	6(4)	4(2)	3(1)	0.5(0)	0(0)	6(4)	5(3)	4.5(2.5)	3.5(1.5)	2.5(0.5)	1.5(0)
ø25	1(0)	0(0)	7(5)	6(4)	4(2)	3(1)	0.5(0)	0(0)	6(4)	5(3)	4.5(2.5)	3.5(1.5)	2.5(0.5)	1.5(0)
ø32	2(0)	1(0)	8(6)	7(5)	5(3)	4(2)	1.5(0)	0.5(0)	7(5)	6(4)	5.5(3.5)	4.5(2.5)	3.5(1.5)	2.5(0.5)
ø40	7	6	13	12	10	9	6.5	5.5	12	11	10.5	9.5	8.5	7.5

* Factors in parentheses are the setting positions for models with air cushion.

Mounting Height of Auto Switch

(mm)

D-B5 D-B6 D-B59W D-G5NTL D-H7C	D-C7 D-C8 D-H7□ D-H7□W D-H7BAL D-H7□F	D-C73C D-C80C	D-A3□A D-G39A D-K39A	D-A44A
Hs	Hs	Hs	Hs	Hs
25.5	22.5	25	60	69.5
28	25	27.5	62.5	72
31.5	28.5	31	66	75.5
35.5	32.5	35	70	79.5

- CL
- MLG
- CNA
- CNG
- MNB
- CNS
- CLS
- CB
- CV/MVG
- CXW
- CXS
- CXT
- MX
- MXU
- MXH
- MXS
- MXQ
- MXF
- MXW
- MXP
- MG
- MGP
- MGQ
- MGG
- MGC
- MGF
- MGZ
- CY
- MY

End Lock Cylinder

Series CBA1

ø40, ø50, ø63, ø80, ø100

How to Order

Standard

CBA1

L [] 50 150 [] H N

With auto switch

CDBA1

L [] 50 150 [] H N A53 []

Air cylinder with auto switch

Mounting

B	Basic
L	Axial foot
F	Front flange
G	Rear flange
C	Single clevis
D	Double clevis
T	Centre trunnion

Style

—	Lube
N	Non-lube
F	Steel tube

Bore size

40	40mm
50	50mm
63	63mm
80	80mm
100	100mm

Cylinder stroke (mm)
(Refer to the standard stroke table on p.3.8-13.)

Number of auto switches

—	2
S	1
n	n

Auto switch

—	Without auto switch
---	---------------------

* Refer to the table below for applicable auto switches.

Manual releasing style

N	Non-locking style
L	Locking style

Lock position

H	Rear end lock
R	Front end lock
W	Double end lock

Rod boot/Cushion

Rod boot	J	Nylon tarpaulin
	K	Neo plain cloth
Cushion	N	Without cushion
	R	With cushion on rod side
	H	With cushion on head side
—	—	With cushion on both sides

* When specifying symbol more than one, combine symbols in alphabetical order.

Applicable Auto Switches

Style	Special feature	Electrical entry	Indicator	Wiring (Output)	Load voltage		Model		Lead wire* (m)				Applicable load			
					DC	AC	Tie rod mounted	Band mounted	0.5 (—)	3 (L)	5 (Z)	(N)				
Reed switch	—	Grommet	Yes	3 wires (Equiv. to NPN)	—	5V	—	A56	—	●	●	—	—	IC	—	
						12V	—	A53	B53	●	●	●	—	—	PLC	
						12V	100V/200V	A54	B54	●	●	●	—	—	PLC	
						5V	—	A67	—	●	●	—	—	—	IC	
						12V	—	A64	B64	●	●	—	—	—	PLC	
						5V/12V	200V or less	A64	B64	●	●	—	—	—	PLC	
	—	Conduit terminal	DIN connector	Yes	2 wires	—	100V	—	A33C	A33	—	—	—	●	—	PLC
							200V	—	A34C	A34	—	—	—	●	—	PLC
							—	—	A44C	A44	—	—	—	●	—	PLC
							—	—	A59W	B59W	●	●	—	—	—	PLC
Solid state switch	—	Grommet	Yes	3 wires (NPN)	24V	5V	—	F59	G59	●	●	○	—	IC	—	
						12V	—	F5P	G5P	●	●	○	—	IC		
						—	100V/200V	J51	—	●	●	○	—	—		
						12V	—	J59	K59	●	●	○	—	—		
						5V	—	G39C	G39	—	—	—	●	—	IC	
						12V	—	K39C	K39	—	—	—	●	—	—	
	Diagnosis indication (2 colour)	Grommet	Yes	3 wires (NPN)	24V	5V	—	F59W	G59W**	●	●	○	—	IC	PLC	
						12V	—	F5PW	G5PW**	●	●	○	—	IC		
						5V	—	F59W	G59W**	●	●	○	—	IC		
						12V	—	F5PW	G5PW**	●	●	○	—	IC		
Water resist. (2 colour)	Grommet	Yes	2 wires	24V	12V	—	J59W	K59W**	●	●	○	—	—			
					—	—	F5BA	G5BA**	—	●	○	—	—			
With timer	Grommet	Yes	3 wires (NPN)	24V	5V	—	F5NT	G5NT	—	●	○	—	IC			
					12V	—	F59F	G59F**	●	●	○	—	IC			
Diagnosis output latch (2 colour)	Grommet	Yes	4 wires (NPN)	24V	—	—	F5LF	—	●	●	○	—	—			

* Symbols for reed wire length 0.5m... EX.)A53 5m...Z EX.)A53Z
3m...L EX.)A53LN EX.)A53N

* Solid state switches marked with "O" are manufactured upon receipt of order.

** D-G5□W, D-K59W, D-G5BAL and D-G59F can not be attached on ø40 and ø50 lubrication style cylinder.

Maintains the cylinder's original position even if the air supply is interrupted.

When air is discharged at the stroke end position, the lock engages to maintain the rod in that position.

Has the same dimensions as the standard cylinder (Series CA1). Non-locking style and locking style manual releases are standard.



Made to Order Specifications

Refer to p.5.4-1 for made to order specifications of series CBA1.

Specifications

Model	Lube, Non-lube
Fluid	Air
Proof pressure	1.5MPa
Max. operating pressure	1.0MPa
Min. operating pressure	0.15MPa*
Ambient and fluid temperature	Without auto switch: -10 to 70°C (No freezing) With auto switch: -10 to 60°C (No freezing)
Piston speed	50 to 500mm/s
Cushion	Equipped
Thread tolerance	JIS 2nd class
Stroke tolerance	up to 250 ST : $^{+1.0}_{-0}251$ to 1000 ST : $^{+1.4}_{-0}1001$ to 1500 ST :
Mounting	Basic, Axial foot, Front flange, Rear flange, Single clevis, Double clevis, Centre trunnion

* At 0.05MPa for other parts than lock part.

Lock Specifications

Lock positions	Front end, Rear end, Both ends				
Holding force (Max.) (N)	ø40	ø50	ø63	ø80	ø100
	860	1340	2140	3450	5390
Back lush	1mm or less				
Manual release	Non-locking style, Locking style				

Accessories/Refer to p.1.13-15 for further information.

Accessory	Standard			Option		
	Rod end nut	Clevis pin	Lock release belt (N type only)	Single knuckle joint	Double knuckle joint (with pins)	Rod bo
Mounting						
Basic	●	—	●	●	●	●
Axial foot	●	—	●	●	●	●
Front flange	●	—	●	●	●	●
Rear flange	●	—	●	●	●	●
Single clevis	●	—	●	●	●	●
Double clevis*	●	●	●	●	●	●
Centre trunnion	●	—	●	●	●	●

* Pins, cotter pins and flat washers are attached to double clevis type and double knuckle joint.

Standard Stroke

Bore (mm)	Standard stroke (mm)
40	25, 50, 75, 100, 125, 150, 175, 200, 250, 300, 350, 400, 450, 500
50, 63	25, 50, 75, 100, 125, 150, 175, 200, 250, 300, 350, 400, 450, 500, 600
80, 100	25, 50, 75, 100, 125, 150, 175, 200, 250, 300, 350, 400, 450, 500, 600, 700



* Minimum stroke of auto switch attached style is different. Refer to p.3.8-14.

Rod Boot Materials

Symbol	Materials	Max. ambient temp
J	Nylon tarpaulin	60°C
K	Neo plain cloth	110°C*

* Maximum ambient temperature for the rod boot its

Auto Switch Mounting Bracket Part No.

Model	Bore size (mm)				
	40	50	63	80	100
D-A5/A6 D-A59W D-F5□/J5□ D-F5□W/J59W D-F5NTL D-F5BAL/F59F	BT-04	BT-04	BT-06	BT-08	BT-08
D-A3/A44 D-G39/K39	BD1-04M	BD1-05M	BD1-06M	BD1-08M	BD1-10M

* Mounting brackets are attached to D-A3□C, D-A44C, D-G39C, D-K39C.

Order the auto switch depending on the cylinder size as follows:

Ex.) ø40-D-A3□C-4, ø63-D-A3□C-6, ø100-D-A3□C-10,

ø50-D-A3□C-5, ø80-D-A3□C-8

Model	Bore size (mm)				
	40	50	63	80	100
D-B5/B6 D-B59W D-G5□/K59 D-G5□W/J59W D-G5BAL D-G59F/G5NTL	BA-04	BA-05	BA-06	BA-08	BA-10
D-A3□C/A44C D-G39C/K39C	BA3-040	BA3-050	BA3-063	BA3-080	BA3-100

To order the mounting brackets separately, use the part number shown above.



*Stainless steel mounting bolt set

The set of stainless steel mounting screws (with set screw) described below is available and can be used depending on the operating environment. (The mounting bracket and band for auto switches must be ordered separately, as they are not included.)

BBA1: For D-A5, D-A6, D-F5 and D-J5

BBA3: For D-B5, D-B6, D-G5 and D-K5

The stainless steel bolts described above are used when the D-F5BAL/G5BAL type switch is shipped mounted on a cylinder. When the switches are shipped as individual parts, the BBA1 and BBA3 set are included.

CL
MLG
CNA
CNG
MNB
CNS
CLS
CB
CV/MVG
CXW
CXS
CXT
MX
MXU
MXH
MXS
MXQ
MXF
MXW
MXP
MG
MGP
MGQ
MGG
MGC
MGF
MGZ
CY
MY

Series CBA1

Minimum Strokes for Auto switch Mounting n: No. of auto switches (mm)

Model	No. of auto switches	Mounting brackets except centre trunnion	Centre trunnion style			
			ø40-ø50	ø63	ø80	ø100
D-A5, A6 D-F5□, J5□	2 (Dif. / same side(s)), 1	15	90	100	110	120
	n (Same side)	15+55 $\frac{(n-2)}{2}$ n=2, 4, 6, 8, ...	90+55 $\frac{(n-4)}{2}$ n=4, 8, 12, 16, ...	100+55 $\frac{(n-4)}{2}$ n=4, 8, 12, 16, ...	110+55 $\frac{(n-4)}{2}$ n=4, 8, 12, 16, ...	120+55 $\frac{(n-4)}{2}$ n=4, 8, 12, 16, ...
D-A59W	2 (Dif. / same side(s))	20	90	100	110	120
	n (Same side)	20+55 $\frac{(n-2)}{2}$ n=2, 4, 6, 8, ...	90+55 $\frac{(n-4)}{2}$ n=4, 8, 12, 16, ...	100+55 $\frac{(n-4)}{2}$ n=4, 8, 12, 16, ...	110+55 $\frac{(n-4)}{2}$ n=4, 8, 12, 16, ...	120+55 $\frac{(n-4)}{2}$ n=4, 8, 12, 16, ...
	1	15	90	100	110	120
D-F5□W, J59W D-F5BAL D-F59F D-F5NTL	2 (Dif. / same side(s)), 1	25	110	120	130	140
	n (Same side)	25+55 $\frac{(n-2)}{2}$ n=2, 4, 6, 8, ...	110+55 $\frac{(n-4)}{2}$ n=4, 8, 12, 16, ...	120+55 $\frac{(n-4)}{2}$ n=4, 8, 12, 16, ...	130+55 $\frac{(n-4)}{2}$ n=4, 8, 12, 16, ...	140+55 $\frac{(n-4)}{2}$ n=4, 8, 12, 16, ...
D-B5, B6 D-G5□, K59	2 Dif. sides	15	90	100	110	
	Same side	75	90	100	110	
D-G5□W K59W D-G5BAL D-G59F D-G5NTL	n	Dif. sides	15+50 $\frac{(n-2)}{2}$ n=2, 4, 6, 8, ...	90+50 $\frac{(n-4)}{2}$ n=4, 8, 12, 16, ...	100+50 $\frac{(n-4)}{2}$ n=4, 8, 12, 16, ...	110+50 $\frac{(n-4)}{2}$ n=4, 8, 12, 16, ...
		Same side	75+50(n-2) n=2, 3, 4, ...	90+50(n-2) n=2, 4, 6, 8, ...	100+50(n-2) n=2, 4, 6, 8, ...	110+50(n-2) n=2, 4, 6, 8, ...
	1	10	90	100	110	
D-B59W	2 Dif. sides	20	90	100	110	
	Same side	75	90	100	110	
	n	Dif. sides	20+50(n-2) n=2, 4, 6, 8, ...	90+50 $\frac{(n-4)}{2}$ n=4, 8, 12, 16, ...	100+50 $\frac{(n-4)}{2}$ n=4, 8, 12, 16, ...	110+50 $\frac{(n-4)}{2}$ n=4, 8, 12, 16, ...
Same side		75+50 $\frac{(n-2)}{2}$ n=2, 3, 4, ...	90+50(n-2) n=2, 4, 6, 8, ...	100+50(n-2) n=2, 4, 6, 8, ...	110+50(n-2) n=2, 4, 6, 8, ...	
1	15	90	100	110		
D-A3 D-G39 D-K39	2 Dif. sides	35	75	80	90	
	Same side	100	100	100	100	
	n	Dif. sides	35+30(n-2) n=2, 3, 4, ...	75+30(n-2) n=2, 4, 6, 8, ...	80+30(n-2) n=2, 4, 6, 8, ...	90+30(n-2) n=2, 4, 6, 8, ...
Same side		100+100(n-2) n=2, 3, 4, ...	100+100(n-2), n=2, 4, 6, 8, ...			
1	10	75	80	90		
D-A44	2 Dif. sides	35	75	80	90	
	Same side	55	75	80	90	
	n	Dif. sides	35+30(n-2) n=2, 3, 4, ...	75+30(n-2) n=2, 4, 6, 8, ...	80+30(n-2) n=2, 4, 6, 8, ...	90+30(n-2) n=2, 4, 6, 8, ...
Same side		55+50(n-2) n=2, 3, 4, ...	75+50(n-2) n=2, 4, 6, 8, ...	80+50(n-2) n=2, 4, 6, 8, ...	90+50(n-2) n=2, 4, 6, 8, ...	
1	10	75	80	90		
D-A3□C D-G39C D-K39C	2 Dif. sides	20	75	80	90	
	Same side	100	100	100	100	
	n	Dif. sides	20+35(n-2) n=2, 3, 4, ...	75+35(n-2) n=2, 4, 6, 8, ...	80+35(n-2) n=2, 4, 6, 8, ...	90+35(n-2) n=2, 4, 6, 8, ...
Same side		100+100(n-2) n=2, 3, 4, 5, ...	100+100(n-2), n=2, 4, 6, 8, ...			
1	10	75	80	90		
D-A44C	2 Dif. sides	20	75	80	90	
	Same side	55	75	80	90	
	n	Dif. sides	20+35(n-2) n=2, 3, 4, ...	75+35(n-2) n=2, 4, 6, 8, ...	80+35(n-2) n=2, 4, 6, 8, ...	90+35(n-2) n=2, 4, 6, 8, ...
Same side		55+50(n-2) n=2, 3, 4, ...	75+50(n-2) n=2, 4, 6, 8, ...	80+50(n-2) n=2, 4, 6, 8, ...	90+50(n-2) n=2, 4, 6, 8, ...	
1	10	75	80	90		

Weight/Aluminum Tube (Iron tube) (kg)

	Bore size (mm)	40	50	63	80	100
		Basic	0.89 (0.94)	1.36 (1.40)	2.00 (2.04)	3.48 (3.63)
Standard weight	Axial foot	1.08 (1.13)	1.58 (1.62)	2.34 (2.38)	4.15 (4.30)	5.86 (6.06)
	Flange	1.26 (1.30)	1.81 (1.86)	2.79 (2.84)	4.93 (5.08)	6.79 (6.99)
	Single clevis	1.12 (1.17)	1.70 (1.74)	2.63 (2.67)	4.59 (4.74)	6.65 (6.86)
	Double clevis	1.16 (1.21)	1.79 (1.84)	2.79 (2.83)	4.88 (5.03)	7.17 (7.38)
	Trunnion	1.25 (1.35)	1.84 (1.94)	2.80 (3.00)	5.03 (5.32)	7.15 (7.54)
Additional weight per 50 strokes	All mounting brackets (Except trunnion of iron tube)	0.22 (0.28)	0.28 (0.35)	0.37 (0.43)	0.52 (0.70)	0.65 (0.87)
	Trunnion style of iron tube	(0.36)	(0.46)	(0.65)	(0.86)	(1.07)
Accessory	Single knuckle joint	0.23	0.26	0.26	0.60	0.83
	Double knuckle joint (with pins)	0.37	0.43	0.43	0.87	1.27

* Factors in parentheses are for iron tube style.

Additional Weight of Lock (kg)

	Bore size (mm)	40	50	63	80	100	
		Manual release non-locking style (N)	Rear end lock (H)	0.02	0.03	0.03	0.10
Manual release locking style (L)	Rear end lock (R)	Front end lock(R)	0.02	0.02	0.02	0.07	0.06
		Double end lock (W)	0.04	0.05	0.05	0.17	0.18
		Front end lock (H)	0.04	0.05	0.05	0.13	0.15
Manual release locking style (L)	Double end lock (W)	Front end lock (R)	0.04	0.04	0.04	0.10	0.09
		Double end lock (W)	0.08	0.09	0.09	0.23	0.24

Calculation example: **CBA1L40-100-HN**

- Basic weight.....1.08kg(ø40 foot style)
 - Lock weight.....0.02 (Rear end lock, Non-locking)
 - Additional weight.....0.22/50 stroke
 - Cylinder stroke.....100 stroke
- 1.08+0.22 X 100/50+0.02=1.54kg

⚠ Precautions

Be sure to read before handling.
Refer to p.0-39 to 0-46 for Safety Instructions and common precautions, and refer to p.3.8-2 for precautions on series CB.

Replacement

⚠ Caution

- ① Socket wrench should be used when mounting brackets are replaced. Refer to the table below for sockets.

Bore size (mm)	Nut	Width across flats	Socket
40/50	JIS B1181 3rd class intermediateM8	13	JIS B4636 + Two-angle socket13
63	JIS B1181 3rd class intermediateM10 X 1.25	17	JIS B4636 + Two-angle socket17
80/100	JIS B1181 3rd class intermediateM12 X 1.75	19	JIS B4636 + Two-angle socket19

Construction

Lube style

With rear end lock

Manual release locking style

: Suffix L

Manual release non-locking style: Suffix N

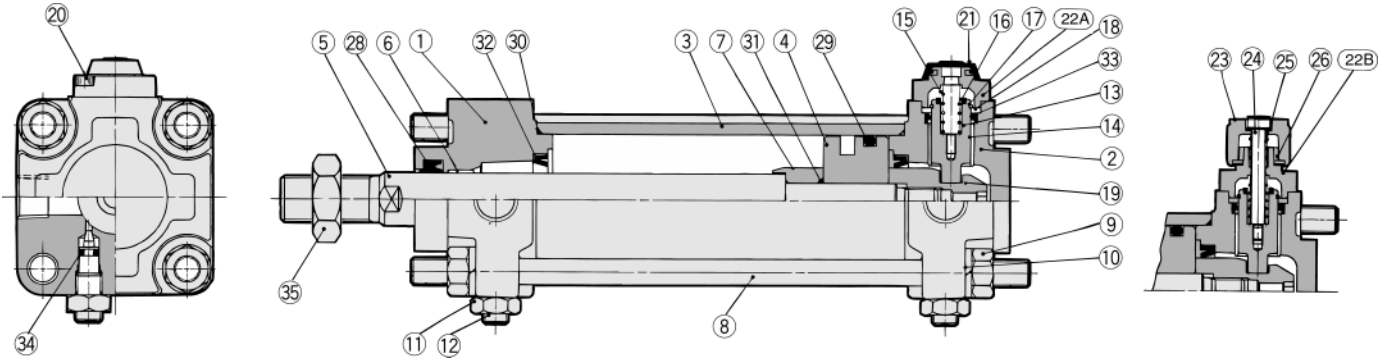

With front end lock

Non-lube style

Lube style long stroke

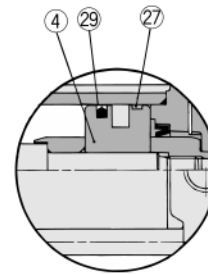
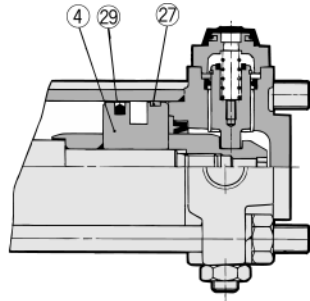
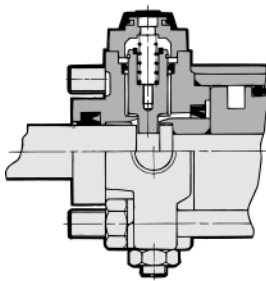

Component Parts

No.	Description	Material	Piece	Notes
①	Rod cover	Aluminum alloy	1	Black painting
②	Head cover	Aluminum alloy	1	Black painting
③	Cylinder tube*	Aluminum alloy	1	Hard anodized
④	Piston	Aluminum alloy	1	Chromate
⑤	Piston rod	Carbon steel	1	Hard chrome plated
⑥	Bush	Zinc bronze die cast	1	
⑦	Cushion ring	Rolled steel	1	Zinc chromated
⑧	Tie rod	Carbon steel	4	Chromated
⑨	Tie rod nut	Rolled steel	8	Black zinc chromate
⑩	Spring washer	Steel wire	8	Black zinc chromate
⑪	Lock nut	Rolled steel	2	Nickel plated
⑫	Cushion valve	Rolled steel	2	Electroless nickel plated
⑬	Lock piston	Carbon steel	1	Quenching, Hard chrome plated
⑭	Lock bushing	Zinc bronze die cast	1	
⑮	Lock spring	Steel wire	1	Zinc chromated
⑯	Bumper	Urethane	1	
⑰	C ring	Steel wire	1	Zinc chromated
⑱	Packing retainer	Rolled steel	1	Zinc chromated
⑲	Cushion ring nut	Alloy steel	1	Quenching, Electroless nickel plated
⑳	Hexagon socket head cap screw	Alloy steel	2	Black zinc chromated
㉑	Rubber cap	Synthetic rubber	1	
㉒A	Cap A	Aluminum die cast	1	Black painting
㉒B	Cap B	Carbon steel	1	Tuffride
㉓	M/O knob	Zinc die cast	1	Black painting
㉔	M/O bolt	Alloy steel	1	Black zinc chromated
㉕	M/O spring	Steel wire	1	Zinc chromated
㉖	Stopper ring	Carbon steel	1	Zinc chromated
㉗	Wear ring	Resin	1	
㉘	Rod end nut	Rolled steel	1	Nickel plated

* ③. Cylinder tube: For steel tube, carbon steel tube (hard chromium plating inside) is used.

Component Parts

No.	Description	Material	Notes
㉘	Rod seal	NBR	
㉙	Piston seal	NBR	
㉚	Cylinder tube gasket	NBR	
㉛	Piston gasket	NBR	
㉜	Cushion seal	NBR	
㉝	Lock piston seal	NBR	
㉞	Cushion valve seal	NBR	

Replacement Parts: Seal Kits

Bore size (mm)	Kit No.				
	40	50	63	80	100
Lube with single end lock	CBA1-40A-PS	CBA1-50A-PS	CBA1-63A-PS	CBA1-80A-PS	CBA1-100A-PS
Non-lube with single end lock	CBA1N40A-PS	CBA1N50A-PS	CBA1N63A-PS	CBA1N80A-PS	CBA1N100A-PS
Lube with double end lock	CBA1-40A-PS-W	CBA1-50A-PS-W	CBA1-63A-PS-W	CBA1-80A-PS-W	CBA1-100A-PS-W
Non-lube with double end lock	CBA1N40A-PS-W	CBA1N50A-PS-W	CBA1N63A-PS-W	CBA1N80A-PS-W	CBA1N100A-PS-W

* ㉘, ㉙, ㉚, ㉛, ㉜, ㉝, ㉞ are packed together as one set of packings. Order with the order numbers for respective tube bore size. (㉜ cannot be replaced.)

- CL
- MLG
- CNA
- CNG
- MNB
- CNS
- CLS
- CB
- CV/MVG
- CXW
- CXS
- CXT
- MX
- MXU
- MXH
- MXS
- MXQ
- MXF
- MXW
- MXP
- MG
- MGP
- MGQ
- MGG
- MGC
- MGF
- MGZ
- CY
- MY

Series CBA1

Basic (The dimensions are common regardless of the lock positions.)

With rear end lock: CBA1B -HN

Manual release locking
: Suffix L

Manual release non-locking
: Suffix N

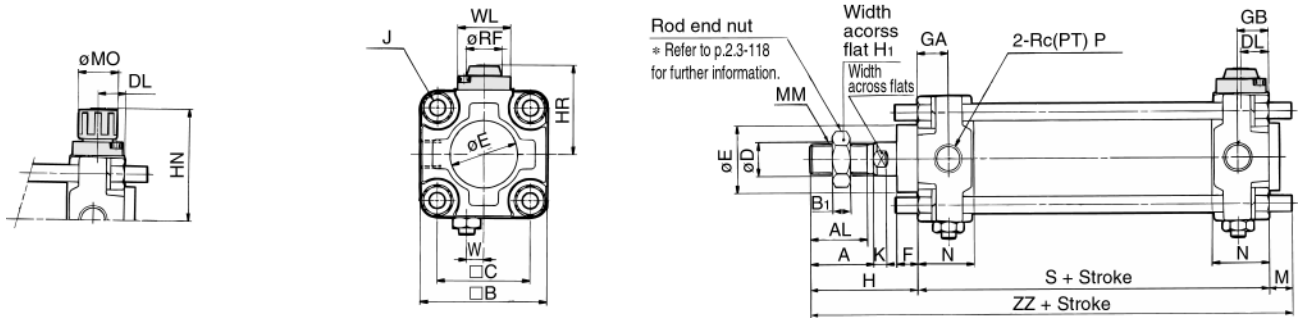

With front end lock: CBA1B -RN

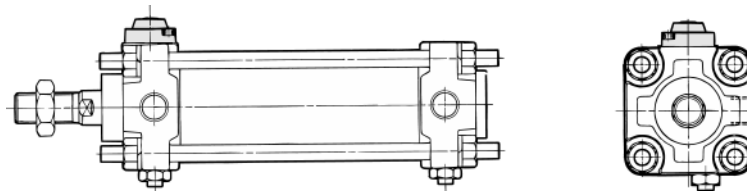

With double end lock: CBA1B -WN

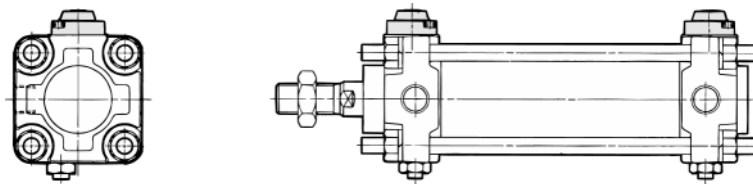

With rod boot

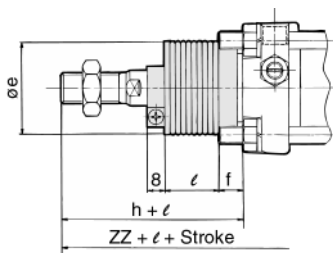

Symbol	Stroke range	Width across flats	A	AL	B	B ₁	C	D	DL	E	F	GA	GB	H	H ₁	HR	HN (MAX)	J	K	M	MM	MO	N	P	RF	S	W	WL	ZZ
40	up to 500	14	30	27	60	8	44	16	13	32	10	15	15	51	22	42.3	56	M8	6	11	M14 X 1.5	19	27	1/4	17	84	8	25	146
50	up to 600	18	35	32	70	11	52	20	13	40	12	17	17	58	27	47.3	61	M8	7	11	M18 X 1.5	19	30	3/8	17	90	0	25	159
63	up to 600	18	35	32	85	11	64	20	15.5	40	10	17	17	58	27	54.8	68.5	M10 X 1.25	7	14	M18 X 1.5	19	31	3/8	17	98	0	25	170
80	up to 750	22	40	37	102	13	78	25	18.5	52	14	21	21	71	32	65.8	80.5	M12 X 1.75	11	17	M22 X 1.5	23	37	1/2	21	116	0	40	204
100	up to 750	26	40	37	116	16	92	30	20	52	14	21	21	72	41	72.8	87.5	M12 X 1.75	11	17	M26 X 1.5	23	40	1/2	21	126	0	40	215

* Refer to p.3.8-18 for further information on rod end nuts and accessories.

With rod boot

Bore (mm)	Stroke range (mm)	øe	f	h	l	ZZ
40	20 to 500	43	11.2	59	1/4 stroke	154
50	20 to 600	52	11.2	66	1/4 stroke	167
63	20 to 600	52	11.2	66	1/4 stroke	178
80	20 to 750	65	12.5	80	1/4 stroke	213
100	20 to 750	65	14	81	1/4 stroke	224

Dimensions: With Mounting Bracket

Axial foot: **CBA1L** Bore size Stroke $\begin{matrix} H \\ -R \\ W \\ L \\ N \end{matrix}$

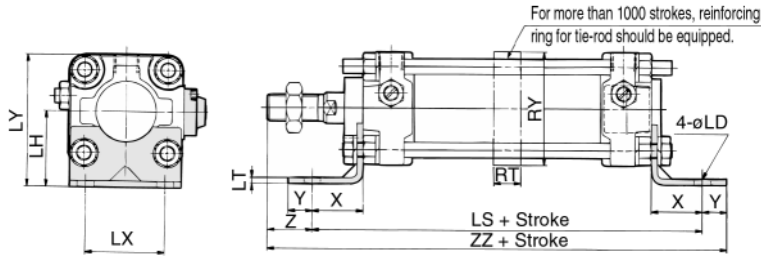

Front flange: **CBA1F** Bore size Stroke $\begin{matrix} H \\ -R \\ W \\ L \\ N \end{matrix}$

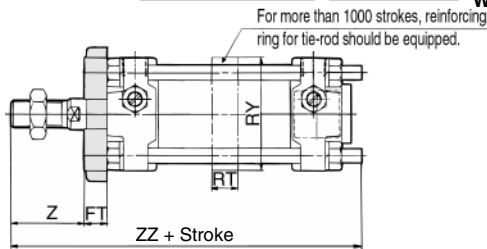

Front flange: **CBA1F** Bore size Stroke $\begin{matrix} H \\ -R \\ W \\ L \\ N \end{matrix}$

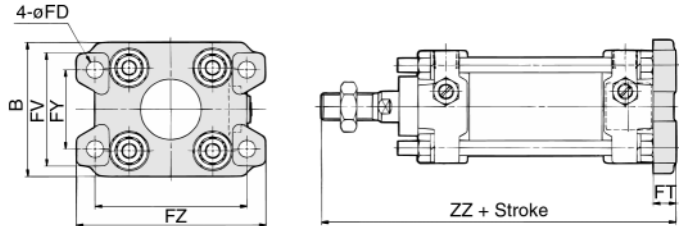

Single clevis: **CBA1C** Bore size Stroke $\begin{matrix} H \\ -R \\ W \\ L \\ N \end{matrix}$

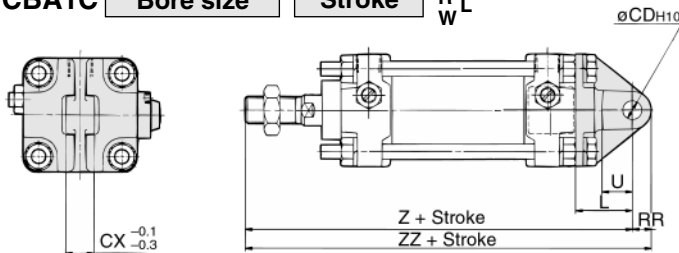

Refer to p.3.8-19 for dimensions of rotation receiving bracket.

Double clevis: **CBA1D** Bore size Stroke $\begin{matrix} H \\ -R \\ W \\ L \\ N \end{matrix}$

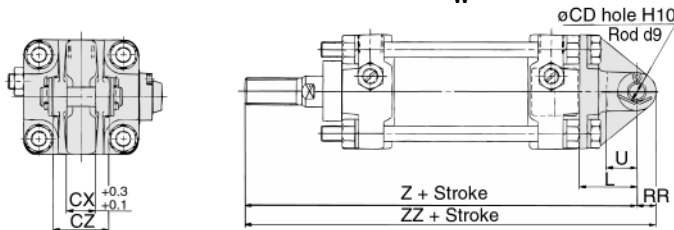

* Clevis pins, flat washers and split cotter pins are attached.

Centre trunnion: **CBA1T** Bore size Stroke $\begin{matrix} H \\ -R \\ W \\ L \\ N \end{matrix}$

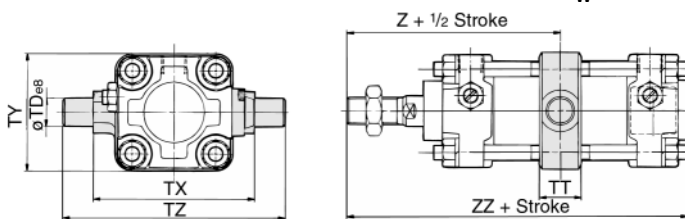

Symbol	Foot													Flange										Clevis										Center trunnion										(mm)
	Stroke range	LD	LH	LS	LT	LX	LY	RT	RY	X	Y	Z	ZZ	Stroke range Front	Stroke range Rear	B	FD	FT	FV	FX	FY	FZ	RT	RY	Z	ZZ Front	ZZ Rear	Stroke range	CD	CX	CZ	L	RR	U	Z	ZZ	Stroke range	TD	TT	TX	TY	TZ	Z	
40	≤800	9.0	40	138	3.2	42	70	—	—	27	13	24	175	≤800	≤500	71	9.0	12	60	80	42	100	—	—	39	146	147	≤500	10	15	29.5	30	10	16	165	175	≤500	15 ^{+0.032} _{-0.029}	22	85	62	117	93	140
50	≤1200	9.0	45	144	3.2	50	80	30	76	27	13	31	188	≤1000 (1001 to 1200)	≤600	81 (88)	9.0	12 (20)	70 (120)	50 (58)	110 (144)	30	76	46 (47)	159 (163)	160	≤600	12	18	38	35	12	19	183	195	≤600	15 ^{+0.032} _{-0.029}	22	95	74	127	103	154	
63	≤1200	11.5	50	166	3.2	59	93	40	92	34	16	24	206	≤1000 (1001 to 1200)	≤600	101 (105)	11.5 (23)	15 (23)	86 (140)	105 (64)	59 (170)	130 (170)	40	92	43 (48)	170 (179)	171	≤600	16	25	49	40	16	23	196	212	≤600	18 ^{+0.032} _{-0.029}	28	110	90	148	107	162
80	≤1400	13.5	65	204	4.5	76	116	45	112	44	16	27	247	≤1000 (1001 to 1400)	≤750	119 (124)	13.5 (28)	18 (28)	102 (164)	130 (84)	76 (160)	160 (198)	45	112	53 (59)	204 (215)	205	≤750	20	31.5	61	48	20	28	235	255	≤750	25 ^{+0.040} _{-0.033}	34	140	110	192	129	194
100	≤1500	13.5	75	212	6.0	92	133	50	136	43	17	29	258	≤1000 (1001 to 1500)	≤750	133 (140)	13.5 (29)	18 (29)	116 (180)	150 (100)	92 (180)	180 (220)	50	136	54 (60)	215 (227)	216	≤750	25	35.5	64	58	25	36	256	281	≤750	25 ^{+0.040} _{-0.033}	40	162	130	214	135	206

The factors in parentheses are for long stroke style.

- CL
- MLG
- CNA
- CNG
- MNB
- CNS
- CLS
- CB**
- CV/MVG
- CXW
- CXS
- CXT
- MX
- MXU
- MXH
- MXS
- MXQ
- MXF
- MXW
- MXP
- MG
- MGP
- MGQ
- MGG
- MGC
- MGF
- MGZ
- CY
- MY

End Lock Cylinder

Series CB

Accessory Dimensions

Y Type Double Knuckle Joint

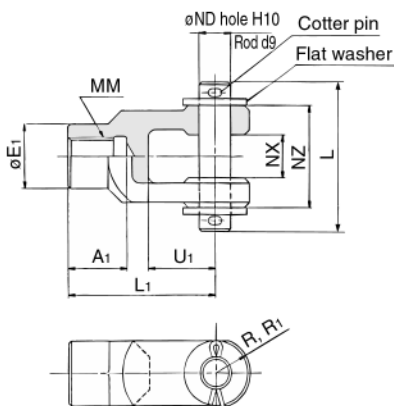

Material: Iron die cast

(mm)

Part No.	Bore size (mm)	A ₁	E ₁	L ₁	MM	RR ₁	U ₁	ND	NX	NZ	L	Cotter pin	Flat washer
Y-04C	40	22	24	55	M14 X 1.5	13	25	12	16 ^{+0.3} _{-0.1}	38	55.5	ø3 X 18ℓ	Polishing ball 12
Y-05C	50, 63	27	28	60	M18 X 1.5	15	27	12	16 ^{+0.3} _{-0.1}	38	55.5	ø3 X 18ℓ	Polishing ball 12
Y-08C	80	37	36	71	M22 X 1.5	19	28	18	28 ^{+0.3} _{-0.1}	55	76.5	ø4 X 25ℓ	Polishing ball 18
Y-10C	100	37	40	83	M26 X 1.5	21	38	20	30 ^{+0.3} _{-0.1}	61	83	ø4 X 30ℓ	Polishing ball 20

* Knuckle pins, cotter pins and flat washer are attached.

Clevis Pin/Knuckle Pin

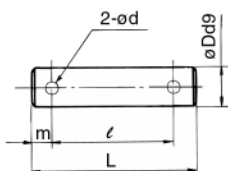

Material: Carbon steel

(mm)

Part No.	Bore size (mm)		Dd9	L	ℓ	m	d Drill through	Cotter pin	Flat washer
	Clevis	Knuckle							
CDP-2A	40	—	10 ^{-0.040} _{-0.076}	46	38	4	3	ø3 X 18ℓ	Polishing ball 10
CDP-3A	50	40, 50, 63	12 ^{-0.050} _{-0.093}	55.5	47.5	4	3	ø3 X 18ℓ	Polishing ball 12
CDP-4A	63	—	16 ^{-0.050} _{-0.093}	71	61	5	4	ø4 X 25ℓ	Polishing ball 16
CDP-5A	—	80	18 ^{-0.050} _{-0.093}	76.5	66.5	5	4	ø4 X 25ℓ	Polishing ball 18
CDP-6A	80	100	20 ^{-0.065} _{-0.117}	83	73	5	4	ø4 X 30ℓ	Polishing ball 20
CDP-7A	100	—	25 ^{-0.065} _{-0.117}	88	78	5	4	ø4 X 36ℓ	Polishing ball 24

I Type Single Knuckle Joint

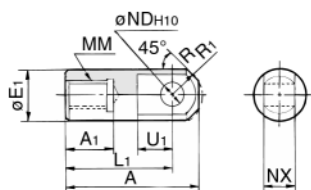

Rod End Nut (Standard accessory)

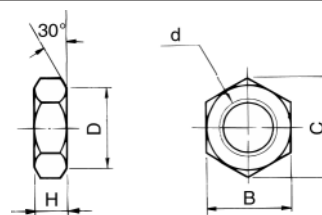

Material: Free cutting sulphur

(mm)

Part No.	Bore size (mm)	A	A ₁	E ₁	L ₁	MM	R ₁	U ₁	ND ^{H10}	NX
I-04	40	69	22	24	55	M14 X 1.5	15.5	20	12 ^{+0.070} ₀	16 ^{-0.1} _{0-0.3}
I-05	50, 63	74	27	28	60	M18 X 1.5	15.5	20	12 ^{+0.070} ₀	16 ^{-0.1} _{0-0.3}
I-08	80	91	37	36	71	M22 X 1.5	22.5	26	18 ^{+0.070} ₀	28 ^{-0.1} _{0-0.3}
I-10	100	105	37	40	83	M26 X 1.5	24.5	28	20 ^{+0.084} ₀	30 ^{-0.1} _{0-0.3}

Material: Rolled steel

(mm)

Part No.	Bore size (mm)	d	H	B	C	D
NT-04	40	M14 X 1.5	8	22	25.4	21
NT-05	50, 63	M18 X 1.5	11	27	31.2	26
NT-08	80	M22 X 1.5	13	32	37.0	31
NT-10	100	M26 X 1.5	16	41	47.3	39

Pivot Bracket for Trunnion

Material: Iron die cast
Surface treatment/Painted black

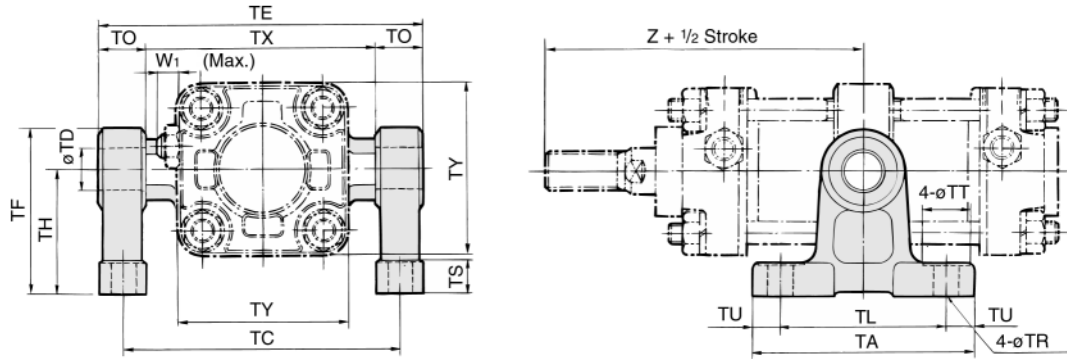

Note) The dimensions above are for reference. Brackets for trunnion should be ordered separately. (mm)

Part No.	Bore size (mm)	TA	TL	TU	TC	TX	TE	TO	TR	TT	TS	TH	TF	TY	W ₁	Z	TD-H10 (Hole)
CA1-S04	40	80	60	10	102	85	119	17	9	17	12	45	60	62	10	93	15 ^{+0.070} ₀
	50	80	60	10	112	95	129	17	9	17	12	45	60	74	10	103	15 ^{+0.070} ₀
CA1-S06	63	100	70	15	130	110	150	20	11	22	14	55	73	90	10	107	18 ^{+0.070} ₀
CA1-S08	80	120	90	15	166	140	192	26	13.5	24	17	75	100	110	12	129	25 ^{+0.084} ₀
	100	120	90	15	188	162	214	26	13.5	24	17	75	100	130	12	135	25 ^{+0.084} ₀

Pivot Bracket for Double Clevis

Material/Iron die cast
Surface treatment/Painted black

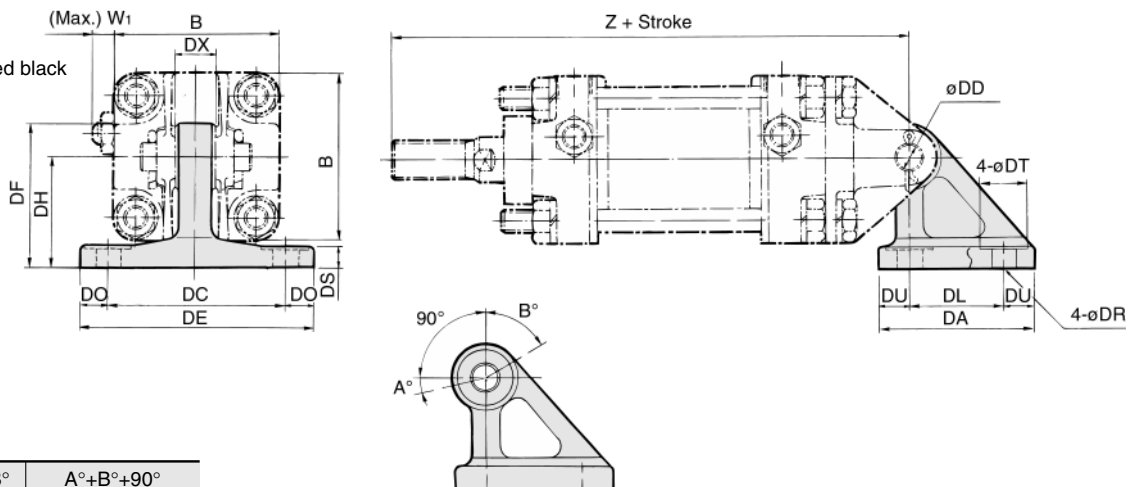

Rotation Angle

Bore size (mm)	A°	B°	A°+B°+90°
40° to 100°	12°	60°	162°

Note) The dimensions above are for reference. Pivot brackets for double clevis should be ordered separately. (mm)

Part No.	Bore size (mm)	DA	DL	DU	DC	DX	DE	DO	DR	DT	DS	DH	DF	B	W ₁	Z	DDH10 (Hole)
CA1-B04	40	57	35	11	65	15	85	10	9	17	8	40	52	60	10	165	10 ^{+0.058} ₀
CA1-B05	50	57	35	11	65	18	85	10	9	17	8	40	52	70	10	183	12 ^{+0.070} ₀
CA1-B06	63	67	40	13.5	80	25	105	12.5	11	22	10	50	66	85	10	196	16 ^{+0.070} ₀
CA1-B08	80	93	60	16.5	100	31.5	130	15	13.5	24	12	65	90	102	12	235	20 ^{+0.084} ₀
CA1-B10	100	93	60	16.5	100	35.5	130	15	13.5	24	12	65	90	116	12	256	25 ^{+0.084} ₀

- CL
- MLG
- CNA
- CNG
- MNB
- CNS
- CLS
- CB
- CV/MVG
- CXW
- CXS
- CXT
- MX
- MXU
- MXH
- MXS
- MXQ
- MXF
- MXW
- MXP
- MG
- MGP
- MGQ
- MGG
- MGC
- MGF
- MGZ
- CY
- MY

Series CDBA1

Auto Switch Mounting Position and Mounting Height / The dimensions below are of lock released. Setting positions of auto switches are as follows.

<Band mounting style>

D-B5/B6/B59W

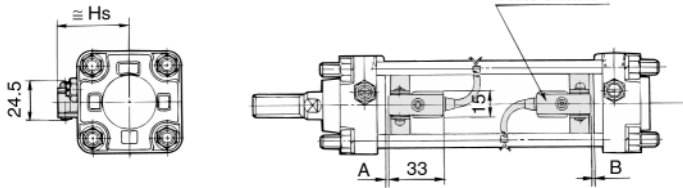

D-A3 D-G39/K39

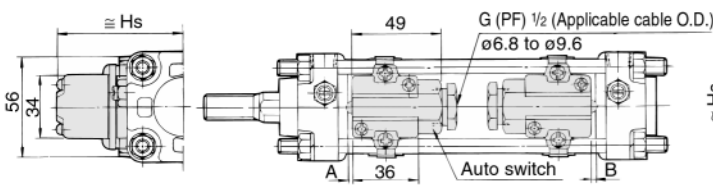

D-G5□/K59 D-G5□W/K59W D-G5BAL D-G59F/G5NTL

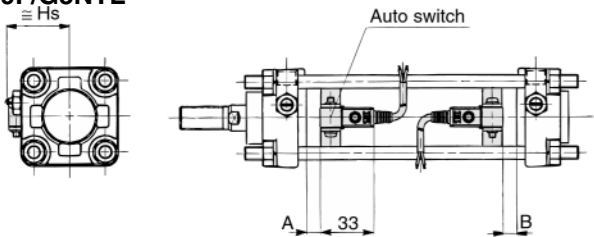

D-A44

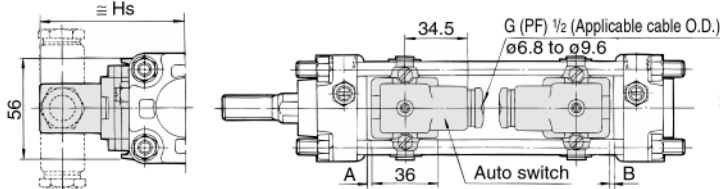

<Tie-rod mounting style>

D-A5/A6 D-A59W

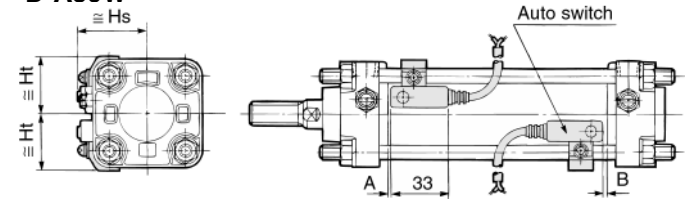

D-A3□C D-G39C/K39C

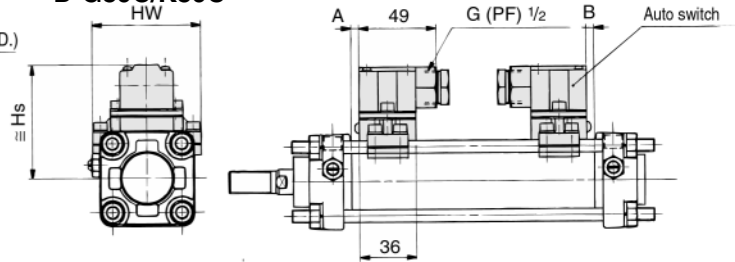

D-F5□/J59 D-F5NTL D-F5□W/J59W D-F5BAL/F5□F

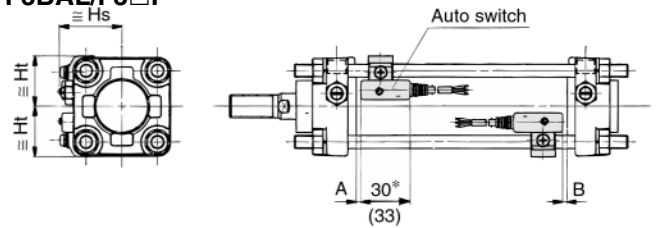

* The factors in parentheses are for D-F5LF.

D-A44C

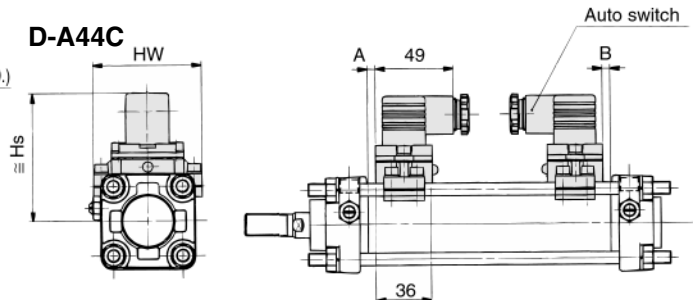

Setting Position of Auto Switch (mm)

Model	D-A5,A6		D-B5,B6		D-G5□		D-G5□W		D-G5NTL		D-F5□W		D-F5NTL	
	D-A3,A3□C		D-G5□W		D-K59		D-G5BAL		D-A59W		D-J59W		D-F5BAL	
	D-A44,A44C		D-K59W		D-B59W		D-G5NTL		D-F5□		D-F59W		D-F5NTL	
Bore size (mm)	A	B	A	B	A	B	A	B	A	B	A	B	A	B
	ø40	0	1	0	1.5	0.5	4.5	0	3	1	5	7.5	11.5	8.5
	(0)	(0)	(0.5)	(0)	(3.5)	(1.5)	(2)	(0)	(4)	(2)	(10.5)	(8.5)	(11.5)	(9.5)
ø50	0	1	0	1.5	0.5	4.5	0	3	1	5	7.5	11.5	8.5	12.5
	(0)	(0)	(0.5)	(0)	(3.5)	(1.5)	(2)	(0)	(4)	(2)	(10.5)	(8.5)	(11.5)	(9.5)
ø63	0	5.5	0	6	2.5	9	1	7.5	3	9.5	9.5	16	10.5	17
	(2.5)	(1.5)	(3)	(2)	(6)	(5)	(4.5)	(3.5)	(6.5)	(5.5)	(13)	(12)	(14)	(13)
ø80	2	8.5	2.5	9	5.5	12	4	10.5	6	12.5	12.5	19	13.5	20
	(6)	(4)	(6.5)	(4.5)	(9.5)	(7.5)	(8)	(6)	(10)	(8)	(16.5)	(14.5)	(17.5)	(15.5)
ø100	4	10.5	4.5	11	7.5	14	6	12.5	8	14.5	14.5	21	15.5	22
	(7.5)	(6.5)	(8)	(7)	(11)	(10)	(9.5)	(8.5)	(11.5)	(10.5)	(18)	(17)	(19)	(18)

* The factors in parentheses are for long stroke and non lubrication style. Long stroke is available in case of foot style and front flange style.

Mounting Height of Auto Switch (mm)

Model	D-B5, B6 D-B59W D-G5□ D-K59 D-G5NTL D-G5□W D-K59W D-G5BAL D-G59F		D-A3 D-G39 D-K39		D-A44		D-A5 D-A6 D-A59W		D-F5□ D-J5□ D-F5□W D-J59W D-F5BAL D-F59F D-F5NTL		D-A3□C D-G39C D-K39C		D-A44C	
	Hs	Hs	Hs	Hs	Hs	Ht	Hs	Ht	Hs	Hw	Hs	Hw	Hs	Hw
ø40	38	72.5	80.5	40	31	38.5	31	73	69	81	69			
ø50	43.5	78	86	43.5	35	42.5	35	78.5	77	86.5	77			
ø63	50.5	85	93	49	42	48	42	85.5	91	93.5	91			
ø80	59	93.5	101.5	55.5	50	54	50	94	107	102	107			
ø100	69.5	104	112	63	57.5	62	57.5	104	121	112	121			