

For material handling and clamping of small workpieces

Power Clamp Cylinder Compact Type

∅25, ∅32 ^{New}

- Lightweight
- Compact
- High clamping force
- Lock function

Lightweight Weight : **580 g** (∅25)

Compact Width : **34 mm**
Height : **192.4 mm**
(∅25, Arm opening angle: 90°)

Clamping force : **22.5 lbf [100 N]**
(∅32, Arm length: 50 mm, 73 psi [0.5 MPa] pressure)

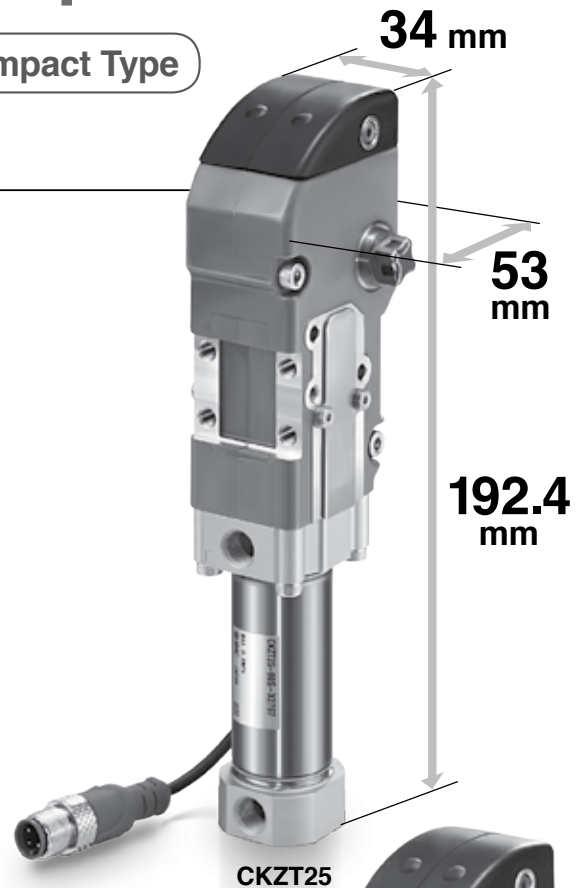

Force amplification with a toggle mechanism and lock function

Can hold a clamped state when supply pressure drops or residual pressure is released

Spatter-proof construction

Fully closed structure prevents the intrusion of spatter

Equipped with a proximity switch that can be used in welding magnetic fields

A model with a manually operated handle is available.

For manual workpiece setting processes

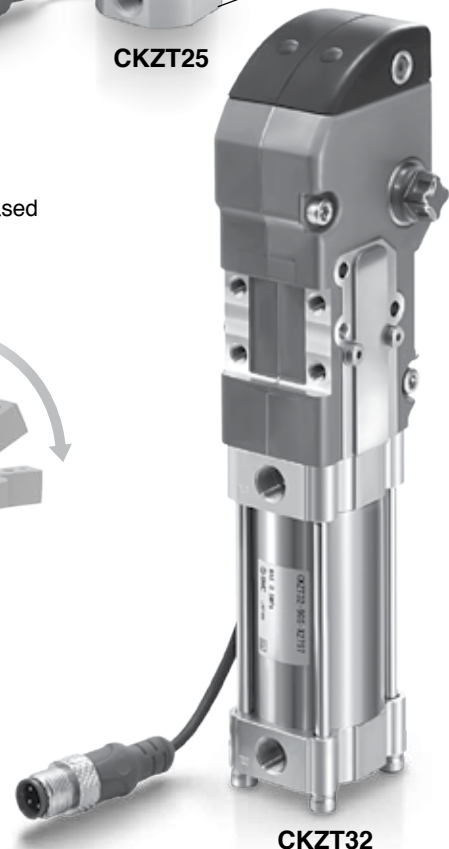
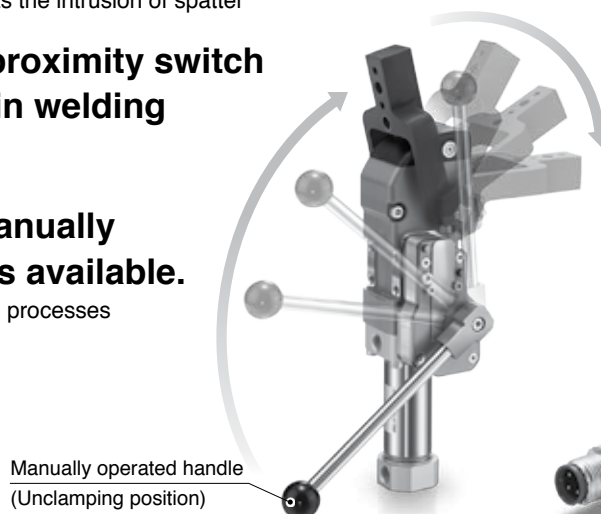

CKZT -X2797 (Base Type)
 -X2798 (With Manually Operated Handle)



Power Clamp Cylinder Compact Type

CKZT -X2797

CKZT -X2798 □

∅25, ∅32

How to Order

Base type

CKZT 25 - 105 S - X2797

With manually operated handle

CKZT 25 - 105 S - X2798 L

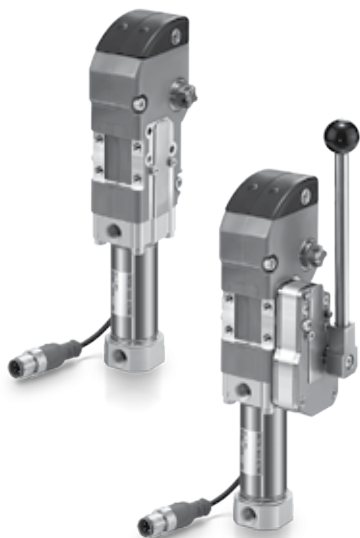

With manually operated handle

Bore size

25	25 mm
32	32 mm

Arm opening angle

90	90°
105	105°

* Please contact SMC for other opening angles.

Manually operated handle mounting position

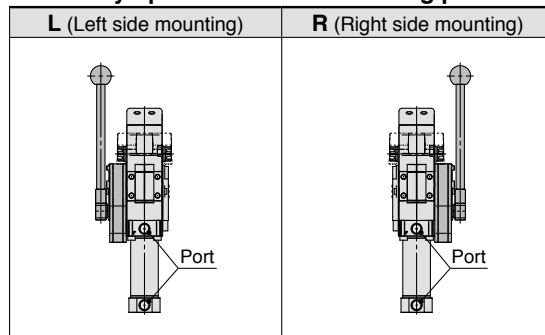

Clamp arm

CKZT 25 - A000 C S - X2797



Mounted clamp arm

Arm mounting position

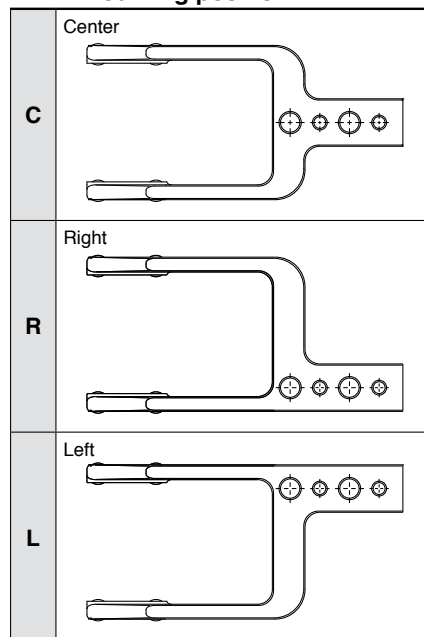

Cylinder Specifications

Bore size	25	32
Action	Double acting	
Fluid	Air	
Proof pressure	174 psi [1.2 MPa]	
Max. operating pressure	116 psi [0.8 MPa]	73 psi [0.5 MPa]
Min. operating pressure	44 psi [0.3 MPa]	
Ambient and fluid temperatures	14 to 140°F [-10 to 60°C] (No freezing)	
Cushion	Clamping side: None Unclamping side: Rubber bumper	
Operating time	Clamping: 1 sec. or more, Unclamping: 1 sec. or more	
Max. allowable clamping moment*1	55 lbf-ft [75 N·m]	

*1 Refers to the maximum holding force (torque) while clamped with the operating air exhausted. This is not the possible holding force (torque) for normal use.

Weight

Bore size	Base type cylinder	Cylinder with manually operated handle	Clamp arm
25	580	820	230
32	710	950	230

[g]

* The weight is the same for both arm opening angles of 90° and 105°.

Cylinder Stroke

Bore size	Arm opening angle	
	90°	105°
25, 32	35.4	39.5

[mm]

Proximity Switch Specifications

Part number	CKZ25-36-133NN-R
Manufacturer	SENSTRONIC
Power supply voltage	10 to 30 VDC
Output	N.O., PNP
Continuous load current	100 mA
Enclosure	IP67
Housing material	Aluminum alloy
Output indication	Clamping side: Red Unclamping side: Yellow
Voltage indication	Green
Connection cable length (M12 connector)	100 mm
Tightening torque for proximity switch mounting bolt	0.46 to 0.60 lbf-ft [0.63 to 0.82 N·m]

* Switch specifications correspond to the manufacturer's technical information.

Wiring Diagram (PNP Connection Circuit)

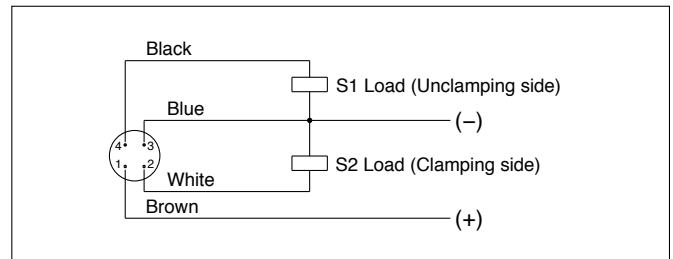

* Please contact SMC for NPN specifications.

Replacement Parts

Top cover kit no.

CKZ25-53B781EL-R

* The top cover kit includes a top cover and mounting brackets.

Replacement procedure

⚠ **Caution** Be sure to confirm safety and perform installation while the air is exhausted.

1) Mount the top cover to the clamp cylinder, then tighten to the specified tightening torque below.

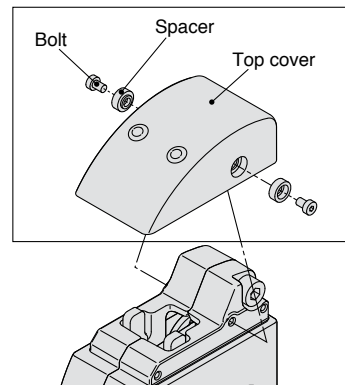

Top Cover Mounting Bolt Tightening Torque

Bore size	Tightening torque
25, 32	0.46 to 0.60 lbf-ft [0.63 to 0.82 N·m]

Dimensions

CKZT □-□S-X2797

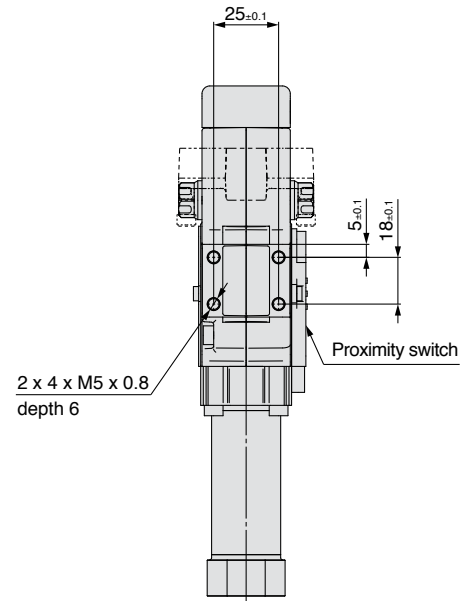
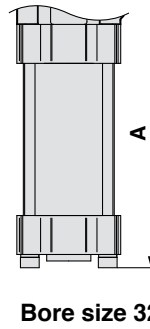
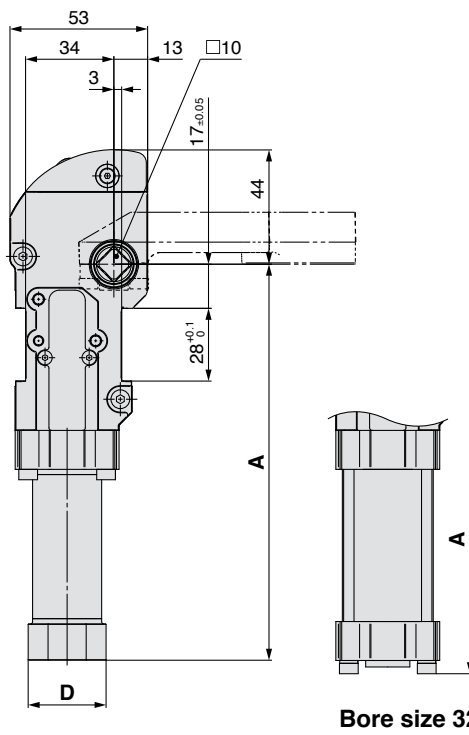
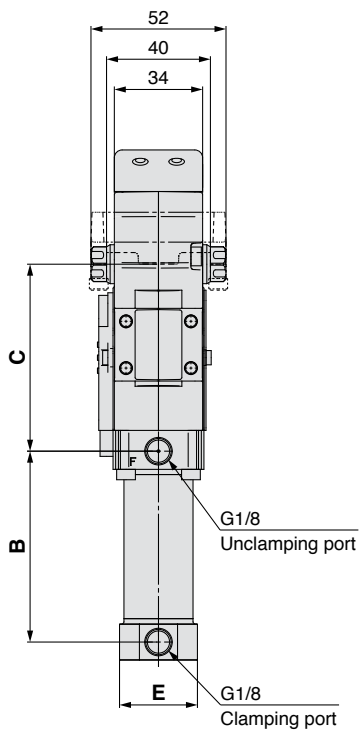
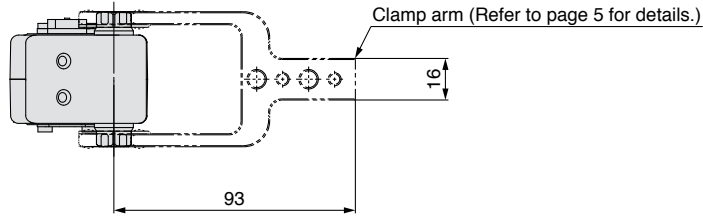

[mm]						
Bore size	Arm opening angle	A	B	C	D	E
25	90°	148.4	69.4	72	30	30
	105°	152.5	73.5			
32	90°	157.7	73.6	71.5	40	35
	105°					

Dimensions: With Manually Operated Handle

CKZT□-□S-X2798^R

* Refer to the CKZT□-□S-X2797 (page 3) for dimensions other than those shown below.

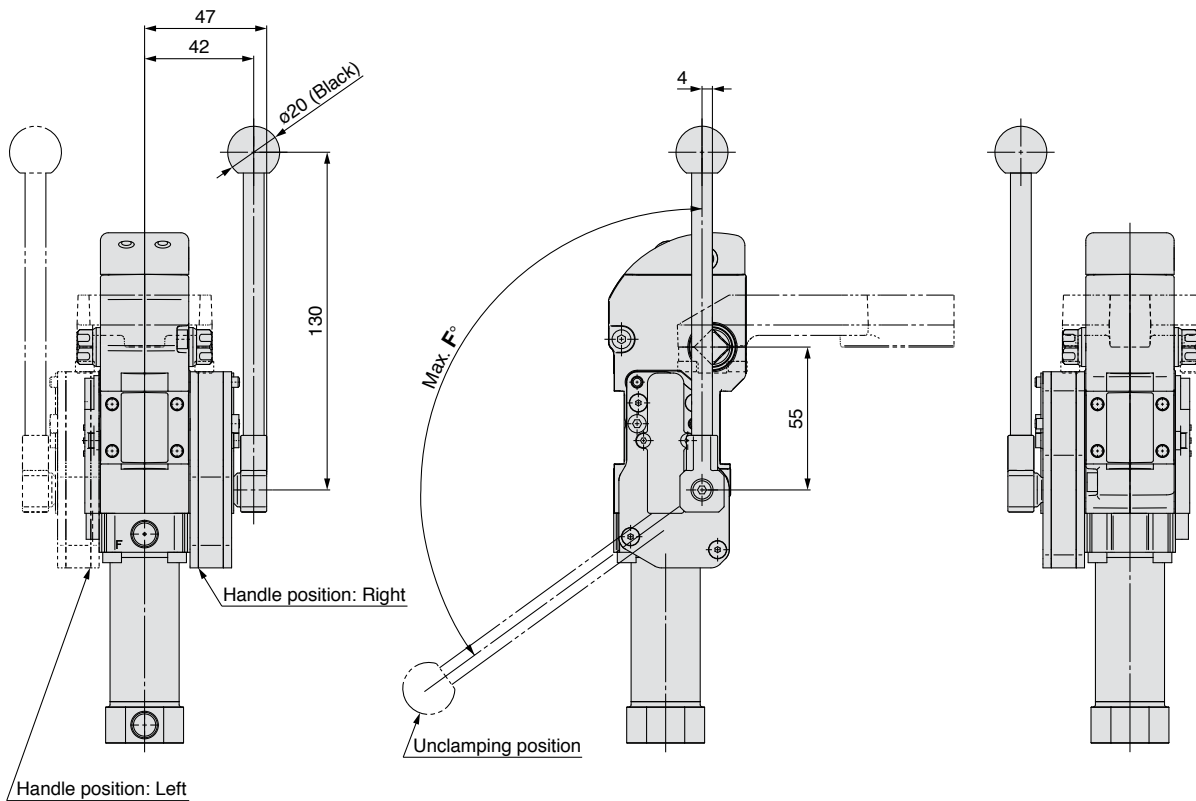

Bore size	Arm opening angle	F°
25	90°	110
	105°	126
32	90°	110
	105°	126

Dimensions: Clamp Arm

CKZT25-A000^C_LS-X2797

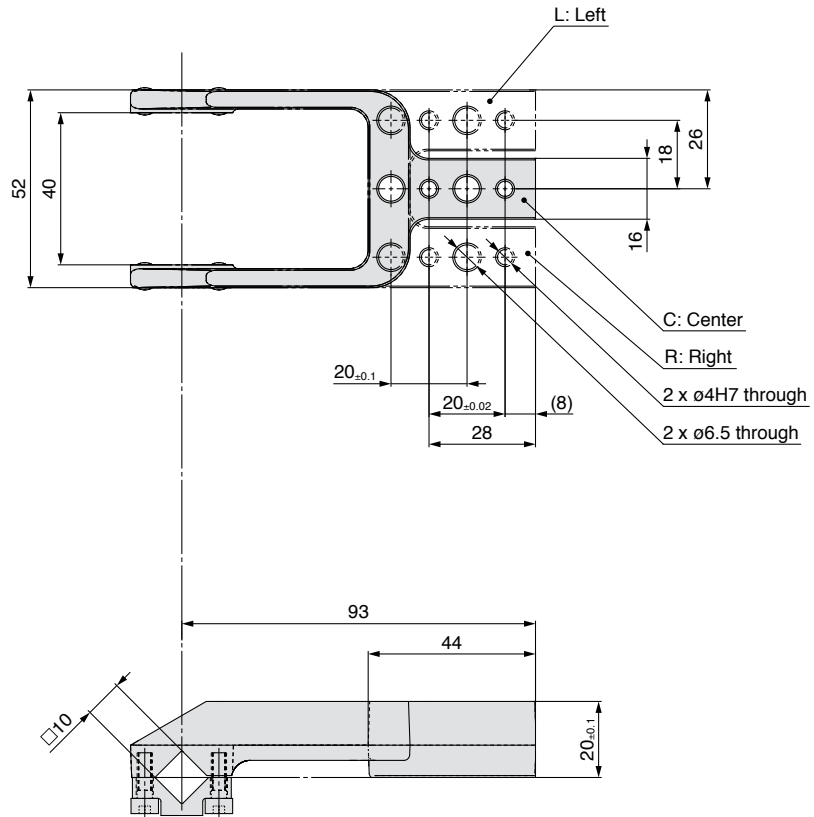

Model Selection

Relation between arm length and clamping force

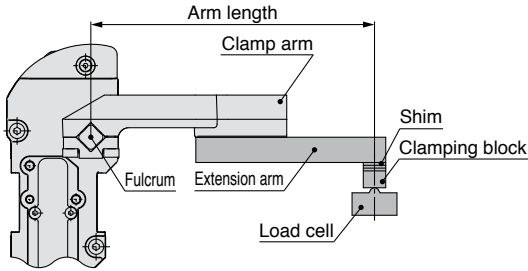

Bore Size: 25

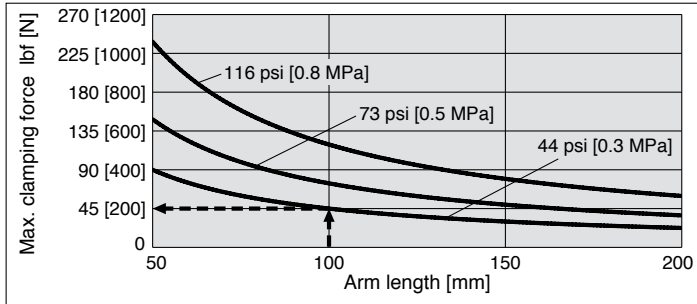

Bore Size: 32

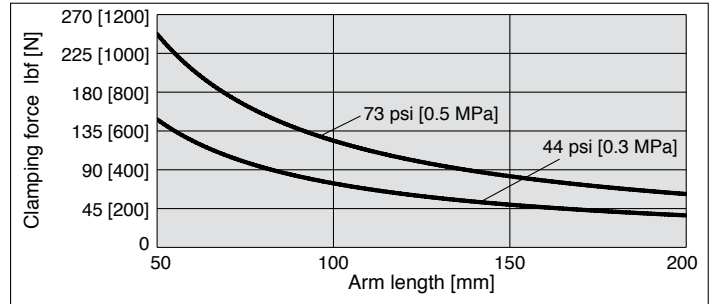

Calculation example

The maximum clamping force when the arm length is 100 mm and the operating pressure is 44 psi [0.3 MPa]:

With an arm length of 100 mm and an operating pressure of 44 psi [0.3 MPa], according to the graph, the maximum clamping force is 45 lbf [200 N].

Allowable arm length

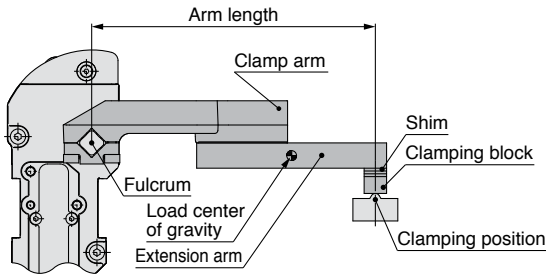

Bore size	Allowable arm length [mm]
25, 32	200

Allowable load mass

The allowable load mass changes depending on the arm opening angle. Be sure to use the product within the allowable values shown in the graph to the right.

* The load indicates the total weight of the clamp arm, extension arm, and clamping block.

* When the operating time is 1 second

Calculation procedure for allowable load mass

1. Calculate the distance L from the fulcrum to the load center of gravity.
2. Check the arm opening angle of the product.
3. Read the allowable load mass from the graph.

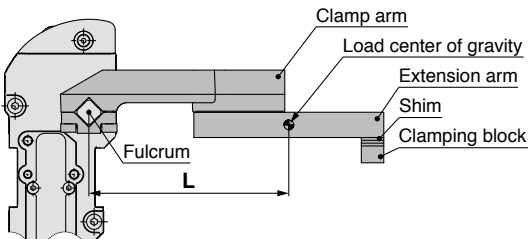

Bore Size: 25, 32

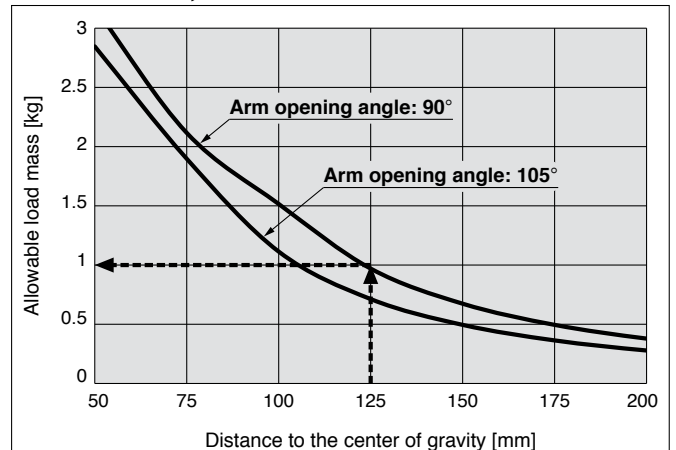

Calculation example

Arm opening angle: 90°, Distance to the center of gravity L: 125 mm
With an arm opening angle of 90° and a 125 mm distance to the center of gravity, according to the graph, the maximum allowable load mass is 1 kg.

Setup Procedure

Precautions

- 1) There is a mechanical difference of 0 to +0.5° at the clamping end as shown in Figure 1. Be sure to make adjustments externally using a shim. Refer to page 9.
- 2) Be sure to use a speed controller, and make adjustments according to the following conditions.

Unclamping to clamping: 1 second or more

Clamping to unclamping: 1 second or more

If excessive kinetic energy is applied, there is a possibility of damage.

- 3) When using a side guide:

Attach the side guide so that lateral loads, such as galling, etc., are not applied to the clamp arm.

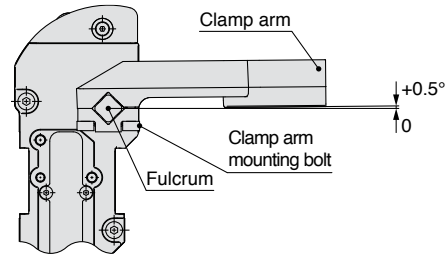
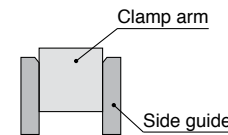

Figure 1



Clamp Arm Mounting Bolt Tightening Torque

Tightening Torque
1.1 to 1.3 lbf-ft [1.5 to 1.8 N·m]

Power clamp cylinder mounting and setup procedure

<Ex. 1 When using clamping force only: When equipped with a workpiece receptacle>

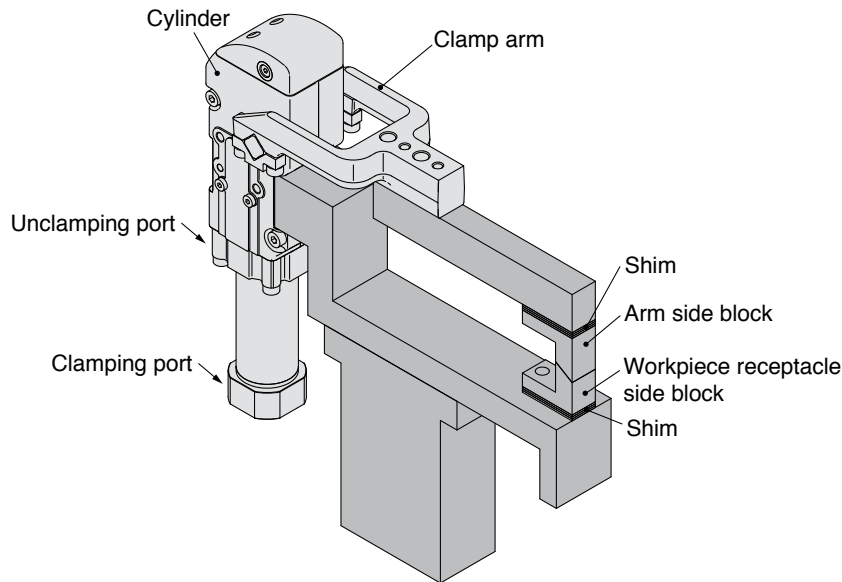

■ Procedure

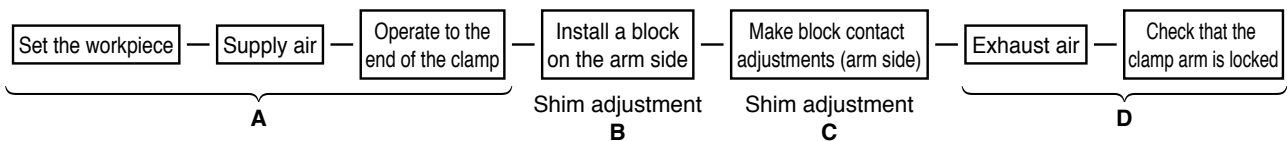

- A) Place the workpiece, supply air to the clamping port without attaching the block on the arm side, and operate the clamp arm to the end of the clamp.
- B) In the state of A), attach the workpiece and the arm side block, and adjust the shim so that there is a space of about 0 mm. During this step, theoretically, there is no clamping force pressing down on the workpiece.
- C) In order to generate a clamping force from the state described in step B), insert an additional shim. The thickness of the shim changes depending on the arm length and the operating pressure. Refer to page 9. Please note that the graph should only be used as a guide, as there is a tolerance of about 10% in the clamp cylinder body.
- D) Exhaust the air while in the clamped state, and confirm that the clamp arm does not open.

Power clamp cylinder mounting and setup procedure

<Ex. 2 When using a hard stop: When not equipped with a workpiece receptacle>

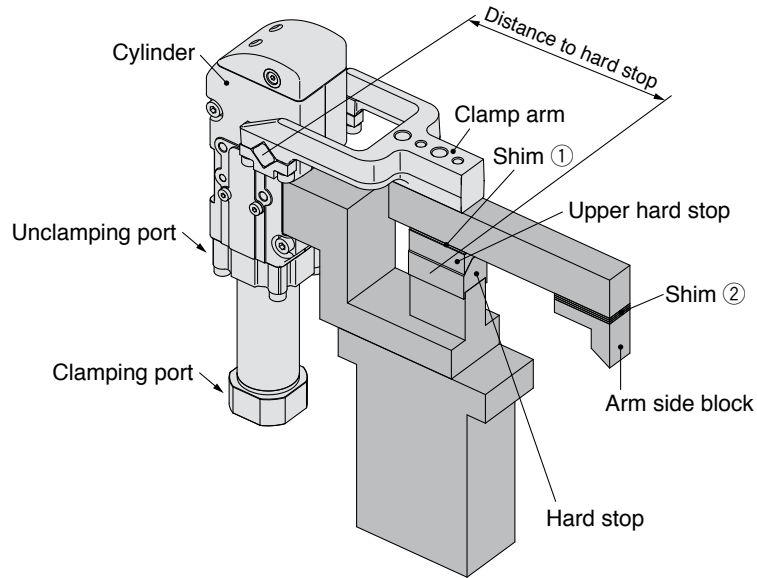

■ Procedure

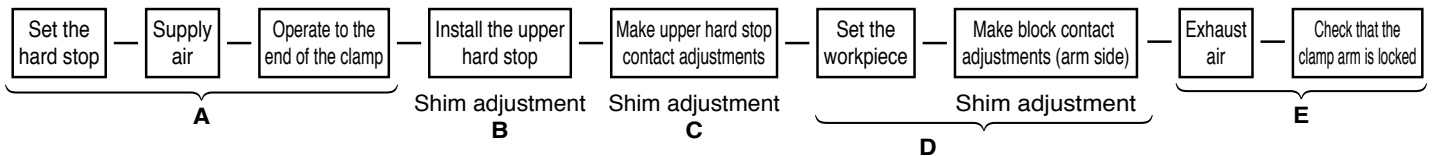

- A) Supply air to the clamping port without installing the upper hard stop, and operate the clamp arm to the end of the clamp.
- B) In the state of A), attach the upper hard stop and adjust the shim ① so that there is a space of about 0 mm between the upper hard stop and the hard stop.
 During this step, theoretically, there is no clamping force applied to the hard stop.
- C) In order to generate a clamping force from the state described in step B), insert an additional shim.
 The thickness of the shim changes depending on the distance to the hard stop and the operating pressure. Refer to page 9, and consider the distance to the hard stop as the arm length.
 Please note that the graph should only be used as a guide, as there is a tolerance of about 10% in the clamp cylinder body.
- D) In the state of C), adjust shim ② so that the arm side block contacts the workpiece.
- E) Exhaust the air while in the clamped state, and confirm that the clamp arm does not open.

Relation between shim thickness and clamping force

- * Use this figure as a guide, as there is a tolerance of about 10% in the clamp cylinder body.
- * When a shim exceeding the peak clamping force position on the graph is inserted, the lock will not be activated when clamped. Insert a shim of the appropriate thickness.
- * The arm length indicates the distance between the clamp arm shaft and the clamping position.

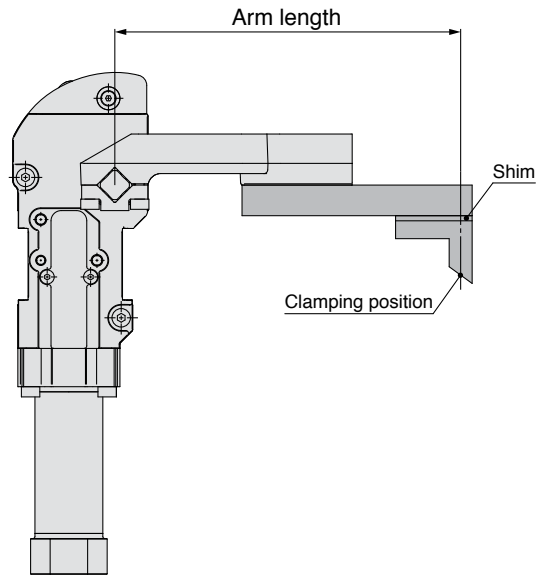

Bore Size: 25

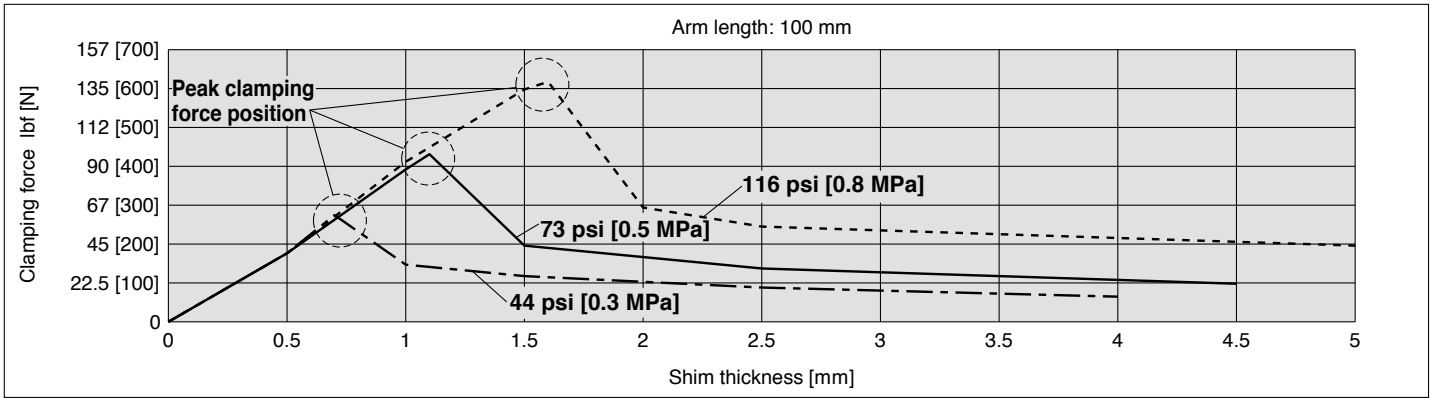

Bore Size: 32

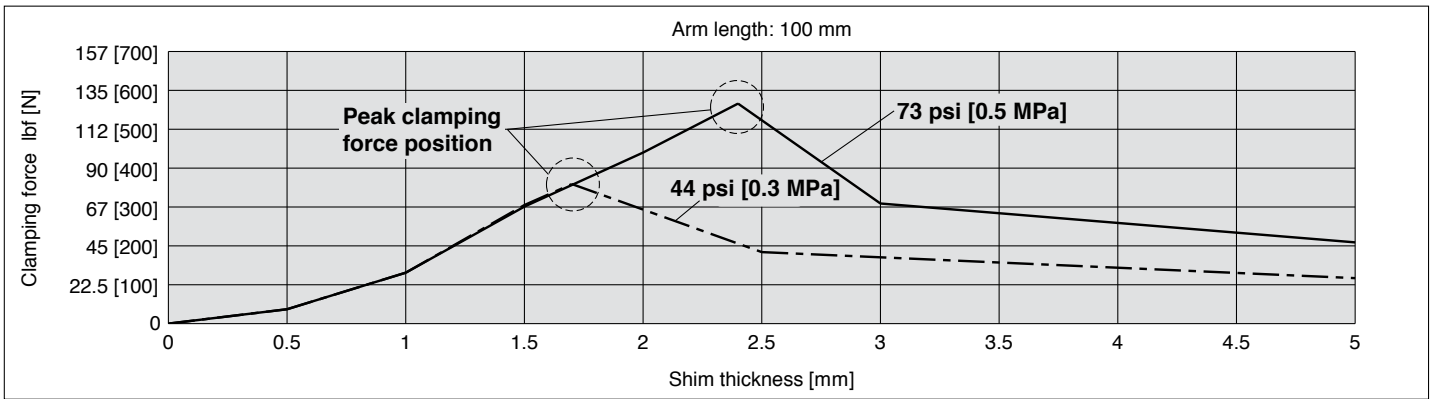



Specific Product Precautions

Be sure to read this before handling the products. For safety instructions and actuator precautions, refer to the “Handling Precautions for SMC Products” and the “Operation Manual” on the SMC website: <http://www.smcworld.com>

⚠ Caution

1. Manual lock release

Be sure to confirm safety before manually releasing the lock, and only perform work **while the air is exhausted**. Otherwise, the clamp arm may operate.

- The lock can be released easily by hitting the round tab on the cover with a plastic hammer.

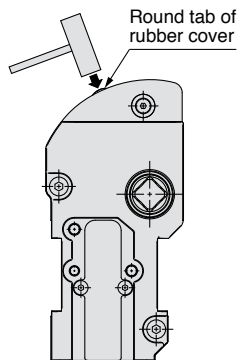

- Provide enough space to perform a manual lock release.

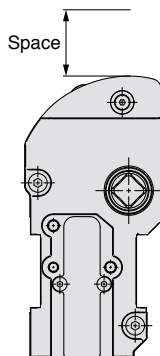

2. Do not disassemble the power clamp cylinder.

The power clamp cylinder consists of a completely sealed structure in order to protect it from welding spatter. Do not disassemble, except for when replacing any of the replaceable parts, as the performance may deteriorate.

⚠ Caution

3. Vertical clamping

When mounting the clamp arm in a vertical clamping position, mount as shown in the figure below.

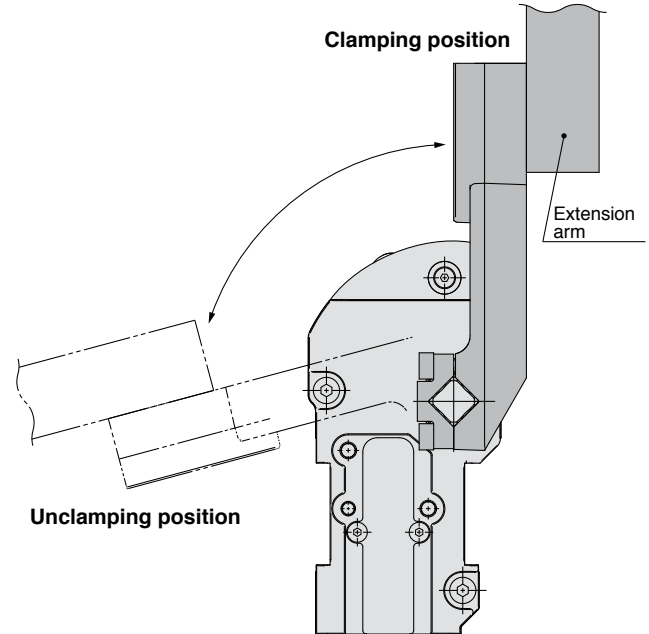

4. Proximity switch output

The switch output signal is output near the clamping end and the unclamping end respectively.

The switch output signal on the clamping side does not output the status where the power clamp cylinder is locked by the toggle mechanism.

Power Clamp Cylinder Variations

* For detailed dimensions and specifications, refer to the **Web Catalog**.



Power Clamp Cylinder/**CKZ3T**-X2734 (Base Type) -X2568□ (With Manually Operated Handle)

Equivalent bore size [mm]	Body material	Port	Arm opening angle	Switch
ø50, ø63	Aluminum	G, NPT, Rc	15°, 30°, 45°, 60°, 75° 90°, 105°, 120°, 135°	TURCK, P&F, None
<ul style="list-style-type: none"> The simple switch adjustment greatly reduces work hours. The switch can be adjusted easily when changing the arm opening angle. With metal switch cassette cover Select from 2 types of top cover (Rubber/Metal) 				



Power Clamp Cylinder/**CKZ3N**-X2742A (Base Type) -X2568□ (With Manually Operated Handle)

Equivalent bore size [mm]	Body material	Port	Arm opening angle	Switch
ø50, ø63	Aluminum	NPT, G, Rc	15°, 30°, 45°, 60°, 75° 90°, 105°, 120°, 135°	TURCK, P&F, None
<ul style="list-style-type: none"> NAAMS Standards compliant Aluminum body with reduced weight The simple switch adjustment greatly reduces work hours. The switch can be adjusted easily when changing the arm opening angle. A metal switch cassette cover is available as an option. Select from 2 types of top cover (Rubber/Metal) 				



Power Clamp Cylinder: Compact Type/**CKZT25, 32**-X2797 (Base Type) -X2798□ (With Manually Operated Handle)

Equivalent bore size [mm]	Body material	Port	Arm opening angle	Switch
ø25, ø32	Aluminum	G	90°, 105°	SENSTRONIC
Compact and lightweight <ul style="list-style-type: none"> Weight: 580 g (ø25) Width: 34 mm, Height: 192.4 mm (ø25) 				



Power Clamp Cylinder/**CKZT**

Equivalent bore size [mm]	Body material	Port	Arm opening angle	Switch
ø40, ø50 ø63, ø80	Aluminum (ø40) Iron (ø50, ø63, ø80)	G, NPT	30°, 45°, 60°, 75°, 90° 105°, 120°, 135°	TURCK, P&F
<ul style="list-style-type: none"> Aluminum body with reduced weight (ø40) 				



Power Clamp Cylinder/**CKZ2N**

Equivalent bore size [mm]	Body material	Port	Arm opening angle	Switch
ø50, ø63, ø80	Iron	NPT, G	30°, 45°, 60°, 75°, 90° 105°, 120°, 135°	TURCK, P&F
<ul style="list-style-type: none"> NAAMS Standards compliant 				

⚠ Safety Instructions Be sure to read the "Handling Precautions for SMC Products" (M-E03-3) and "Operation Manual" before use.

SMC Corporation of America
10100 SMC Blvd., Noblesville, IN 46060
www.smcusa.com

SMC Pneumatics (Canada) Ltd.
www.smc Pneumatics.ca

(800) SMC.SMC1 (762-7621)
e-mail: sales@smcusa.com
International inquiries: www.smcworld.com

