

Profile Design ISO/VDMA Cylinder

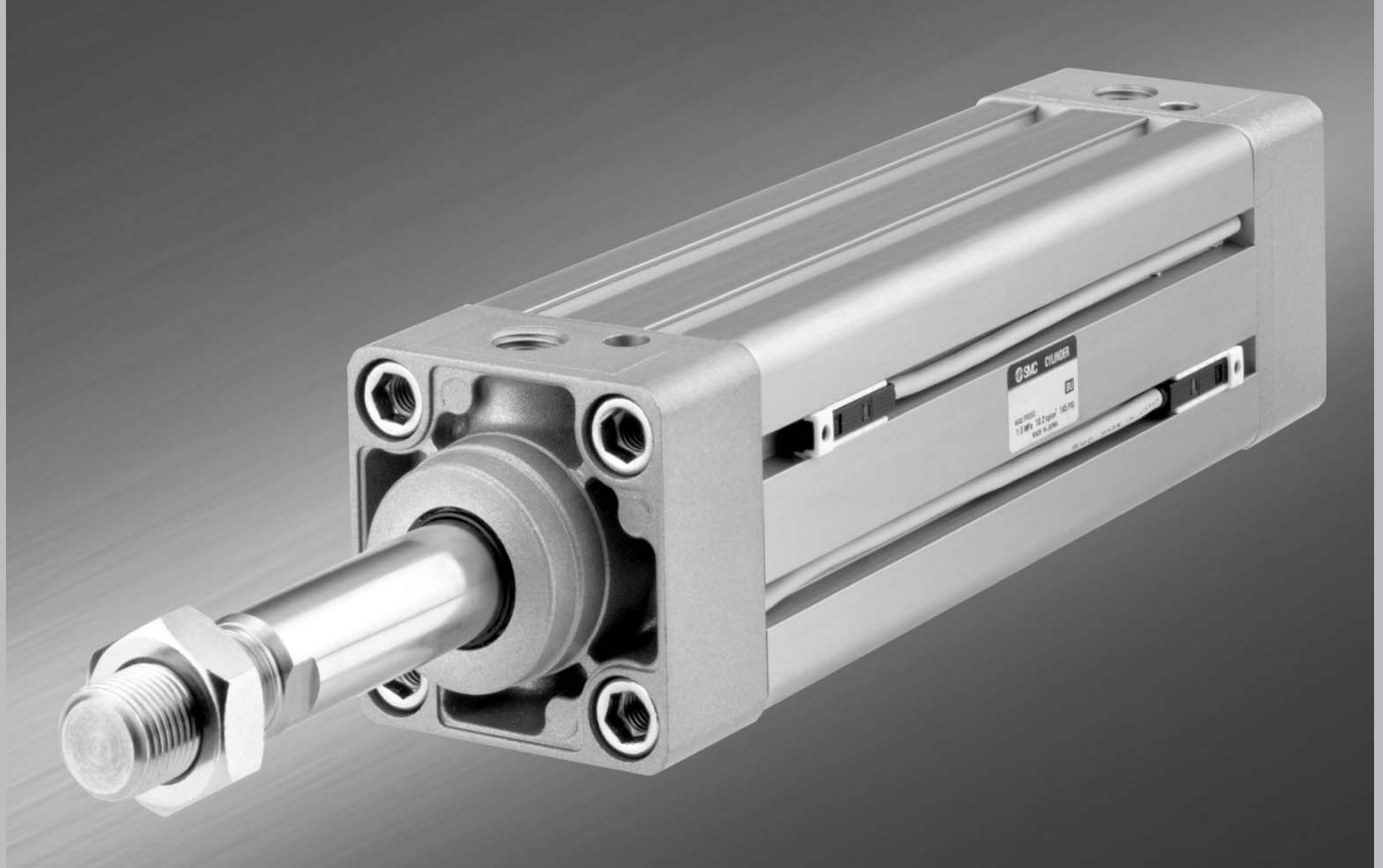

Series CP95

ø32, ø40, ø50, ø63, ø80, ø100

Profile design with enclosed tie-rods



Series Variations

Series	Action	Type		Basic	Standard variations		Option	Bore (mm)	Page
					Built-in magnet	Stainless steel rod			
Standard Series CP95S 	Double acting	Single rod	Non-lube	●	●	●	●	32, 40 50, 63 80, 100	6-13-4
		Double rod	Non-lube	●	●	●			
Non-rotating Rod Series CP95K 	Double acting	Single rod	Non-lube	●	●	(Standard)	●	32, 40 50, 63 80, 100	6-13-14
		Double rod	Non-lube	●	●	(Standard)			

CJ1

CJP

CJ2

CM2

CG1

MB

MB1

CA2

CS1

C76

C85

C95

CP95

NCM

NCA

D-

-X

20-

Data

Series CP95

Improved end of stroke cushion capacity

Piston rod lurching has been eliminated at the end of stroke positions by means of a floating seal mechanism.

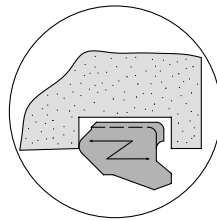

Air cylinder Compact and light design

Die-casting of the covers has reduced the weight by 25%.

Increased kinetic energy absorption

The absorption of kinetic energy has been increased by nearly 30%, through increased cushion volume and the use of a new cushion seal.

Space-saving auto switch mounting

Space is saved by setting switches completely into grooves provided on 4 surfaces.

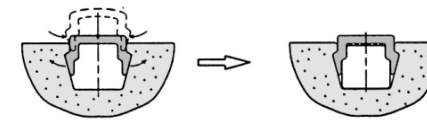

Port aperture

Easy end of stroke cushion valve adjustment

Since adjustment of the cushion valve is performed with a hexagon wrench key, even fine control can be easily accomplished. Furthermore, the cushion valve has been recessed so that it does not protrude from the cover.

Appearance improved by enclosing the tie-rods

Tie-rods are enclosed in an extruded aluminium profile barrel, which is integrated with both end covers to achieve a smooth and attractive appearance.

Dust accumulation can be prevented with optional fastener strips

Auto switch mounting grooves can be covered with resin fastener strips, which adhere tightly to the tube to prevent the entry and accumulation of dirt.

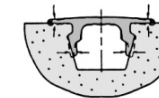

Improved mounting accuracy

High accuracy covers and tie rod nuts simplify the mounting process and also extend cylinder life.

Piston rod deflection reduced

Deflection of the piston rod has been reduced by increasing the precision of the bushing and piston rod, and reducing the tolerances.

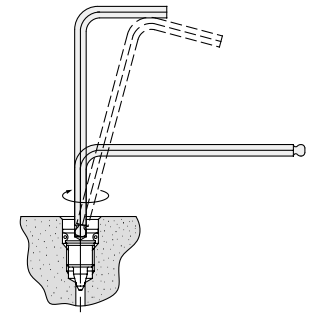
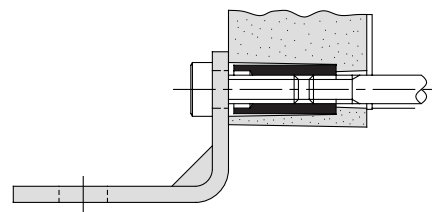

CJ1

CJP

CJ2

CM2

CG1

MB

MB1

CA2

CS1

C76

C85

C95

CP95

NCM

NCA

D-

-X

20-

Data

ISO/VDMA Cylinder: Standard Type Double Acting with End of Stroke Cushioning

Series CP95

ø32, ø40, ø50, ø63, ø80, ø100

How to Order

Without auto switch CP95S **B** **32** — **100** **W**

With auto switch CP95SD **B** **32** — **100** **W** — **Z76** **S**

Built-in magnet — points to **B**

Mounting style

B	Basic/without bracket
L	Axial foot
F	Head side flange
G	Rod side flange
C	Single rear clevis
D	Double rear clevis

Bore size

32	32 mm
40	40 mm
50	50 mm
63	63 mm
80	80 mm
100	100 mm

Stroke (mm)
(Refer to "Standard Stroke" on page 6-13-6.)

Auto switch

Nil	Without auto switch
------------	---------------------

* For the applicable auto switch model, refer to the table below.

Number of auto switches

Nil	2 pcs.
S	1 pc.
3	3 pcs.
n	"n" pcs.

Rod

Nil	Single rod
W	Double rod

Applicable Auto Switch/Tie-rod Mounting Type

Type	Special function	Electrical entry	Indicator light	Wiring (Output)	Load voltage		Auto switch model		Lead wire length (m) ^{Note}			Applicable load	Mounting bracket	
					DC	AC	Electrical entry direction	0.5 (Nil)	3 (L)	5 (Z)				
Reed switch	—	Grommet	Yes	3-wire	—	5 V	—	Vertical	Z76	●	●	—	IC circuit	BMP1-032
				2-wire	—	100 V	—	Z73	●	●	●	—	Relay, PLC	
					5 V, 12 V	100 V or less	—	Z80	●	●	—	IC circuit	—	
Solid state switch	Diagnostic indication (2-color indication)	Grommet	Yes	3-wire (NPN)	24 V	5 V, 12 V	—	Vertical	Y69A	●	●	○	IC circuit	BMP1-032
				Lateral				Y59A	●	●	○	—		
				Vertical				Y7PV	●	●	○			
				Lateral				Y7P	●	●	○			
				Vertical				Y69B	●	●	○			
				Lateral				Y59B	●	●	○			
	Vertical	Y7NWV	●	●	○	IC circuit								
Water resistant (2-color indication)	—	Grommet	Yes	3-wire (NPN)	24 V	5 V, 12 V	—	Vertical	Y7NW	●	●	○	IC circuit	BMP1-032
				Lateral				Y7PWV	●	●	○	—		
				Vertical				Y7PW	●	●	○			
Water resistant (2-color indication)	—	Grommet	Yes	3-wire (PNP)	24 V	12 V	—	Vertical	Y7BWV	●	●	○	IC circuit	BMP1-032
				Lateral				Y7BW	●	●	○	—		
Water resistant (2-color indication)	—	Grommet	Yes	2-wire	24 V	12 V	—	Vertical	Y7BA	—	●	—	—	BMP1-032
				Lateral				—	—	—	—			

* Lead wire length symbols: 0.5 m Nil (Example) A53
 3 m L (Example) A53L
 5 m Z (Example) A53Z

○: Manufactured upon receipt of order.

ISO/VDMA Cylinder: Standard Type Double Acting w/ End of Stroke Cushioning **Series CP95**

Accessory

Mounting Accessory, Cylinder

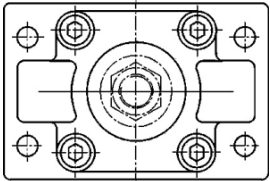
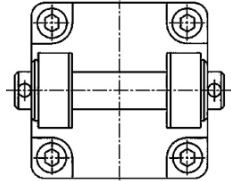
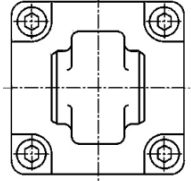
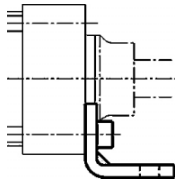
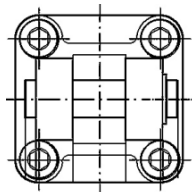
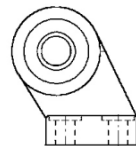
Bore size (mm)	F Rod/Head side flange	D Female head side clevis (Corresponds to E accessories)	C Male head side clevis	
		 <p>Supplied with 4 screws</p>	 <p>Supplied with bolt, safety device and 4 screws</p>	 <p>Supplied with 4 screws</p>
32	F5032	D5032	Plain	
40	F5040	D5040	With ball joint	
50	F5050	D5050	C5032	
63	F5063	D5063	C5040	
80	F5080	D5080	C5050	
100	F5100	D5100	C5063	
			C5080	
			C5100	
	See page 6-13-10 and 18 for dimensions.	See pages 6-13-10 to 11 and 18 for dimensions.	See pages 6-13-10 to 11 and 18 for dimensions. <small>(Note) See page 6-13-11 for male head side clevis with swivel CR50.</small>	
Bore size (mm)	L Foot	DS Female head side clevis (for ES accessory)	ES Angled head side clevis with ball joint	E Angled head side clevis
		 <p>Supplied with two pieces</p>		
32	L5032	DS5032	ES5032	E5032
40	L5040	DS5040	ES5040	E5040
50	L5050	DS5050	ES5050	E5050
63	L5063	DS5063	ES5063	E5063
80	L5080	DS5080	ES5080	E5080
100	L5100	DS5100	ES5100	E5100
	See page 6-13-10 and 18 for dimensions.	See page 6-13-12 for dimensions.	See page 6-13-12 for dimensions.	See page 6-13-11 for dimensions.

Mounting Accessory, Rod

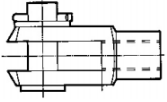
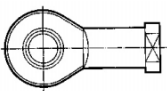
Bore size (mm)	GKM Rod clevis ISO 8140	KJ Piston rod ball joint ISO 8139	JA Floating joint
		 <p>Supplied with bolts and safety devices</p>	
32	GKM10-20	KJ10D	JA30-10-125
40	GKM12-24	KJ12D	JA40-12-125
50	GKM16-32	KJ16D	JA50-16-150
63	GKM16-32	KJ16D	JA50-16-150
80	GKM20-40	KJ20D	JAH50-20-150
100	GKM20-40	KJ20D	JAH50-20-150
	See page 6-13-13 for dimensions.	See page 6-13-13 for dimensions.	See page 6-13-13 for dimensions.

CJ1

CJP

CJ2

CM2

CG1

MB

MB1

CA2

CS1

C76

C85

C95

CP95

NCM

NCA

D-

-X

20-

Data

Series CP95

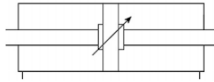
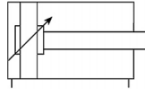

Minimum Stroke for Auto Switch Mounting

Refer to page 6-13-20 for "Minimum Stroke for Auto Switch Mounting".



Made to Order Specifications (For details, refer to page 6-17-19.)

Symbol	Specifications
-XB6	Heat resistant cylinder (150°C)
-XB13	Low speed cylinder (5 to 50 mm/s)
-XC22	Fluoro rubber seals

Specifications

Bore size (mm)	32	40	50	63	80	100
Action	Double acting					
Fluid	Air					
Proof pressure	1.5 MPa					
Max. operating pressure	1.0 MPa					
Min. operating pressure	0.05 MPa					
Ambient and fluid temperature	Without auto switch: -10 to 70°C (No freezing) With auto switch: -10 to 60°C (No freezing)					
Lubrication	Not required (Non-lube)					
Operating piston speed	50 to 1000 mm/s					
Allowable stroke tolerance	Up to 250: $^{+1.0}_0$, 251 to 1000: $^{+1.4}_0$, 1001 to 1500: $^{+1.8}_0$					
Cushion	Both ends (Air cushion)					
Thread tolerance	JIS Class 2					
Port size	G 1/8	G 1/4	G 1/4	G 3/8	G 3/8	G 1/2
Mounting	Basic style, Axial foot style, Rod side flange style, Head side flange style, Single clevis style, Double clevis style					

Standard Stroke

Bore size (mm)	Standard stroke (mm)	Max. * stroke
32	25, 50, 80, 100, 125, 160, 200, 250, 320, 400, 500	700
40	25, 50, 80, 100, 125, 160, 200, 250, 320, 400, 500	800
50	25, 50, 80, 100, 125, 160, 200, 250, 320, 400, 500, 600	1200
63	25, 50, 80, 100, 125, 160, 200, 250, 320, 400, 500, 600	1200
80	25, 50, 80, 100, 125, 160, 200, 250, 320, 400, 500, 600, 700, 800	1400
100	25, 50, 80, 100, 125, 160, 200, 250, 320, 400, 500, 600, 700, 800	1500

Intermediate strokes are available.

* Please consult with SMC for longer strokes.

Accessory

Mounting		Basic style	Foot style	Rod side flange style	Head side flange style	Single clevis style	Double clevis style
Standard	Rod end nut	●	●	●	●	●	●
	Clevis pin	—	—	—	—	—	●
Option	Single clevis	●	●	●	●	●	●
	Double clevis (With pin)	●	●	●	●	●	●
	Rod boot	●	●	●	●	●	●

ISO/VDMA Cylinder: Standard Type Double Acting w/ End of Stroke Cushioning **Series CP95**

Theoretical Output



Bore size (mm)	Rod diameter (mm)	Operating direction	Piston area (mm ²)	Operating pressure (MPa)									
				0.2	0.3	0.4	0.5	0.6	0.7	0.8	0.9	1.0	
32	12	OUT	804	161	241	322	402	482	563	643	724	804	
		IN	691	138	207	276	346	415	484	553	622	691	
40	16	OUT	1257	251	377	503	629	754	880	1006	1131	1257	
		IN	1056	211	317	422	528	634	739	845	950	1056	
50	20	OUT	1963	393	589	785	982	1178	1374	1570	1767	1963	
		IN	1649	330	495	660	825	989	1154	1319	1484	1649	
63	20	OUT	3117	623	935	1247	1559	1870	2182	2494	2805	3117	
		IN	2803	561	841	1121	1402	1682	1962	2242	2523	2803	
80	25	OUT	5027	1005	1508	2011	2514	3016	3519	4022	4524	5027	
		IN	4536	907	1361	1814	2268	2722	3175	3629	4082	4536	
100	30	OUT	7854	1571	2356	3142	3927	4712	5498	6283	7068	7854	
		IN	7147	1429	2144	2859	3574	4288	5003	5718	6432	7147	

Note) Theoretical out put (N) = Pressure (MPa) x Piston area (mm²)

Weight/Aluminum Tube

Bore size (mm)		32	40	50	63	80	100
Basic weight	Basic style	0.59	0.87	1.44	2.00	3.37	4.45
	Foot style	0.16	0.20	0.38	0.46	0.89	1.09
	Flange style	0.20	0.23	0.47	0.58	1.30	1.81
	Single clevis style	0.16	0.23	0.37	0.60	1.07	1.73
	Double clevis style	0.20	0.32	0.45	0.71	1.28	2.11
Additional weight per each 50 mm of stroke	All mounting brackets	0.11	0.16	0.26	0.27	0.42	0.56
Accessory	Single rod clevis	0.07	0.11	0.22	0.22	0.40	0.40
	Double clevis (With pin)	0.09	0.15	0.34	0.34	0.69	0.69

Calculation: (Example) CP95SD40-100

- Basic weight 0.87 (kg) (Basic, ø40)
 - Mounting 0.32 (kg) (Double clevis)
 - Additional weight ... 0.16 (kg/50 st)
 - Cylinder stroke 100 (st)
- 0.87 + 0.16 x 100 ÷ 50 + 0.32 = 1.51 kg

Allowable Kinetic Energy

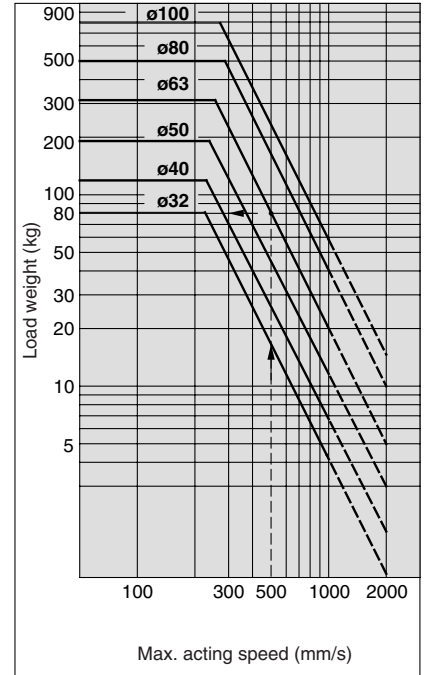

Example: Load limit at rod end when air cylinder ø63 is actuated with max. actuating speed 500 mm/s. See the intersection of lateral axis 500 mm/s and ø63 line, and extend the intersection to left. Thus the allowable load is 80 kg.

CJ1

CJP

CJ2

CM2

CG1

MB

MB1

CA2

CS1

C76

C85

C95

CP95

NCM

NCA

D-

-X

20-

Data

Series CP95

Construction

[First angle projection]

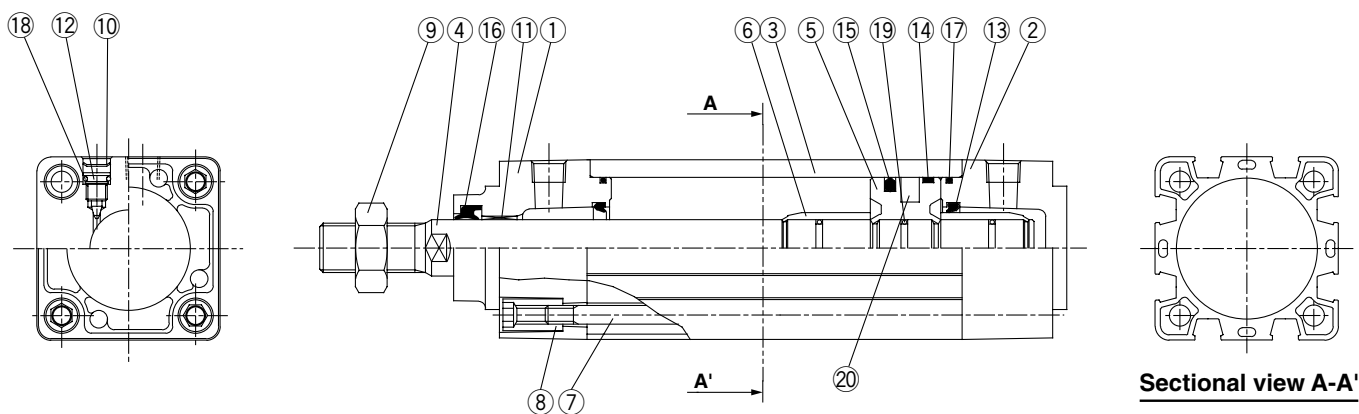

Component Parts

No.	Description	Material
①	Rod cover	Aluminum die-casted
②	Head cover	Aluminum die-casted
③	Cylinder tube	Aluminum alloy
④	Piston rod	Carbon steel
⑤	Piston	Aluminum alloy
⑥	Cushion ring	Brass
⑦	Tie-rod	Steel
⑧	Tie-rod nut	Steel
⑨	Rod end nut	Steel
⑩	Snap ring	Steel for spring
⑪	Bushing	Lead-bronze casted
⑫	Cushion valve	Steel
⑬	Cushion seal	Urethan rubber
⑭	Wear ring	Resin
⑮	Piston seal	NBR
⑯	Rod seal	NBR
⑰	Cylinder tube gasket	NBR
⑱	Cushioning valve seal	NBR
⑲	Piston/rod gasket	NBR
⑳	Magnet	

Replacement Parts: Seal Kit

Bore size (mm)	Part no.	Contents
32	CS95-32	Kits include items ⑬ to ⑰.
40	CS95-40	
50	CS95-50	
63	CS95-63	
80	CS95-80	
100	CS95-100	

* Seal kits consist of items ⑬ to ⑰ contained in one kit, and can be ordered using the order number for each respective tube bore size.

ISO/VDMA Cylinder: Standard Type Double Acting w/ End of Stroke Cushioning **Series CP95**

Dimensions: Without Mounting Bracket

[First angle projection]

CP95S□B Bore size Stroke

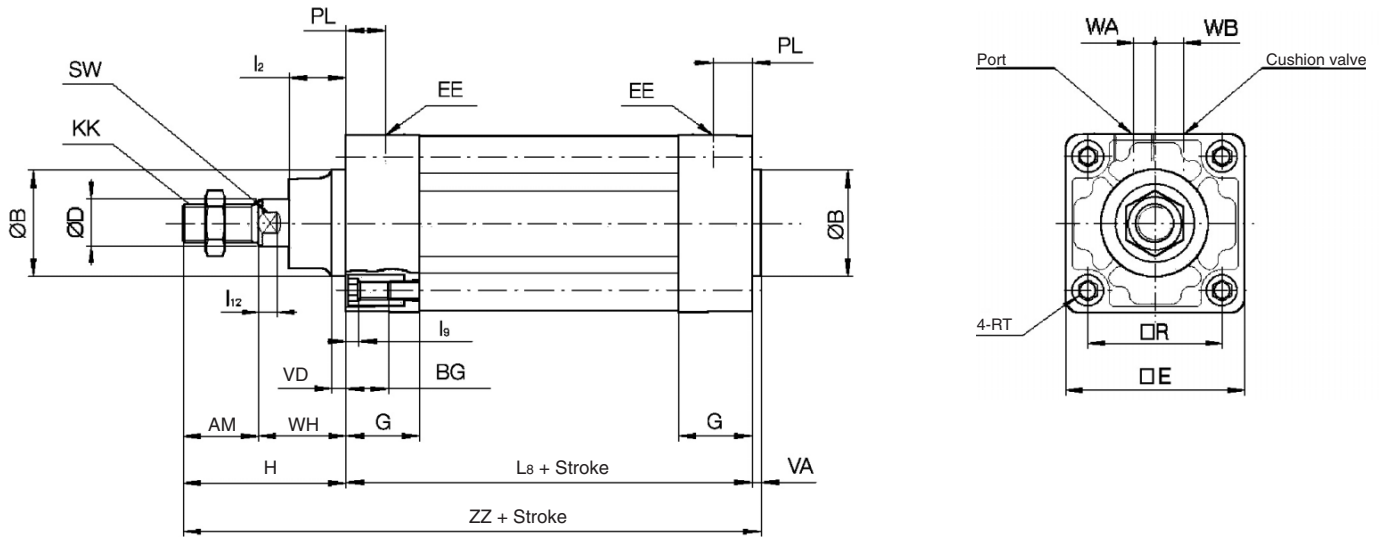

CP95S□B Bore size Stroke W

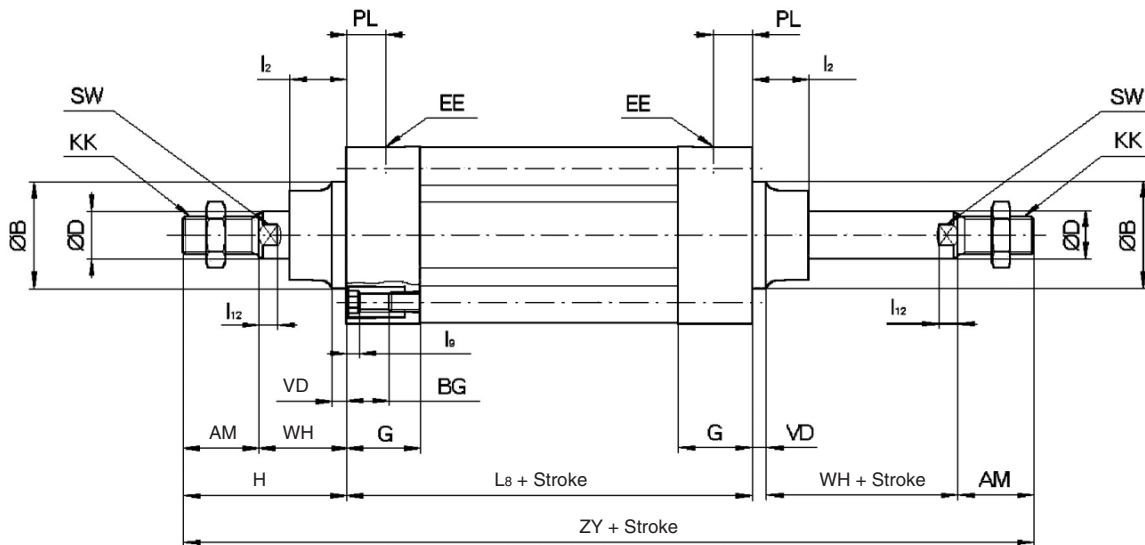

CJ1

CJP

CJ2

CM2

CG1

MB

MB1

CA2

CS1

C76

C85

C95

CP95

NCM

NCA

D-

-X

20-

Data

Bore size (mm)	AM	ϕB	ϕD	EE	PL	RT	l_{12}	KK	SW	G	BG (MIN)	L_8	VD	VA	WA	WB	WH	ZZ	ZY	ϕE	ϕR	l_2	l_9
32	22	30	12	G 1/8	13	M6 x 1	6	M10 x 1.25	10	27	16	94	4	4	4	6.5	26	146	190	46	32.5	15	4
40	24	35	16	G 1/4	14	M6 x 1	6.5	M12 x 1.25	13	27	16	105	4	4	4	9	30	163	213	52	38	17	4
50	32	40	20	G 1/4	15.5	M8 x 1.25	8	M16 x 1.5	16	31.5	16	106	6	4	5	10.5	37	179	244	65	46.5	24	5
63	32	45	20	G 3/8	16.5	M8 x 1.25	8	M16 x 1.5	16	31.5	16	121	6	4	9	12	37	194	259	75	56.5	24	5
80	40	45	25	G 3/8	19	M10 x 1.5	10	M20 x 1.5	21	38	16	128	8	4	11.5	14	46	218	300	95	72	30	5
100	40	55	30	G 1/2	19	M10 x 1.5	10	M20 x 1.5	21	38	16	138	8	4	17	15	51	233	320	114	89	32	5

Series CP95

Dimensions: Cylinder Mounting Accessory L, F, G, C and D

[First angle projection]

Mounting style (L)

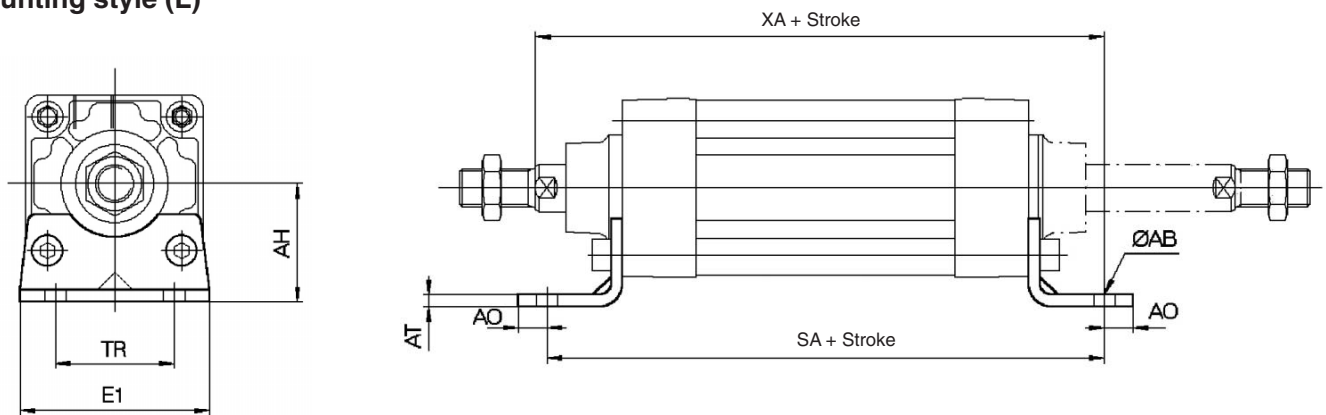

Mounting style (F, G)

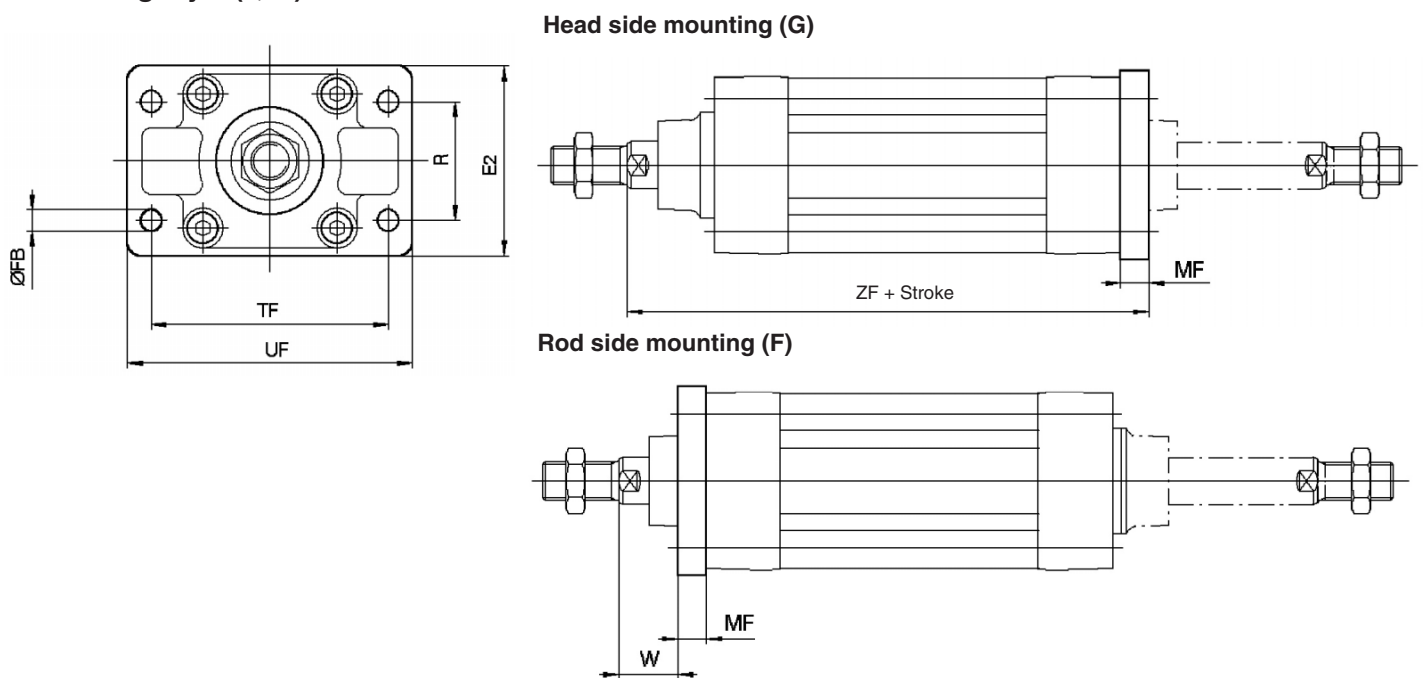

Mounting style (C)

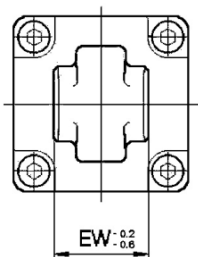

Mounting style (D)

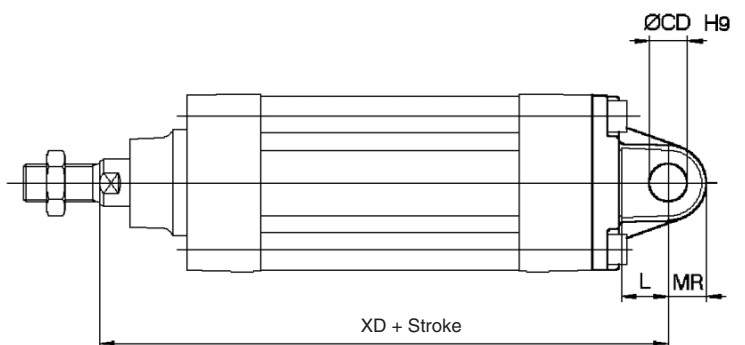
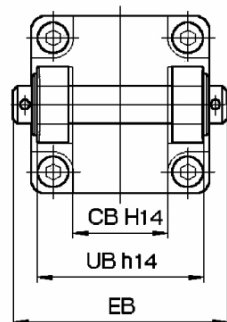

Bore size (mm)	E ₁	R	W	MF	ZF	øFB	CD	EB	L	XD	UB	CB	EW	MR	TR	AO	AT	XA	SA	AH	øAB	TF	UF	E ₂
32	48	32	16	10	130	7	10	65	12	142	45	26	26	9.5	32	10	4.5	144	142	32	7	64	79	50
40	55	36	20	10	145	9	12	75	15	160	52	28	28	12	36	11	4.5	163	161	36	10	72	90	55
50	68	45	25	12	155	9	12	80	15	170	60	32	32	12	45	12	5.5	175	170	45	10	90	110	70
63	80	50	25	12	170	9	16	90	20	190	70	40	40	16	50	12	5.5	190	185	50	10	100	120	80
80	100	63	30	16	190	12	16	110	20	210	90	50	50	16	63	14	6.5	215	210	63	12	126	153	100
100	120	75	35	16	205	14	20	140	25	230	110	60	60	20	75	16	6.5	230	220	71	14.5	150	178	120

ISO/VDMA Cylinder: Standard Type Double Acting w/ End of Stroke Cushioning **Series CP95**

Dimensions: Cylinder Mounting Accessory C, D, E and CR

[First angle projection]

Mounting style (C)

Mounting style (D)

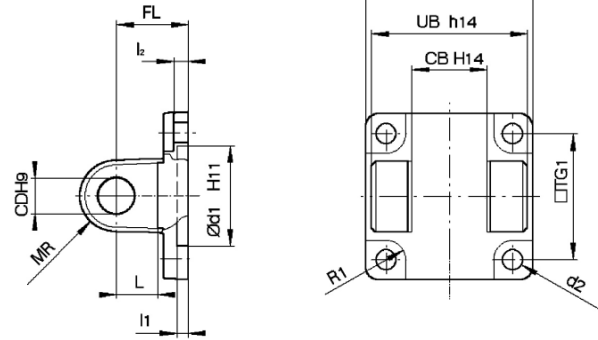
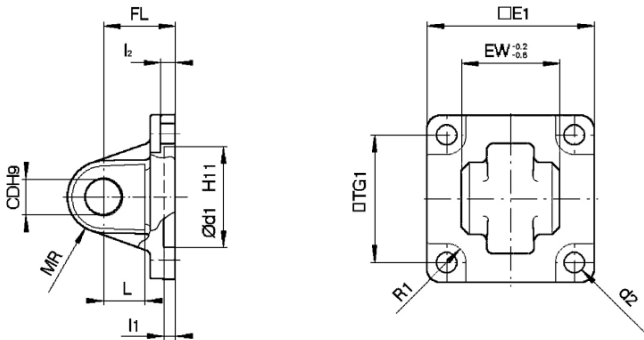

Bore size (mm)	□E1	EW	□TG1	FL	l ₁	L	l ₂	ød ₁	CD	MR	d ₂	R ₁	□E2	UB	CB
32	45	26	32.5	22	5	12	5.5	30	10	9.5	6.6	6.5	48	45	26
40	51	28	38	25	5	15	5.5	35	12	12	6.6	6.5	56	52	28
50	64	32	46.5	27	5	15	6.5	40	12	12	9	8.5	64	60	32
63	74	40	56.5	32	5	20	6.5	45	16	16	9	8.5	75	70	40
80	94	50	72	36	5	20	10	45	16	16	11	11	95	90	50
100	113	60	89	41	5	25	10	55	20	20	11	12	115	110	60

Mounting style (E)

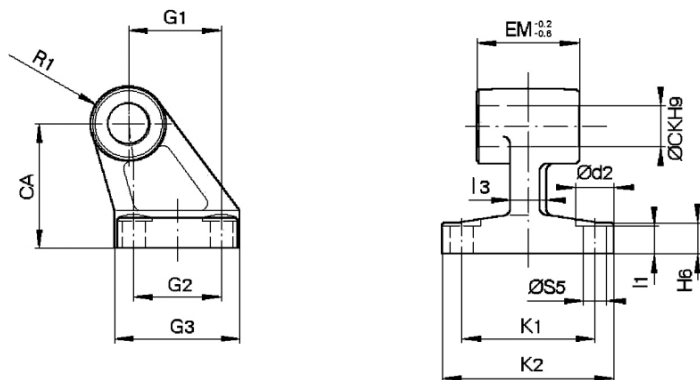

Bore size (mm)	ød ₂	øCK	øS ₅	K ₁	K ₂	l ₃	G ₁	l ₁	G ₂	EM	G ₃	CA	H ₆	R ₁
32	11	10	6.6	38	51	10	21	7	18	26	31	32	8	10
40	11	12	6.6	41	54	10	24	9	22	28	35	36	10	11
50	15	12	9	50	65	12	33	11	30	32	45	45	12	12
63	15	16	9	52	67	14	37	11	35	40	50	50	12	15
80	18	16	11	66	86	18	47	12.5	40	50	60	63	14	15
100	18	20	11	76	96	20	55	13.5	50	60	70	71	15	19

Mounting style (CR): Head side clevis with ball joint

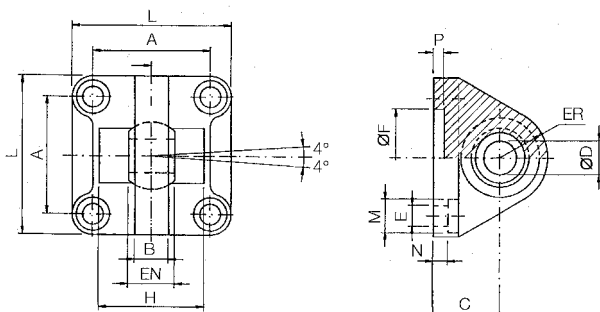

Bore size (mm)	A	B	C	D	EN	ER	F	E	L	M	N	P	H
	±0.2	max	±0.2	H7	-0.1	max	H11	H13		H13	±0.5		±0.5
32	32.5	10.5	22	10	14	15	30	6.6	45	10.5	5.5	5	—
40	38	12	25	12	16	18	35	6.6	55	11	5.5	5	—
50	46.5	15	27	16	21	20	40	9	65	15	6.5	5	51
63	56.5	15	32	16	21	23	45	9	75	15	6.5	5	—
80	72	18	36	20	25	27	45	11	95	18	10	5	—
100	89	18	41	20	25	30	55	11	115	18	10	5	—

CJ1

CJP

CJ2

CM2

CG1

MB

MB1

CA2

CS1

C76

C85

C95

CP95

NCM

NCA

D-

-X

20-

Data

Series CP95

Dimensions: Cylinder Mounting Accessory DS and ES

[First angle projection]

Mounting style (DS)

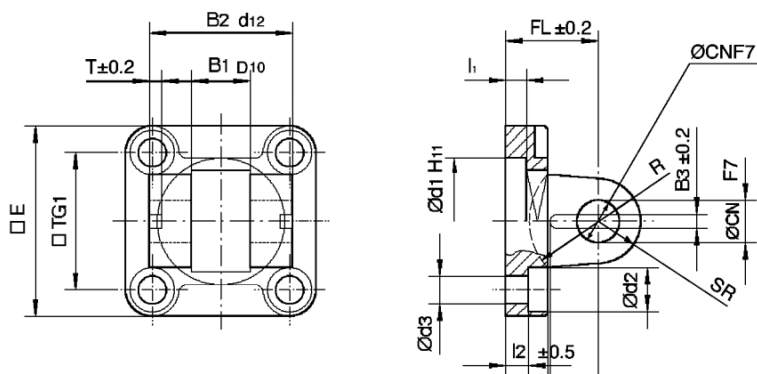

Bore size (mm)	□E	B ₁	B ₂	B ₃	□TG ₁	T	l ₁ (min)	l ₂	FL	H	ød ₁	ød ₂	ød ₃	CN	SR (max)	R
32	45	14	34	3.3	32.5	3	5	5.5	22	10	30	10.5	6.6	10	11	17
40	55	16	40	4.3	38	4	5	5.5	25	10	35	11	6.6	12	13	20
50	65	21	45	4.3	46.5	4	5	6.5	27	10	40	15	9	16	18	22
63	75	21	51	4.3	56.5	4	5	6.5	32	12	45	15	9	16	18	25
80	95	25	65	4.3	72	4	5	10	36	16	45	18	11	20	22	30
100	115	25	75	6.3	89	4	5	10	41	16	55	18	11	20	22	32

Mounting style (ES)

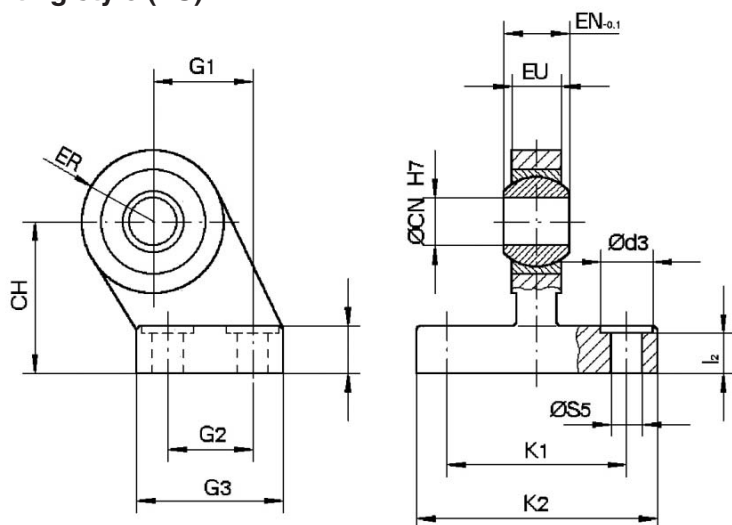

Bore size (mm)	ød ₃	øCN	øS ₅	K ₁	K ₂	l ₂	G ₁	G ₂	G ₃	EN	EU	CH	H ₆	ER
32	11	10	6.6	38	51	8.5	21	18	31	14	10.5	32	10	15
40	11	12	6.6	41	54	8.5	24	22	35	16	12	36	10	18
50	15	16	9	50	65	10.5	33	30	45	21	15	45	12	20
63	15	16	9	52	67	10.5	37	35	50	21	15	50	12	23
80	18	20	11	66	86	11.5	47	40	60	25	18	63	14	27
100	18	20	11	76	96	12.5	55	50	70	25	18	71	15	30

ISO/VDMA Cylinder: Standard Type Double Acting w/ End of Stroke Cushioning **Series CP95**

Dimensions: Piston Rod Mounting Accessory

[First angle projection]

Floating Joint JA

Steel

Bore size (mm)	M	Part no.	A	B	C	øD	E	F	G	H	P	U	Load (kN)	Weight (g)	Angle
32	M10 x 1.25	JA30-10-125	49.5	19.5	—	24	5	8	8	17	9	0.5	2.5	70	± 5°
40	M12 x 1.25	JA40-12-125	60	20	—	31	6	11	11	22	13	0.75	4.4	160	
50, 63	M16 x 1.5	JA50-16-150	71.5	22	—	41	7.5	14	13.5	27	15	1.0	11	300	
80, 100	M20 x 1.5	JAH50-20-150	101	28	31	59.5	11.5	24	16	32	18	2.0	18	1080	

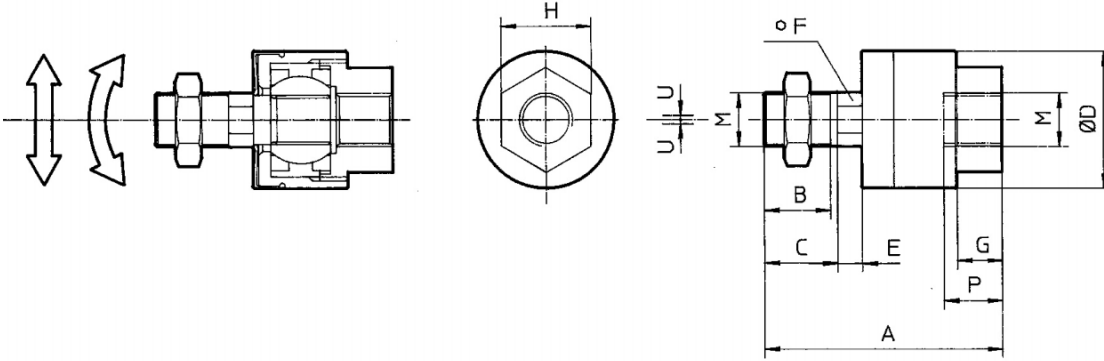

Rod Clevis GKM (ISO 8140), Supplied with Bolt and Safety Device

Steel

Bore size (mm)	e	Part no.	b	d	øf h11	l1	c	a
32	M10 x 1.25	GKM10-20	10 ^{+0.50} / _{+0.15}	40	10	52	20	20
40	M12 x 1.25	GKM12-24	12 ^{+0.50} / _{+0.15}	48	12	62	24	24
50, 63	M16 x 1.5	GKM16-32	16 ^{+0.50} / _{+0.15}	64	16	83	32	32
80, 100	M20 x 1.5	GKM20-40	20 ^{+0.60} / _{+0.15}	80	20	105	40	40

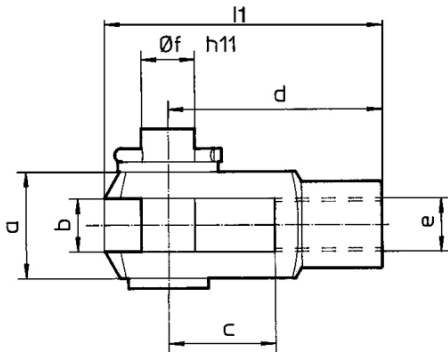

Piston Rod Ball Joint KJ (ISO 8139)

Steel

Bore size (mm)	d3	Part no.	ød1 H9	h	d6 (max)	b1	l	a	l3
32	M10 x 1.25	KJ10D	10	43	28	14	20	13°	14
40	M12 x 1.25	KJ12D	12	50	32	16	22	13°	16
50, 63	M16 x 1.5	KJ16D	16	64	42	21	28	15°	26
80, 100	M20 x 1.5	KJ20D	20	77	50	25	33	15°	26

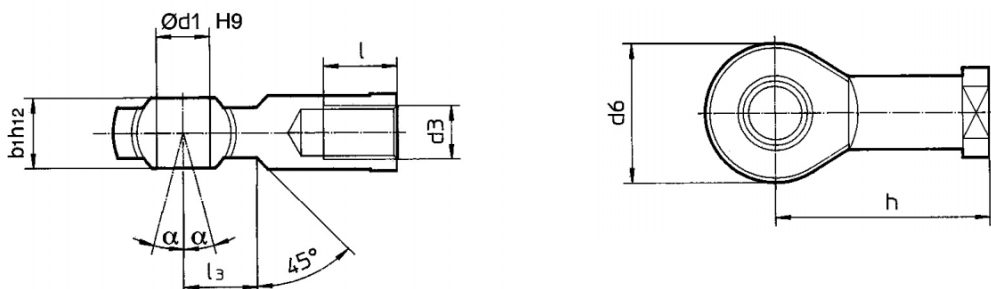

CJ1

CJP

CJ2

CM2

CG1

MB

MB1

CA2

CS1

C76

C85

C95

CP95

NCM

NCA

D-

-X

20-

Data

ISO/VDMA Cylinder: Non-rotating Type Double Acting with End of Stroke Cushioning

Series CP95K

ø32, ø40, ø50, ø63, ø80, ø100

How to Order

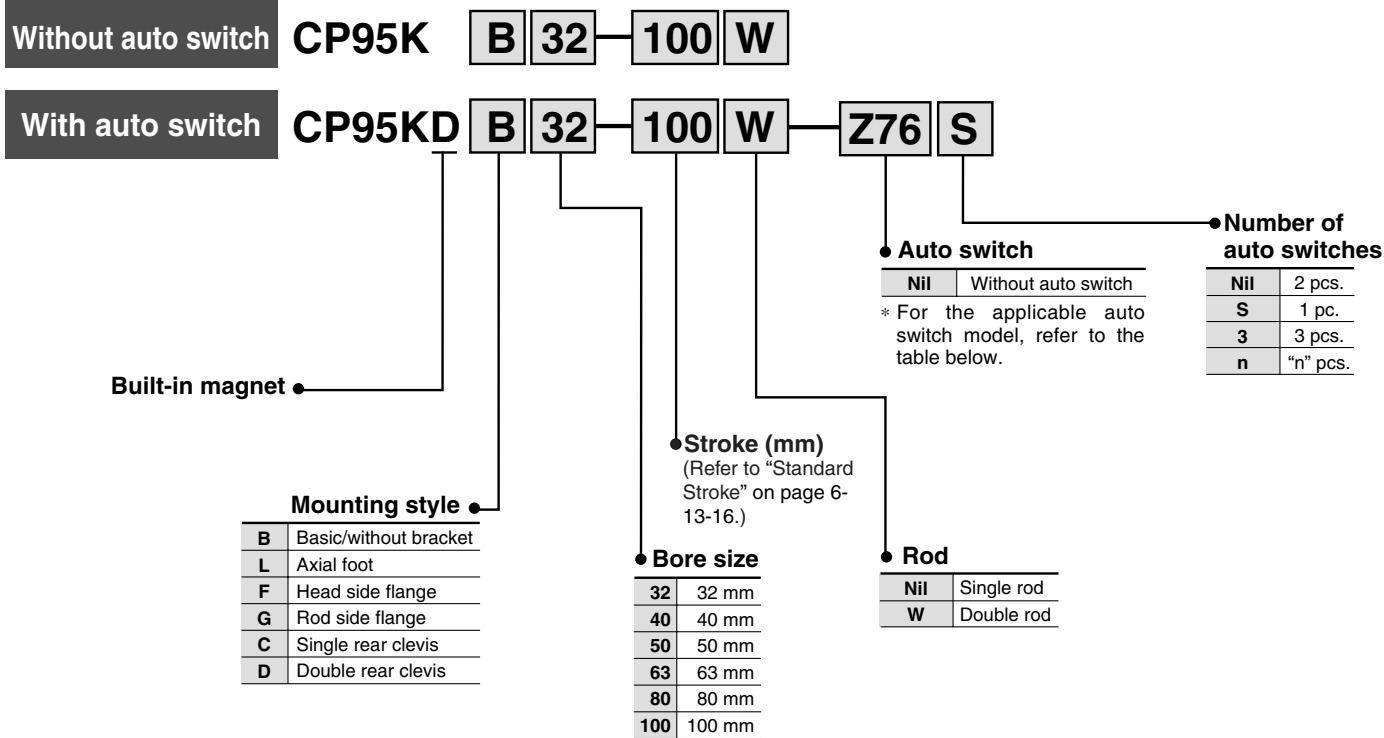

Applicable Auto Switch/Tie-rod Mounting Type

Type	Special function	Electrical entry	Indicator light	Wiring (Output)	Load voltage		Auto switch model		Lead wire length (m) ^{Note}			Applicable load	Mounting bracket	
					DC	AC	Electrical entry direction	0.5 (Nil)	3 (L)	5 (Z)				
Reed switch	—	Grommet	Yes	3-wire	—	5 V	—	Vertical	Z76	●	●	—	IC circuit	BMP1-032
				2-wire	—	100 V	—	Z73	●	●	●	—	Relay, PLC	
					5 V, 12 V	100 V or less	—	Z80	●	●	—	IC circuit		
Solid state switch	Diagnostic indication (2-color indication)	Grommet	Yes	3-wire (NPN)	24 V	5 V, 12 V	—	Vertical	Y69A	●	●	○	IC circuit	BMP1-032
				Lateral				Y59A	●	●	○	Relay, PLC		
				Vertical				Y7PV	●	●	○			
				Lateral				Y69B	●	●	○	—		
				Vertical				Y7NWV	●	●	○	IC circuit		
				Lateral				Y7NW	●	●	○			
				Vertical				Y7PWV	●	●	○			
Water resistant (2-color indication)	—	—	—	2-wire	12 V	—	Vertical	Y7BWV	●	●	○	—	—	
—	—	—	—	—	—	—	Vertical	Y7BA	—	●	—	—	—	

* Lead wire length symbols: 0.5 m Nil (Example) A53
 3 m L (Example) A53L
 5 m Z (Example) A53Z

○: Manufactured upon receipt of order.

ISO/VDMA Cylinder: Non-rotating Type Double Acting w/ End of Stroke Cushioning **Series CP95K**

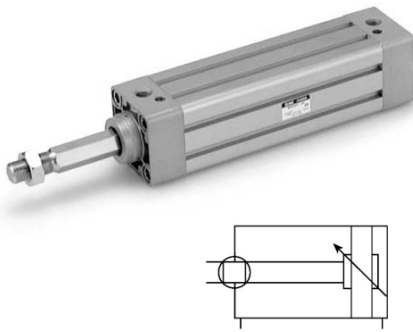

Specifications

Bore size (mm)	32	40	50	63	80	100
Action	Double acting					
Fluid	Air					
Proof pressure	1.5 MPa					
Max. operating pressure	1.0 MPa					
Min. operating pressure	0.05 MPa					
Ambient and fluid temperature	Without auto switch: -10 to 70°C (No freezing) With auto switch: -10 to 60°C (No freezing)					
Lubrication	Not required (Non-lube)					
Operating piston speed	50 to 1000 mm/s					
Allowable stroke tolerance	Up to 250: ^{+1.0} ₀ , 251 to 1000: ^{+1.4} ₀ , 1001 to 1500: ^{+1.8} ₀					
Cushion ^{Note)}	Both ends (Air cushion)					
Thread tolerance	JIS Class 2					
Port size	G 1/8	G 1/4	G 1/4	G 3/8	G 3/8	G 1/2
Mounting	Basic style, Axial foot style, Rod side flange style, Head side flange style, Single clevis style, Double clevis style					
Non-rotating accuracy	ø32, ø40	±0.5°				
	ø50, ø63	±0.5°				
	ø80, ø100	±0.3°				
Allowable rotating torque (N·m) max.	ø32	0.25	ø80		0.79	
	ø40	0.45	ø100		0.93	
	ø50, ø63	0.64	—		—	

Note) Absorbable kinetic energy by cushion mechanism is identical to double acting single rod.

Accessory

Mounting		Basic style	Foot style	Rod side frange style	Head side frange style	Single clevis style	Double clevis style
Standard	Rod end nut	●	●	●	●	●	●
	Clevis pin	—	—	—	—	—	●
Option	Single rod clevis	●	●	●	●	●	●
	Double rod clevis (With pin)	●	●	●	●	●	●
	Rod boot	●	●	●	●	●	●

Weight/Aluminum Tube

Bore size (mm)		32	40	50	63	80	100
Basic weight	Basic style	0.59	0.87	1.44	2.00	3.37	4.45
	Axial foot style	0.16	0.20	0.38	0.46	0.89	1.09
	Flange style	0.20	0.23	0.47	0.58	1.30	1.81
	Single clevis style	0.16	0.23	0.37	0.60	1.07	1.73
	Double clevis style	0.20	0.32	0.45	0.71	1.28	2.11
Additional weight per each 50 mm of stroke	All mounting brackets	0.11	0.16	0.26	0.27	0.42	0.56
Accessory	Single rod clevis	0.07	0.11	0.22	0.22	0.40	0.40
	Double clevis (With pin)	0.09	0.15	0.34	0.34	0.69	0.69

Calculation: (Example) CP95KD40-100

- Basic weight 0.87 (kg) (Basic)
- Additional weight ... 0.16 (kg/50 st)
- Cylinder stroke 100 (st)
- Mounting 0.32 (kg) (Double clevis)

$$0.87 + 0.16 \times 100 \div 50 + 0.32 = 1.51 \text{ kg}$$

CJ1

CJP

CJ2

CM2

CG1

MB

MB1

CA2

CS1

C76

C85

C95

CP95

NCM

NCA

D-

-X

20-

Data

Series CP95K

Standard Stroke

Bore size (mm)	Standard stroke (mm)
32	25, 50, 80, 100, 125, 160, 200, 250, 320, 400, 500
40	25, 50, 80, 100, 125, 160, 200, 250, 320, 400, 500
50	25, 50, 80, 100, 125, 160, 200, 250, 320, 400, 500, 600
63	25, 50, 80, 100, 125, 160, 200, 250, 320, 400, 500, 600
80	25, 50, 80, 100, 125, 160, 200, 250, 320, 400, 500, 600, 700, 800
100	25, 50, 80, 100, 125, 160, 200, 250, 320, 400, 500, 600, 700, 800

Intermediate strokes are available.

Minimum Stroke for Auto Switch Mounting

Refer to page 6-13-19 on "Minimum Strokes for Auto Switch Mounting".

Theoretical Output

OUT side is identical to double acting single rod. Refer to table below for IN side.

Bore size (mm)	Piston area (mm ²)	Bore size (mm)	Piston area (mm ²)
32	675	63	2804
40	1082	80	4568
50	1651	100	7223

Theoretical output (N) =
Pressure (MPa) x Piston area (mm²)

Construction

[First angle projection]

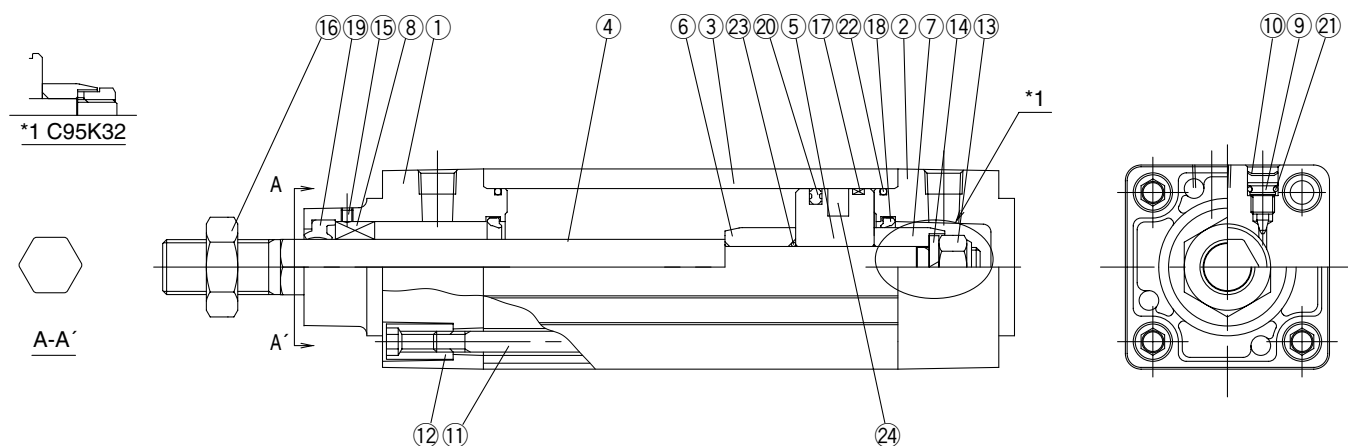

Component Parts

No.	Description	Material
①	Rod cover	Aluminum die-casted
②	Head cover	Aluminum die-casted
③	Cylinder tube	Aluminum alloy
④	Piston rod	Stainless steel
⑤	Piston	Aluminum alloy
⑥	Cushion ring A	Rolled steel
⑦	Cushion ring B	Rolled steel
⑧	Bushing	Oil impregnated sintered alloy
⑨	Cushion valve	Steel
⑩	Snap ring	Steel for spring
⑪	Tie-rod	Carbon Steel
⑫	Tie-rod nut	Steel
⑬	Piston nut	Steel

No.	Description	Material
⑭	Spring washer	Steel wire
⑮	Set screw	Chrome-molybdenum steel
⑯	Rod end nut	Steel
⑰	Wear ring	Resin
⑱	Cushion seal	Urethan rubber
⑲	Rod seal	NBR
⑳	Piston seal	NBR
㉑	Cushion valve seal	NBR
㉒	Cylinder tube gasket	NBR
㉓	Piston gasket	NBR
㉔	Magnet	

Replacement Parts: Seal Kit

Bore size (mm)	Kit no.	Contents
32	CK95-32	Kits include items ⑰ to ㉑ and ㉒.
40	CK95-40	
50	CK95-50	
63	CK95-63	
80	CK95-80	
100	CK95-100	

* Seal kits consist of items ⑰ to ㉑ and ㉒ contained in one kit, and can be ordered using the order number for each respective tube bore size.

ISO/VDMA Cylinder: Non-rotating Type Double Acting w/ End of Stroke Cushioning **Series CP95K**

Dimensions: Non-rotating Rod Specifications

[First angle projection]

CP95K□B Bore size Stroke

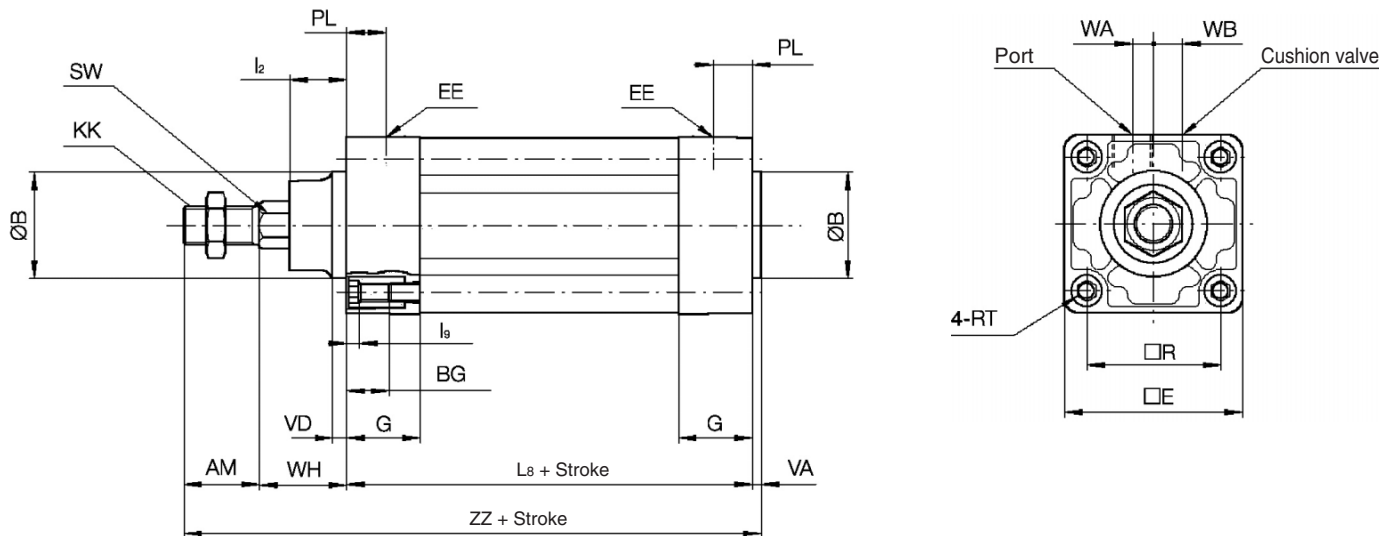

CP95K□B Bore size Stroke W

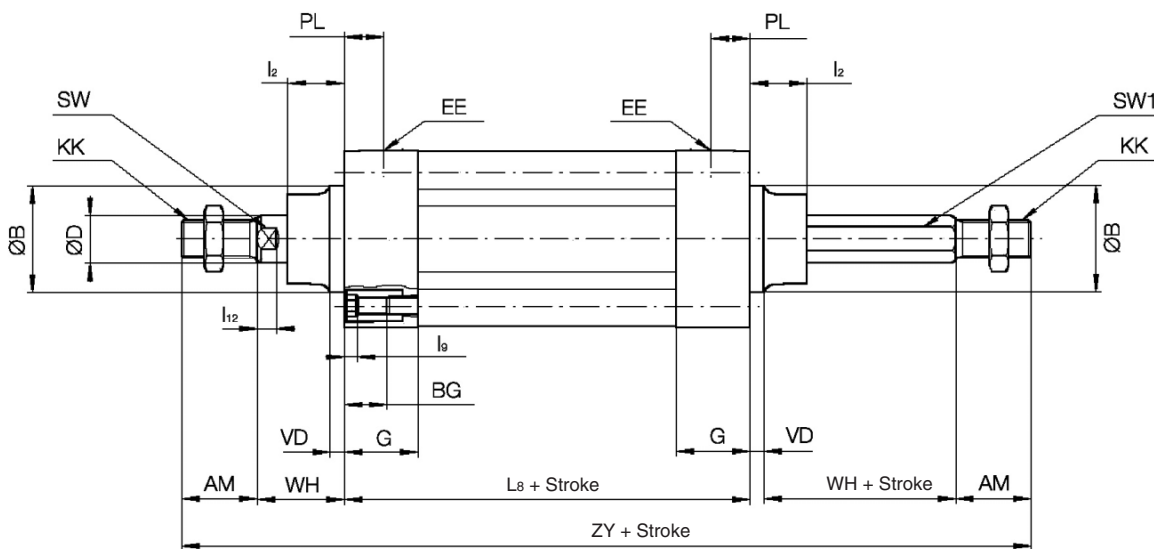

- CJ1
- CJP
- CJ2
- CM2
- CG1
- MB
- MB1
- CA2
- CS1
- C76
- C85
- C95
- CP95**
- NCM
- NCA
- D-
- X
- 20-
- Data

Bore size (mm)	AM	øB	øD	EE	PL	RT	l ₁₂	KK	SW	G	BG (MIN)	L ₈	VD	VA	WA	WB	WH	ZZ	ZY	□E	□R	l ₂	l ₉
32	22	30	12	G 1/8	13	M6 x 1.0	6	M10 x 1.25	10	27	16	94	4	4	4	6.5	26	146	190	46	32.5	15	4
40	24	35	16	G 1/4	14	M6 x 1.0	6.5	M12 x 1.25	13	27	16	105	4	4	4	9	30	163	213	52	38	17	4
50	32	40	20	G 1/4	15.5	M8 x 1.25	8	M16 x 1.5	16	31.5	16	106	6	4	5	10.5	37	179	244	65	46.5	24	5
63	32	45	20	G 3/8	16.5	M8 x 1.25	8	M16 x 1.5	16	31.5	16	121	6	4	9	12	37	194	259	75	56.5	24	5
80	40	45	25	G 3/8	19	M10 x 1.5	10	M20 x 1.5	21	38	16	128	8	4	11.5	14	46	218	300	95	72	30	5
100	40	55	30	G 1/2	19	M10 x 1.5	10	M20 x 1.5	21	38	16	138	8	4	17	15	51	233	320	114	89	32	5

Series CP95K

Dimensions: Cylinder Mounting Accessory L, F, G, C and D

[First angle projection]

Mounting style (L)

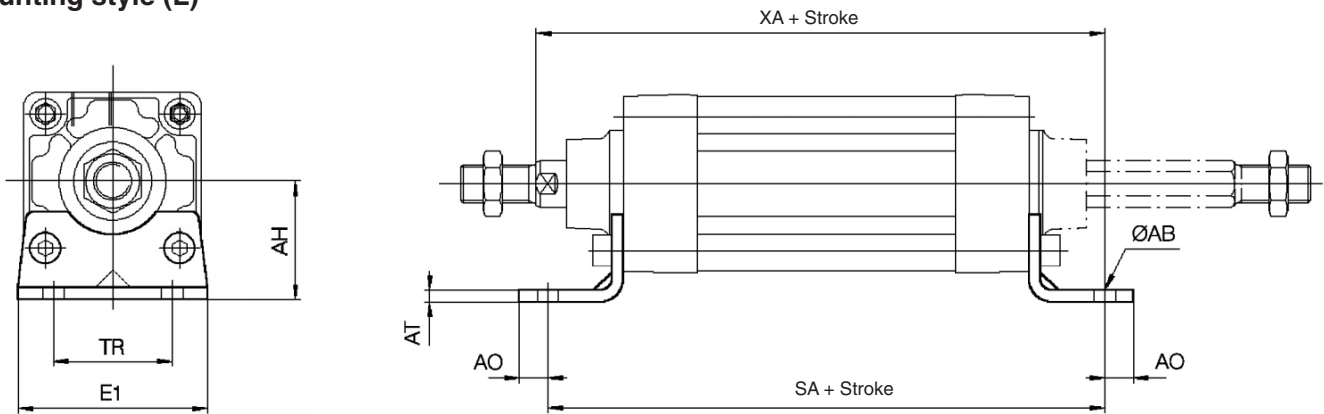

Mounting style (F, G)

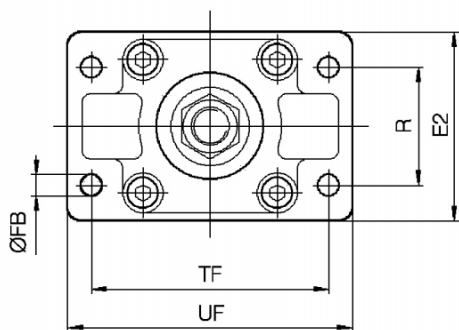

Head side mounting (G)

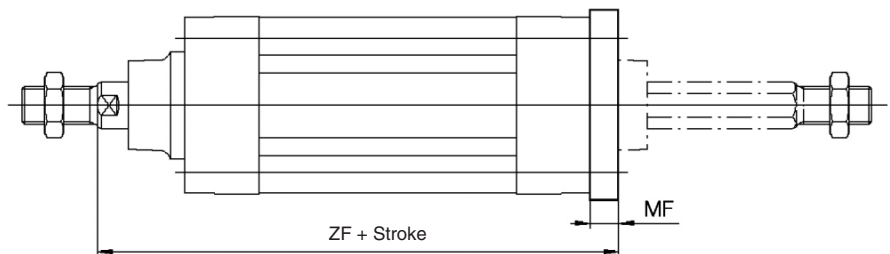

Rod side mounting (F)

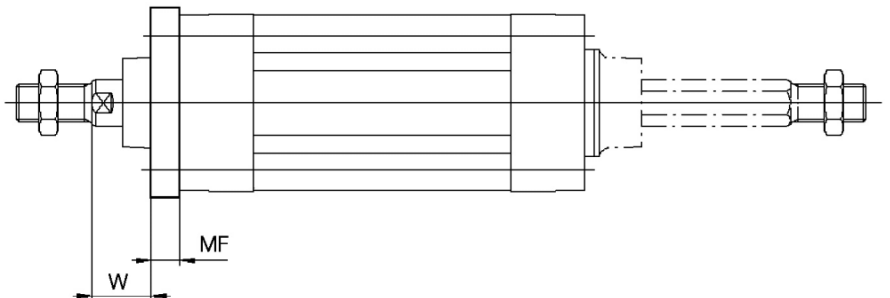

Mounting style (C)

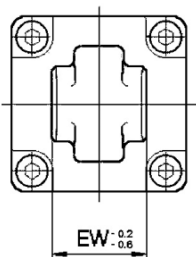

Mounting style (D)

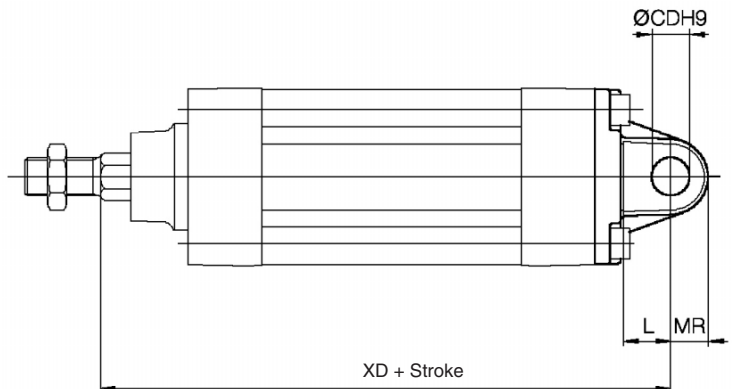
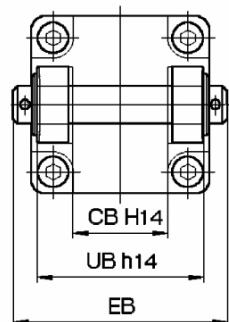

Bore size (mm)	E1	R	W	MF	ZF	øFB	CD	EB	L	XD	UB	CB	EW	MR	TR	AO	AT	XA	SA	AH	øAB	TF	UF	E2
32	48	32	16	10	130	7	10	65	12	142	45	26	26	9.5	32	10	4.5	144	142	32	7	64	79	50
40	55	36	20	10	145	9	12	75	15	160	52	28	28	12	36	11	4.5	163	161	36	10	72	90	55
50	68	45	25	12	155	9	12	80	15	170	60	32	32	12	45	12	5.5	175	170	45	10	90	110	70
63	80	50	25	12	170	9	16	90	20	190	70	40	40	16	50	12	5.5	190	185	50	10	100	120	80
80	100	63	30	16	190	12	16	110	20	210	90	50	50	16	63	14	6.5	215	210	63	12	126	153	100
100	120	75	35	16	205	14	20	140	25	230	110	60	60	20	75	16	6.5	230	220	71	14.5	150	178	120

ISO/VDMA Cylinder: Non rotating Type Double Acting w/ End of Stroke Cushioning **Series CP95**

Minimum Stroke for Auto Switch



Type	Auto switch model	No. of auto switches mounted *	ø32	ø40	ø50	ø63	ø80	ø100
Reed switch	D-Z73L	2 pcs.	25				15	
	D-Z80L	1 pcs.						
Solid state switch	D-Y59BL	2 pcs.	25				15	
	D-Y69BL	1 pcs.						
	D-Y7PL							

* Auto switches are mounted on the same side but in different grooves of the cylinder.

Recommended Mounting Position for Stroke Ends

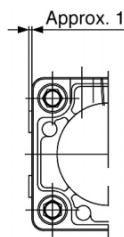
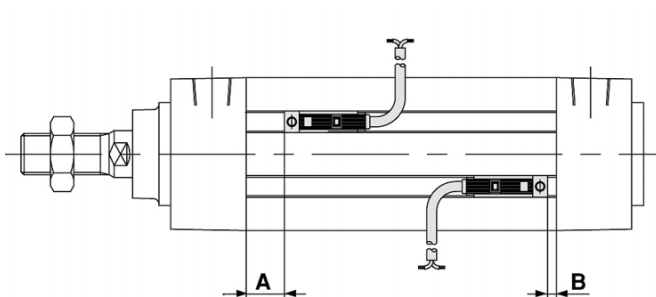

Bore size (mm)	D-Z73L, D-Z80L, D-Y7PL D-Y59BL, D-Y69BL	
	A	B
32	14	1
40	25	1
50	16	2
63	31	2
80	21.5	5.5
100	31.5	5.5

Mounting of Auto Switch

When attaching an auto switch, first take a switch holder between your fingers and press it into a switch mounting groove. When doing this, confirm that it is set in the correct mounting orientation, or reattach if necessary. Next, insert an auto switch into the groove and slide it until it is positioned under the switch holder. After establishing the mounting position, use a watchmakers flat head screwdriver to tighten the switch mounting screw which is included.

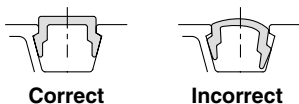

Switch holder: BMP1-032

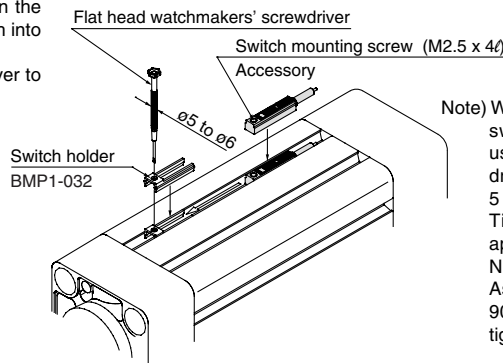

How to Order Auto Switch, Holder and Groove Cover

Auto Switch Holder Band

Bore size (mm)	Part no.	
	Auto switch	Switch holder
32	D-Z73L	BMP1-032
40	D-Z80L	
50	D-Y7PL	
63	D-Y59BL	
80	D-Y69BL	
100		

Groove Cover of Square Tube

Bore size (mm)	Part no.	Cylinder length without stroke
32	CP95-AL □	41.5 mm
40		52.5 mm
50		44.5 mm
63		59.5 mm
80		53.5 mm
100		63.5 mm

□ Write the required length of the groove cover in the box.

Groove covers are available in progressive rates of 1 meter. Please indicate round figures when ordering.

Order example: Groove cover for CP95SB63-160
 59.5 mm + 160 mm = 239.5 x 8 grooves = 1916 mm
 [Cylinder length without stroke] [Stroke] [8 grooves in the square tube]

Length to order: 1916 mm corresponds to a groove cover of 2 m for each cylinder
 Order no.: **CP95-AL (2) length in meters**

- CJ1
- CJP
- CJ2
- CM2
- CG1
- MB
- MB1
- CA2
- CS1
- C76
- C85
- C95
- CP95
- NCM
- NCA
- D-
- X
- 20-
- Data