

Series CQS

Compact Cylinder

Compact Type $\varnothing 12$, $\varnothing 16$, $\varnothing 20$, $\varnothing 25$





Compact Cylinder

Series CQS

ø12, ø16, ø20, ø25



■ Available with inch or metric threads for increased design flexibility

■ Ideal for machine designs with small space requirements

The "D-A9□" and "D-M9□" auto switches will not protrude from switch mounting groove.

■ Auto switch mounting available on up to four surfaces

3 faces on ø12 & ø16, and all 4 faces including port side on ø20, ø25.

■ 2 way basic mounting: Through-hole and both ends tapped mounting are combined

■ Non-rotating piston rod model with superior non-rotating accuracy

ø12, ø16 — ± 1°
ø25, ø25 — ± 0.7°

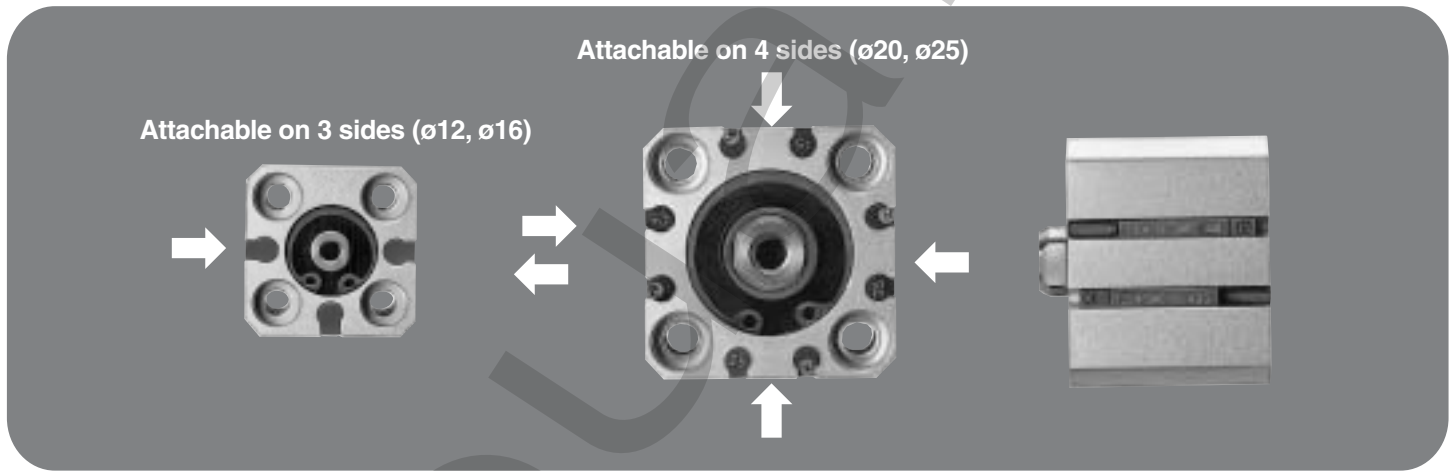

Variations

	Basic model	Variations (Standard)	Applicable auto switch	Bore size (mm)	Stroke (mm)	Page
Basic	Series CQS	Double Acting	Reed switch D-A90, A90V D-A93, A93V D-A96, A96V	12, 16 20, 25	Standard stroke ø12 } 5, 10, 15, 20, 25, 30 ø16 } 5, 10, 15, 20 ø20 } 25, 30, 35, 40, 45, 50 ø25 }	How to Order 1 Accessories 5
	Series CQSW	Double Rod			Long stroke ø12 } 35, 40, 45, 50, 75, 100 ø16 } 75, 100, 125, 150 ø20 } 175, 200 ø25 } 75, 100, 125, 150 175, 200, 250, 300	How to Order 1 Construction 6 Dimensions 7 & 8
Non-rotating Rod	Series CQS	Single Acting	Solid state switch D-M9N, F9NV D-M9P, F9PV D-M9B, F9BV D-F9NW, F9NWW D-F9PW, F9PWW D-F9BW, F9BWW	12, 16 20, 25	ø12 } 5, 10 ø16 } ø20 } ø25 }	How to Order 1 Construction 12 Dimensions ...13 to 16
	Series CQSK	Double Acting			ø12 } 5, 10, 15, 20, 25, 30 ø16 } ø20 } 5, 10, 15, 20, 25, 30 ø25 } 35, 40, 45, 50	How to Order 1 Construction 17 Dimensions ...18 & 19

* Non-rotating rod/Double acting double rod can be made.

Note 1) Standard equipment on long stroke model

- Built-in magnet
- Rod end male thread
- Rubber bumper
- Foot/Flange mounting
- Double clevis mounting

How to Order

Standard CQS **K** **B** **20** **NN** **30** **D** **□**

With auto switch CDQS **K** **B** **20** **NN** **30** **D** **□** **A90** **S**

Model

Nil	Single/Double acting, Single rod
W	Double acting, Double rod
K	Double acting, Single rod, Non-rotating

Bore size

12	12mm
16	16mm
20	20mm
25	25mm

Thread option

Nil	Metric threads
NN	Inch threads

Auto switch

Nil	Without auto switch (Built-in magnet)
-----	---------------------------------------

Number of auto switches

Nil	2
S	1
n	n

Mounting style

B	Through-hole/Both ends tapped (Standard)
L	Foot
F	Front flange
G	Rear flange (Note 1)
D	Double clevis (Note 1)

Action

D	Double acting
S	Single acting spring return (Note 1)
T	Single acting spring extend (Note 1)

Option <Standard stroke>

Nil	No option
C	Rubber bumper (Note 1)
M	Rod end male thread

Option <Long stroke>

C	Rubber bumper (Standard equipment for long stroke model)
CM	Rubber bumper & Rod end male thread

Note 1) Not available for with Double rod or Non-rotating rod.

Cylinder stroke (mm)

Bore size (mm)	Double acting, Single rod		Single acting, Single rod	Double acting, Double rod	Double acting, Single rod Non-rotating
	Standard stroke (mm)	Long stroke (mm)	Standard (mm)	Standard (mm)	Standard (mm)
12, 16	5, 10, 15, 20, 25, 30	35, 40, 45, 50, 75, 100	5, 10	5, 10, 15, 20, 25, 30	
20	5, 10, 15, 20, 25, 30, 35, 40, 45, 50	75, 100, 125, 150, 175, 200		5, 10, 15, 20, 25, 30, 35, 40, 45, 50	
25		75, 100, 125, 150, 175, 200, 250, 300			

Mounting Bracket Part No.

Bore size (mm)	Metric		
	Foot (Note 1)	Flange	Double clevis
12	CQS-L012	CQS-F012	CQS-D012
16	CQS-L016	CQS-F016	CQS-D016
20	CQS-L020	CQS-F020	CQS-D020
25	CQS-L025	CQS-F025	CQS-D025

Bore size (mm)	Inch		
	Foot (Note 1)	Flange	Double clevis
12	NCQS-L012	NCQS-F012	NCQS-D012
16	NCQS-L016	NCQS-F016	NCQS-D016
20	NCQS-L020	NCQS-F020	NCQS-D020
25	NCQS-L025	NCQS-F025	NCQS-D025

Note 1) 2 pieces per cylinder should be ordered.
 • Each package contains the following parts.
 Foot or Flange style : Body mounting bolt
 Double clevis style : Clevis pin, snap ring retainer, body mounting bolt.

For K Type

Bore size (mm)	Metric	
	Foot (Note 1)	Flange
12	CQSK-L012	CQSK-F012
16	CQSK-L016	CQSK-F016
20	CQSK-L020	CQSK-F020
25	CQSK-L025	CQSK-F025

Bore size (mm)	Inch	
	Foot (Note 1)	Flange
12	NCQSK-L012	NCQSK-F012
16	NCQSK-L016	NCQSK-F016
20	NCQSK-L020	NCQSK-F020
25	NCQSK-L025	NCQSK-F025

Applicable Auto Switches

Style	Special function	Electrical entry	Indicator	Wiring (Output)	Load voltage			Auto switch model		Lead wire (m)*			Applicable load	
					DC	AC		Perpendicular	In-line	0.5 (—)	3 (L)	5 (Z)	IC	Relay PLC
						5V 12V 100V or less	12V 100V							
Reed switch	—	Grommet	No	2 wire	24V	5V 12V 100V or less	—	A90V	A90	●	●	—	IC	Relay PLC
								A93V	A93	●	●	—		
Reed switch	—	Grommet	Yes	3 wire (Equiv. NPN)	—	5V	—	A96V	A96	●	●	—	IC	—
Solid state switch	Diagnostic indication (2 color)	Grommet	Yes	3 wire (NPN)	24V	12V	—	F9NV	M9N	●	●	—	—	Relay PLC
								F9PV	M9P	●	●	—		
								F9BV	M9B	●	●	—		
								F9NWV	F9NW	●	●	○		
								F9PWV	F9PW	●	●	○		
								F9BWV	F9BW	●	●	○		
				2 wire				F9BA	—	●	○			

* ○ : Manufactured upon receipt of order. * Lead wire length 0.5m — (Example) A93
 3m L (Example) A93L
 5m Z (Example) F9NWZ

Series CQS

Compact Cylinder



Specifications

Style	Pneumatic (Non-lube)
Fluid	Air
Proof pressure	1.5MPa (217.5 psi)
Max. operating pressure	1.0MPa (145.0 psi)
Ambient & fluid temperature	Without auto switch -10°C (14°F) to 70°C (158°F) (No freezing) With auto switch -10°C (14°F) to 60°C (140°F) (No freezing)
Rubber bumper	Standard stroke: None; Long stroke: Standard equipment
Rod end thread	Female
Rod end thread tolerance	JIS class 2
Stroke length tolerance	Standard stroke: $^{+1.0}_0$ mm Long stroke: $^{+1.4}_0$ mm
Basic mounting	Through-hole/Both ends tapped
Operating piston speed	50 to 500mm/s (2 to 20in/s)

Minimum Strokes for Auto Switch Mounting

Unit: mm

No. of auto switches	D-A9□, D-F9□WV	D-A9□V	D-M9N	D-M9□, D-F9□W	D-F9□V	D-F9BA
2	10	10	15*	20*	5	25*
1	10*	5	15*	20*	5	25*

* Consult P/A for shorter stroke lengths than indicated in the table.

Allowable Kinetic Energy

Bore size (mm)	12		16		20		25	
	J	lbf-ft	J	lbf-ft	J	lbf-ft	J	lbf-ft
Standard	0.022	0.016	0.038	0.028	0.055	0.041	0.090	0.066
With rubber bumper	0.043	0.032	0.075	0.055	0.110	0.081	0.180	0.133

Minimum Operating Pressure

Bore size (mm)	12/16		20/25	
	MPa	psi	MPa	psi
Min. operating pressure	0.07	10.2	0.05	7.3

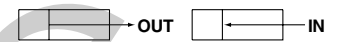

Double Acting Single or Double Rod — Theoretical Force

Bore size	Rod diameter		Operation	Piston area		Operating pressure					
				(mm ²)	(in ²)	MPa	psi	MPa	psi	MPa	psi
						0.3	43.5	0.5	72.5	0.7	101.5
						Theoretical Force					
(mm)	(inch)			N	lbf	N	lbf	N	lbf		
12	6	0.24	IN	84.8	0.131	25	5.6	42	9.4	59	13.3
			OUT	113	0.175	34	7.6	57	12.8	79	17.8
16	8	0.31	IN	151	0.234	45	10.1	75	16.9	106	23.8
			OUT	201	0.312	60	13.5	101	22.7	141	31.7
20	10	0.39	IN	236	0.366	71	16.0	118	26.5	165	37.1
			OUT	314	0.487	94	21.1	157	35.3	220	49.5
25	12	0.47	IN	378	0.586	113	25.4	189	42.5	264	59.3
			OUT	491	0.761	147	33.0	245	55.1	344	77.3

Note) In case of double rod, use value of "IN" for both extend and retract.

Double Acting Single Rod Non-rotating Rod — Theoretical Force

Bore size	Rod width across flats		Operation	Piston area		Operating pressure					
				(mm ²)	(in ²)	MPa	psi	MPa	psi	MPa	psi
						0.3	43.5	0.5	72.5	0.7	101.5
						Theoretical Force					
(mm)	(inch)			N	lbf	N	lbf	N	lbf		
12	5.2	0.20	IN	90	0.140	27	6.1	45	10.1	63	14.2
			OUT	113	0.175	34	7.6	57	12.8	79	17.8
16	6.2	0.24	IN	168	0.260	50	11.2	84	18.9	117	26.3
			OUT	201	0.312	60	13.5	101	22.7	141	31.7
20	8.2	0.32	IN	256	0.397	77	17.3	128	28.8	179	40.2
			OUT	314	0.487	94	21.1	157	35.3	220	49.5
25	10.2	0.40	IN	401	0.622	120	27.0	200	45.0	281	63.2
			OUT	491	0.761	147	33.0	245	55.1	344	77.3

Single Acting Single Rod Spring Extend/Return — Theoretical Force

Action	Bore size	Rod diameter		Operation	Piston area		Operating pressure						Spring force			
					(mm ²)	(in ²)	MPa	psi	MPa	psi	MPa	psi				
							0.3	43.5	0.5	72.5	0.7	101.5				
							Theoretical Force						Compressed		At rest	
(mm)	(inch)			N	lbf	N	lbf	N	lbf	N	lbf					
Spring return	12	6	0.24	IN	—	—	—	—	—	—	—	14	3.1	4	0.9	
				OUT	113	0.175	20	4.5	43	9.7	65					14.6
	16	8	0.31	IN	—	—	—	—	—	—	—	15	3.4	6	1.3	
				OUT	201	0.312	45	10.1	86	19.3	126					28.3
	20	10	0.39	IN	—	—	—	—	—	—	—	15	3.4	6	1.3	
				OUT	314	0.487	78	17.5	141	31.7	204					45.9
25	12	0.47	IN	—	—	—	—	—	—	—	21	4.7	11	2.5		
			OUT	491	0.761	126	28.3	224	50.4	323					72.6	
Spring extend	12	6	0.24	IN	84.8	0.131	14	3.1	31	7.0	48	10.8	10	2.2	3	0.7
				OUT	—	—	—	—	—	—	—	—				
	16	8	0.31	IN	151	0.234	24	5.4	54	12.1	85	19.1	19	4.3	4	0.9
				OUT	—	—	—	—	—	—	—	—				
	20	10	0.39	IN	236	0.366	44	9.9	91	20.5	138	31.0	27	6.1	5	1.1
				OUT	—	—	—	—	—	—	—	—				
25	12	0.47	IN	378	0.586	84	18.9	160	36.0	235	52.8	29	6.5	10	2.2	
			OUT	—	—	—	—	—	—	—	—					

Series CQS

Compact Cylinder

Weights

Stroke (mm)		5	10	15	20	25	30	35	40	45	50	75	100	125	150	175	200	250	300	
Double acting single rod without auto switch	12	g	29	36	42	49	56	63	93	100	107	113	147	180	—	—	—	—	—	—
		oz	1.02	1.27	1.48	1.73	1.98	2.22	3.28	3.53	3.77	3.99	5.19	6.35	—	—	—	—	—	—
	16	g	38	47	56	64	73	82	119	128	136	145	187	229	—	—	—	—	—	—
		oz	1.34	1.66	1.98	2.26	2.57	2.89	4.20	4.52	4.80	5.11	6.60	8.08	—	—	—	—	—	—
	20	g	63	75	88	101	114	127	140	153	166	178	306	370	434	498	562	627	—	—
		oz	2.22	2.65	3.10	3.56	4.02	4.48	4.94	5.40	5.86	6.28	10.79	13.05	15.31	17.57	19.82	22.12	—	—
	25	g	91	107	123	139	155	171	186	202	218	234	399	478	557	636	715	794	952	1110
		oz	3.21	3.77	4.34	4.90	5.47	6.03	6.56	7.13	7.69	8.25	14.07	16.86	19.65	22.43	25.22	28.01	33.58	39.15
Double acting single rod with auto switch	12	g	37	43	50	57	63	70	94	101	108	114	148	181	—	—	—	—	—	—
		oz	1.31	1.52	1.76	2.01	2.22	2.47	3.32	3.56	3.81	4.02	5.22	6.38	—	—	—	—	—	—
	16	g	48	57	66	74	83	92	121	129	137	146	188	231	—	—	—	—	—	—
		oz	1.69	2.01	2.33	2.61	2.93	3.25	4.27	4.55	4.83	5.15	6.63	8.15	—	—	—	—	—	—
	20	g	93	106	119	132	144	157	170	182	195	208	311	375	439	503	567	632	—	—
		oz	3.28	3.74	4.20	4.66	5.08	5.54	6.00	6.42	6.88	7.34	10.97	13.23	15.49	17.74	20.00	22.29	—	—
	25	g	134	150	166	182	197	213	229	245	261	277	406	485	564	643	721	800	958	1116
		oz	4.73	5.29	5.86	6.42	6.95	7.51	8.08	8.64	9.21	9.77	14.32	17.11	19.89	22.68	25.43	28.22	33.79	39.37

		Stroke (mm)										
		5	10	15	20	25	30	35	40	45	50	
Double acting double rod without auto switch	12	g	38	46	54	62	69	77	—	—	—	—
		oz	1.34	1.62	1.90	2.19	2.43	2.72	—	—	—	—
	16	g	50	61	71	81	92	102	—	—	—	—
		oz	1.76	2.15	2.50	2.86	3.25	3.60	—	—	—	—
	20	g	89	104	120	136	152	167	183	199	215	231
		oz	3.14	3.67	4.23	4.80	5.36	5.89	6.46	7.02	7.58	8.15
	25	g	127	146	166	186	206	227	247	267	287	308
		oz	4.48	5.15	5.86	6.56	7.27	8.01	8.71	9.42	10.12	10.86
Double acting double rod with auto switch	12	g	46	54	62	70	77	85	—	—	—	—
		oz	1.62	1.90	2.19	2.47	2.72	3.00	—	—	—	—
	16	g	60	71	81	91	102	112	—	—	—	—
		oz	2.12	2.50	2.86	3.21	3.06	3.95	—	—	—	—
	20	g	119	134	150	166	182	198	214	230	245	261
		oz	4.20	4.73	5.29	5.86	6.42	6.98	7.55	8.11	8.64	9.21
	25	g	154	174	195	215	235	255	276	296	316	336
		oz	5.43	6.14	6.88	7.58	8.29	8.99	9.74	10.44	11.15	11.85

		Stroke (mm)		
		5	10	
Single acting spring return without auto switch	12	g	29	36
		oz	1.02	1.27
	16	g	39	48
		oz	1.38	1.69
	20	g	63	76
		oz	2.22	2.68
	25	g	92	108
		oz	3.25	3.81
Single acting spring return with auto switch	12	g	37	44
		oz	1.31	1.55
	16	g	49	58
		oz	1.73	2.05
	20	g	94	107
		oz	3.32	3.77
	25	g	130	146
		oz	4.59	5.15

		Stroke (mm)		
		5	10	
Single acting spring extend without auto switch	12	g	31	37
		oz	1.09	1.31
	16	g	39	47
		oz	1.38	1.66
	20	g	68	79
		oz	2.40	2.79
25	g	98	113	
	oz	3.46	3.99	
Single acting spring extend with auto switch	12	g	39	45
		oz	1.38	1.59
	16	g	51	59
		oz	1.80	2.08
	20	g	104	115
		oz	3.67	4.06
25	g	150	165	
	oz	5.29	5.82	

Option Weights Note 1)

Option		12		16		20		25	
		g	oz	g	oz	g	oz	g	oz
Rod end thread <small>Note 2)</small>	Male thread	1.5	0.05	3	0.11	6	0.21	12	0.42
	Nut	1	0.04	2	0.07	4	0.14	8	0.28
Rubber bumper <small>Note 3)</small>	Single rod	0	0	1	0.04	-2	-0.07	-3	-0.11
	Double rod	0	0	-1	-0.04	-2	-0.07	-2	-0.07
Foot (including bolt)	Standard	55	1.94	65	2.29	159	5.61	181	6.38
	Long stroke	53	1.87	61	2.15	153	5.40	172	6.07
Front flange (including bolt)	Standard	58	2.05	70	2.47	143	5.04	180	6.35
	Long stroke	56	1.98	66	2.33	137	4.83	171	6.03
Rear flange (including bolt)		56	1.98	66	2.33	137	4.83	171	6.03
Double clevis (including pin, retainer, bolt)		34	1.20	40	1.14	92	3.25	127	4.48

Standard stroke model

- Calculation Example) CQSD20NN-20DCM
- Cylinder weight: CQSB20NN-20D 101g
 - Option weight : Rod end male thread 10g
 - : Rubber bumper -2g
 - : Double clevis 92g

Total 201g

Note 1) Values are the same for all models except where indicated.
 Note 2) In case of Double rod, multiply value by 2.

Note 3) Do not add value to long stroke models.

Accessories

Single knuckle joint

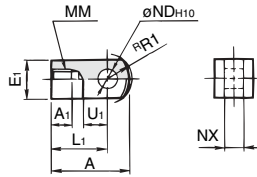

Metric Threads

Part No.	Bore size (mm)	A	A ₁	E ₁	L ₁	MM	^R R ₁	U ₁	ND _{H10}	NX
I-G012	12	21.5	6	□10	16	M5 x 0.8	6.3	7	5 ^{+0.048} ₀	5 ^{-0.2} _{-0.4}
I-Z015A	16	32	8	□12	25	M6 x 1	8.1	14	5 ^{+0.048} ₀	6.4 ^{-0.1} _{-0.3}
I-G02	20	34	8.5	□16	25	M8 x 1.25	10.3	11.5	8 ^{+0.058} ₀	8 ^{-0.2} _{-0.4}
I-G03	25	41	10.5	□20	30	M10 x 1.25	12.8	14	10 ^{+0.058} ₀	10 ^{-0.2} _{-0.4}

Inch Threads

Part No.	Bore size (mm)	A	A ₁	E ₁	L ₁	MM	^R R ₁	U ₁	ND _{H10} (inch)	NX
RCS-01	12	21.5	6	□10	16	#8-32UNC	6.3	7	3/16 ^{+0.002} ₀	5 ^{-0.2} _{-0.4}
RCS-015	16	32	6	□12	25	#8-32UNC	12	14	3/16 ^{+0.002} ₀	6.4 ^{-0.1} _{-0.3}
RCS-02	20	34	6	□16	25	#10-32UNF	10.3	11.5	5/16 ^{+0.002} ₀	8 ^{-0.2} _{-0.4}
RCS-025	25	41	8	□20	30	1/4-28UNF	18	14	3/8 ^{+0.002} ₀	10 ^{-0.2} _{-0.4}

Knuckle pin (Common with double clevis pin)

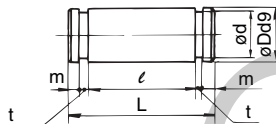

Metric Threads

Part No.	Bore size (mm)	Dd9	L	d	ℓ	m	t	Snap ring
IY-G012	12	5 ^{-0.030} _{-0.060}	14.6	4.8	10.2	1.5	0.7	Axial C style 5
IY-J015	16	5 ^{-0.030} _{-0.060}	16.6	4.8	12.2	1.5	0.7	Axial C style 5
IY-G02	20	8 ^{-0.040} _{-0.076}	21	7.6	16.2	1.5	0.9	Axial C style 8
IY-G03	25	10 ^{-0.040} _{-0.076}	25.6	9.6	20.2	1.55	1.15	Axial C style 10

Inch Threads

Part No.	Bore size (mm)	Dd9 (inch)	L	d	ℓ	m	t
PS-01	12	3/16 ^{+0.002} ₀	14	4.45	10.2	1.44	0.46
PS-015	16	3/16 ^{+0.002} ₀	16	4.45	12.2	1.44	0.46
PS-02	20	5/16 ^{+0.002} ₀	21	7.37	16.2	1.66	0.74
PS-025	25	3/8 ^{+0.002} ₀	25	8.94	20.2	1.66	0.74

Double knuckle joint

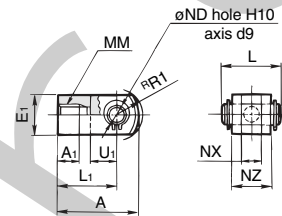

Metric Threads

Part No.	Bore size (mm)	A	A ₁	E ₁	L ₁	MM	^R R ₁	U ₁	ND _{H10}	NX	NZ	L	Pin part No.
Y-G012	12	21.5	6	□10	16	M5 x 0.8	6.3	7	5 ^{+0.048} ₀	5 ^{-0.4} _{-0.2}	10	14.6	IY-G012
Y-Z015A	16	28	11	□12	21	M6 x 1	8.1	10	5 ^{+0.048} ₀	6.5 ^{-0.2} ₀	12	16.6	IY-J015
Y-G02	20	34	8.5	□16	25	M8 x 1.25	10.3	11.5	8 ^{+0.058} ₀	8 ^{-0.4} _{-0.2}	16	21	IY-G02
Y-G03	25	41	10.5	□20	30	M10 x 1.25	12.8	14	10 ^{+0.058} ₀	10 ^{-0.4} _{-0.2}	20	25.6	IY-G03

Inch Threads

Part No.	Bore size (mm)	A	A ₁	E ₁	L ₁	MM	^R R ₁	U ₁	ND _{H10}	NX	NZ	L
RCD-01	12	21.5	6	□10	16	#8-32UNC	6.3	7	3/16 ^{+0.002} ₀	5 ^{-0.4} _{-0.2}	10	14.6
RCD-015	16	28	6	□12	21	#8-32UNC	12	10	3/16 ^{+0.002} ₀	6.5 ^{+0.2} ₊₀	12	16.6
RCD-02	20	34	6	□16	25	#10-32UNF	10.3	11.5	5/16 ^{+0.002} ₀	8 ^{-0.2} _{-0.4}	16	21
RCD-025	25	41	8	□20	30	1/4-28UNF	18	14	3/8 ^{+0.002} ₀	10 ^{-0.2} _{-0.4}	20	25.6

* Knuckle pin and snap ring are contained.

Rod end nut

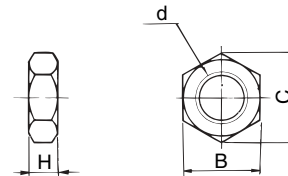

Metric Threads

Part No.	Bore size (mm)	d	H	B	C
NTJ-015A	12	M5 x 0.8	4	8	9.2
NT-015A	16	M6 x 1	5	10	11.5
NT-02	20	M8 x 1.25	5	13	15.0
NT-03	25	M10 x 1.25	6	17	19.6

Inch Threads

Part No.	Bore size (mm)	d	H	B	C
JM-01	12, 16	#8-32UNC	3.3	8.7	10
JM-02	20	#10-32UNF	3.3	9.5	11
JM-025	25	1/4-28UNF	4.1	11.2	13

• Note on dimensions: Except where indicated, metric (mm) dimensions are shown. 1inch = 25.4mm

Series CQS

Compact Cylinder

Construction — Double Acting Single Rod

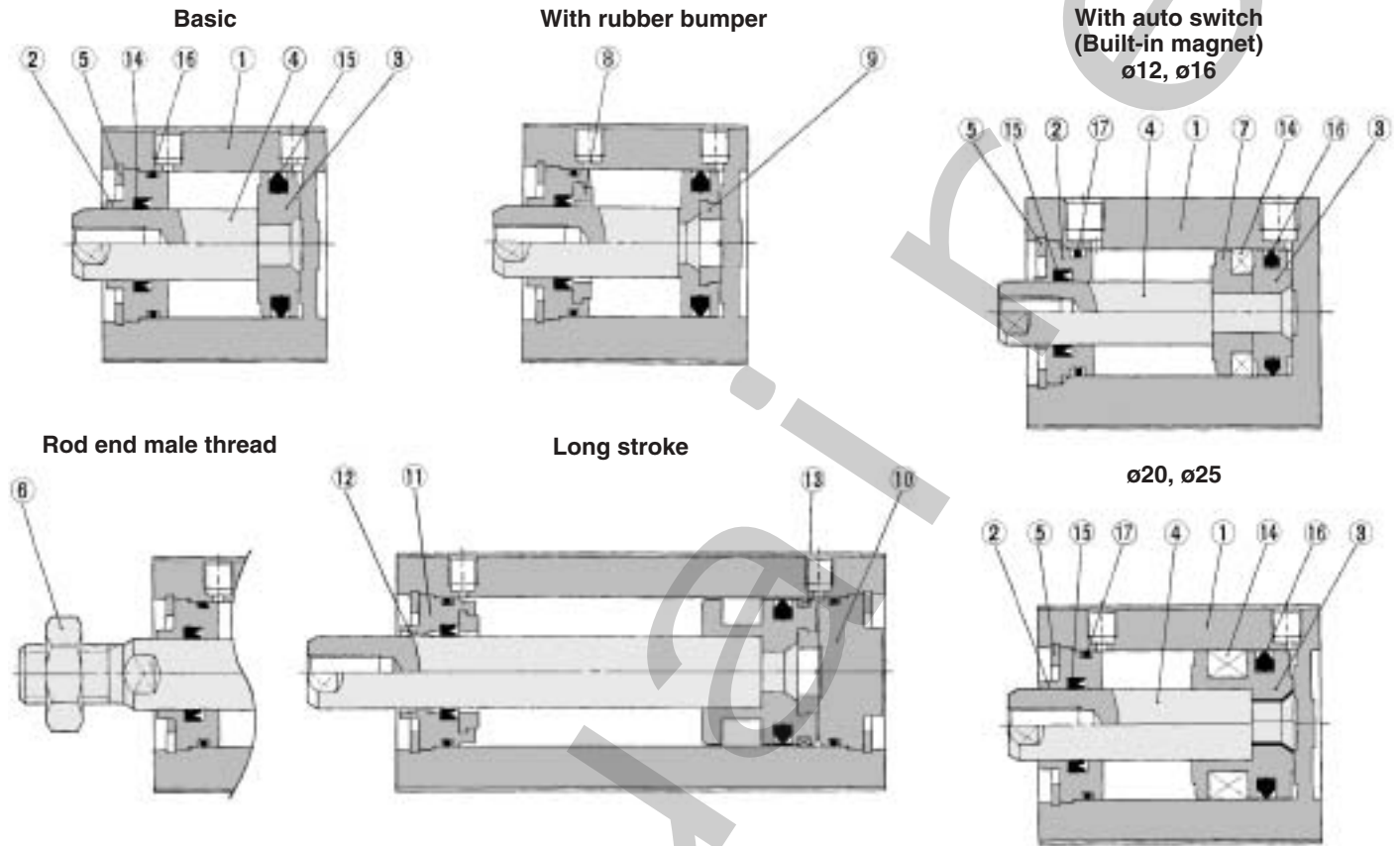

Component Parts

No.	Description	Material	Note
①	Cylinder tube	Aluminum alloy	Hard anodized
②	Collar	Aluminum bearing alloy	Anodized
③	Piston	Aluminum alloy	Chromated
④	Piston rod	Stainless steel	
⑤	Snap ring	Carbon tool steel	Phosphate coating
⑥	Rod end nut	Carbon steel	Nickel plated
⑦	Switch spacer	Aluminum alloy	Chromated
⑧	Bumper A	Urethane	
⑨	Bumper B	Urethane	
⑩	Head cover	Aluminum alloy	Anodized

Component Parts

No.	Description	Material	Note
⑪	Collar	Aluminum alloy	Anodized
⑫	Bushing	Oil impregnated sintered alloy	
⑬	Wearing	Resin	
⑭	Magnet	—	
⑮*	Rod seal	NBR	
⑯*	Piston seal	NBR	
⑰*	Tube gasket	NBR	

Replacement Parts: Seal Kits

Bore size (mm)	Kit No.	Contents
12	CQSB12-PS	Kits includes items ⑮, ⑯ and ⑰ from the table above.
16	CQSB16-PS	
20	CQSB20-PS	
25	CQSB25-PS	

* Seal kits consist of items ⑮, ⑯ and ⑰ contained in one kit, and can be ordered using the order number for each respective tube bore size.

Dimensions — Double Acting Single Rod

Basic (Through-hole/Both ends tapped) /CQSB, CDQSB
 ø12

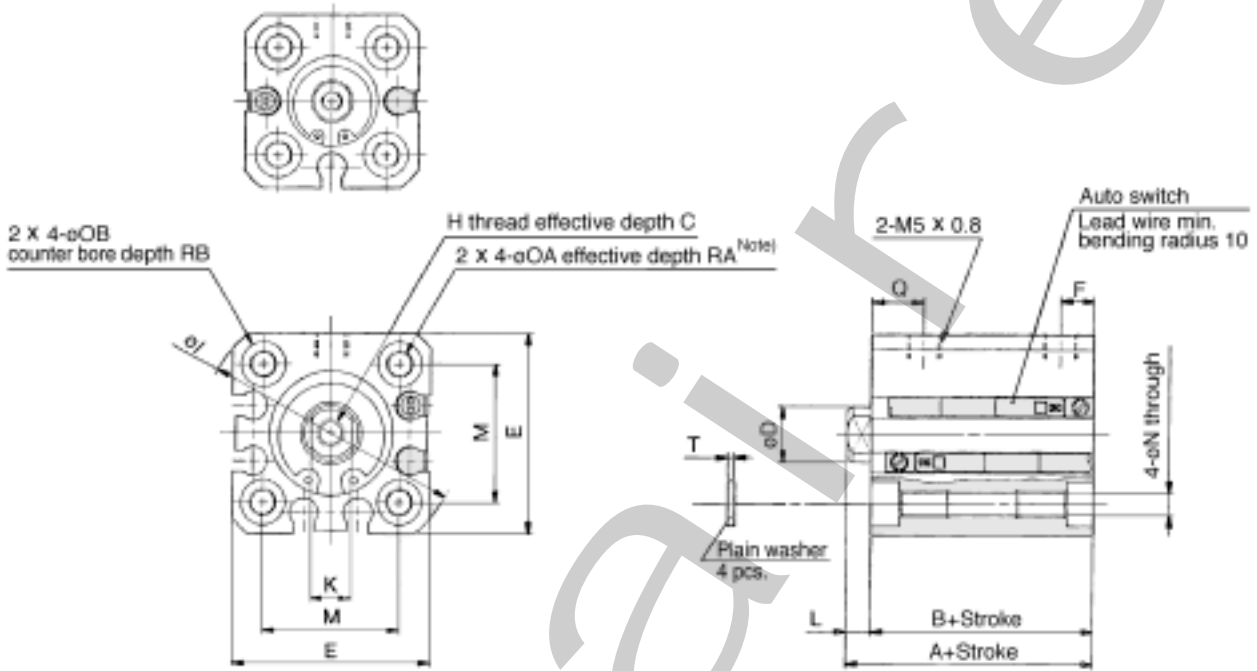

ø16

ø20, ø25

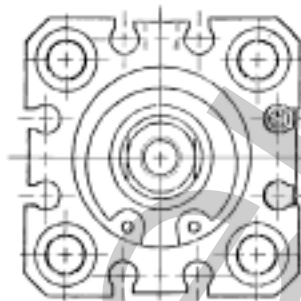

Rod end male thread

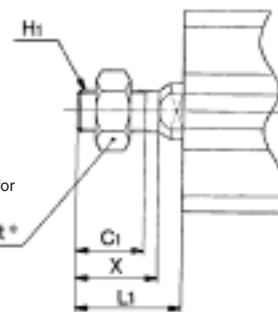

* Refer to page 5 for accessories

Rod end nut*

Basic

("A", "B", "F" and "L" are different between standard stroke and long stroke.)

Bore (mm)	Standard stroke (mm)	Standard stroke								Long stroke (mm)	Long stroke				C	
		Without auto switch				With auto switch					With/Without auto switch				Metric	Inch*
		A	B	F	L	A	B	F	L		A	B	F	L		
12	5 to 30	20.5	17	5	3.5	25.5	22	5	3.5	35 to 100	45.5	32	7.5	13.5	6	5.4
16	5 to 30	20.5	17	5	3.5	25.5	22	5	3.5	35 to 100	45.5	32	7.5	13.5	8	5.4
20	5 to 50	24	19.5	5.5	4.5	34	29.5	5.5	4.5	75 to 200	55.5	41	9	14.5	7	7
25	5 to 50	27.5	22.5	5.5	5	37.5	32.5	5.5	5	75 to 300	59	44	11	15	12	10

Rod End Male Thread Metric

Bore (mm)	Standard	Long stroke	C ₁	H ₁	X
	L ₁	L ₁			
12	14	24	9	M5 x 0.8	10.5
16	15.5	25.5	10	M6 x 1	12
20	18.5	28.5	12	M8 x 1.25	14
25	22.5	32.5	15	M10 x 1.25	17.5

Bore (mm)	D	E	H				I	K	M	N	OA		OB	Q	RA	RB	T
			Metric		Inch*						Metric	inch*					
			Metric	Inch*	Metric	inch*					Metric	inch*					
12	6	25	M3 x 0.5	#8-32UNF	32	5	15.5	3.5	M4 x 0.7	#8-32UNC	6.5	7.5	7	4	0.5		
16	8	29	M4 x 0.7	#8-32UNF	38	6	20	3.5	M4 x 0.7	#8-32UNC	6.5	7.5	7	4	0.5		
20	10	36	M5 x 0.8	#10-32UNF	47	8	25.5	5.4	M6 x 1	1/4-20UNC	9	9	10	7	1		
25	12	40	M6 x 1	1/4-28UNF	52	10	28	5.4	M6 x 1	1/4-20UNC	9	11	10	7	1		

Inch

Bore (mm)	Standard	Long stroke	C ₁	H ₁	X
	L ₁	L ₁			
12	11.5	21.5	6.8	#8-32UNC	8
16	11.5	21.5	6.8	#8-32UNC	8
20	12.5	22.5	6.9	#10-32UNF	8
25	14.5	24.5	8.1	1/4-28UNF	9.5

- For the following bore/stroke sizes, through-hole is threaded over the entire length.
 Basic style ø12 and ø16; 5 stroke, ø20; 5 to 15 stroke, ø25; 5 and 10 stroke, ø20 with auto switch built-in magnet; 5 stroke.
- Rubber bumper style has the same dimensions as those indicated above.
- Note on dimensions: Except where indicated, metric (mm) dimensions are shown. 1inch = 25.4mm
- Dimensions indicated with (*) apply only to inch mounting option (NN thread option, see how to order on page 1).

Series CQS

Compact Cylinder

Dimensions — Double Acting Single Rod

Foot/CQSL, CDQSL

* Refer to page 5 for accessories

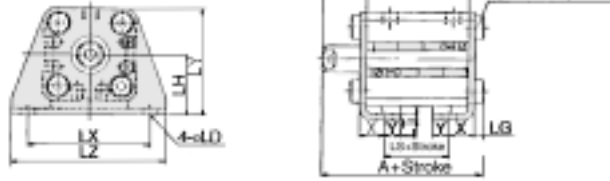

Rod end male thread

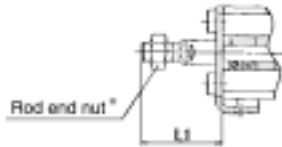

Front flange/CQSF, CDQSF

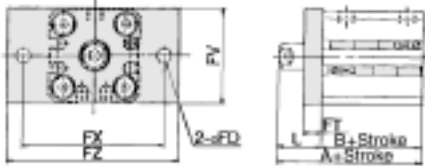

Rod end male thread

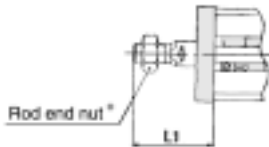

Rear flange/CQSG, CDQSG



Rod end male thread

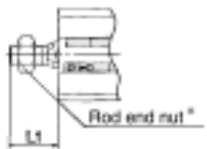

Double clevis/CQSD, CDQSD

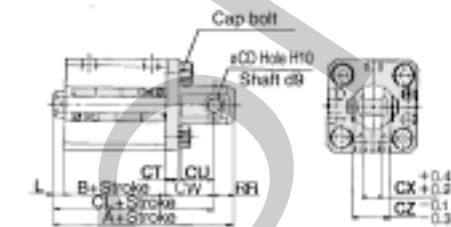

Rod end male thread



(All dimensions are common between standard stroke and long stroke except "A", "B", and "LS".)

Foot

Bore (mm)	Standard stroke (mm)	Standard stroke (mm)						Long stroke (mm)	Long stroke		
		Without auto switch			With auto switch				Without/with auto switch		
		A	B	LS	A	B	LS		A	B	LS
12	5 to 30	35.3	17	5	40.3	22	10	35 to 100	50.3	32	20
16	5 to 30	35.3	17	5	40.3	22	10	35 to 100	50.3	32	20
20	5 to 50	41.2	19.5	7.5	51.2	29.5	17.5	75 to 200	62.7	41	29
25	5 to 50	44.7	22.5	7.5	54.7	32.5	17.5	75 to 300	66.2	44	29

Bore (mm)	L	L ₁		LD	LG	LH	LT	LX	LY	LZ	X	Y
		Metric	Inch*									
12	13.5	24	21.5	4.5	2.8	17	2	34	29.5	44	8	4.5
16	13.5	25.5	21.5	4.5	2.8	19	2	38	33.5	48	8	5
20	14.5	28.5	22.5	6.6	4	24	3.2	48	42	62	9.2	5.8
25	15	32.5	24.5	6.6	4	26	3.2	52	46	66	10.7	5.8

(All dimensions are common between standard stroke and long stroke except "A" and "B".)

Front Flange

Bore (mm)	Standard stroke (mm)	Standard stroke (mm)				Long stroke (mm)	Long stroke	
		Without auto switch		With auto switch			Without/with auto switch	
		A	B	A	B		A	B
12	5 to 30	30.5	17	35.5	22	35 to 100	45.5	32
16	5 to 30	30.5	17	35.5	22	35 to 100	45.5	32
20	5 to 50	34	19.5	44	29.5	75 to 200	55.5	41
25	5 to 50	37.5	22.5	47.5	32.5	75 to 300	59	44

Bore (mm)	FD	FT	FV	FX	FZ	L	L ₁	
							Metric	Inch*
12	4.5	5.5	25	45	55	13.5	24	21.5
16	4.5	5.5	30	45	55	13.5	25.5	21.5
20	6.6	8	39	48	60	14.5	28.5	22.5
25	6.6	8	42	52	64	15	32.5	24.5

(All dimensions are common between standard stroke and long stroke except "A", "B", "L" and "L1".)

Rear Flange

Bore (mm)	Standard stroke (mm)	Standard stroke (mm)										Long stroke (mm)
		Without auto switch					With auto switch					
		A	B	L	L ₁		A	B	L	L ₁		
12	5 to 30	26	17	3.5	14	11.5	31	22	3.5	14	11.5	35 to 100
16	5 to 30	26	17	3.5	15.5	11.5	31	22	3.5	15.5	11.5	35 to 100
20	5 to 50	32	19.5	4.5	18.5	12.5	42	29.5	4.5	18.5	12.5	75 to 200
25	5 to 50	35.5	22.5	5	22.5	14.5	45.5	32.5	5	22.5	14.5	75 to 300

Bore (mm)	Long stroke									
	Without/with auto switch					FD	FT	FV	FX	FZ
	A	B	L	L ₁						
12	51	32	13.5	24	21.5	4.5	5.5	25	45	55
16	51	32	13.5	25.5	21.5	4.5	5.5	30	45	55
20	63.5	41	14.5	28.5	22.5	6.6	8	39	48	60
25	67	44	15	32.5	24.5	6.6	8	42	52	64

(All dimensions are common between standard stroke and long stroke except "A", "B", "C", "L" and "L1".)

Double Clevis

Bore (mm)	Standard stroke (mm)	Standard stroke (mm)											Long stroke (mm)	
		Without auto switch					With auto switch							
		A	B	CL	L	L ₁		A	B	CL	L	L ₁		
12	5 to 30	40.5	17	34.5	3.5	14	11.5	45.5	22	39.5	3.5	14	11.5	35 to 100
16	5 to 30	41.5	17	35.5	3.5	15.5	11.5	46.5	22	40.5	3.5	15.5	11.5	35 to 100
20	5 to 50	51	19.5	42	4.5	18.5	12.5	61	29.5	52	4.5	18.5	12.5	75 to 200
25	5 to 50	57.5	22.5	47.5	5	22.5	14.5	67.5	32.5	57.5	5	22.5	14.5	75 to 300

Bore (mm)	Long stroke													
	Without/with auto switch					CD		CT	CU	CW	CX	CZ	RR	
	A	B	CL	L	L ₁									
12	65.5	32	59.5	13.5	24	21.5	5	3/16	4	7	14	5	10	6
16	66.5	32	60.5	13.5	25.5	21.5	5	3/16	4	10	15	6.5	12	6
20	82.5	41	73.5	14.5	28.5	22.5	8	5/16	5	12	18	8	16	9
25	89	44	79	15	32.5	24.5	10	3/8	5	14	20	10	20	10

- Note on dimensions: Except where indicated, metric (mm) dimensions are shown. 1inch = 25.4mm
- Dimensions indicated with (*) apply only to inch mounting option (NN thread option, see how to order on page 1).

Construction — Double Acting Double Rod

Basic

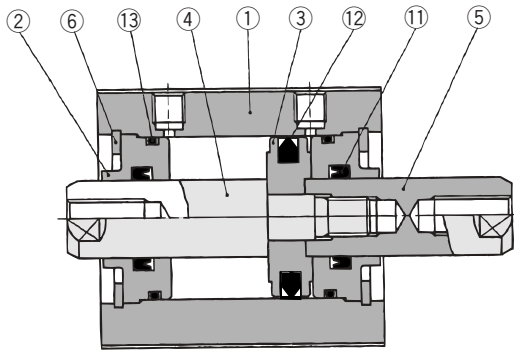

With rubber bumper

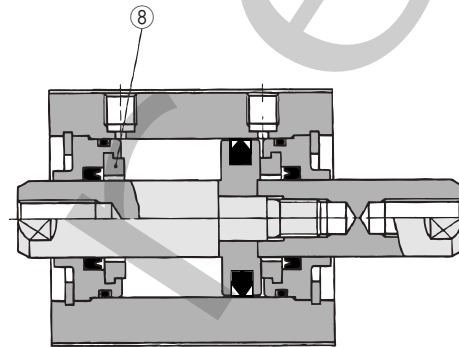

With auto switch (Built-in magnet)

ø12, ø16

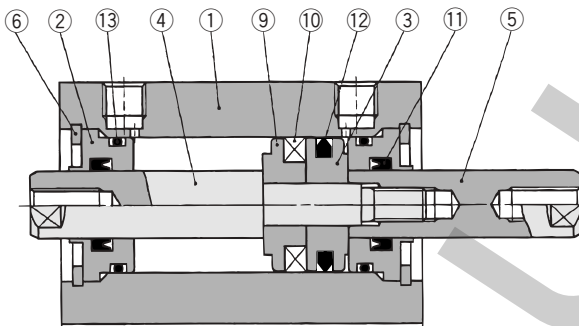

ø20, ø25

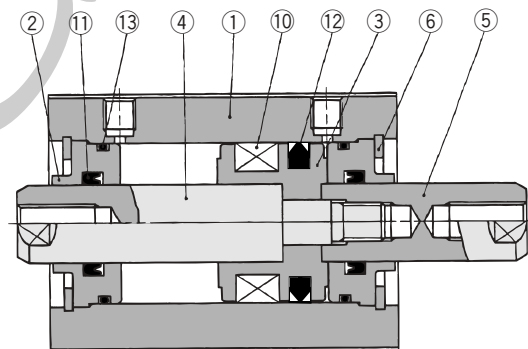

Component Parts

No.	Description	Material	Note
①	Cylinder tube	Aluminum alloy	Hard anodized
②	Collar	Aluminum bearing alloy	Anodized
③	Piston	Aluminum alloy	Chromated
④	Piston rod A	Stainless steel	
⑤	Piston rod B	Stainless steel	
⑥	Snap ring	Carbon tool steel	Phosphate coating
⑦	Rod end nut	Carbon steel	Nickel plated
⑧	Bumper	Urethane	
⑨	Switch spacer	Aluminum alloy	Chromated
⑩	Magnet	—	
⑪	Rod seal	NBR	
⑫	Piston seal	NBR	
⑬	Tube gasket	NBR	

Replacement Parts: Seal Kits

Bore size (mm)	Kit No.	Contents
12	CQSWB12-PS	Kits include items ⑪, ⑫ and ⑬ from the table above.
16	CQSWB16-PS	
20	CQSWB20-PS	
25	CQSWB25-PS	

*Seal kit consist of items ⑪, ⑫ and ⑬ contained in one kit, and can be ordered using the order number for each respective tube bore size.

Rod end male thread

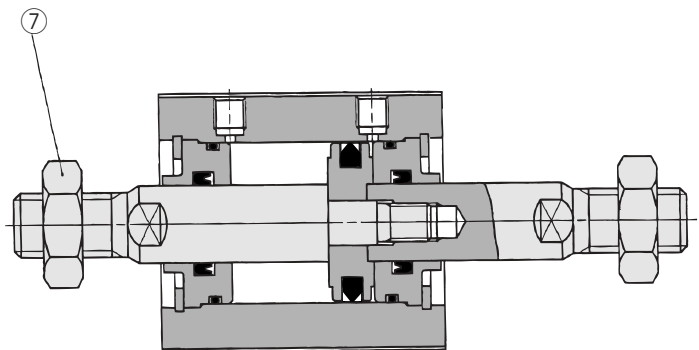

Series CQS

Compact Cylinder

Dimensions — Double Acting Double Rod

Basic (Through-hole/Both ends tapped)/CQSWB, CDQSWB

ø12

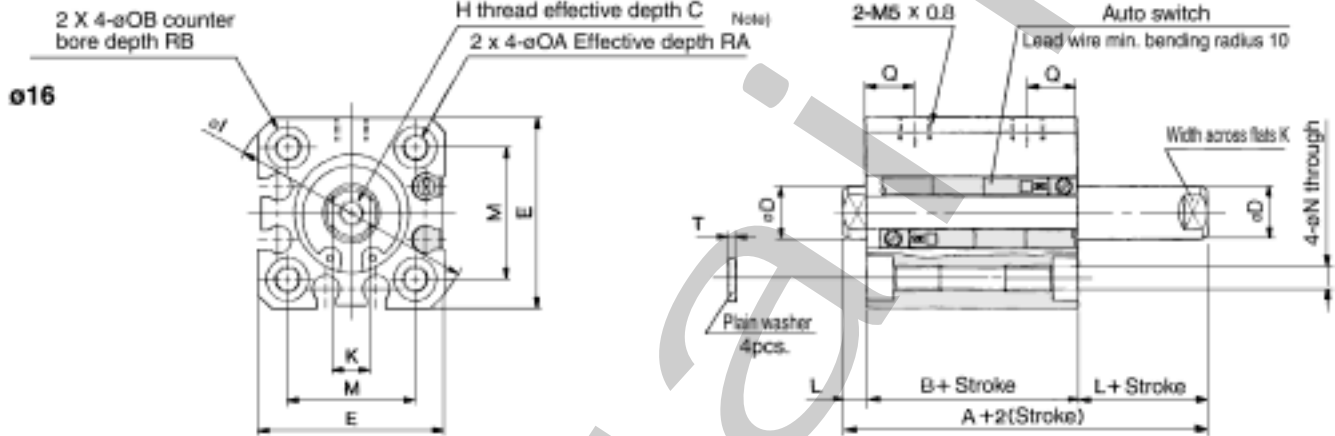
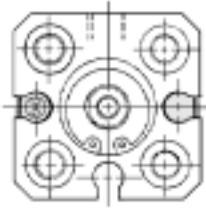

ø20, ø25

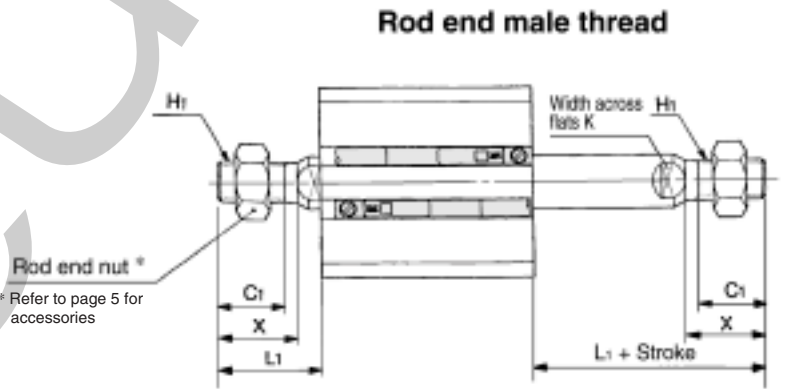
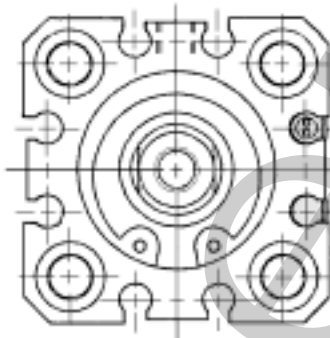

Rod end male thread

Bore (mm)	C ₁		H ₁		L ₁		X	
	Metric	Inch*	Metric	Inch*	Metric	Inch*	Metric	Inch*
12	9	6.8	M5 x 0.8	#8-32UNC	14	11.5	10.5	8
16	10	6.8	M6 x 1.0	#8-32UNC	15.5	11.5	12	8
20	12	6.9	M8 x 1.25	#10-32UNF	18.5	12.5	14	8
25	15	8.1	M10 x 1.25	1/4-28UNF	22.5	14.5	17.5	9.5

Basic

(All dimensions are common except "A" and "B".)

Bore (mm)	Standard stroke (mm)	Without auto switch		With auto switch		C		D	E	H		I	K	L	M	N	OA		OB	Q	RA	RB	T
		A	B	A	B	Metric	Inch*			Metric	Inch*						Metric	Inch*					
		12	5 to 30	29	22	34	27			6	5.4						6	25					
16	5 to 30	29	22	34	27	8	5.4	8	29	M4 x 0.7	#8-32UNC	38	6	3.5	20	3.5	M4 x 0.7	#8-32UNC	6.5	7.5	7	4	0.5
20	5 to 50	35	26	45	36	7	7	10	36	M5 x 0.8	#10-32UNF	47	8	4.5	25.5	5.4	M6 x 1	1/4-20UNC	9	9	10	7	1
25	5 to 50	39	29	49	39	12	10	12	40	M6 x 1	1/4-28UNF	52	10	5	28	5.4	M6 x 1	1/4-20UNC	9	11	10	7	1

- For the following bore/stroke sizes, through-hole is threaded over the entire length.
Basic style ø20 and ø25; 5 stroke.
- Rubber bumper style has the same dimensions as those indicated above.
- Note on dimensions: Except where indicated, metric (mm) dimensions are shown. 1 inch = 25.4mm
- Dimensions indicated with (*) apply only to inch mounting option (NN thread option, see how to order on page 1).

Dimensions — Double Acting Double Rod

Foot/CQSWL, CDQSWL

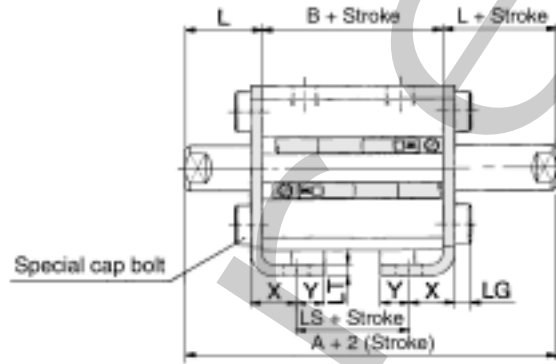
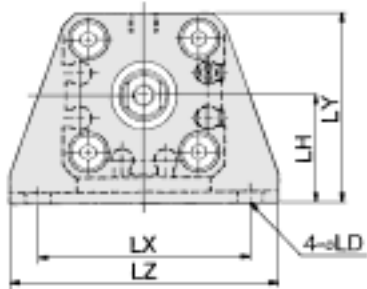

Rod end male thread

Rod end nut *
* Refer to page 5 for accessories

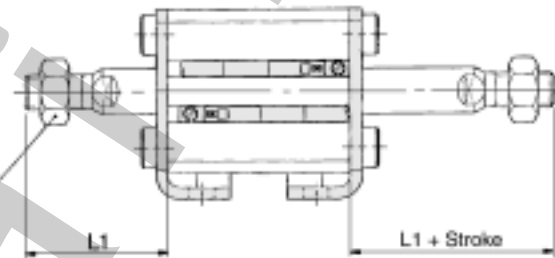

Foot (All dimensions are common except "A", "A1", "B" and "LS".)

Bore (mm)	Standard stroke (mm)	Without auto switch			With auto switch			L	L1		LD	LG	LH	LT	LX	LY	LZ	X	Y
		A	B	LS	A	B	LS		Metric	Inch*									
12	5 to 30	49	22	10	54	27	15	13.5	24	21.5	4.5	2.8	17	2	34	29.5	44	8	4.5
16	5 to 30	49	22	10	54	27	15	13.5	25.5	21.5	4.5	2.8	19	2	38	33.5	48	8	5
20	5 to 50	55	26	14	65	36	24	14.5	28.5	22.5	6.6	4	24	3.2	48	42	62	9.2	5.8
25	5 to 50	59	29	14	69	39	24	15	32.5	24.5	6.6	4	26	3.2	52	46	66	10.7	5.8

Flange/CQSWF, CDQSWF

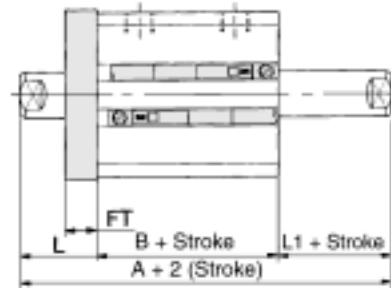
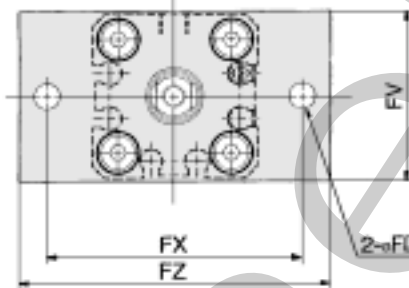

Rod end male thread

Rod end nut *
* Refer to page 5 for accessories



Flange (All dimensions are common except "A", "A1" and "B".)

Bore (mm)	Standard stroke (mm)	Without auto switch		With auto switch		FD	FT	FV	FX	FZ	L	L1	L2		L3	
		A	B	A	B								Metric	Inch*	Metric	Inch*
12	5 to 30	39	22	44	27	4.5	5.5	25	45	55	13.5	3.5	24	21.5	14	11.5
16	5 to 30	39	22	44	27	4.5	5.5	30	45	55	13.5	3.5	25.5	21.5	15.5	11.5
20	5 to 50	45	26	55	36	6.6	8	39	48	60	14.5	4.5	28.5	22.5	18.5	12.5
25	5 to 50	49	29	59	39	6.6	8	42	52	64	15	5	32.5	24.5	22.5	14.5

- Note on dimensions: Except where indicated, metric (mm) dimensions are shown. 1inch = 25.4mm
- Dimensions indicated with (*) apply only to inch mounting option (NN thread option, see how to order on page 1).

Series CQS

Compact Cylinder

Construction — Single Acting Spring Return/Extend

Single acting/Spring return

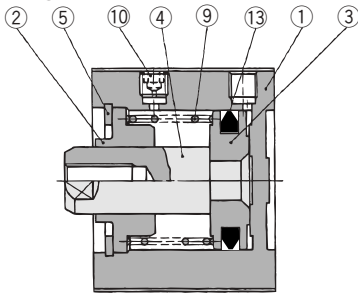

Single acting/Spring extend

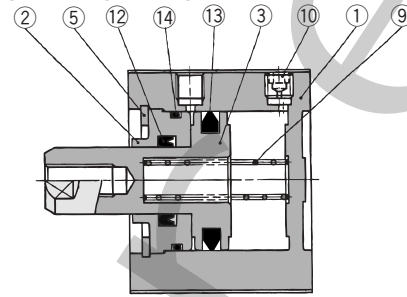

Spring acting/Spring return/With auto switch (Built-in magnet)
ø12, ø16

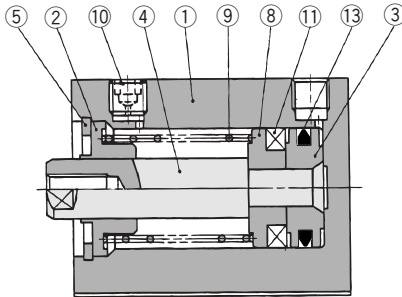

Single acting/Spring extend/With auto switch (Built-in magnet)

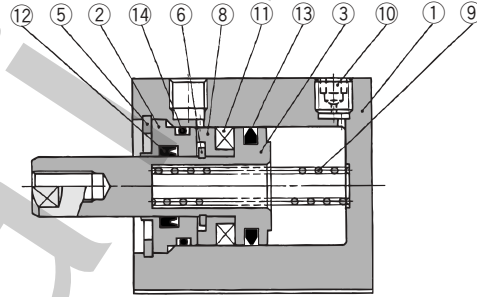

ø20, ø25

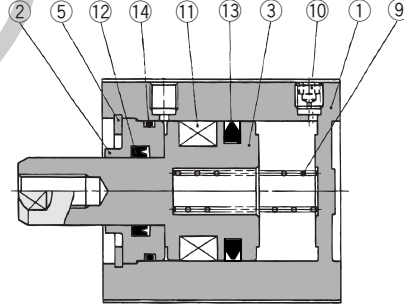
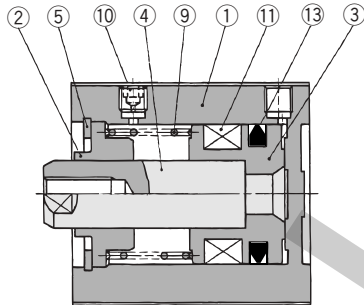

Component Parts

No.	Description	Material	Note
①	Cylinder tube	Aluminum alloy	Hard anodized
②	Collar	Aluminum bearing alloy	Anodized
③	Piston	Aluminum alloy	Spring return
		Stainless steel	Spring extend
④	Piston rod	Stainless steel	
⑤	Snap ring	Carbon tool steel	Phosphate coating
⑥	Snap ring	Carbon tool steel	Nickel plated
⑦	Rod end nut	Carbon steel	Nickel plated
⑧	Switch spacer	Aluminum alloy	Chromated
⑨	Return spring	Piano wire	Zinc chromated
⑩	Plug with fixed orifice	Alloy steel	Nickel plated
⑪	Magnet	—	
⑫*	Rod seal	NBR	
⑬*	Piston seal	NBR	
⑭*	Tube gasket	NBR	

Replacement Parts: Seal Kits

Action	Bore size (mm)	Kit No.	Contents
Single acting Spring return	12	CQSB12-S-PS	Kits include item ⑬ from the table above.
	16	CQSB16-S-PS	
	20	CQSB20-S-PS	
	25	CQSB25-S-PS	

* Seal kits consist of item ⑬ contained in one kit, and can be ordered using the kit number for each respective tube bore size.

Rod end nut

Spring return

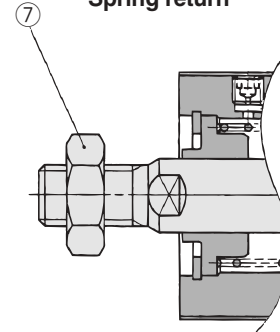

Spring extend

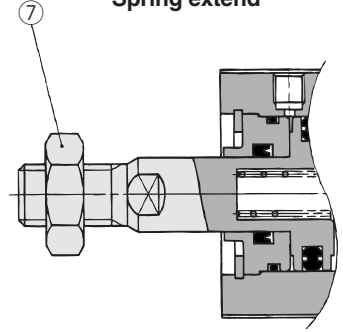

Replacement Parts: Seal Kits

Action	Bore size (mm)	Kit No.	Contents
Single acting Spring extend	12	CQSB12-T-PS	Kits include items ⑫, ⑬ and ⑭ from the table above.
	16	CQSB16-T-PS	
	20	CQSB20-T-PS	
	25	CQSB25-T-PS	

* Seal kits consist of items ⑫, ⑬ and ⑭ contained in one kit, and can be ordered using the kit number for each respective tube bore size.

Dimensions —Single Acting Spring Return

Basic (Through-hole/Both ends tapped)/CQSB, CDQSB

ø12



ø16

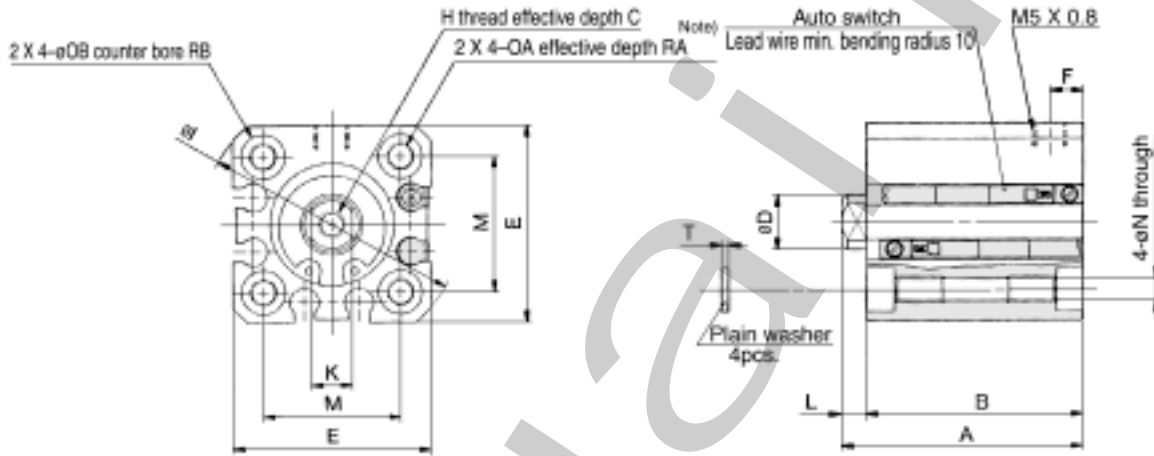

ø20, ø25

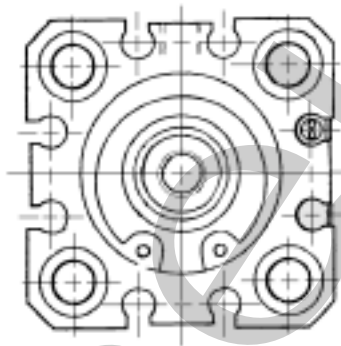

Rod end male thread

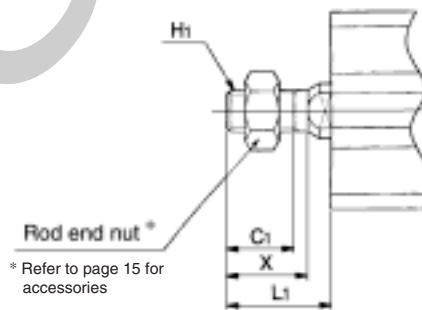

* Refer to page 15 for accessories

Rod end male thread

Bore (mm)	C1		H1		L1		X	
	Metric	Inch*	Metric	Inch*	Metric	Inch*	Metric	Inch*
12	9	6.8	M5 x 0.8	#8-32UNC	14	11.5	10.5	8
16	10	6.8	M6 x 1	#8-32UNC	15.5	11.5	12	8
20	12	6.9	M8 x 1.25	#10-32UNF	18.5	12.5	14	8
25	15	8.1	M10 x 1.25	1/4-28UNF	22.5	14.5	17.5	9.5

Basic

(All dimensions are common except "A" and "B".)

Bore (mm)	Stroke range (mm)	Without auto switch				With auto switch				C	D	E	F	H		I	K	L	M	N	OA		OB	RA	RB	T
		A		B		A		B						Metric	Inch*						Metric	Inch*				
		5 ST	10 ST	5 ST	10 ST	5 ST	10 ST	5 ST	10 ST																	
12	5, 10	25.5	30.5	22	27	30.5	35.5	27	32	5.4	6	25	5	M3 x 0.5	#8-32UNC	32	5	3.5	15.5	3.5	M4 x 0.7	#8-32UNC	6.5	7	4	0.5
16		25.5	30.5	22	27	30.5	35.5	27	32	5.4	8	29	5	M4 x 0.7	#8-32UNC	38	6	3.5	20	3.5	M4 x 0.7	#8-32UNC	6.5	7	4	0.5
20		29	34	24.5	29.5	39	44	34.5	39.5	7	10	36	5.5	M5 x 0.8	#10-32UNF	47	8	4.5	25.5	5.4	M6 x 1	1/4-20UNC	9	10	7	1
25		32.5	37.5	27.5	32.5	42.5	47.5	37.5	42.5	10	12	40	5.5	M6 x 1	1/4-28UNF	52	10	5	28	5.4	M6 x 1	1/4-20UNC	9	10	7	1

- For the following bore/stroke sizes, through-hole is threaded over the entire length.
Basic style ø12 and ø16; 5 stroke, ø20 and ø25; 5 and 10 stroke, ø20 with auto switch built-in magnet; 5 stroke.
- Note on dimensions: Except where indicated, metric (mm) dimensions are shown. 1 inch = 25.4mm
- Dimensions indicated with (*) apply only to inch mounting option (NN thread option, see how to order on page 1).

Series CQS

Compact Cylinder

Dimensions — Single Acting Spring Return

Foot/CQSL, CDQSL* Refer to page 5 for accessories

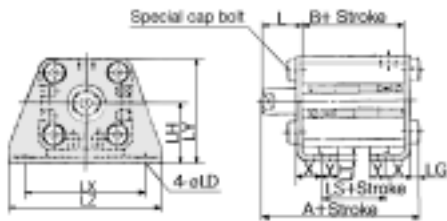

Foot

Bore (mm)	Stroke range (mm)	Without auto switch			With auto switch			L	L1		LD	LG	LH	LT	LX	LY	LZ	X	Y
		A	B	LS	A	B	LS		Metric	Inch*									
12	5, 10	35.3	17	5	40.3	22	10	13.5	24	21.5	4.5	2.8	17	2	34	29.5	44	8	4.5
16		35.3	17	5	40.3	22	10	13.5	25.5	21.5	4.5	2.8	19	2	38	33.5	48	8	5.8
20		41.2	19.5	7.5	51.2	29.5	17.5	14.5	28.5	22.5	6.6	4	24	3.2	48	42	62	9.2	5.8
25		44.7	22.5	7.5	54.7	32.5	17.5	15	32.5	24.5	6.6	4	26	3.2	52	46	66	10.7	5.8

Rod end nut

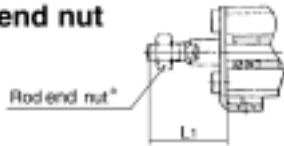

Front flange/CQSF, CDQSF

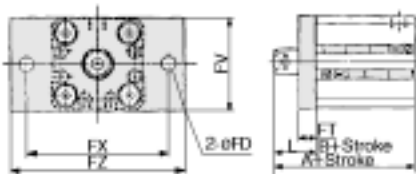

Front Flange

Bore (mm)	Stroke range (mm)	Without auto switch		With auto switch		FD	FT	FV	FX	FZ	L	L1	
		A	B	A	B							Metric	Inch*
12	5, 10	30.5	17	35.5	22	4.5	5.5	25	45	55	13.5	24	21.5
16		30.5	17	35.5	22	4.5	5.5	30	45	55	13.5	25.5	21.5
20		34	19.5	44	29.5	6.6	8	39	48	60	14.5	28.5	22.5
25		37.5	22.5	47.5	32.5	6.6	8	42	52	64	15	32.5	24.5

Rod end nut

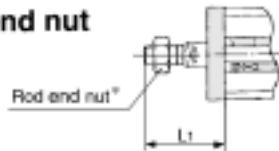

Rear flange nut mounting/CQSG, CDQSG

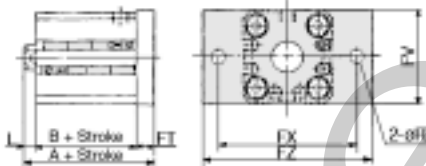

Rear Flange

Bore (mm)	Stroke range (mm)	Without auto switch		With auto switch		FD	FT	FV	FX	FZ	L	L1	
		A	B	A	B							Metric	Inch*
12	5, 10	26	17	31	22	4.5	5.5	25	45	55	3.5	14	11.5
16		26	17	31	22	4.5	5.5	30	45	55	3.5	15.5	11.5
20		32	19.5	42	29.5	6.6	8	39	48	60	4.5	18.5	12.5
25		35.5	22.5	45.5	32.5	6.6	8	42	52	64	5	22.5	14.5

Rod end nut



Double clevis/CQSD, CDQSD

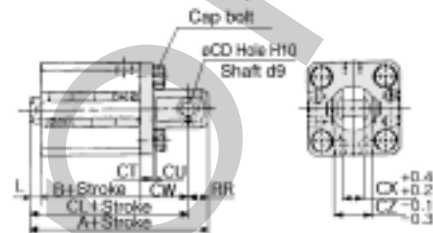

Double Clevis

Bore (mm)	Stroke range (mm)	Without auto switch			With auto switch			CD		CT	CU	CW	CX	CZ	L	L1		RR
		A	B	CL	A	B	CL	Metric	inch*							Metric	Inch*	
12	5, 10	40.5	17	34.5	45.5	22	39.5	5	3/16	4	7	14	5	10	3.5	14.5	11.5	6
16		41.5	17	35.5	46.5	22	40.5	5	3/16	4	10	15	6.5	12	3.5	15.5	11.5	6
20		51	19.5	42	61	29.5	52	8	5/16	5	12	18	8	16	4.5	18.5	12.5	9
25		57.5	22.5	47.5	67.5	32.5	57.5	10	3/8	5	14	20	10	20	5	22.5	14.5	10

Rod end nut

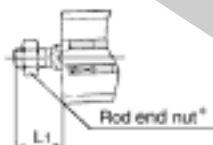

- Note on dimensions: Except where indicated, metric (mm) dimensions are shown. 1inch = 25.4mm
- Dimensions indicated with (*) apply only to inch mounting option (NN thread option, see how to order on page 1).

Dimensions — Single Acting Spring Extend

Basic (Through-hole/Both ends tapped) /CQSB, CDQSB

ø12

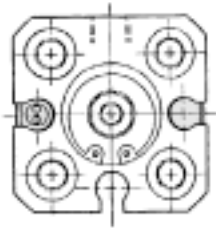

ø16

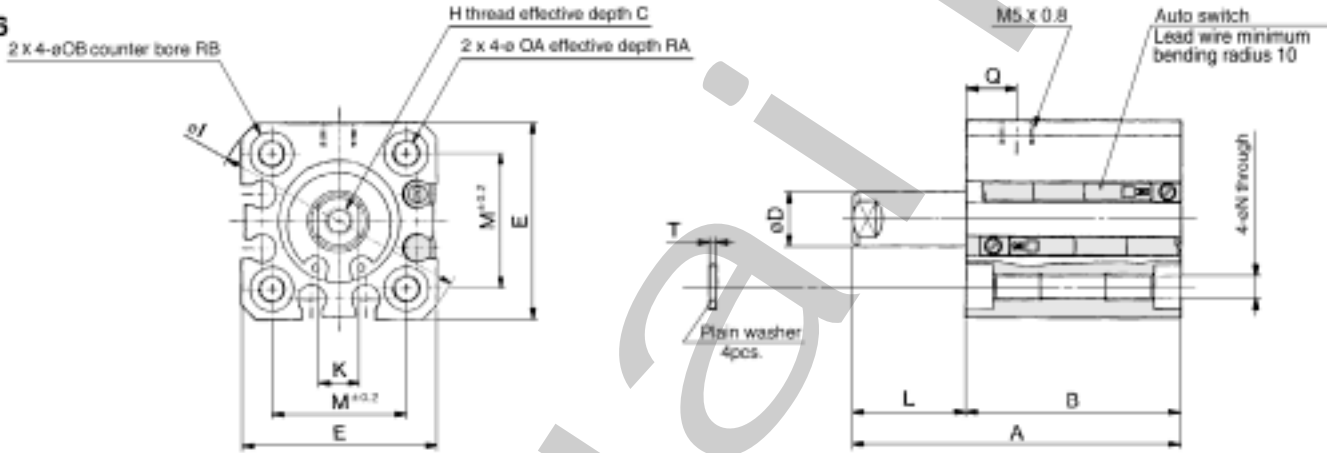

ø20, ø25

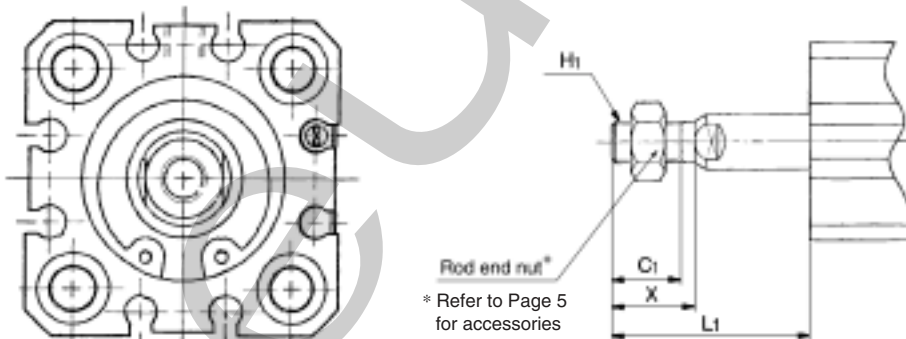

Rod End Male Thread

Bore (mm)	C ₁		H ₁		L ₁				X	
	Metric	Inch*	Metric	Inch*	Metric	Inch*	Metric	Inch*	Metric	Inch*
					5 ST	5 ST	10 ST	10 ST		
12	9	6.8	M5 x 0.8	#8-32UNC	19	16.5	24	21.5	10.5	8
16	10	6.8	M6 x 1	#8-32UNC	20.5	16.5	25.5	21.5	12	8
20	12	6.9	M8 x 1.25	#10-32UNF	23.5	17.5	28.5	22.5	14	8
25	15	8.1	M10 x 1.25	1/4-28UNF	27.5	19.5	32.5	24.5	17.5	9.5

Basic

Bore (mm)	Stroke range (mm)	Without auto switch				With auto switch				C		D	E	H		I	K	L		M	N	OA		OB	Q	RA	RB	T
		A		B		A		B		Metric	Inch*			Metric	Inch*			5 ST	10 ST			Metric	Inch*					
		5 ST	10 ST	5 ST	10 ST	5 ST	10 ST	5 ST	10 ST																			
12	5, 10	30.5	40.5	22	27	35.5	45.5	27	32	6	5.4	6	25	M3 x 0.5	#8-32UNC	32	5	8.5	13.5	15.5	3.5	M4 x 0.7	#8-32UNC	6.5	7.5	7	4	0.5
16		30.5	40.5	22	27	35.5	45.5	27	32	8	5.4	8	29	M4 x 0.7	#8-32UNC	38	6	8.5	13.5	20	3.5	M4 x 0.7	#8-32UNC	6.5	7.5	7	4	0.5
20		34	44	24.5	29.5	44	54	34.5	39.5	7	7	10	36	M5 x 0.8	#10-32UNF	47	8	9.5	14.5	25.5	5.4	M6 x 1	1/4-20UNC	9	9	10	7	1
25		37.5	47.5	27.5	32.5	47.5	57.5	37.5	42.5	12	10	12	40	M6 x 1	1/4-28 UNF	52	10	10	15	28	5.4	M6 x 1	1/4-20UNC	9	11	10	7	1

- For the following bore/stroke sizes, through-hole is threaded over the entire length.
Basic style ø12 and ø16; 5 stroke, ø20 and ø25; 5 and 10 stroke, ø20 with auto switch built-in magnet; 5 stroke.
- Note on dimensions: Except where indicated, metric (mm) dimensions are shown. 1inch = 25.4mm
- Dimensions indicated with (*) apply only to inch mounting option (NN thread option, see how to order on page 1).

Series CQS Compact Cylinder

Dimensions — Single Acting Spring Extend

Foot/CQSL, CDQSL

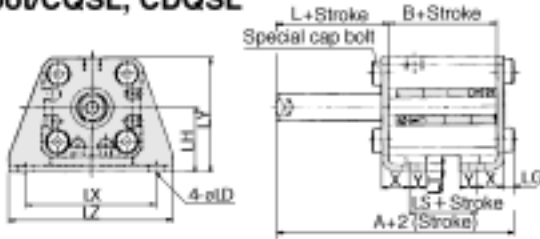

Rod end male thread

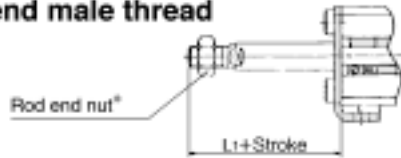

Front flange/CQSF, CDQSF

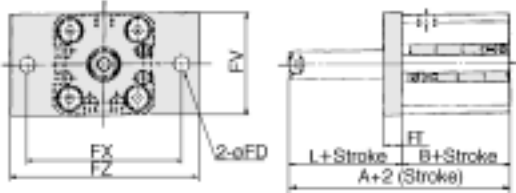

Rod end male thread

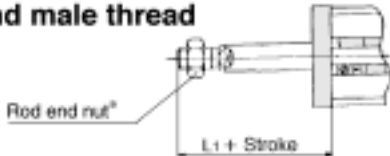

Rear flange/CQSG, CDQSG

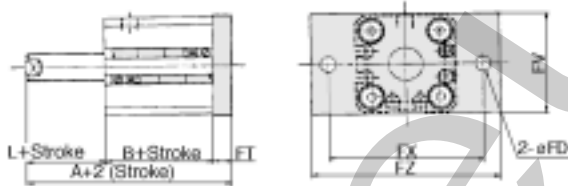

Rod end male thread

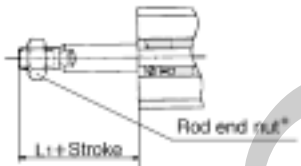

Double clevis/CQSD, CDQSD

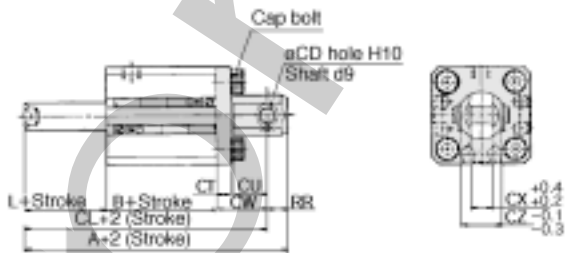

Rod end male thread

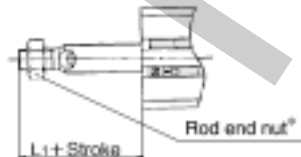

Foot

Bore (mm)	Stroke range (mm)	Without auto switch			With auto switch			L	L ₁	
		A	B	LS	A	B	LS		Metric	Inch*
12	5, 10	35.3	17	5	40.3	22	10	13.5	24	21.5
16		35.3	17	5	40.3	22	10	13.5	25.5	21.5
20		41.2	19.5	7.5	51.2	29.5	17.5	14.5	28.5	22.5
25		44.7	22.5	7.5	54.7	32.5	17.5	15	32.5	24.5
Bore (mm)	LD	LG	LH	LT	LX	LY	LZ	X	Y	
12	4.5	2.8	17	2	34	29.5	44	8	4.5	
16	4.5	2.8	19	2	38	33.5	48	8	5	
20	6.6	4	24	3.2	48	42	62	9.2	5.8	
25	6.6	4	26	3.2	52	46	66	10.7	5.8	

Front Flange

Bore (mm)	Stroke range (mm)	Without auto switch		With auto switch		FD	FT	FV	FX	FZ	L	L ₁	
		A	B	A	B							Metric	Inch*
12	5, 10	30.5	17	35.5	22	4.5	5.5	25	45	55	13.5	24	21.5
16		30.5	17	35.5	22	4.5	5.5	30	45	55	13.5	25.5	21.5
20		34	19.5	44	29.5	6.6	8	39	48	60	14.5	28.5	22.5
25		37.5	22.5	47.5	32.5	6.6	8	42	52	64	15	32.5	24.5

Rear Flange

Bore (mm)	Stroke range (mm)	Without auto switch		With auto switch		FD	FT	FV	FX	FZ	L	L ₁	
		A	B	A	B							Metric	Inch*
12	5, 10	26	17	31	22	4.5	5.5	25	45	55	3.5	14	11.5
16		26	17	31	22	4.5	5.5	30	45	55	3.5	15.5	11.5
20		32	19.5	42	29.5	6.6	8	39	48	60	4.5	18.5	12.5
25		35.5	22.5	45.5	32.5	6.6	8	42	52	64	5	22.5	14.5

Double Clevis

Bore (mm)	Stroke range (mm)	Without auto switch			With auto switch						
		A	B	CL	A	B	CL				
12	5, 10	40.5	17	34.5	45.5	22	39.5				
16		41.5	17	35.5	46.5	22	40.5				
20		51	19.5	42	61	29.5	52				
25		57.5	22.5	47.5	67.5	32.5	57.5				
Bore (mm)	Metric	Inch*	CT	CU	CW	CX	CZ	L	L ₁		RR
									Metric	Inch*	
12	5	3/16	4	7	14	5	10	3.5	14	11.5	6
16	5	3/16	4	10	15	6.5	12	3.5	15.5	11.5	6
20	8	5/16	5	12	18	8	16	4.5	18.5	12.5	9
25	10	3/8	5	14	20	10	20	5	22.5	14.5	10

- Note on dimensions: Except where indicated, metric (mm) dimensions are shown. 1inch = 25.4mm
- Dimensions indicated with (*) apply only to inch mounting option (NN thread option, see how to order on page 1).

* Refer to Page 5 for accessories

Construction — Double Acting Non-rotating Rod

Standard

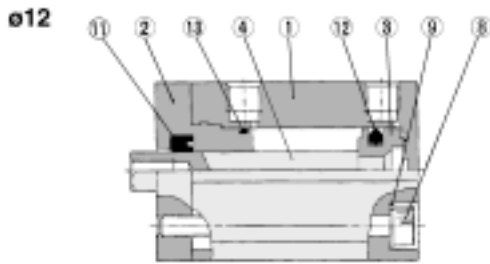

ø16, ø20, ø25

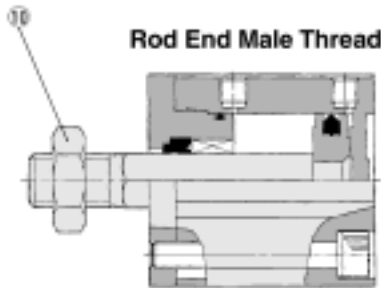
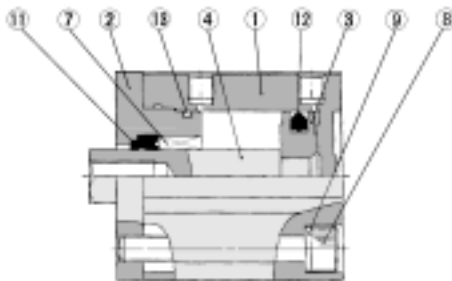

With Auto Switch (Bulit-in Magnet)

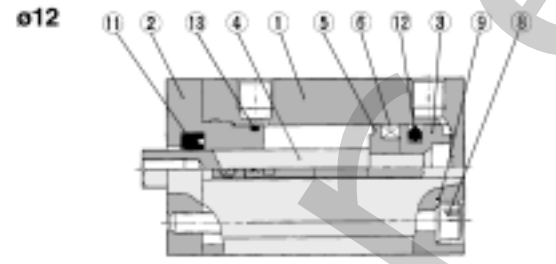

ø16

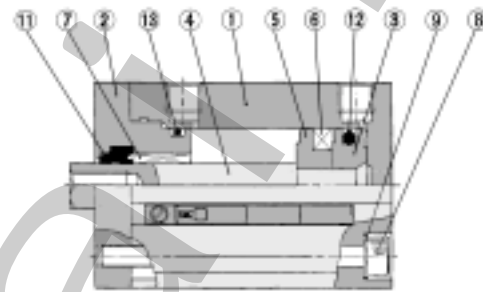

ø20, ø25

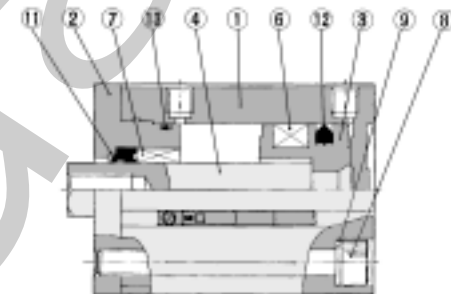

Component Parts

No.	Description	Material	Note
①	Cylinder tube	Aluminum alloy	Hard anodized
②	Rod cover	Aluminum alloy ⁽¹⁾	Anodized
③	Piston	Aluminum alloy	Chromated
④	Piston rod	Stainless steel	
⑤	Switch spacer	Aluminum alloy	Chromated
⑥	Magnet	—	
⑦	Non rotating guide	Oil impregnated sintered alloy	ø16, ø20 and ø25
⑧	Hex. socket head cap screw	Alloy steel	Nickel plated
⑨	Plain washer	Rolled steel	Nickel plated
⑩	Rod end nut	Carbon steel	Nickel plated
⑪*	Rod seal	NBR	
⑫*	Piston seal	NBR	
⑬*	Tube gasket	NBR	

Note 1) ø12: Aluminum bearing alloy.

Replacement Parts: Seal Kits

Bore size (mm)	Kit No.	Contents
12	CQSKB12-PS	Kits include items ⑪, ⑫ and ⑬ from the table above.
16	CQSKB16-PS	
20	CQSKB20-PS	
25	CQSKB25-PS	

*Seal kits consist of items ⑪, ⑫ and ⑬ contained in one kit, and can be ordered using the order number for each respective tube bore size.

⚠ Precautions

⚠ Caution

① Any kind of operation producing rotation torque to piston rod must be considered.

The non-rotating guide would be deformed and the accuracy would be compromised. See the table below for rotation torque allowance.

Allowable rotation torque		ø12	ø16	ø20	ø25
	N-m	0.04	0.04	0.2	0.25
oz-inch	5.6	5.6	28.3	35.4	

② Load to piston rod must always be in an axial direction.

③ When fixing work piece to piston rod end, completely retract the rod before applying any kind of torque. Prevent torque on the guide bushing by holding the rod stationary with a wrench. Do not apply torque directly to the rod.



Series CQS

Compact Cylinder

Dimensions — Non-Rotating Rod: Double Acting Single Rod

Basic (Through-hole/Both ends tapped)/CQSK, CDQSK

ø12

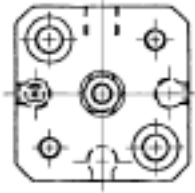

ø16

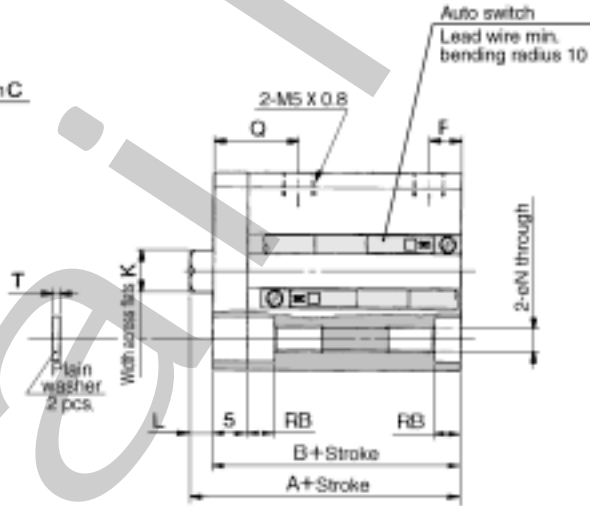
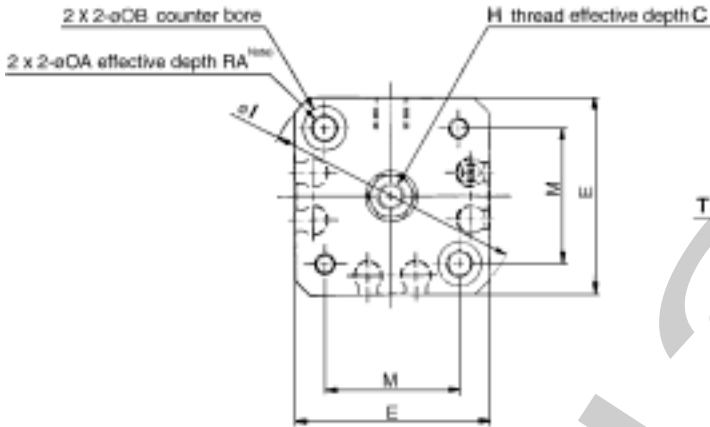

ø20, ø25

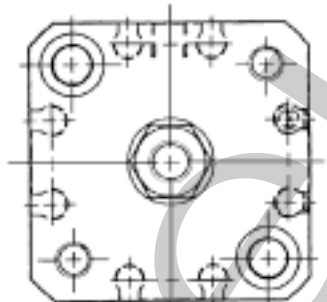

Rod end male thread

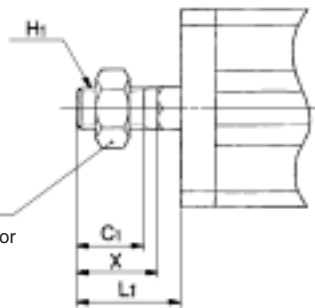

Basic

Bore (mm)	Stroke range (mm)	Without auto switch		With auto switch		C	
		A	B	A	B	Metric	Inch*
12	5 to 30	25.5	22	30.5	27	6	5.4
16	5 to 30	25.5	22	30.5	27	8	5.4
20	5 to 50	29	24.5	39	34.5	7	7
25	5 to 50	32.5	27.5	42.5	37.5	12	10

Rod End Male Thread

Bore (mm)	C1		H1		L1		X	
	Metric	Inch*	Metric	Inch*	Metric	Inch*	Metric	Inch*
12	9	6.8	M5 x 0.8	#8-32UNC	14	11.5	10.5	8
16	10	6.8	M6 x 1	#8-32UNC	15.5	11.5	12	8
20	12	6.9	M8 x 1.25	#10-32UNF	18.5	12.5	14	8
25	15	8.1	M6 x 1.25	1/4-28UNF	22.5	14.5	17.5	9.5

(All dimension are common except "A" and "B").

Bore (mm)	E	F	H		I	K	L	M	N	OA		OB	Q	RA	RB	T
			Metric	Inch*						Metric	Inch*					
12	25	5	M3 x 0.5	#8-32UNC	32	5.2	3.5	15.5	3.5	M4 x 0.7	#8-32UNC	6.5	12.5	7	4	0.5
16	29	5	M4 x 0.7	#8-32UNC	38	6.2	3.5	20	3.5	M4 x 0.7	#8-32UNC	6.5	12.5	7	4	0.5
20	36	5.5	M5 x 0.8	#10-32UNF	47	8.2	4.5	25.5	5.4	M6 x 1	1/4-20UNC	9	14	10	7	1
25	40	5.5	M6 x 1	1/4-28 UNF	52	10.2	5	28	5.4	M6 x 1	1/4-20UNC	9	16	10	7	1

- For the following bore/stroke sizes, through-hole is threaded over the entire length.
Basic style ø12 and ø16; 5 stroke, ø20; 5 to 15 stroke, ø25; 5 and 10 stroke, ø20 with auto switch built-in magnet; 5 stroke.
- Note on dimensions: Except where indicated, metric (mm) dimensions are shown. 1inch = 25.4mm
- Dimensions indicated with (*) apply only to inch mounting option (NN thread option, see how to order on page 1).

Dimensions — Non-Rotating Rod: Double Acting Single Rod

Foot/CQSKL, CDQSKL

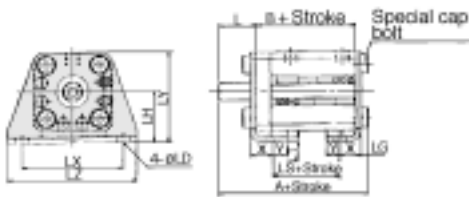

Rod end nut



Front flange/CQSKF, CDQSKF

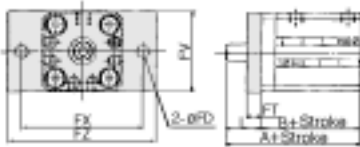

Rod end nut

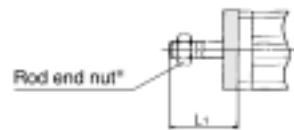

Rear flange/CQSKG, CDQSKG

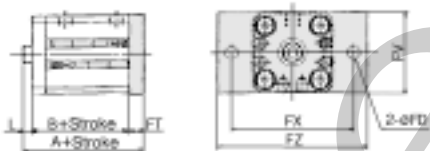

Rod end nut

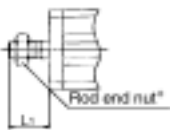

Double clevis/CQSKD, CDQSKD

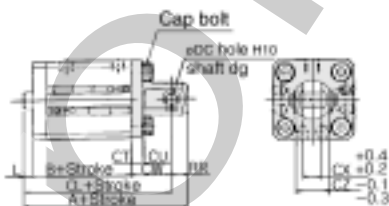

Rod end nut

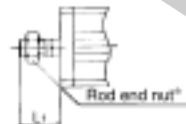

Foot

Bore (mm)	Stroke range (mm)	Without auto switch			With auto switch			L	L ₁		LD	LG	LH	LT
		A	B	LS	A	B	LS		Metric	Inch*				
12	5 to 30	40.3	22	10	45.3	27	15	13.5	24	21.5	4.5	2.8	17	2
16	5 to 30	40.3	22	10	45.3	27	15	13.5	25.5	21.5	4.5	2.8	19	2
20	5 to 50	46.2	24.5	12.5	56.2	34.5	22.5	14.5	28.5	22.5	6.6	4	24	3.2
25	5 to 50	49.7	27.5	12.5	59.7	37.5	22.5	15	32.5	24.5	6.6	4	26	3.2

Bore (mm)	LX	LY	LZ	X	Y
12	34	29.5	44	8	4.5
16	38	33.5	48	8	5
20	48	42	62	9.2	5.8
25	52	46	66	10.7	5.8

Front Flange

Bore (mm)	Stroke range (mm)	Without auto switch		With auto switch		FD	FT	FV	FX	FZ	L	L ₁	
		A	B	A	B							Metric	Inch*
12	5 to 30	35.5	22	40.5	27	4.5	5.5	25	45	55	13.5	24	21.5
16	5 to 30	35.5	22	40.5	27	4.5	5.5	30	45	55	13.5	25.5	21.5
20	5 to 50	39	24.5	49	34.5	6.6	8	39	48	60	14.5	28.5	22.5
25	5 to 50	42.5	27.5	52.5	37.5	6.6	8	42	52	64	15	32.5	24.5

Rear Flange

Bore (mm)	Stroke range (mm)	Without auto switch		With auto switch		FD	FT	FV	FX	FZ	L	L ₁	
		A	B	A	B							Metric	Inch*
12	5 to 30	31	22	36	27	4.5	5.5	25	45	55	3.5	14	11.5
16	5 to 30	31	22	36	27	4.5	5.5	30	45	55	3.5	15.5	11.5
20	5 to 50	37	24.5	47	34.5	6.6	8	39	48	60	4.5	18.5	12.5
25	5 to 50	40.5	27.5	50.5	37.5	6.6	8	42	52	64	5	22.5	14.5

Double Clevis

Bore (mm)	Stroke range (mm)	Without auto switch			With auto switch			CD		CT	CU	CW	CX	CZ
		A	B	CL	A	B	CL	Metric	Inch*					
12	5 to 30	45.5	22	39.5	50.5	27	44.5	5	3/16	4	7	14	5	10
16	5 to 30	46.5	22	40.5	51.5	27	45.5	5	3/16	4	10	15	6.5	12
20	5 to 50	56	24.5	47	66	34.5	57	8	5/16	5	12	18	8	16
25	5 to 50	62.5	27.5	52.5	72.5	37.5	62.5	10	3/8	5	14	20	10	20

Bore (mm)	L	L ₁		RR
		Metric	Inch*	
12	3.5	14	11.5	6
16	3.5	15.5	11.5	6
20	4.5	18.5	12.5	9
25	5	22.5	14.5	10

- Note on dimensions: Except where indicated, metric (mm) dimensions are shown. 1inch = 25.4mm
- Dimensions indicated with (*) apply only to inch mounting option (NN thread option, see how to order on page 1).