

Compact Cylinder with Solenoid Valve/ Guide Rod Type

Labor, energy and space are saved by integrated structure.

Solenoid valve

Compact cylinder/Guide rod type

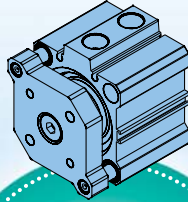
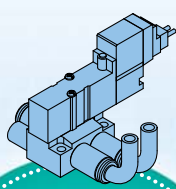

Labor saving

- No need to select size of valve
- Less piping work

Energy saving

- Approx. 50% reduction in air consumption between cylinder and valve

Space saving

- Small mounting space with valve integrated structure

Non-rotating accuracy

$\pm 0.1^\circ$ or less



Lateral load resisting 2 to 3 times

* Compared to the CDQ2 series

Load can be directly mounted.

Mounting pitch is interchangeable with the CQ2 series.

Guide rod

Solenoid valve

Auto switch



Variations

Bore size (mm)	Standard stroke (mm)											
	5	10	15	20	25	30	35	40	45	50	75	100
32	●	●	●	●	●	●	●	●	●	●	●	●
40	●	●	●	●	●	●	●	●	●	●	●	●
50		●	●	●	●	●	●	●	●	●	●	●
63		●	●	●	●	●	●	●	●	●	●	●

Series **CVQM**



CAT.ES20-207A

Series CVQM

Guide rod configuration with improved lateral load resistance and non-rotating accuracy

- Allowable lateral load of the plate is 2 to 3 times better than the CDQ2 series.
- Plate non-rotating accuracy $\pm 0.1^\circ$

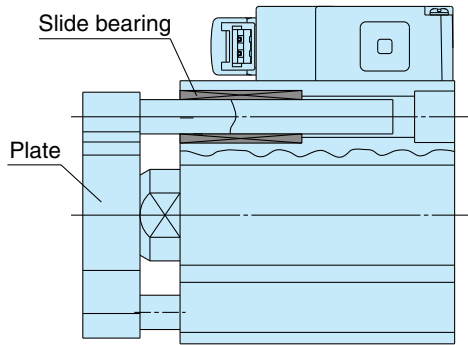

Small 2-color indication solid state auto switch can be mounted.

- A round slot for mounting small auto switches is provided on 3 surfaces.

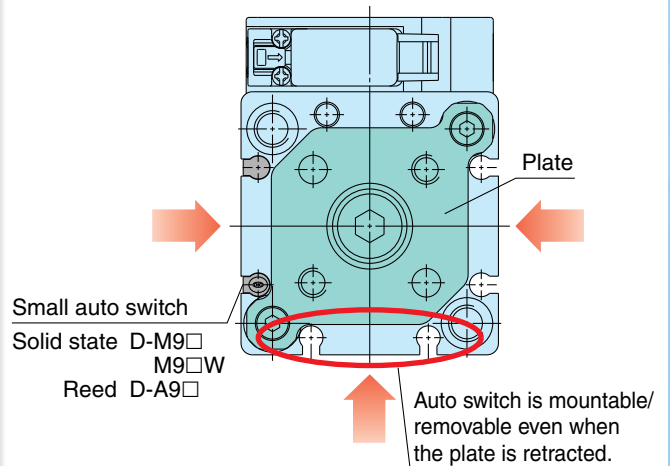

Height comparison (Dimensional difference: C)

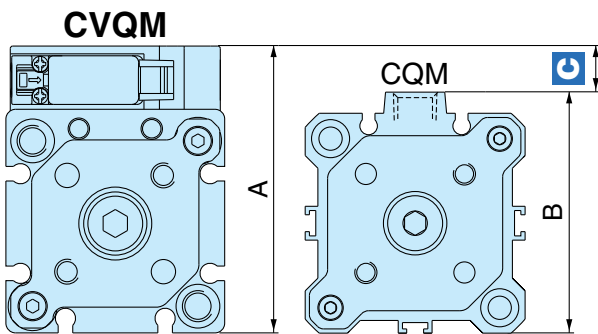

(mm)			
Bore size	A	B	C
32	59	49.5	9.5
40	67	57	10
50	83	71	12
63	97	84	13

Mounting example

- Two ways of mounting are possible.
- Mounting pitch is interchangeable with the CQ2 series.

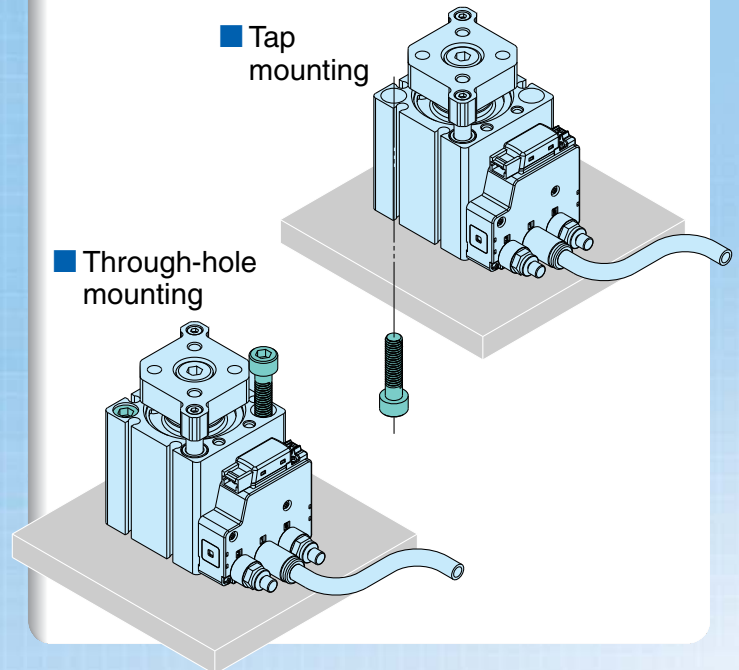

Compact Cylinder with Solenoid Valve/ Guide Rod Type

Series CVQM

ø32, ø40, ø50, ø63



How to Order

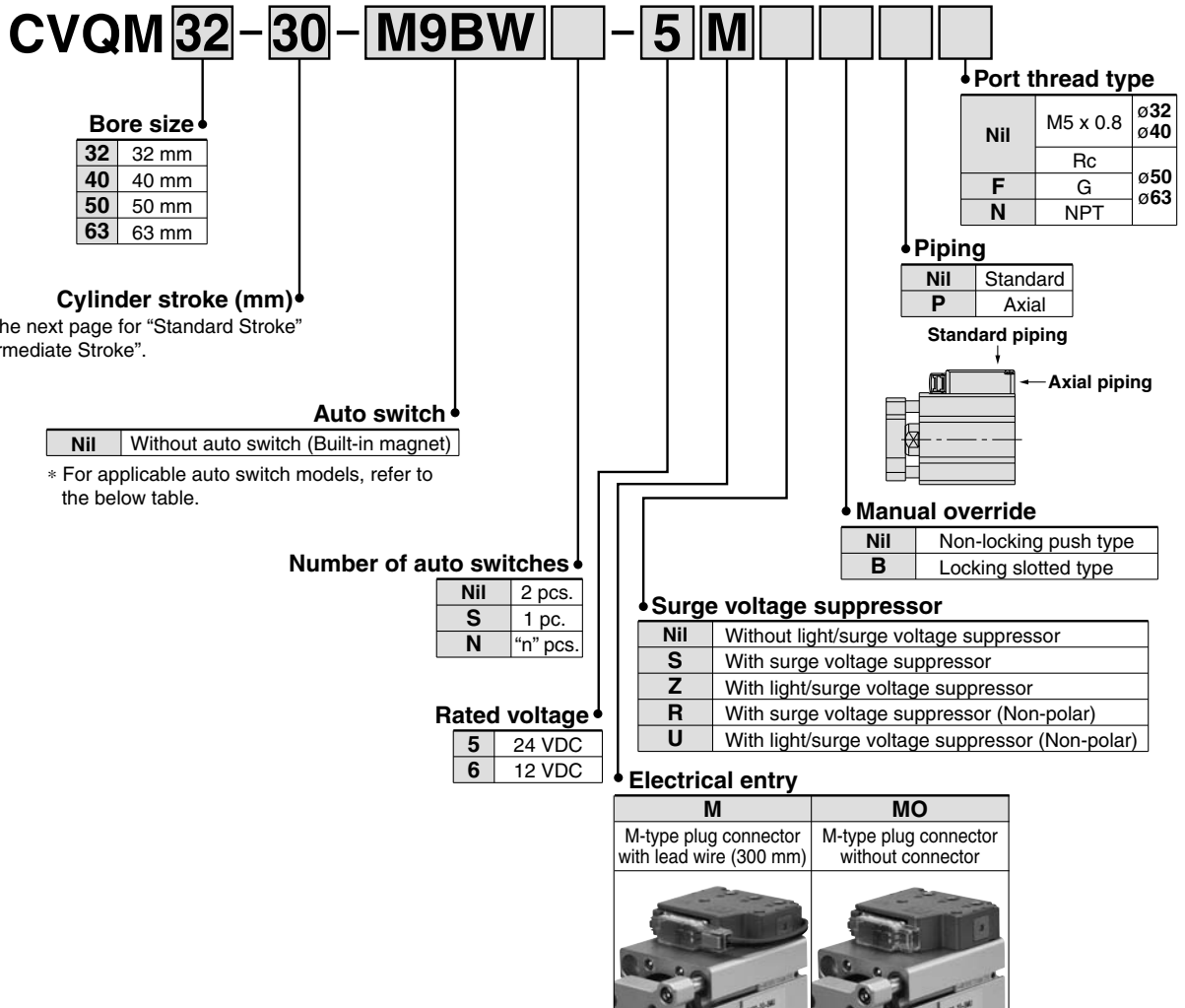

* For lead wire lengths other than 300 mm, refer to the plug connector lead wire. (Page 5)

Applicable Auto Switches/Refer to pages 11 to 13 for detailed auto switch specifications.

Type	Special function	Electrical entry	Indicator light	Wiring (Output)	Load voltage		Auto switch model		Lead wire length (m)*				Pre-wired connector	Applicable load	
					DC	AC	Electrical entry		0.5 (Nil)	1 (M)	3 (L)	5 (Z)		IC circuit	Relay, PLC
							Perpendicular	In-line							
Solid state auto switch	Diagnostic indication (2-color indication)	Grommet	Yes	3-wire (NPN)	24 V	5 V, 12 V	—	M9NV	M9N	●	●	●	○	—	—
				3-wire (PNP)				M9PV	M9P	●	●	●	○		
				2-wire	24 V	5 V, 12 V	—	M9BV	M9B	●	●	●	○	—	—
				3-wire (NPN)				M9NVW	M9NW	●	●	●	○		
				3-wire (PNP)				M9PVW	M9PW	●	●	●	○	—	—
				2-wire				M9BVW	M9BW	●	●	●	○		
Reed auto switch	—	Grommet	Yes	3-wire (NPN equivalent)	24 V	5 V	100 V	A96V	A96	●	—	●	—	—	—
				2-wire				A93V	A93	●	—	●	—		
				—	5 V, 12 V	100 V or less	A90V	A90	●	—	●	—	—	—	

* Lead wire length symbols: 0.5 m Nil (Example) M9NW
 1 m M M9NWM
 3 m L M9NWL
 5 m Z M9NWZ

* Solid state auto switches marked with "○" are produced upon receipt of order.
 * For details about auto switches with pre-wired connector, refer to pages 1784 and 1785 of Best Pneumatics No. 3.
 * Auto switches are shipped together, (but not assembled).

Series CVQM



⚠ Caution

1. Do not separate the cylinder from the valve.
2. Do not disassemble or modify the guide rod.
3. This product should not be used as a stopper.

JIS Symbol

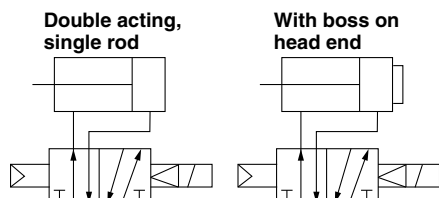

Standard Stroke

Bore size	Standard stroke (mm)
32 *1	5, 10, 15, 20, 25, 30, 35 40, 45, 50, 75, 100
40	5, 10, 15, 20, 25, 30, 35 40, 45, 50, 75, 100
50 *2	10, 15, 20, 25, 30, 35 40, 45, 50, 75, 100
63	10, 15, 20, 25, 30, 35 40, 45, 50, 75, 100

- *1 The outline dimensions for 5 mm stroke will be the same as those for 10 mm stroke.
*2 The outline dimensions for 10 mm stroke will be the same as those for 15 mm stroke.

Theoretical Output

Unit: N

Bore size (mm)	Operating direction	Operating pressure (MPa)		
		0.3	0.5	0.7
32	IN	181	302	422
	OUT	241	402	563
40	IN	317	528	739
	OUT	377	628	880
50	IN	495	825	1150
	OUT	589	982	1370
63	IN	840	1400	1960
	OUT	936	1560	2184

Cylinder Specifications

Bore size (mm)	32	40	50	63
Action	Double acting, Single rod			
Fluid	Air (Non-lube)			
Proof pressure	1.0 MPa			
Maximum operating pressure	0.7 MPa			
Minimum operating pressure	0.15 MPa			
Ambient and fluid temperature	-10 to 50°C (No freezing)			
Stroke tolerance	0 to +1.0 mm*			
Mounting	Through-hole/Both ends tapped			
Piston speed	50 to 500 mm/s		50 to 300 mm/s	
Cushion	Rubber bumper			

* Stroke length tolerance does not include the amount of bumper change.

Valve Specifications

Type of actuation	2-position single
Manual override	Non-locking push type/Locking slotted type
Pilot exhaust	Main/Pilot valve common exhaust type
Mounting orientation	Unrestricted (based on cylinder mounting orientation)
Enclosure	Dustproof

Solenoid Specifications

Electrical entry	M-type plug connector	
Coil rated voltage	DC	24, 12 (V)
Allowable voltage range ^{Note)}	±10% of the rated voltage	
Power consumption	DC	0.35 (With light: 0.4) W
Surge voltage suppressor	Diode (Non-polar: Varistor)	
Indicator light	LED	

Note) The S and Z types of surge voltage suppressor have an internal circuit allowing voltage drop, so use within the following allowable voltage range.
S, Z type 24 VDC: -7% to +10%
12 VDC: -4% to +10%

Intermediate Stroke

Part no.	Refer to "How to Order" for standard model numbers. (Previous page)	
Description	Spacers are installed in a cylinder with standard stroke.	
	Bore size	Description
	32	Available in 1 mm stroke increments
Stroke range (mm)	Bore size	Stroke range
	32	1 to 99
	40, 50, 63	5 to 95
Example	Part no.: CVQM32-95-□ A spacer 5 mm in width is installed in standard cylinder CVQM32-100-□. B dimension: 133 mm	

Weight

Unit (g)

Bore size (mm)	Stroke											
	5	10	15	20	25	30	35	40	45	50	75	100
32	349	344	368	393	417	441	465	489	514	538	660	782
40	435	464	492	520	548	577	605	633	661	690	828	966
50	—	834	865	908	952	995	1039	1081	1125	1168	1386	1603
63	—	1088	1139	1190	1241	1292	1343	1394	1445	1496	1751	2006

Mounting Bolt for CVQM

Mounting: Be sure to use it as through-hole when mounting.

Ordering: Add the word, "Bolt" in front of the bolts to be used.

Example) Bolt M5 x 45L: 4 pcs.

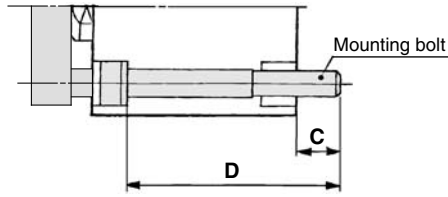

Cylinder model	C	D	Mounting bolt size
CVQM32- 5	9	45	M5 x 45L
- 10		45	x 45L
- 15		50	x 50L
- 20		55	x 55L
- 25		60	x 60L
- 30		65	x 65L
- 35		70	x 70L
- 40		75	x 75L
- 45		80	x 80L
- 50		85	x 85L
- 75		110	x 110L
-100		135	x 135L
CVQM40- 5	7.5	45	M5 x 45L
- 10		50	x 50L
- 15		55	x 55L
- 20		60	x 60L
- 25		65	x 65L
- 30		70	x 70L
- 35		75	x 75L
- 40		80	x 80L
- 45		85	x 85L
- 50		90	x 90L
- 75		115	x 115L
-100		140	x 140L

Cylinder model	C	D	Mounting bolt size
CVQM50- 10	12.5	60	M6 x 60L
- 15		60	x 60L
- 20		65	x 65L
- 25		70	x 70L
- 30		75	x 75L
- 35		80	x 80L
- 40		85	x 85L
- 45		90	x 90L
- 50		95	x 95L
- 75		120	x 120L
-100		145	x 145L
CVQM63- 10		14.5	60
- 15	65		x 65L
- 20	70		x 70L
- 25	75		x 75L
- 30	80		x 80L
- 35	85		x 85L
- 40	90		x 90L
- 45	95		x 95L
- 50	100		x 100L
- 75	125		x 125L
-100	150		x 150L

Plate Non-rotating Accuracy

Non-rotating accuracy without load is designed to be same or less than the figures shown in the table below at the retracted cylinder end (plate).

Bore size (mm)	Non-rotating accuracy
32 to 63	$\pm 0.1^\circ$

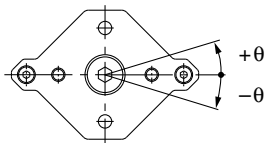
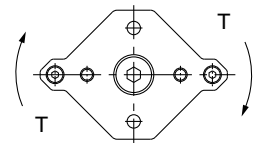

Plate Allowable Rotational Torque

Make sure to operate strictly within the allowable rotation torque range to the plate.

Operation outside of this range may result in shorter service life or damage to the device.



Unit: N·m

Bore size (mm)	Cylinder stroke (mm)											
	5	10	15	20	25	30	35	40	45	50	75	100
32	0.66	0.59	0.53	0.49	0.45	0.42	0.39	0.36	0.34	0.32	0.25	0.20
40	1.06	0.96	0.88	0.81	0.75	0.70	0.65	0.61	0.58	0.55	0.43	0.36
50	—	1.70	1.56	1.45	1.35	1.26	1.19	1.12	1.06	1.01	0.80	0.67
63	—	3.90	3.62	3.37	3.15	2.96	2.80	2.65	2.51	2.39	1.92	1.61

Series CVQM

Plate Allowable Lateral Load

Make sure to operate strictly within the allowable lateral load range to the plate.

Operation outside of this range may result in shorter service life or damage to the device.

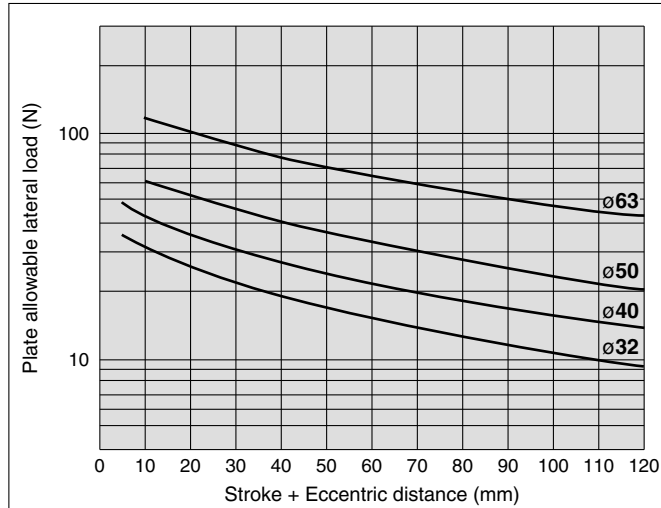
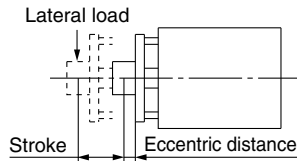

Allowable Kinetic Energy

Make sure to operate strictly within the allowable range of the load weight and maximum speed.

Operation outside of this range may cause excessive impact, which may result in the damage to the device.

Operating pressure: 0.5 MPa

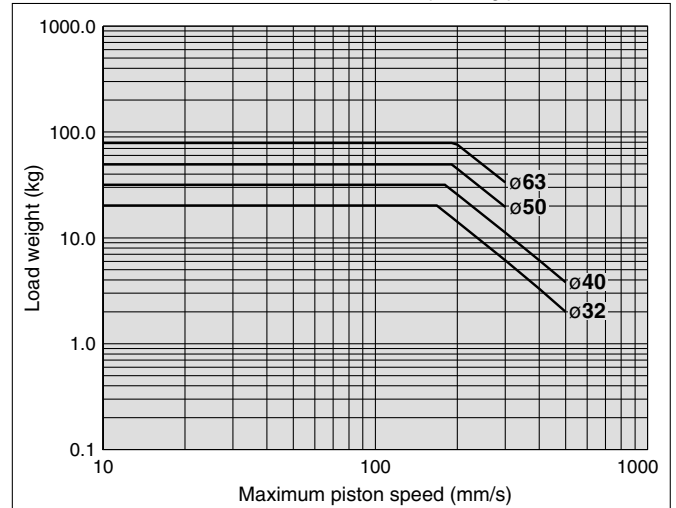

Relationship between Number of Needle Rotations and Piston Speed

$\phi 32, \phi 40$

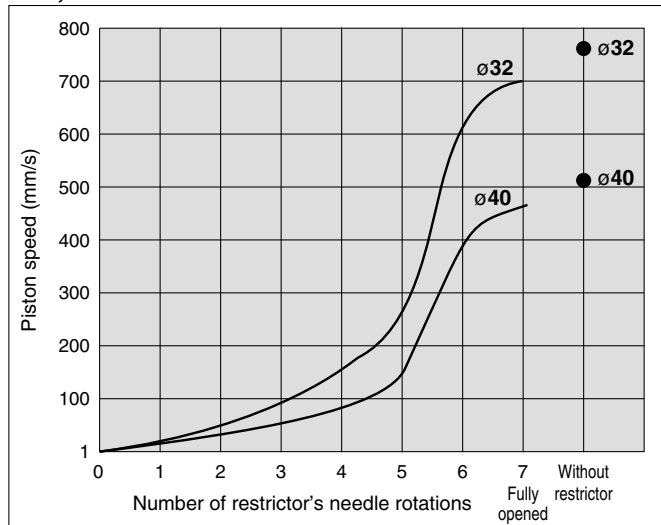

Restrictor: ASN2-M5

Pressure: 0.5 MPa

Mounting orientation: Horizontal, No-load, Piston extended

* The above piston speed is for reference purpose only.

$\phi 50, \phi 63$

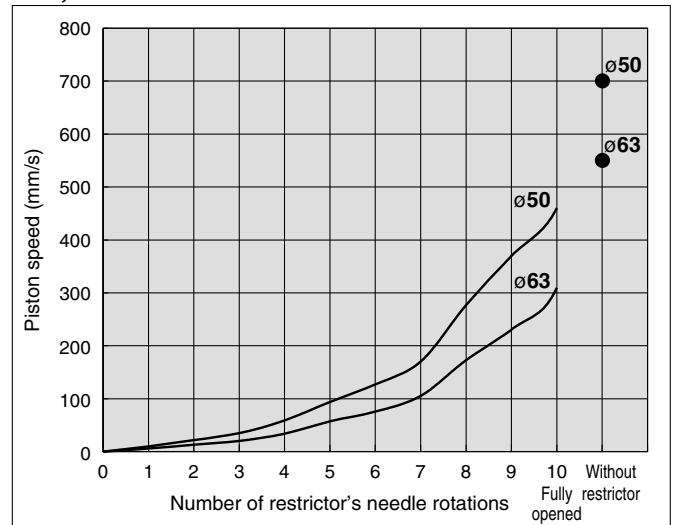

Restrictor: ASN2-01

Pressure: 0.5 MPa

Mounting orientation: Horizontal, No-load, Piston extended

* The above piston speed is for reference purpose only.

< Exhaust restrictor with silencer >



Applicable bore size (mm)	Model	Port size	Effective area (mm ²)	Weight (g)
32, 40	ASN2-M5	M5 x 0.8	1.8	5
50, 63	ASN2-01	1/8	3.6	17

Construction

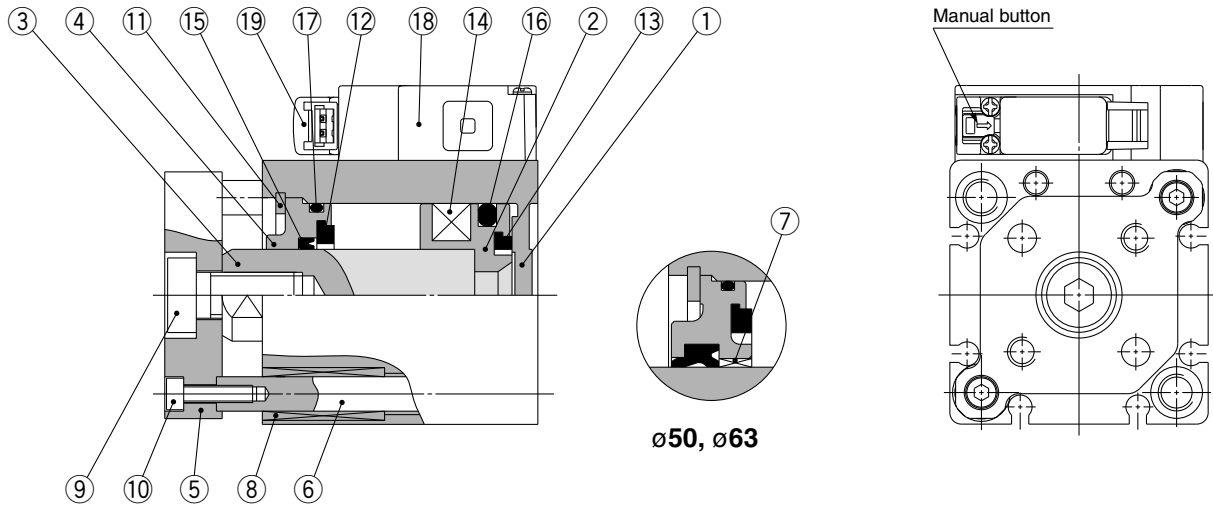

Component Parts

No.	Description	Material	Note
1	Cylinder tube	Aluminum alloy	Hard anodized
2	Piston	Aluminum alloy	Chromated
3	Piston rod	Carbon steel	Hard chrome plated
4	Collar	Alluminum alloy casted	ø50, ø63, Chromated, painted
		Aluminum alloy	ø32, ø40, Anodized
5	Plate	Aluminum alloy	Anodized
6	Guide rod	Stainless steel	Hard chrome plated
7	Bushing	Bearing alloy	ø50, ø63
8	Bushing	Oil impregnated sintered alloy	
9	Hexagon socket head bolt	Carbon steel	Nickel plated
10	Hexagon socket head bolt	Carbon steel	Nickel plated
11	Retaining ring	Carbon tool steel	Phosphate coated
12	Bumper A	Urethane	
13	Bumper B	Urethane	
14	Magnet	—	
15	Rod seal	NBR	
16	Piston seal	NBR	
17	Gasket	NBR	
18	Solenoid valve	—	
19	Pilot valve	—	

Length of plug connector lead wire

The standard length of the plug connector with a lead wire is 300 mm, but other lengths are available as follows.

How to Order Pilot Valve Assembly

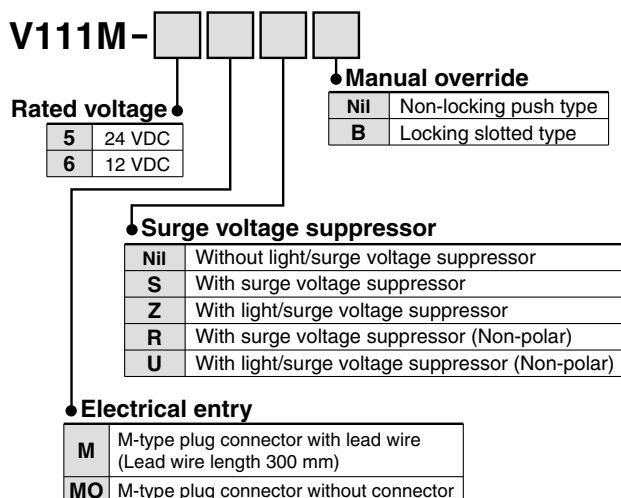

How to Order Connector Assembly

With lead wire: SY100-30-4A-[]

Lead wire length

Lead wire length	20	25	30	50
Nil	300 mm	600 mm	1000 mm	1500 mm
6	2000 mm	2500 mm	3000 mm	5000 mm

How to Order

Indicate the part number of the connector assembly in addition to the part number of the solenoid valve without the connector for the plug connector. Example) Lead wire length 2000 mm

When ordering cylinder with valve
CVQM32-30-M9B-5MOZ
SY100-30-4A-20

Series CVQM

Dimensions

ø32 to ø63

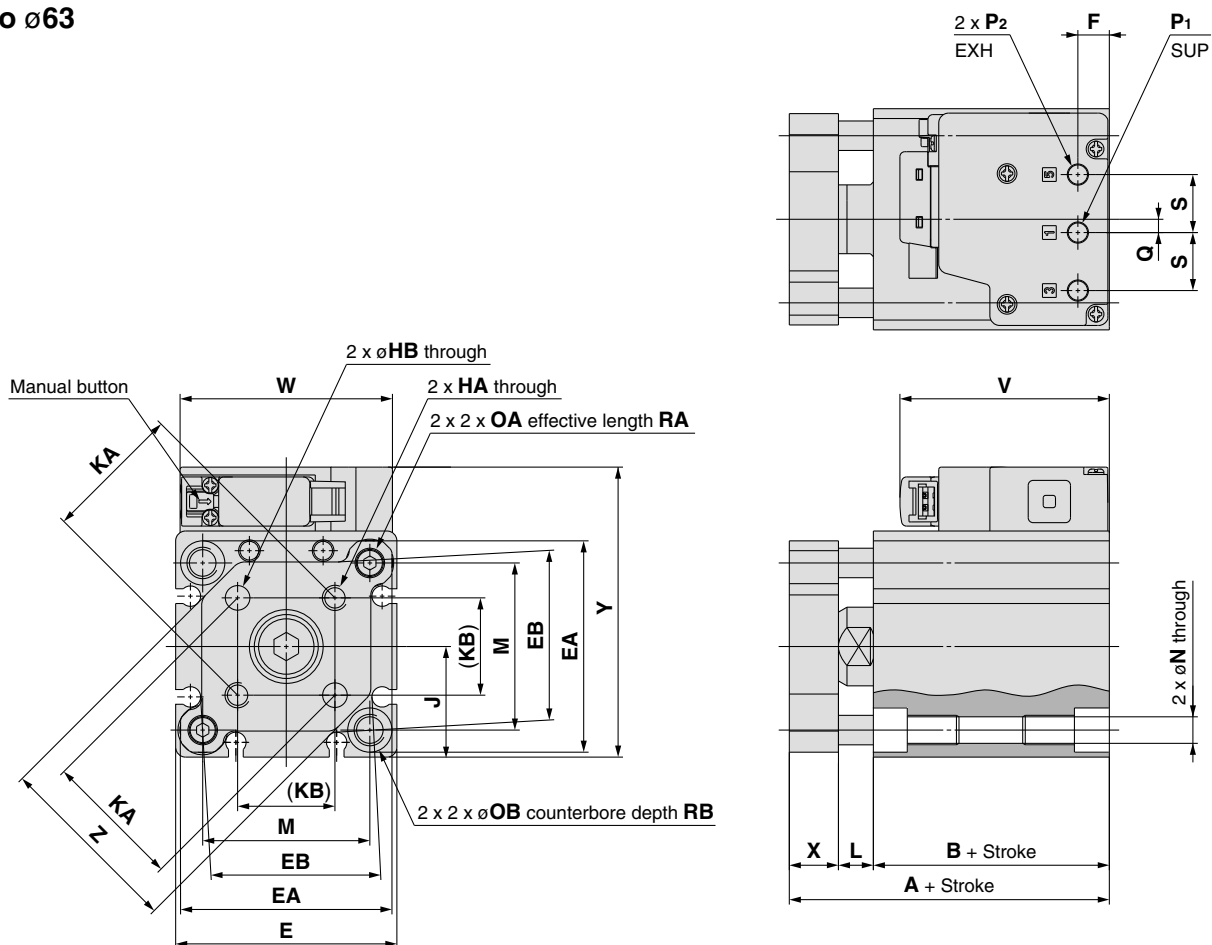

Axial piping

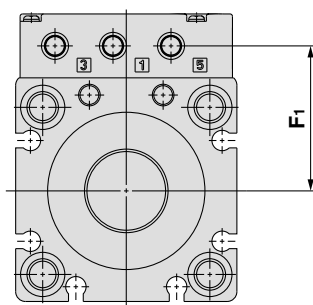

Bore size (mm)	F ₁
32	30
40	34.5
50	43.5
63	51

Bore size (mm)	Stroke range (mm)	A	B	E	EA	EB	F	HA	HB	J	KA	KB	L	M	N	OA
32	5 to 100	40 <small>Note 1)</small>	33 <small>Note 1)</small>	45	43	34.4	6.5	M5 x 0.8	5 ^{+0.2} ₀	22.5	28 ±0.2	19.8	7	34	5.4	M6 x 1
40	5 to 100	46.5	39.5	52	50	41.4	6.5	M5 x 0.8	5 ^{+0.2} ₀	26	33 ±0.2	23.3	7	40	5.4	M6 x 1
50	10 to 100	48.5 <small>Note 2)</small>	40.5 <small>Note 2)</small>	64	62	53.4	7.5	M6 x 1	6 ^{+0.2} ₀	32	42 ±0.2	29.7	8	50	6.6	M8 x 1.25
63	10 to 100	54	46	77	74	59.6	7.5	M6 x 1	6 ^{+0.2} ₀	38.5	50 ±0.2	35.4	8	60	9	M10 x 1.5

Note 1) The dimensions (A + stroke) and (B + stroke) for 5 mm stroke will be the same as those for 10 mm stroke.

Note 2) The dimensions (A + stroke) and (B + stroke) for 10 mm stroke will be the same as those for 15 mm stroke.

Bore size (mm)	Stroke range (mm)	OB	P ₁	P ₂	Q	RA	RB	S	V	W	Y	Z
32	5 to 100	9	M5 x 0.8	M5 x 0.8	2.5	10	7	12	43	43.5	59	38
40	5 to 100	9	M5 x 0.8	M5 x 0.8	2.5	10	7	12	43	43.5	67	46
50	10 to 100	11	Rc, G, NPT1/8	Rc, G, NPT1/8	3.5	14	8	17	54	63	83	58
63	10 to 100	14	Rc, G, NPT1/8	Rc, G, NPT1/8	3.5	18	10.5	17	54	63	97	69

Auto Switch Proper Mounting Position (Detection at Stroke End) and Mounting Height

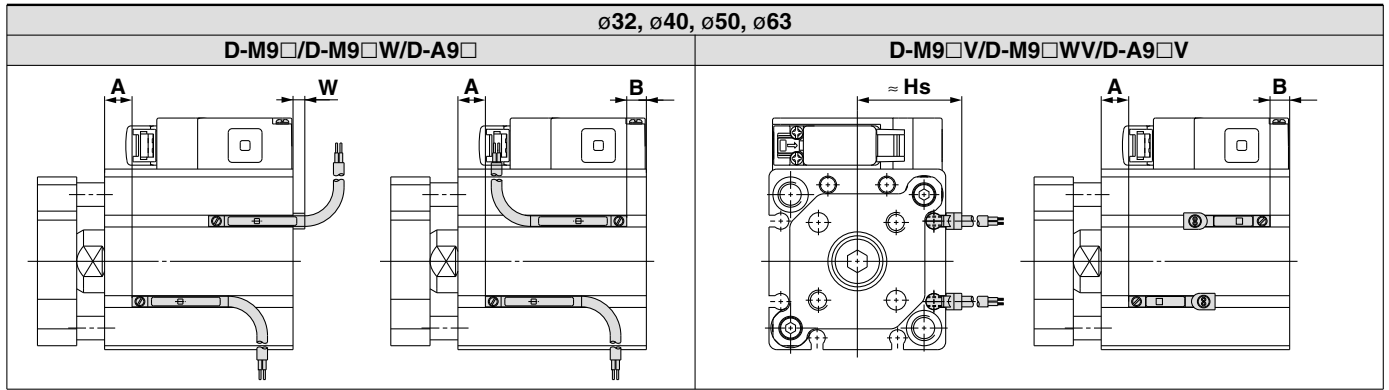

Bore size (mm)	D-M9□ D-M9□W			D-M9□V D-M9□WV			D-A9□			D-A9□V		
	A	B	W	A	B	Hs	A	B	W	A	B	Hs
32	12 [17]	9	1	12 [17]	9	29	8 [13]	5	-3 (-0.5)	8 [13]	5	27
40	16	11.5	-1.5	16	11.5	32.5	12	7.5	-5.5 (-3)	12	7.5	30.5
50	14 <19>	14.5	-4.5	14 <19>	14.5	42	10 <15>	10.5	-8.5 (-6)	10 <15>	10.5	36.5
63	16.5	17.5	-7.5	16.5	17.5	42	12.5	13.5	-11.5 (-9)	12.5	13.5	40

- []: Values for 5 mm stroke with ø32
 < >: Values for 10 mm stroke with ø50
 (): Values for the D-A93
 * The negative indication in the table for W shows the mounting inside the cylinder body.
 * For the actual setting, check the operating condition of the auto switch and adjust.

Auto Switch Mountable Surface, Mounting Groove Number (Direct Mounting)

The below table shows which surfaces of the cylinder an auto switch can be mounted on, and the number of grooves for the direct mounting style auto switch.

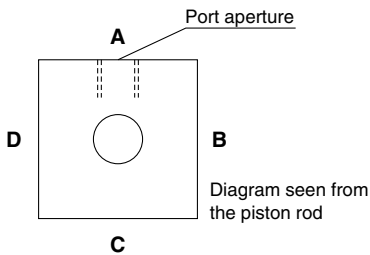

Auto switch model	D-M9□(V), M9□W(V), A9□(V)			
	A (Mounting groove number)	B (Mounting groove number)	C (Mounting groove number)	D (Mounting groove number)
32	—	○ (2)	○ (2)	○ (2)
40	—	○ (2)	○ (2)	○ (2)
50	—	○ (2)	○ (2)	○ (2)
63	—	○ (2)	○ (2)	○ (2)

Operating Range

Auto switch model	Bore size (mm)			
	32	40	50	63
D-M9□, D-M9□V D-M9□W, D-M9□WV	6	6	7	7.5
D-A9□, D-A9□V	9.5	9.5	9.5	11.5

- * Since this is a guideline including hysteresis, not meant to be guaranteed. (assuming approximately ±30% dispersion)
 There may be the case it will vary substantially depending on the ambient environment.

Auto Switch Mounting

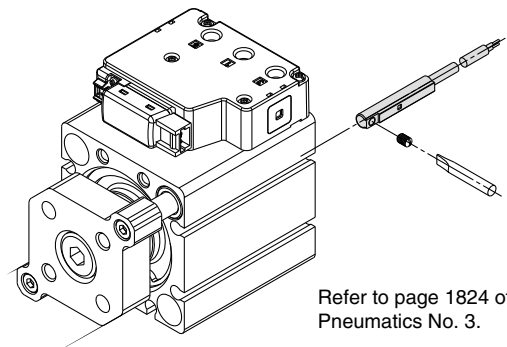

Minimum Stroke for Auto Switch Mounting

Bore size (mm)	Number of auto switches mounted	D-M9□	D-M9□V	D-M9□W	D-M9□WV	D-A9□	D-A9□V
32*1, 40	1	10	5	15	10	10	5
50*2, 63	2	10	5	15	15	10	10

- *1 The outline dimensions for 5 mm stroke will be the same as those for 10 mm stroke.
 *2 The outline dimensions for 10 mm stroke will be the same as those for 15 mm stroke.

Prior to Use

Auto Switches Common Specifications 1

⚠ Specific Product Precautions

Before handling auto switches, refer to "Handling Precautions for SMC Products" (M-E03-3) for Auto Switches Precautions.

Auto Switches Common Specifications

Type	Reed auto switch	Solid state auto switch
Leakage current	None	3-wire: 100 μ A or less, 2-wire: 0.8 mA or less
Operating time	1.2 ms	1 ms or less
Impact resistance	300 m/s ²	1000 m/s ²
Insulation resistance	50 M Ω or more at 500 VDC Mega (Between lead wire and case)	
Withstand voltage	1500 VAC for 1 minute (Between lead wire and case)	1000 VAC for 1 minute (Between lead wire and case)
Ambient temperature	-10 to 60°C	
Enclosure	IEC60529 Standard IP67	

Lead Wire

Lead wire length indication

(Example)

D-M9BW **L**

● Lead wire length

Nil	0.5 m
M	1 m
L	3 m
Z	5 m

Note 1) Lead wire length Z: 5 m

Applicable auto switches

Solid state auto switch: Manufactured upon receipt of order as standard.

Note 2) Lead wire length tolerance

Lead wire length	Tolerance
0.5 m	\pm 15 mm
1 m	\pm 30 mm
3 m	\pm 90 mm
5 m	\pm 150 mm

Prior to Use

Auto Switches Common Specifications 2

⚠ Specific Product Precautions

Before handling auto switches, refer to "Handling Precautions for SMC Products" (M-E03-3) for Auto Switches Precautions.

Auto Switch Hysteresis

Hysteresis is the distance between the position at which piston movement operates an auto switch and the position at which reverse movement turns the switch off. This hysteresis is included in part of the operating range (single side).

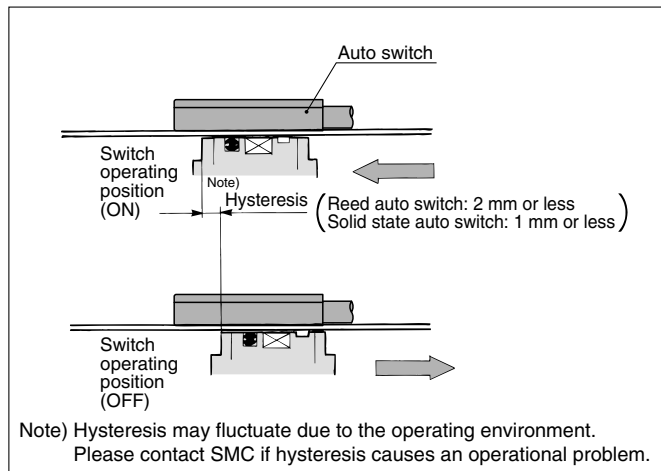

Contact Protection Box: CD-P11, CD-P12

<Applicable switch models>

D-A9/A9□V

The auto switches above do not have a built-in contact protection circuit. A contact protection box is not required for solid state auto switches due to their construction.

- ① Where the operation load is an inductive load.
- ② Where the wiring length to load is greater than 5 m.
- ③ Where the load voltage is 100 VAC.

Therefore, use a contact protection box with the switch for any of the above cases:

The contact life may be shortened (due to permanent energizing conditions.)

Where the load voltage is 110 VAC.

When the load voltage is increased by more than 10% to the rating of applicable auto switches above, use a contact protection box (CD-P11) to reduce the upper limit of the load current by 10% so that it can be set within the range of the load current range, 110 VAC.

Contact Protection Box Specifications

Part no.	CD-P11	CD-P12
Load voltage	100 VAC or less	200 VAC
Max. load current	25 mA	12.5 mA
		50 mA

* Lead wire length — Auto switch connection side 0.5 m
Load connection side 0.5 m



Contact Protection Box Internal Circuit

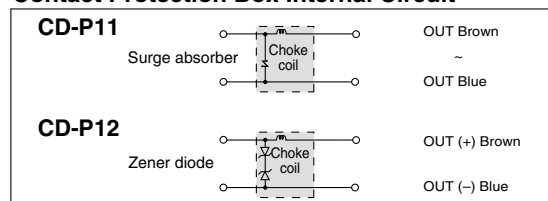

Contact Protection Box/Dimensions

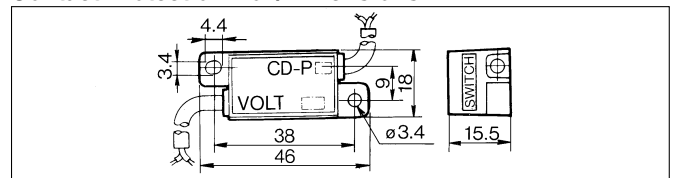

Contact Protection Box Connection

To connect a switch unit to a contact protection box, connect the lead wire from the side of the contact protection box marked SWITCH to the lead wire coming out of the switch unit. Keep the switch as close as possible to the contact protection box, with a lead wire length of no more than 1 meter.

Prior to Use

Auto Switches Connection and Example

Basic Wiring

Solid state 3-wire, NPN

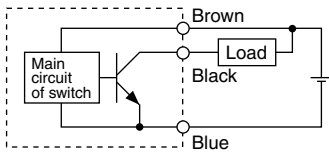

Solid state 3-wire, PNP

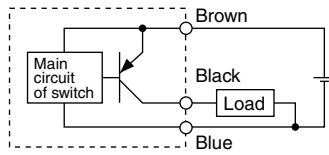

2-wire (Solid state)

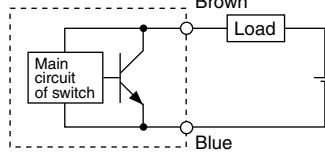

2-wire (Reed)

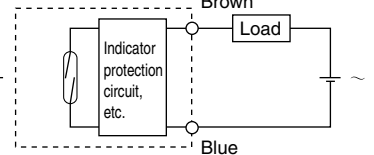

(Power supply for switch and load are separate.)

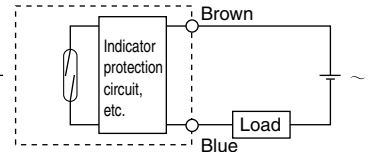
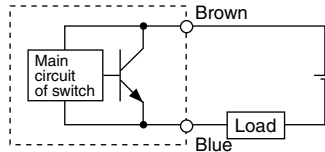
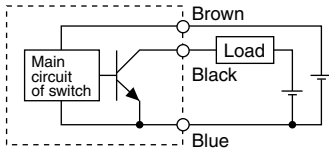

Example of Connection with PLC (Programmable Logic Controller)

• Sink input specifications 3-wire, NPN

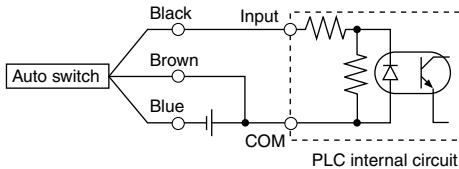

• Source input specifications 3-wire, PNP

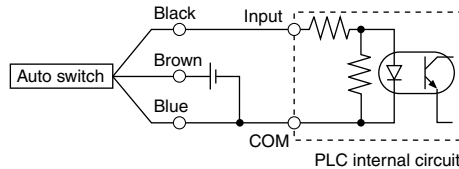

Connect according to the applicable PLC input specifications, as the connection method will vary depending on the PLC input specifications.

2-wire

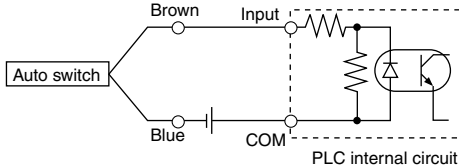

2-wire

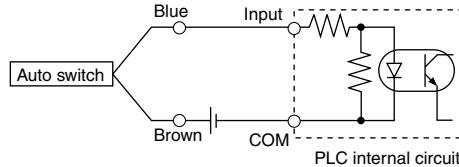

Example of AND (Series) and OR (Parallel) Connection

• 3-wire

AND connection for NPN output (Using relays)

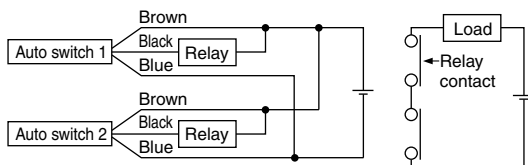

AND connection for NPN output (Performed with auto switches only)

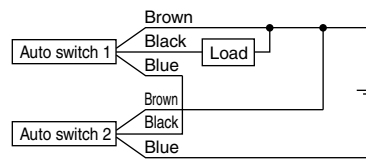

OR connection for NPN output

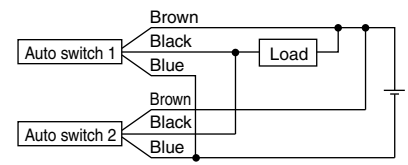

The indicator lights will light up when both auto switches are turned ON.

• 2-wire

2-wire with 2-switch AND connection

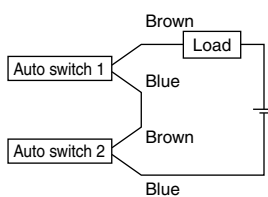

When two auto switches are connected in series, a load may malfunction because the load voltage will decline when in the ON state. The indicator lights will light up when both of the auto switches are in the ON state.

Load voltage at ON = Power supply voltage – Residual voltage x 2 pcs.
= 24 V – 4 V x 2 pcs.
= 16 V

Example: Power supply is 24 VDC
Internal voltage drop in auto switch is 4 V.

2-wire with 2-switch OR connection

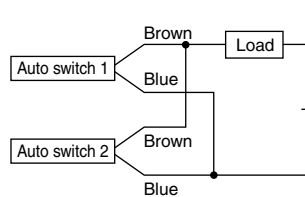

(Solid state)
When two auto switches are connected in parallel, malfunction may occur because the load voltage will increase when in the OFF state.

Load voltage at OFF = Leakage current x 2 pcs. x Load impedance
= 1 mA x 2 pcs. x 3 kΩ
= 6 V

Example: Load impedance is 3 kΩ.
Leakage current from auto switch is 1 mA.

(Reed)
Because there is no current leakage, the load voltage will not increase when turned OFF. However, depending on the number of auto switches in the ON state, the indicator lights may sometimes grow dim or not light up, due to the dispersion and reduction of the current flowing to the auto switches.

Solid State Auto Switch Direct Mounting Style D-M9N(V)/D-M9P(V)/D-M9B(V)

 Refer to SMC website for the details of the products conforming to the international standards.

Auto Switch Specifications

PLC: Programmable Logic Controller

D-M9□, D-M9□V (With indicator light)						
Auto switch model	D-M9N	D-M9NV	D-M9P	D-M9PV	D-M9B	D-M9BV
Electrical entry direction	In-line	Perpendicular	In-line	Perpendicular	In-line	Perpendicular
Wiring type	3-wire				2-wire	
Output type	NPN		PNP		—	
Applicable load	IC circuit, Relay, PLC				24 VDC relay, PLC	
Power supply voltage	5, 12, 24 VDC (4.5 to 28 V)				—	
Current consumption	10 mA or less				—	
Load voltage	28 VDC or less		—		24 VDC (10 to 28 VDC)	
Load current	40 mA or less				2.5 to 40 mA	
Internal voltage drop	0.8 V or less at 10 mA (2 V or less at 40 mA)				4 V or less	
Leakage current	100 μA or less at 24 VDC				0.8 mA or less	
Indicator light	Red LED illuminates when turned ON.					
Standard	CE marking					

- Lead wires — Oilproof flexible heavy-duty vinyl cord: $\phi 2.7 \times 3.2$ ellipse, 0.15 mm², 2 cores (D-M9B(V)), 3 cores (D-M9N(V), D-M9P(V))

Note 1) Refer to page 8 for solid state auto switch common specifications.

Note 2) Refer to page 8 for lead wire lengths.

Grommet

- 2-wire load current is reduced (2.5 to 40 mA).
- Flexibility is 1.5 times greater than the conventional model (SMC comparison).
- Using flexible cable as standard spec.



Caution

Precautions

Fix the auto switch with the existing screw installed on the auto switch body. The auto switch may be damaged if a screw other than the one supplied is used.

Auto Switch Internal Circuit

D-M9N(V)

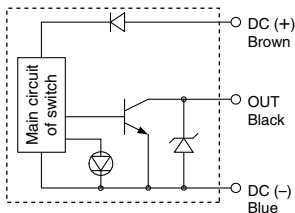

D-M9P(V)

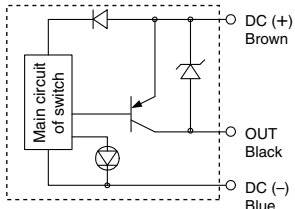

D-M9B(V)

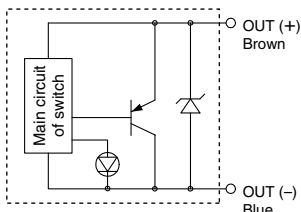

Weight

(g)

Auto switch model	D-M9N(V)	D-M9P(V)	D-M9B(V)	
Lead wire length (m)	0.5	8	8	7
	1	14	14	13
	3	41	41	38
	5	68	68	63

Dimensions

(mm)

D-M9□

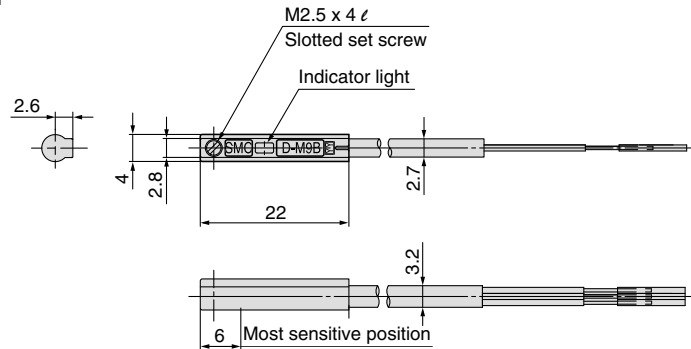

D-M9□V

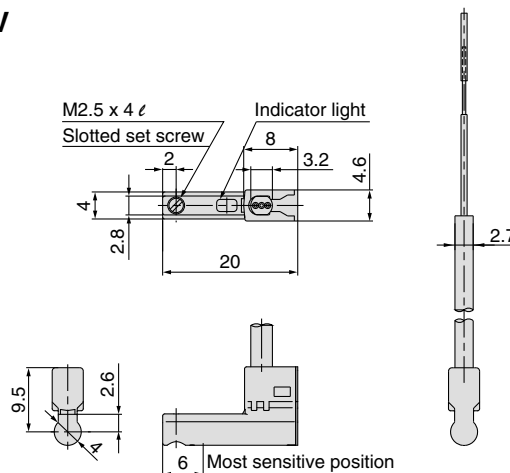

2-Color Indication Solid State Auto Switch Direct Mounting Style

D-M9NW(V)/D-M9PW(V)/D-M9BW(V)



Refer to SMC website for the details of the products conforming to the international standards.

Auto Switch Specifications

PLC: Programmable Logic Controller

D-M9□W, D-M9□WV (With indicator light)						
Auto switch model	D-M9NW	D-M9NWV	D-M9PW	D-M9PWV	D-M9BW	D-M9BWV
Electrical entry direction	In-line	Perpendicular	In-line	Perpendicular	In-line	Perpendicular
Wiring type	3-wire				2-wire	
Output type	NPN		PNP		—	
Applicable load	IC circuit, Relay, PLC				24 VDC relay, PLC	
Power supply voltage	5, 12, 24 VDC (4.5 to 28 V)				—	
Current consumption	10 mA or less				—	
Load voltage	28 VDC or less		—		24 VDC (10 to 28 VDC)	
Load current	40 mA or less				2.5 to 40 mA	
Internal voltage drop	0.8 V or less at 10 mA (2 V or less at 40 mA)				4 V or less	
Leakage current	100 μA or less at 24 VDC				0.8 mA or less	
Indicator light	Operating position Red LED illuminates. Optimum operating position Green LED illuminates.					
Standard	CE marking					

Grommet

- 2-wire load current is reduced (2.5 to 40 mA).
- Flexibility is 1.5 times greater than the conventional model (SMC comparison).
- Using flexible cable as standard spec.
- The optimum operating position can be determined by the color of the light. (Red → Green ← Red)



Caution

Precautions

Fix the auto switch with the existing screw installed on the auto switch body. The auto switch may be damaged if a screw other than the one supplied is used.

- Lead wires — Oilproof flexible heavy-duty vinyl cord: $\phi 2.7 \times 3.2$ ellipse, 0.15 mm², 2 cores (D-M9BW(V)), 3 cores (D-M9NW(V), D-M9PW(V))

Note 1) Refer to page 8 for solid state auto switch common specifications.

Note 2) Refer to page 8 for lead wire lengths.

Weight

(g)

Auto switch model	D-M9NW(V)	D-M9PW(V)	D-M9BW(V)	
Lead wire length (m)	0.5	8	8	7
	1	14	14	13
	3	41	41	38
	5	68	68	63

Auto Switch Internal Circuit

D-M9NW(V)

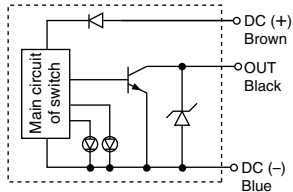

D-M9PW(V)

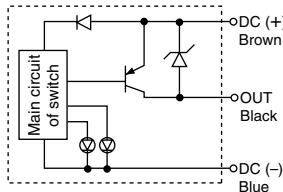

D-M9BW(V)

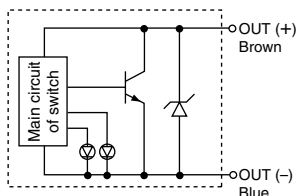

Indicator light/Display method

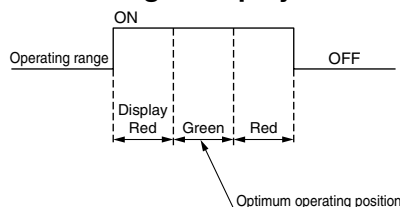

Dimensions

(mm)

D-M9□W

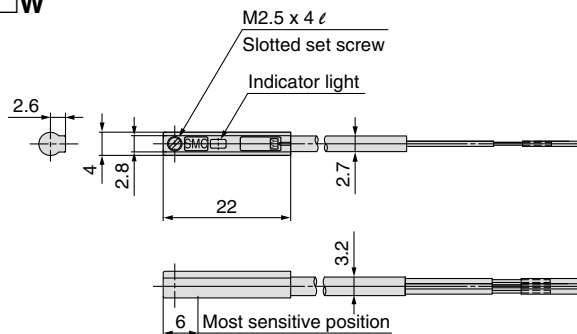

D-M9□WV

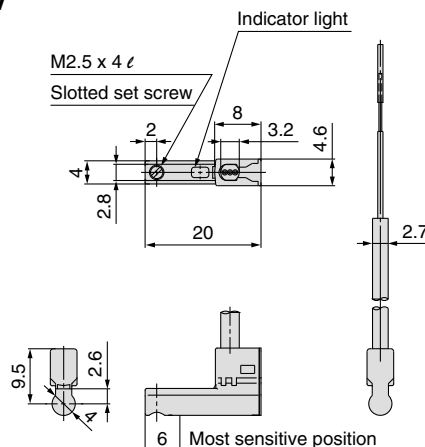

Reed Auto Switch Direct Mounting Style

D-A90(V)/D-A93(V)/D-A96(V)



Refer to SMC website for the details of the products conforming to the international standards.

Auto Switch Specifications

PLC: Programmable Logic Controller

Grommet



Caution

Precautions

Fix the auto switch with the existing screw installed on the auto switch body. The auto switch may be damaged if a screw other than the one supplied is used.

Auto Switch Internal Circuit

D-A90(V)

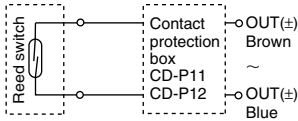

D-A93(V)

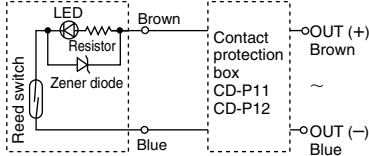

D-A96(V)

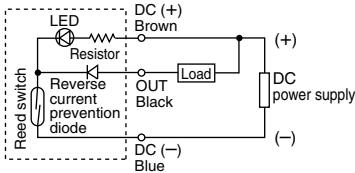

Note 1) Operating load is an induction load.
Note 2) Wiring to the load is 5 m or longer.
Note 3) Load voltage is 100 VAC.
Use the contact protection box in any of the above listed situations. The contact point life may decrease. (Refer to page 9 for contact protection box.)

D-A90, D-A90V (Without indicator light)			
Auto switch model	D-A90, D-A90V		
Applicable load	IC circuit, Relay, PLC		
Load voltage	24 V _{AC} or less	48 V _{AC} or less	100 V _{AC} or less
Maximum load current	50 mA	40 mA	20 mA
Contact protection circuit	None		
Internal resistance	1 Ω or less (Including lead wire length of 3 m)		
Standard	CE marking		
D-A93, D-A93V, D-A96, D-A96V (With indicator light)			
Auto switch model	D-A93, D-A93V		D-A96, D-A96V
Applicable load	Relay, PLC		IC circuit
Load voltage	24 VDC	100 VAC	4 to 8 VDC
Load current range and Maximum load current	5 to 40 mA	5 to 20 mA	20 mA
Contact protection circuit	None		
Internal voltage drop	D-A93: 2.4 V or less (up to 20 mA)/3 V or less (up to 40 mA) D-A93V: 2.7 V or less		0.8 V or less
Indicator light	Red LED illuminates when turned ON.		
Standard	CE marking		

Lead wires

D-A90(V)/D-A93(V) — Oilproof heavy-duty vinyl cord, $\phi 2.7$, 0.18 mm² x 2 cores (Brown, Blue), 0.5 m
D-A96(V) — Oilproof heavy-duty vinyl cord, $\phi 2.7$, 0.15 mm² x 3 cores (Brown, Black, Blue), 0.5 m

Note 1) Refer to page 8 for reed auto switch common specifications.

Note 2) Refer to page 8 for lead wire lengths.

Note 3) Under 5 mA, the strength of the indicator light is poor. In some cases, visibility of the indicator light will not be possible where the output signal is less than 2.5 mA. However, there is no problem in terms of contact output, when an output signal exceeds 1 mA or more.

Weight

(g)

Model	D-A90	D-A90V	D-A93	D-A93V	D-A96	D-A96V
Lead wire length (m)	0.5	6	6	6	8	8
	3	30	30	30	41	41

Dimensions

(mm)

D-A90/D-A93/D-A96

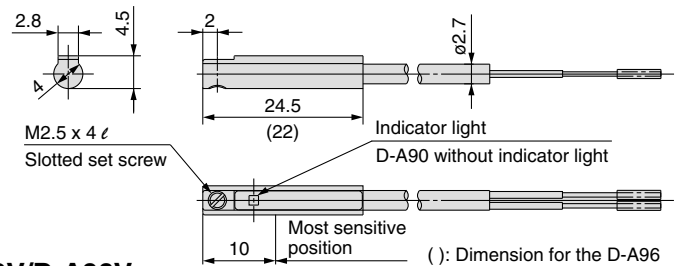

D-A90V/D-A93V/D-A96V

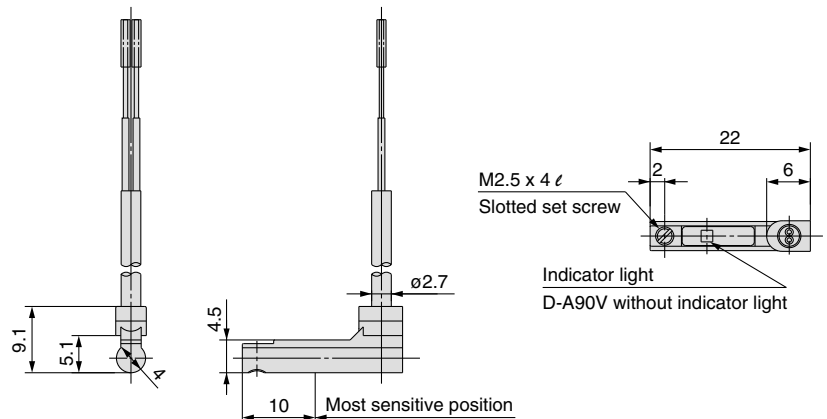





Safety Instructions

These safety instructions are intended to prevent hazardous situations and/or equipment damage. These instructions indicate the level of potential hazard with the labels of “**Caution,**” “**Warning**” or “**Danger.**” They are all important notes for safety and must be followed in addition to International Standards (ISO/IEC)*1), and other safety regulations.

- *1) ISO 4414: Pneumatic fluid power – General rules relating to systems.
- ISO 4413: Hydraulic fluid power – General rules relating to systems.
- IEC 60204-1: Safety of machinery – Electrical equipment of machines. (Part 1: General requirements)
- ISO 10218-1: Manipulating industrial robots - Safety.
- etc.

-  **Caution:** **Caution** indicates a hazard with a low level of risk which, if not avoided, could result in minor or moderate injury.
-  **Warning:** **Warning** indicates a hazard with a medium level of risk which, if not avoided, could result in death or serious injury.
-  **Danger :** **Danger** indicates a hazard with a high level of risk which, if not avoided, will result in death or serious injury.

Warning

- 1. The compatibility of the product is the responsibility of the person who designs the equipment or decides its specifications.**

Since the product specified here is used under various operating conditions, its compatibility with specific equipment must be decided by the person who designs the equipment or decides its specifications based on necessary analysis and test results. The expected performance and safety assurance of the equipment will be the responsibility of the person who has determined its compatibility with the product. This person should also continuously review all specifications of the product referring to its latest catalog information, with a view to giving due consideration to any possibility of equipment failure when configuring the equipment.
- 2. Only personnel with appropriate training should operate machinery and equipment.**

The product specified here may become unsafe if handled incorrectly. The assembly, operation and maintenance of machines or equipment including our products must be performed by an operator who is appropriately trained and experienced.
- 3. Do not service or attempt to remove product and machinery/equipment until safety is confirmed.**
 1. The inspection and maintenance of machinery/equipment should only be performed after measures to prevent falling or runaway of the driven objects have been confirmed.
 2. When the product is to be removed, confirm that the safety measures as mentioned above are implemented and the power from any appropriate source is cut, and read and understand the specific product precautions of all relevant products carefully.
 3. Before machinery/equipment is restarted, take measures to prevent unexpected operation and malfunction.
- 4. Contact SMC beforehand and take special consideration of safety measures if the product is to be used in any of the following conditions.**
 1. Conditions and environments outside of the given specifications, or use outdoors or in a place exposed to direct sunlight.
 2. Installation on equipment in conjunction with atomic energy, railways, air navigation, space, shipping, vehicles, military, medical treatment, combustion and recreation, or equipment in contact with food and beverages, emergency stop circuits, clutch and brake circuits in press applications, safety equipment or other applications unsuitable for the standard specifications described in the product catalog.
 3. An application which could have negative effects on people, property, or animals requiring special safety analysis.
 4. Use in an interlock circuit, which requires the provision of double interlock for possible failure by using a mechanical protective function, and periodical checks to confirm proper operation.



Safety Instructions

Caution

1. The product is provided for use in manufacturing industries.

The product herein described is basically provided for peaceful use in manufacturing industries.

If considering using the product in other industries, consult SMC beforehand and exchange specifications or a contract if necessary.

If anything is unclear, contact your nearest sales branch.

Limited warranty and Disclaimer/Compliance Requirements

The product used is subject to the following “Limited warranty and Disclaimer” and “Compliance Requirements”. Read and accept them before using the product.

Limited warranty and Disclaimer

1. The warranty period of the product is 1 year in service or 1.5 years after the product is delivered.*2)

Also, the product may have specified durability, running distance or replacement parts. Please consult your nearest sales branch.

2. For any failure or damage reported within the warranty period which is clearly our responsibility, a replacement product or necessary parts will be provided.

This limited warranty applies only to our product independently, and not to any other damage incurred due to the failure of the product.

3. Prior to using SMC products, please read and understand the warranty terms and disclaimers noted in the specified catalog for the particular products.

***2) Vacuum pads are excluded from this 1 year warranty.**

A vacuum pad is a consumable part, so it is warranted for a year after it is delivered.

Also, even within the warranty period, the wear of a product due to the use of the vacuum pad or failure due to the deterioration of rubber material are not covered by the limited warranty.

Compliance Requirements

1. The use of SMC products with production equipment for the manufacture of weapons of mass destruction (WMD) or any other weapon is strictly prohibited.

2. The exports of SMC products or technology from one country to another are governed by the relevant security laws and regulations of the countries involved in the transaction. Prior to the shipment of a SMC product to another country, assure that all local rules governing that export are known and followed.



Series CVQM

Specific Product Precautions

Be sure to read before handling.

Refer to back pages 1 and 2 for Safety Instructions, "Handling Precautions for SMC Products" (M-E03-3) for Actuators and Auto Switches Precautions.

Mounting

Others

⚠ Warning

1. Do not put hands or fingers between the plate and cylinder tubing.

Never put hands or fingers in the gap between the plate and cylinder tubing when the piston rods are retracted. Due to the heavy power output of the cylinder, failure to comply with this directive may result in trapping and subsequent injury to the human body.

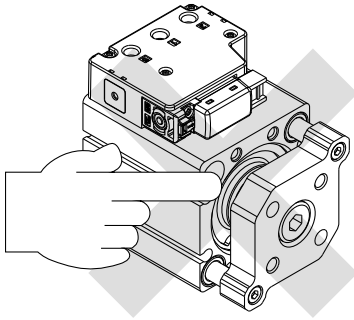

⚠ Caution

1. Do not scratch or dent the sliding parts of the piston rod and guide rods.

Damage to seals may cause air leakage or faulty operation.

2. Mounting of work piece

When screwing a bolt onto the threaded portion of the plate surface, be certain that the guide rods are fully extended to the end. Also, be careful that the tightening torque is not applied to the guide rods.

3. Make sure that the cylinder mounting surface has a flatness of 0.02 mm or less.

When mounting the cylinder body or work pieces on the plate, improper flatness of the mounting surface may cause malfunctions.

When the flatness of a work piece is not sufficient, attaching a shim such as a flat washer, etc., at the place of a mounting bolt between the work piece and the plate may reduce the affect on the operation.

⚠ Caution

1. Do not separate the cylinder from the valve.
2. This product should not be used as a stopper.
3. Do not disassemble and modify the product.
4. For example, in a pressing application, the cylinder thrust is directly applied to the plate, therefore, make sure that the pressing force is applied to the plate directly on the extended axial line of a rod. (Below figures)

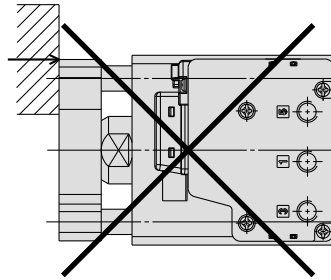
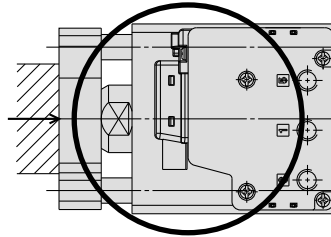

SMC'S GLOBAL MANUFACTURING, DISTRIBUTION AND SERVICE NETWORK

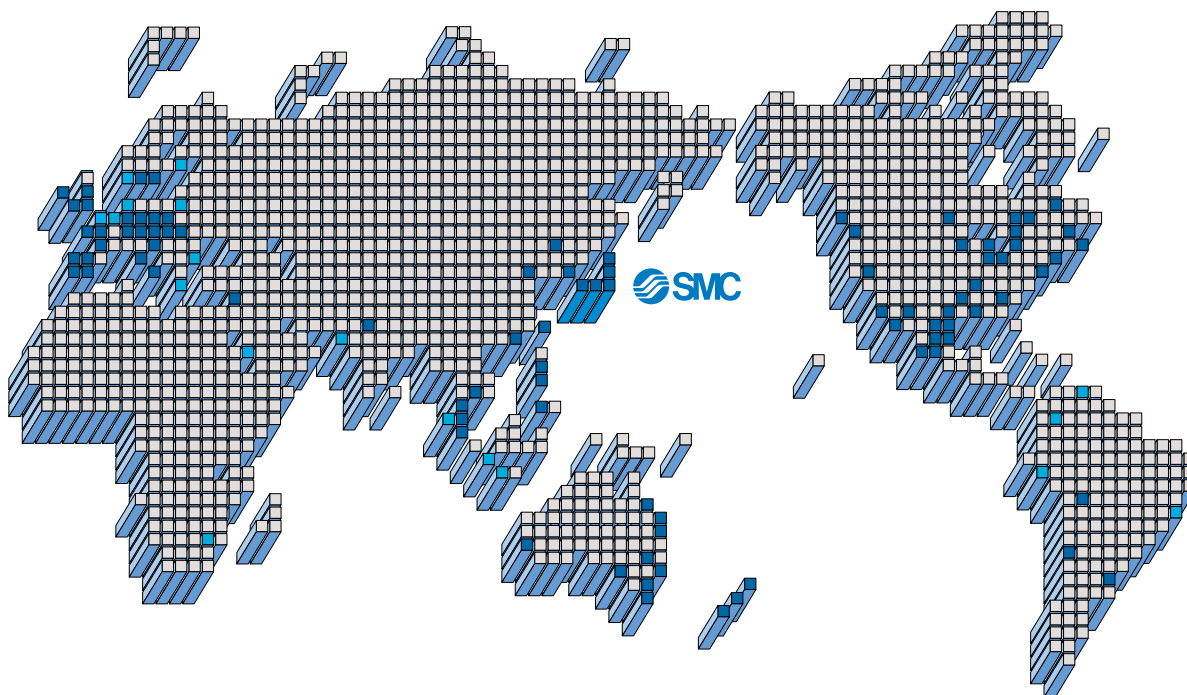

EUROPE

AUSTRIA

SMC Pneumatik GmbH (Austria)

BELGIUM

SMC Pneumatics N.V./S.A.

BULGARIA

SMC Industrial Automation Bulgaria Eood

CROATIA

SMC Industrijska Automatika d.o.o.

CZECH REPUBLIC

SMC Industrial Automation CZ s.r.o.

DENMARK

SMC Pneumatik A/S

ESTONIA

SMC Pneumatics Estonia OÜ

FINLAND

SMC Pneumatics Finland Oy

FRANCE

SMC Pneumatique SA

GERMANY

SMC Pneumatik GmbH

GREECE

SMC Hellas E.P.E.

HUNGARY

SMC Hungary Ipari Automatizálási Kft.

IRELAND

SMC Pneumatics (Ireland) Ltd.

ITALY

SMC Italia S.p.A.

LATVIA

SMC Pnuematics Latvia SIA

LITHUANIA

UAB "SMC Pneumatics"

NETHERLANDS

SMC Pneumatics B.V.

NORWAY

SMC Pneumatics Norway AS

POLAND

SMC Industrial Automation Polska Sp.z.o.o.

ROMANIA

SMC Romania S.r.l.

RUSSIA

SMC Pneumatik LLC

SLOVAKIA

SMC Priemyselná Automatizácia Spol s.r.o.

SLOVENIA

SMC Industrijska Avtomatika d.o.o.

SPAIN/PORTUGAL

SMC España S.A.

SWEDEN

SMC Pneumatics Sweden AB

SWITZERLAND

SMC Pneumatik AG

U.K.

SMC Pneumatics (U.K.) Ltd.

ASIA

CHINA

SMC (China) Co., Ltd.

HONG KONG

SMC Pneumatics (Hong Kong) Ltd.

INDIA

SMC Pneumatics (India) Pvt. Ltd.

MALAYSIA

SMC Pneumatics (S.E.A.) Sdn. Bhd.

PHILIPPINES

Shoketsu SMC Corporation

SINGAPORE

SMC Pneumatics (S.E.A.) Pte. Ltd.

SOUTH KOREA

SMC Pneumatics Korea Co., Ltd.

TAIWAN

SMC Pneumatics (Taiwan) Co., Ltd.

THAILAND

SMC (Thailand) Ltd.

NORTH AMERICA

CANADA

SMC Pneumatics (Canada) Ltd.

MEXICO

SMC Corporation (Mexico), S.A. de C.V.

U.S.A.

SMC Corporation of America

SOUTH AMERICA

ARGENTINA

SMC Argentina S.A.

BOLIVIA

SMC Pneumatics Bolivia S.r.l.

BRAZIL

SMC Pneumáticos do Brasil Ltda

CHILE

SMC Pneumatics (Chile) S.A.

VENEZUELA

SMC Neumatica Venezuela S.A.

OCEANIA

AUSTRALIA

SMC Pneumatics (Australia) Pty. Ltd.

NEW ZEALAND

SMC Pneumatics (N.Z.) Ltd.



Safety Instructions

Be sure to read "Handling Precautions for SMC Products" (M-E03-3) before using.

SMC Corporation

Akihabara UDX 15F,
4-14-1, Sotokanda, Chiyoda-ku, Tokyo 101-0021, JAPAN
Phone: 03-5207-8249 Fax: 03-5298-5362
URL <http://www.smcworld.com>
© 2009 SMC Corporation All Rights Reserved

Specifications are subject to change without prior notice
and any obligation on the part of the manufacturer.

D-DN

1st printing NT printing NT 6000SZ Printed in Japan.

This catalog is printed on recycled paper with concern for the global environment.