

3-Color Display

Digital Gap Checker



F type 0.01 to 0.03 mm
Rated distance range (Displayable/Settable range: 0 to 60)

G type 0.02 to 0.15 mm
Rated distance range (Displayable/Settable range: 10 to 300)

H type 0.05 to 0.30 mm
Rated distance range (Displayable/Settable range: 30 to 500)



Check at a glance if the workpiece is placed or not!

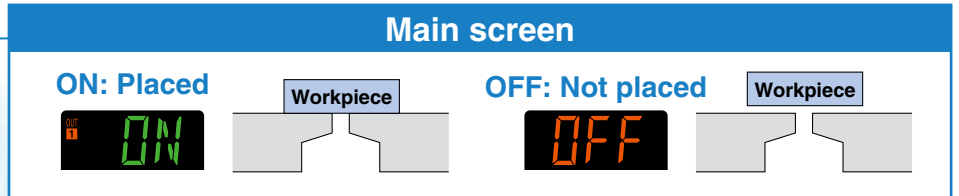
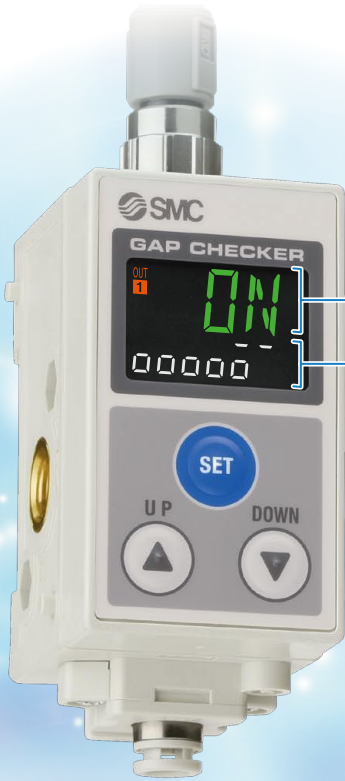

The clearance distance between the detection surface and the workpiece can be found intuitively!

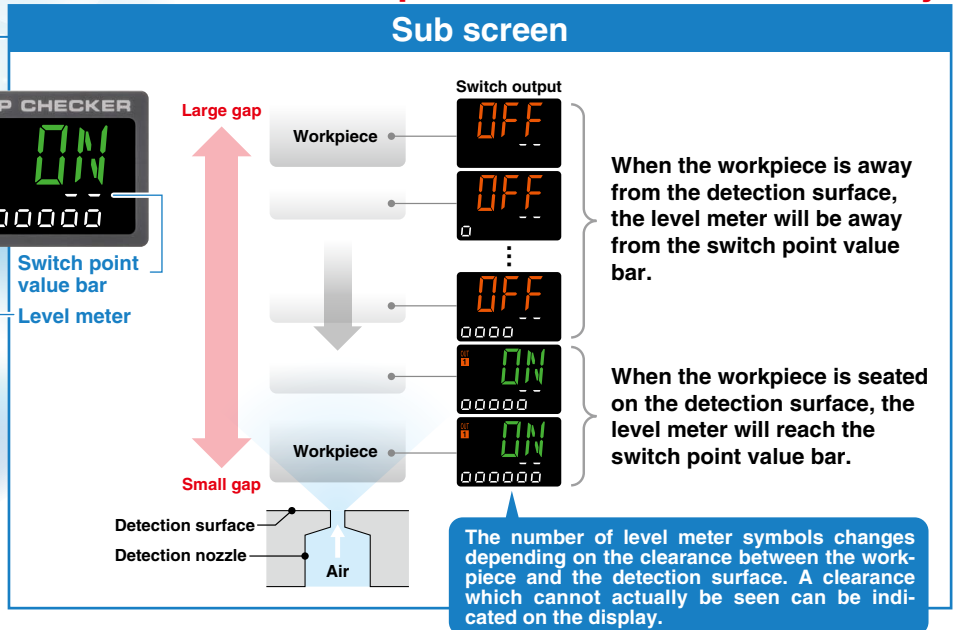

Simple Setting

Change the settings while checking the displayed value!

3 steps

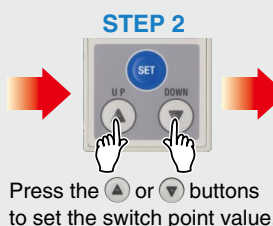
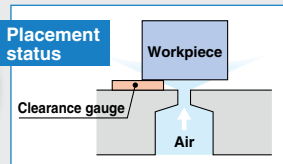

Snap shot function

Pressing the UP and DOWN buttons for a minimum of 1 second will make the switch point the same as the current displayed value!

Page 1

Energy Saving Page 2

• Air consumption: **60% reduction** *: For G type

Environmental Resistance Page 1

- Improved drainage resistance: **10 times or more**
*: Compared with the ISA2 based on the SMC's specific testing condition (oil proof test).
- Easier maintenance

ISA3 Series

Manifold Page 4

New Centralized lead wire (With control unit)



Centralized lead wire



CAT.ES100-105C

3 Step Setting (Switch Point Change Mode)

A simple operation to enter the switch point value (point at which the clearance reaches the switch point value)

Snap shot function
Pressing the ▲ and ▼ buttons for a minimum of 1 second, then releasing the buttons when the displayed switch point value disappears, will make the switch point the same as the current displayed value.

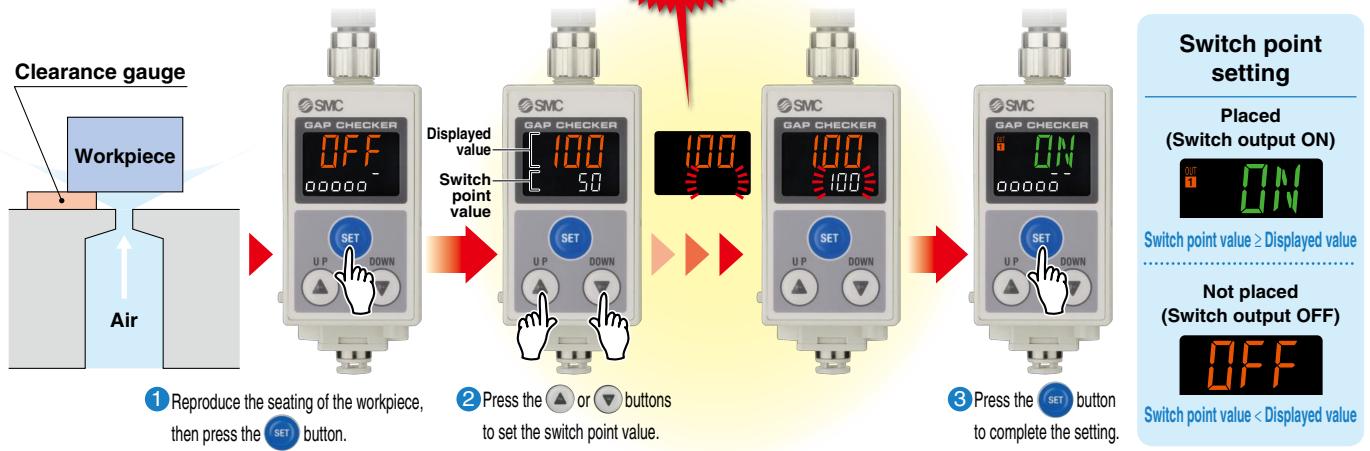

Features of the 2-Screen, 3-Color Digital Display

The seating condition can be checked at a glance. The sub screen display can be selected from 6 display options.

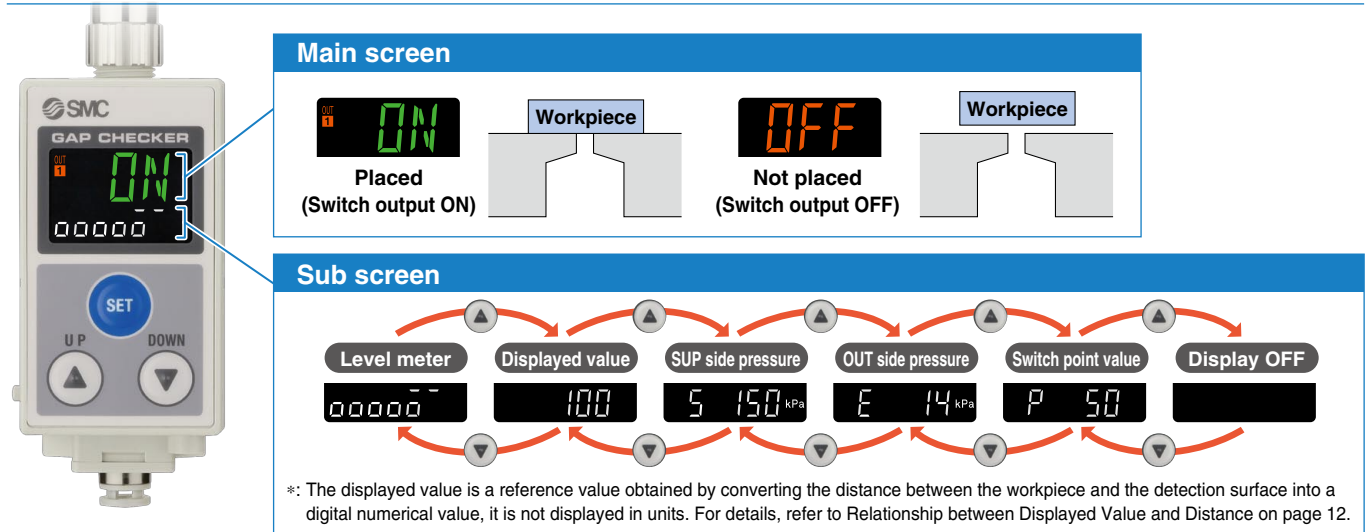

Improved Environmental Resistance

Easier maintenance

The internal orifice part can be removed for cleaning. It is not necessary to remove the piping or metal connection fitting for cleaning when the product is installed in the user's equipment.



*: If the orifice is taken out, perform the switch point setting again.

Measures against drainage

Drainage resistance: 10 times or more

*: Based on the SMC's specific testing condition (oil proof test).
*: Compared with the ISA2.

Withstand pressure expanded 3 times*1 compared with the ISA2

Max.: 600 kPa

*1: Compared with the ISA2 with 0.2 MPa pressure gauge.

High pressure flushing

*: The switch output will be OFF during flushing.

Noise reduction

Energy saving

Measures against clogging

A Exhaust noise
Zero

Noise reduction

The current model (ISA2) needs to exhaust air from the exhaust port due to the bridge circuit. The ISA3 does not exhaust air from the product body. This reduces noise considerably compared with the current model.

B Air consumption
60% reduction*1

Energy saving

The new detection principle eliminates air being exhausted from the product. This makes the flow consumption 0 L/min. when the workpiece is seated.

A much lower air consumption is required than the current model.

*1: Conditions: Unseated for 5 seconds and seated for 20 seconds (For G type)

Comparison of detection circuit

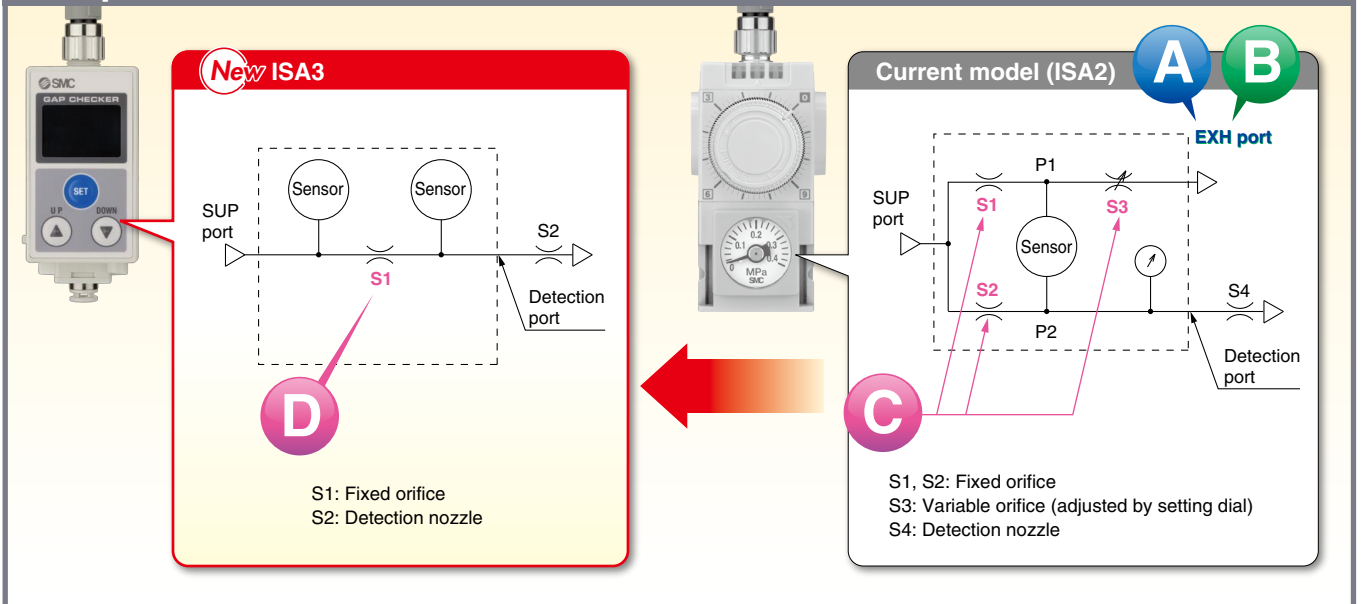

C Number of orifices
3 → 1

Measures against clogging

By reducing the number of internal orifices from 3 to 1, there is less possibility of variations in the output due to clogging. By removing the setting dial for S3, variations in the detection distance are prevented.

D Orifice area ratio
68% increase*1

Measures against clogging

A larger orifice area provides less possibility of clogging. Even if the orifice is clogged with foreign matter, the product construction enables cleaning with the internal orifice removed.

*1: Except F type

Compact & Lightweight

Volume: **40% reduction**

Weight: **55% reduction**

(Comparison between the ISA3-GC and the current model ISA2 with One-touch fitting)

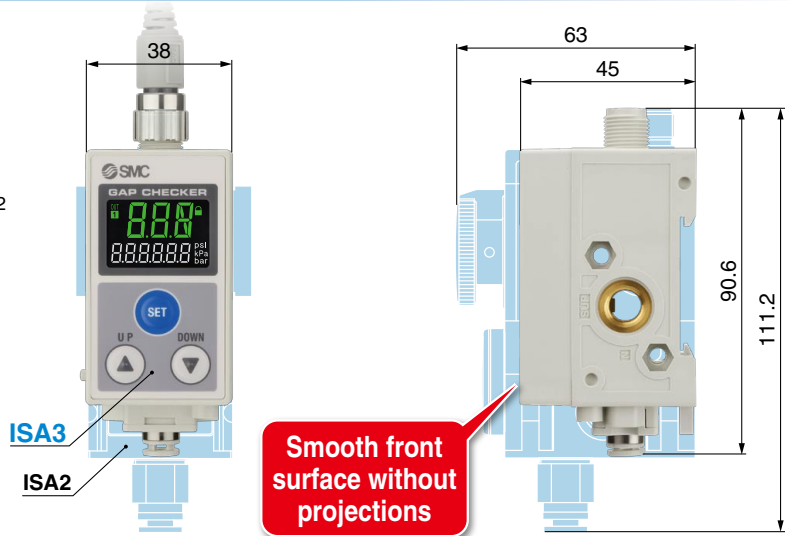

Space-saving & Reduction of Work-Hours (Centralized Lead Wire)

Installation space:
30 mm reduction

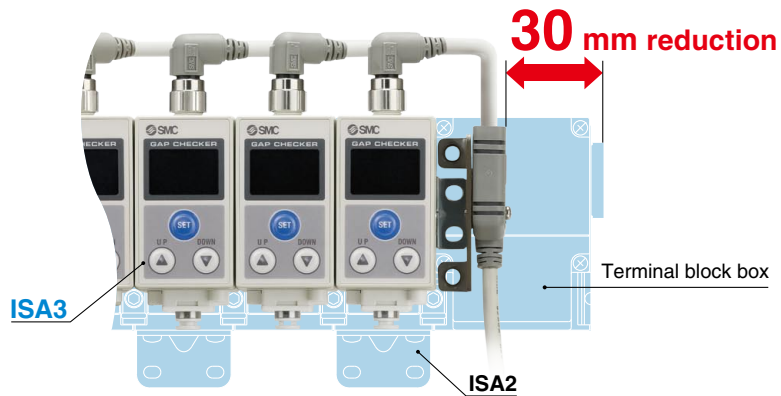

Requires less work-hours to wire.

Current model

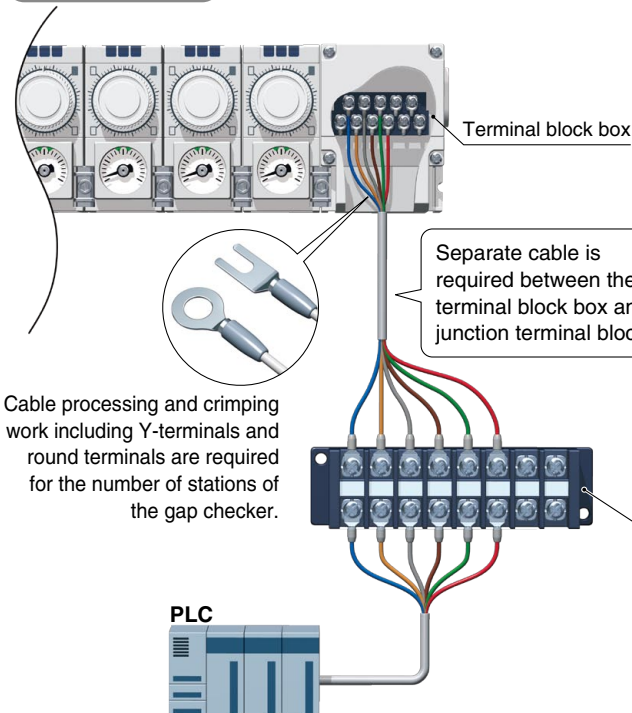

ISA3

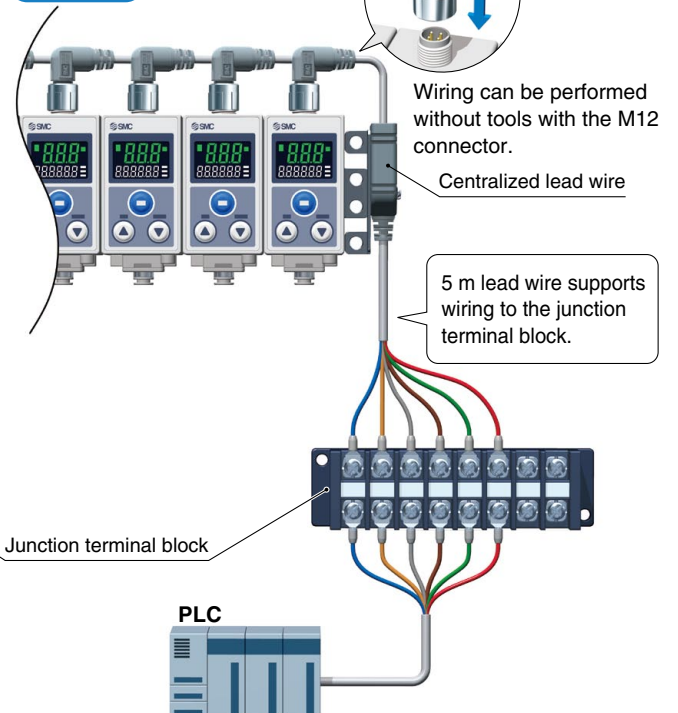

Keylock Function

A key LED turns ON when the product is locked and the button operation is disabled to prevent unintentional changes to set values.

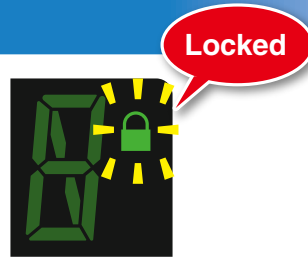

Piping Variations

Piping specification:
C type

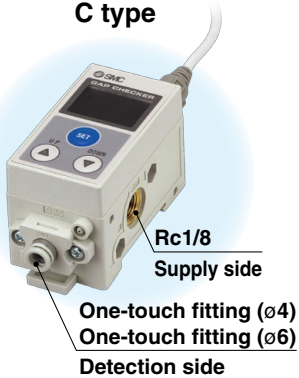

Piping specification:
F type



Mounting

Bracket



DIN rail



Manifold

With control unit



*: Bracket mounting only

Without control unit



Centralized lead wire



Centralized lead wire



*: The electrical entry of centralized lead wire for M12 connector is on the right side.

If the supply port on the right side is used, arrange the centralized lead wire so that it does not interfere with the control unit.

Application Examples

Confirmation of the reference plane for press fitting of a shaft

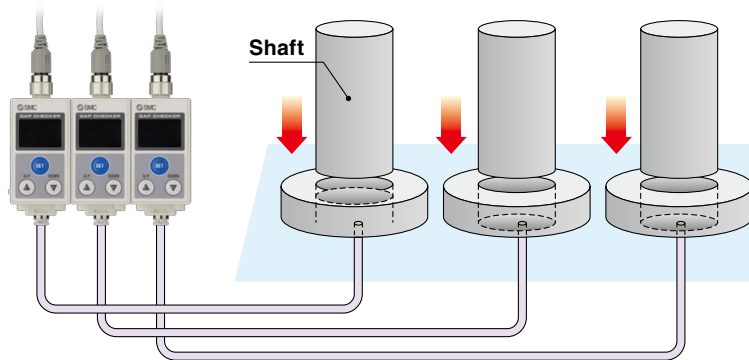

ON: Placed

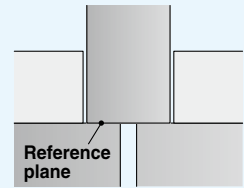

OFF: Not placed

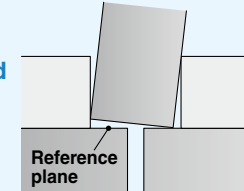

Confirmation of close contact with the reference plane for machining

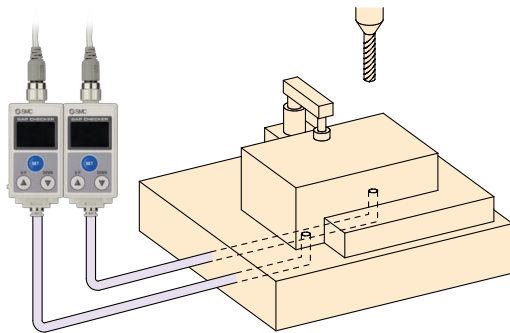

Confirmation of close contact with the workpiece for machining

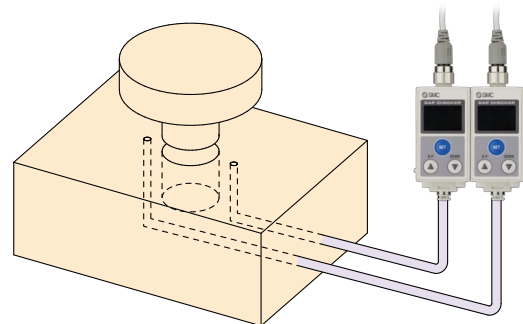

Main Functions

Display OFF mode

Display OFF mode can be selected. The display can be turned OFF to reduce power consumption.



Security code

By activating the security code, the key lock cannot be released without entering a security code.



Security code:
Input an arbitrary 3-digit value.

Display color

The color of the main display can be set to change depending upon the output activity. The display color change makes visual identification of the output ON/OFF easier.

When ON: Green	When OFF: Orange
When ON: Orange	When OFF: Green
Normally: Orange	
Normally: Green	

Unit selection

The pressure unit displayed on the sub screen can be changed.

Display unit	kPa	bar	psi
Smallest settable increment	1	0.01	0.1

Displayed value compensation

The displayed value can be corrected within $\pm 20\%$ R.D. of the displayed value at the time of shipment.

Forced output

The output can be fixed to an ON/OFF state when starting the system or during maintenance. This enables confirmation of the wiring and prevents system errors due to unexpected output.

Zero-clear of pressure display

The pressure value displayed on the sub screen can be cleared to zero.

CONTENTS

ISA3 Series

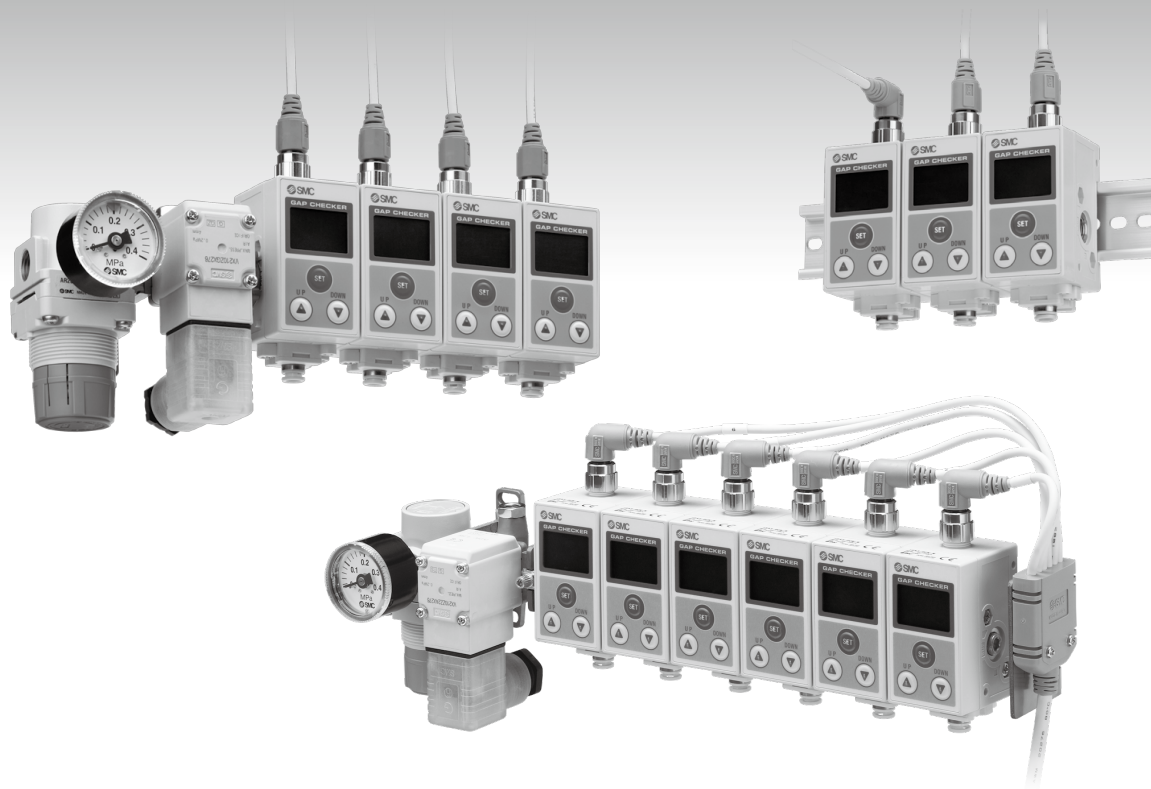

● 3-Color Display Digital Gap Checker ISA3 Series

How to Order (Without Control Unit)	Page 7
How to Order (With Control Unit).....	Page 8
Specifications	Page 9
Supply Pressure Dependence Characteristics	Page 10
Response Time	Page 11
Relationship between Displayed Value and Distance	Page 12
Nozzle Shape	Page 12
Internal Circuit and Wiring Example.....	Page 12
Construction Diagram	Page 13, 14
Parts List	Page 15, 16
Dimensions	Page 17 to 20
Error Indication.....	Page 21
Relationship between Supply Pressure and Display.....	Page 21

3-Color Display Digital Gap Checker Without Control Unit *ISA3 Series*



How to Order

ISA3-GCN-M2

Rated distance range

F	0.01 to 0.03 mm
G	0.02 to 0.15 mm
H	0.05 to 0.30 mm

Piping specifications

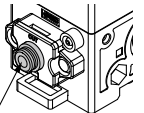
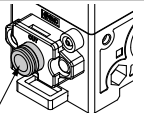
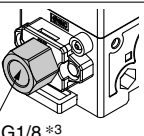
	Supply side	Detection side
C	Rc1/8	 ø4 One-touch fitting *1
		 ø6 One-touch fitting *2
F	G1/8 *3	 G1/8 *3

- *1: When F is selected for the rated distance range.
- *2: When G or H is selected for the rated distance range.
- *3: Conforming to ISO1179-1

Output specifications

N	NPN output
P	PNP output

Unit specifications of pressure value

Nil	With unit selection function *9
M	Fixed SI unit *10

- *9: Under the New Measurement Act, sales of digital gap checkers with the unit selection function have not been allowed for use in Japan.
- *10: Unit: kPa

Stations

1	1 station
2	2 stations
3	3 stations
4	4 stations
5	5 stations
6	6 stations

Option 1 (Cable)

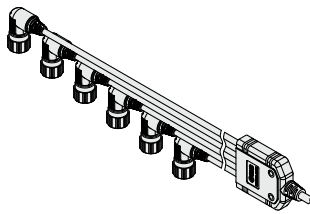
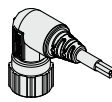
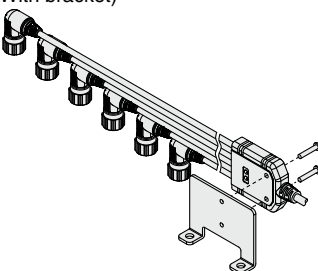
Nil	Straight *5 *6 	S	Centralized lead wire (Lead wire only) *4 *5 
	Right angle *5 *6 		Centralized lead wire (With bracket) *4 *5 
L		T	
N	None		

- *4: Cannot be selected for 1 station. One set is provided per manifold. A centralized lead wire is provided with M12 connectors for the number of stations. Refer to page 19 for details.
- *5: At the factory, the options are not attached to the product, but packed together with it for shipment.
- *6: Cables are provided for the number of stations.

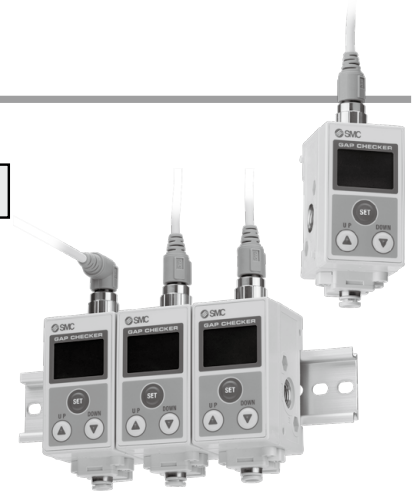

Option 2 (Bracket)

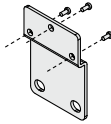
Nil	None (DIN rail mounting) *7
B	With bracket *5 *8 

- *7: Order DIN rail separately. (Refer to page 15.)
- *8: About the number of brackets, 1 station: 1 piece is packed, 2 stations or more: 2 pieces are packed.

Bracket mounting position

2 stations
(Mount to 1st and 2nd stations)



n stations
(Mount to 1st and nth stations)

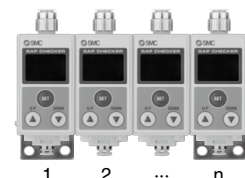

3-Color Display Digital Gap Checker With Control Unit

ISA3 Series



How to Order

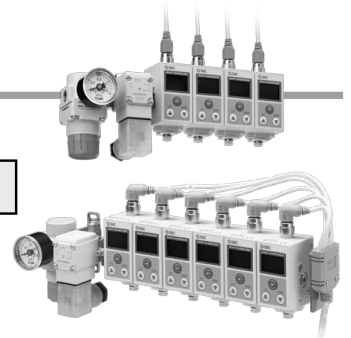

ISA3 - **G** **C** **N** - **M** **2** **B** - **L** **1**

Rated distance range

F	0.01 to 0.03 mm
G	0.02 to 0.15 mm
H	0.05 to 0.30 mm

Piping specifications

	Supply side	Detection side
C	Rc1/8	$\phi 4$ One-touch fitting *1
		$\phi 6$ One-touch fitting *2
F	G1/8 *3	G1/8 *3

*1: When F is selected for the rated distance range.

*2: When G or H is selected for the rated distance range.

*3: Conforming to ISO1179-1

Output specifications

N	NPN output
P	PNP output

Unit specifications of pressure value

Nil	With unit selection function *12
M	Fixed SI unit *13

*12: Under the New Measurement Act, sales of digital gap checkers with the unit selection function have not been allowed for use in Japan.

*13: Unit: kPa

Stations

1	1 station
2	2 stations
3	3 stations
4	4 stations
5	5 stations
6	6 stations

Option 1 (Cable)

Nil	Straight *5 *6 	S	Centralized lead wire (Lead wire only) *4 *5
L	Right angle *5 *6 		Centralized lead wire (With bracket) *4 *5
N	None	T	Centralized lead wire (With bracket) *4 *5

*4: Cannot be selected for 1 station. One set is provided per manifold. A centralized lead wire is provided with M12 connectors for the number of stations. Refer to page 19 for details.

*5: At the factory, the options are not attached to the product, but packed together with it for shipment.

*6: Cables are provided for the number of stations.

2 port solenoid valve Rated voltage

Nil	24 VDC
1 *11	100 VAC
2 *11	110 VAC

*11: Made to Order

Regulator (Refer to page 16.)

N *10	Without regulator
1	With regulator (AR-A), round type pressure gauge
2	With regulator (AR-B), square embedded type pressure gauge

*10: Made to Order

Control unit

L	Control unit (Supply port: Left side)
R	Control unit (Supply port: Right side)

Control unit piping specifications *8

Gap checker piping specifications	Supply port piping specifications
C	Rc1/4
F	G1/4 *9

*8: When the control unit is mounted, the piping specifications of the supply port will be changed due to piping specification of the gap checker.

*9: Conforming to ISO16030

Option 2 (Bracket)

B	With bracket *7
----------	---------------------

*7: The bracket for control unit is shipped mounted on the product.

ISA3 Series

For the Common Precautions for the Gap Checker, refer to Handling Precautions for SMC Products.
For the Specific Product Precautions, refer to the Operation Manual on the SMC website.

Specifications

Model		ISA3-F	ISA3-G	ISA3-H
Applicable fluid		Dry air (Filtered through a 5 µm filter)		
Rated distance range		0.01 to 0.03 mm	0.02 to 0.15 mm	0.05 to 0.30 mm
Displayable/Settable range (Distance reference) *1		0 to 60 *4	10 to 300 *4	30 to 500 *4
Minimum display unit (Distance reference) *1		1		
Rated pressure range		100 to 200 kPa		
Displayable range (Pressure value) *2		-20 to 220 kPa		
Withstand pressure		600 kPa		
Detection nozzle		ø1.5 *3		
Consumption flow rate		5 L/min or less	12 L/min or less	22 L/min or less
Power supply voltage		24 VDC ±10%, Ripple (p-p) 10% or less (With power supply polarity protection)		
Current consumption		25 mA or less		
Switch output		1 output (NPN or PNP)		
		Maximum load current	10 mA	
		Maximum applied voltage	26.4 V	
		Residual voltage	1 V or less (at 10 mA)	
		Short circuit protection	Provided	
Repeatability		0.005 mm	0.010 mm	0.020 mm
Temperature characteristics (Reference: 25°C)		0.010 mm	0.015 mm	0.030 mm
Hysteresis		0 to variable (Default: 3)	0 to variable (Default: 20)	
Display		2-screen display, LCD Main screen: 3-digit, 7-segment 2-color (Orange/Green) Sub screen: 6-digit, 7-segment 1-color (White)		
Environment		IP67 equivalent		
		Operating temperature range: Operating: 0 to 50°C, Stored: -20 to 70°C (No condensation or freezing)		
		Operating humidity range: Operating/stored: 35 to 85% RH (No condensation)		
		Withstand voltage: 1000 VAC or more (in 50/60 Hz) for 1 minute between terminals and housing		
		Insulation resistance: 2 MΩ or more (500 VDC measured via megohmmeter) between terminals and housing		
Piping specifications	For C type	Supply port	Rc1/8	
		Detection port	ø4 One-touch fitting	ø6 One-touch fitting
	For F type	Supply port	G1/8 (Conforming to ISO1179-1)	
		Detection port	G1/8 (Conforming to ISO1179-1)	
Cable	Lead wire with connector	M12 lead wire with 4 pin connector, 4 cores, ø4, 5 m Conductor O.D.: 0.72 mm, Insulator O.D.: 1.14 mm		
	Centralized lead wire	M12 lead wire with 4 pin connector part, 4 cores, ø4, Insulator O.D.: 1.14 mm Centralized lead wire part, 2 to 3 stations: 5 cores, ø4, 5 m, 4 to 6 stations: 8 cores, ø6, 5 m Conductor O.D.: 0.50 mm, Insulator O.D.: 1.00 mm (2 to 6 stations common)		
Weight		113 g (Cable not included, One-touch fitting)		
Standards		CE, RoHS compliant		

*1: For details, refer to Relationship between Displayed Value and Distance on page 12.

*2: The pressure value will be indicated on the sub screen.

*3: For details of the detection nozzle, refer to the figures on page 12.

*4: If hysteresis is set to 3 (Default setting), "Displayable/Settable range" of F type is limited to 57. If hysteresis is set to 20 (Default setting), G type is limited to 280 and H type is limited to 480.

Rated Distance Range and Displayable/Settable Range

⚠ Caution

The displayed value is a reference value obtained by converting the distance between the workpiece and the detection surface into a digital numerical value, it is not displayed in units.

For details, refer to Relationship between Displayed Value and Distance on page 12.

Rated distance range: Distance within which the product meets the specifications.

Displayable/Settable range: It is possible to display or set values, but it is not guaranteed to meet the specifications.

Model	Distance					
	0 mm	0.02 mm	0.05 mm	0.15 mm	0.30 mm	0.50 mm
ISA3-F type		■				
ISA3-G type		■	■			
ISA3-H type			■	■	■	

■ Rated distance range
■ Displayable/Settable range

Supply Pressure Dependence Characteristics

The distance for the product to turn ON varies depending on the supply pressure.

The graphs below show the variation of the distance for the product to turn ON, for 3 types of gap, by changing the supply pressure (± 50 kPa) when the product is set to turn ON at 150 kPa supply pressure.

Test conditions	Detection nozzle: $\phi 1.5$ Piping: F type $\phi 4 \times \phi 2.5$ tube/G, H type $\phi 6 \times \phi 4$ tube Reference pressure: 150 kPa
------------------------	--

*: Use within the rated pressure range (100 kPa to 200 kPa).

It will be impossible to measure the gap when the operating pressure is less than or equal to 80 kPa or more than 220 kPa. And the output will be OFF. (Refer to Relationship between Supply Pressure and Display on page 21.)

ISA3-F

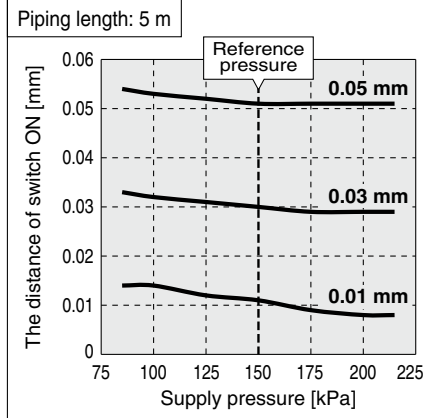
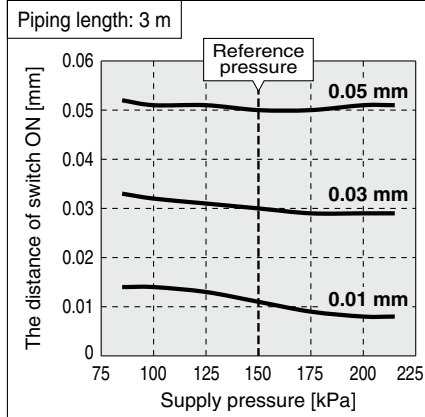
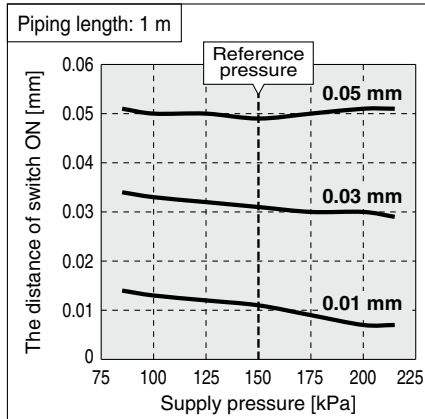

ISA3-G

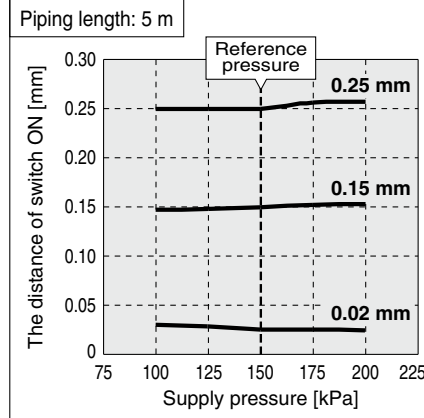
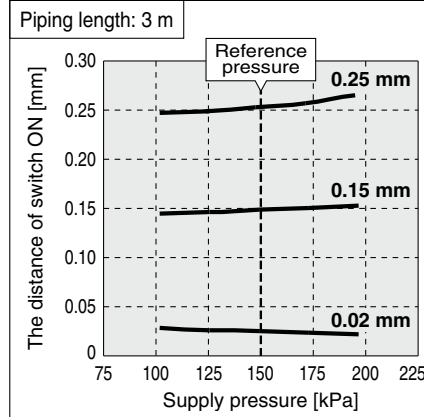
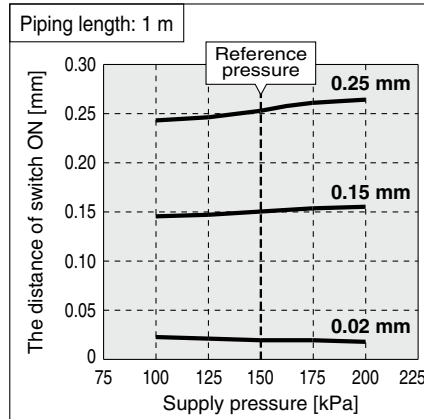

ISA3-H

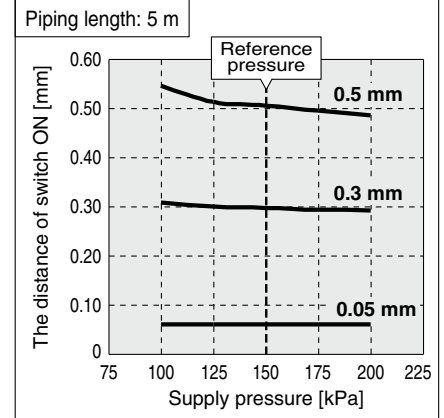
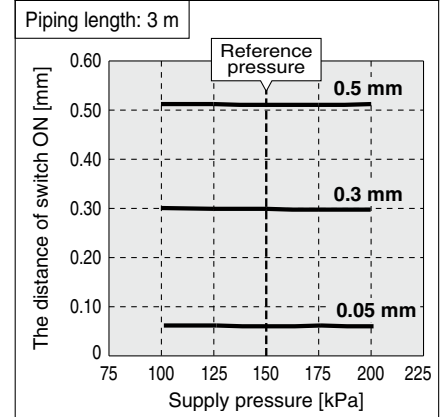
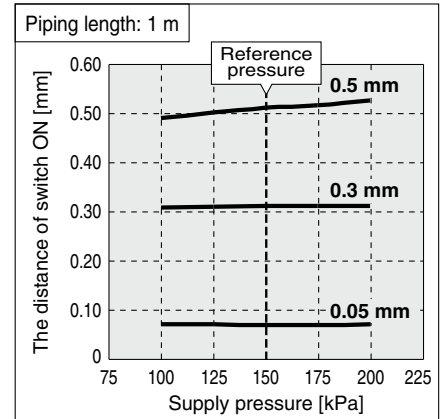

Response Time

Response time is the elapsed time between the pressure supply and the turning ON of the switch output.

The response time varies depending on the piping length from the OUT port to the detection nozzle, and the seating condition of the workpiece. The graphs below show the response time when the workpiece is approached at 90% distance and 0% distance (close contact). (*: The switch point is 100% distance.)

(Example: When the switch point is set to 0.1 mm, the response time when the workpiece is at 0.09 mm and 0 mm are measured.)

Test conditions	Detection nozzle: $\varnothing 1.5$ Piping: F type $\varnothing 4 \times \varnothing 2.5$ tube/G, H type $\varnothing 6 \times \varnothing 4$ tube Supply pressure: 200 kPa
------------------------	---

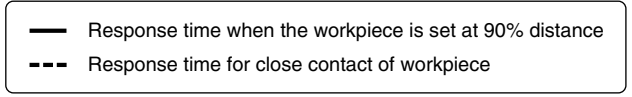

ISA3-F

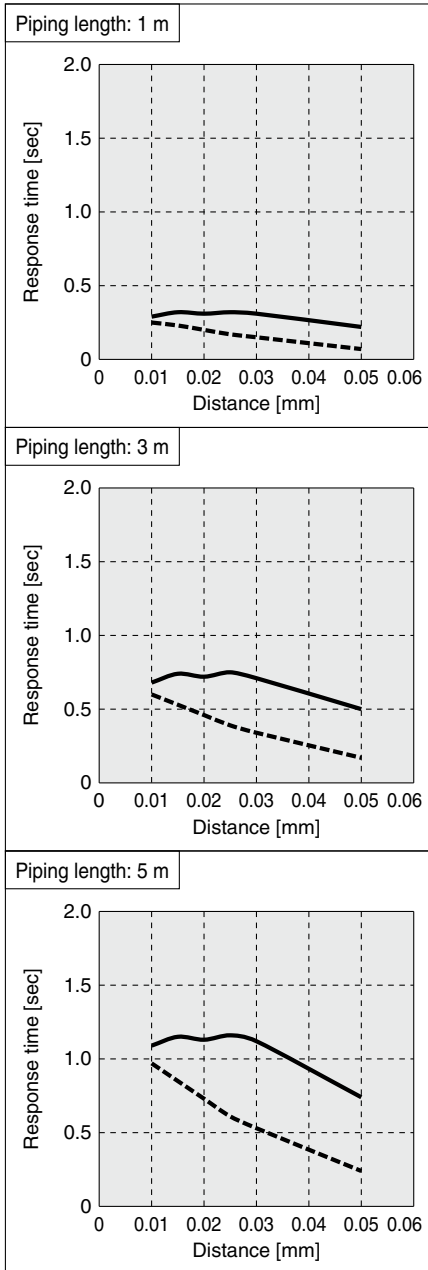

ISA3-G

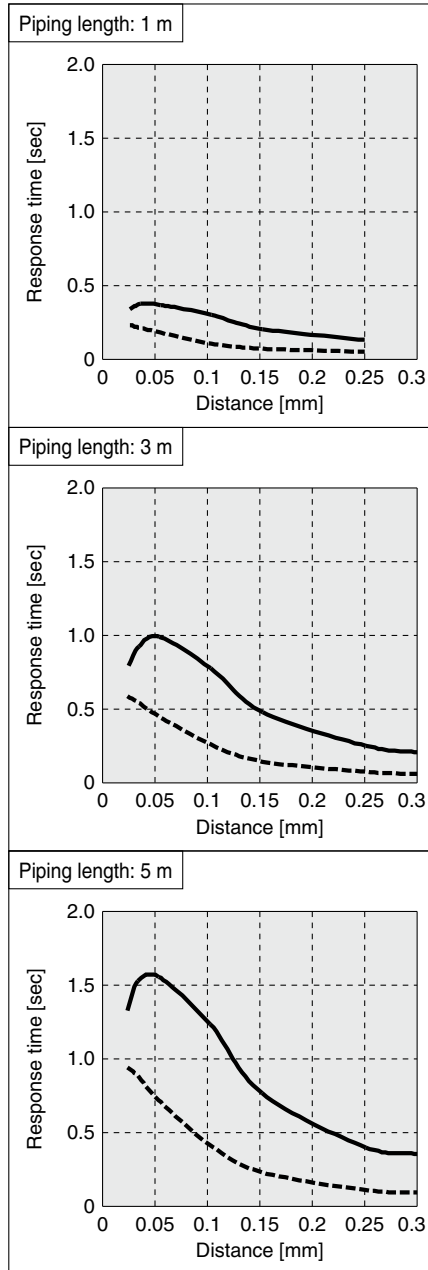

ISA3-H

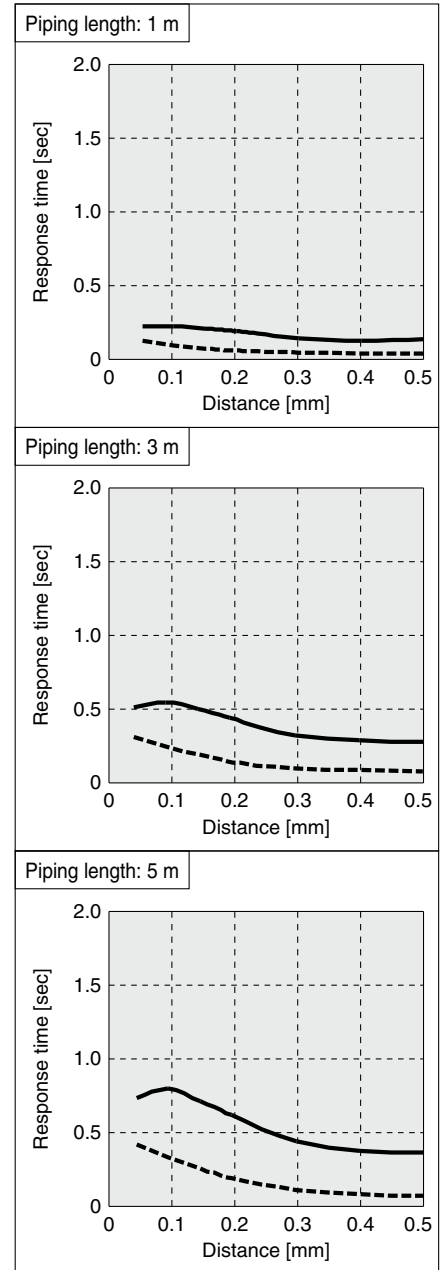

Relationship between Displayed Value and Distance

The graphs below show the relationship between the displayed value and distance. *: The data shown below are for reference. They change depending on the individual product differences, machining dimensions of the nozzle, etc.

Test conditions	Detection nozzle: $\phi 1.5$ Detection nozzle piping: F type $\phi 4 \times \phi 2.5$ tube 1 m, 3 m, 5 m/G, H type $\phi 6 \times \phi 4$ tube 1 m, 3 m, 5 m Supply pressure: 200 kPa
------------------------	---

ISA3-F

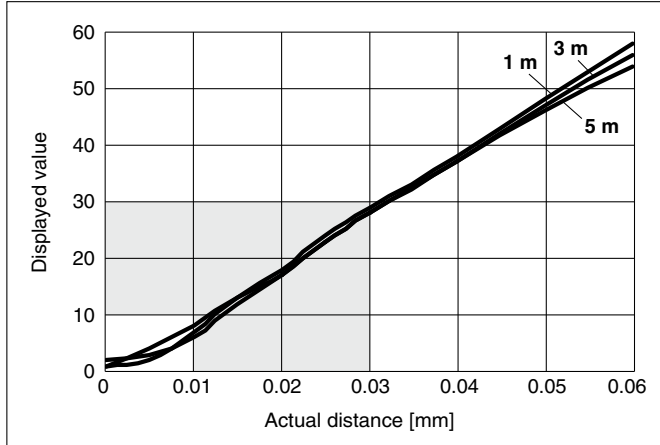

ISA3-G

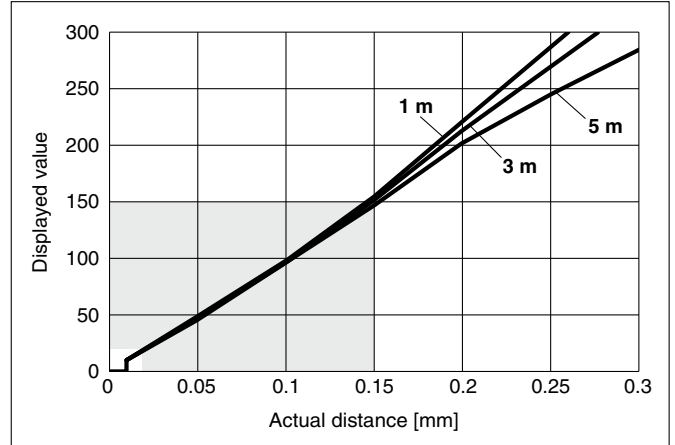

ISA3-H

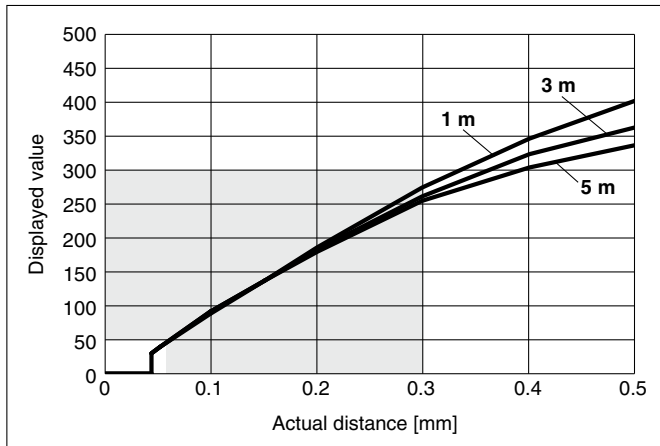

Nozzle Shape

The nozzle shape must be similar to Fig. 1. Do not chamfer the nozzle as shown in Fig. 2, as the characteristics will be affected.

Fig. 1: Recommended nozzle shape

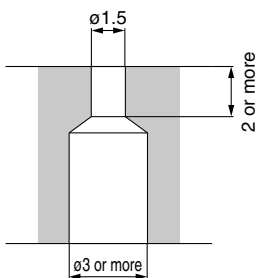
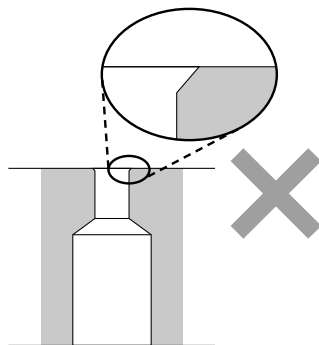
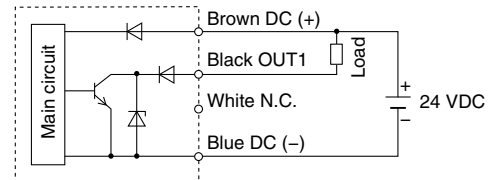

Fig. 2: Unsuitable nozzle shape



Internal Circuit and Wiring Example

ISA3-□□N NPN (1 output)



ISA3-□□P PNP (1 output)

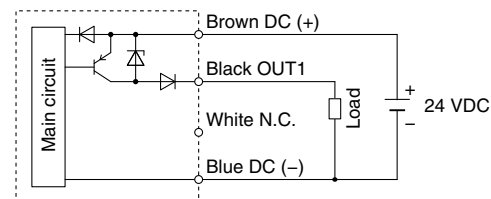

*: Refer to the **WEB catalog** for wiring details of the VX2 series (2 port solenoid valve).

ISA3 Series

Construction Diagram

Without control unit

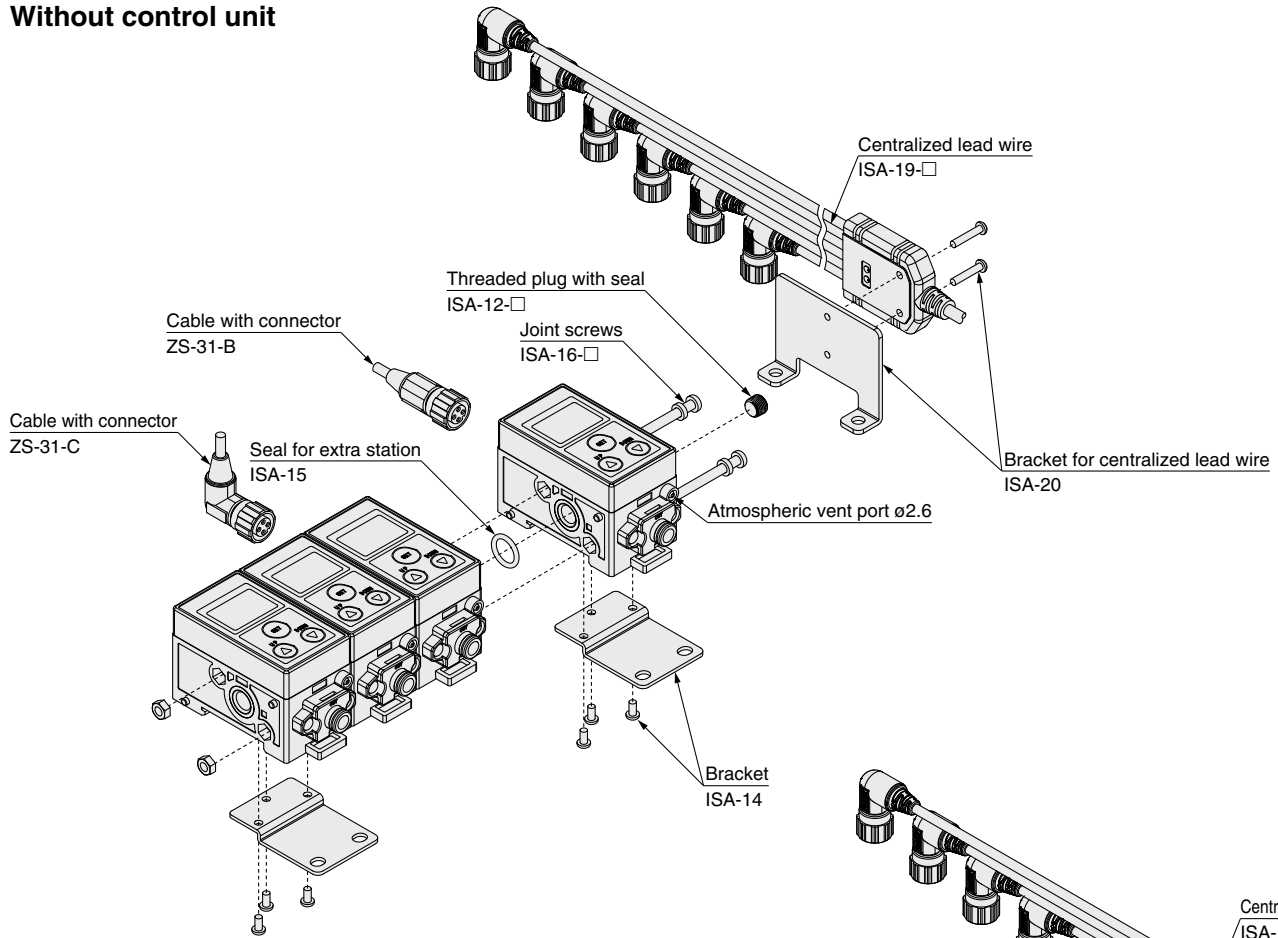

With control unit Supply port: Left side

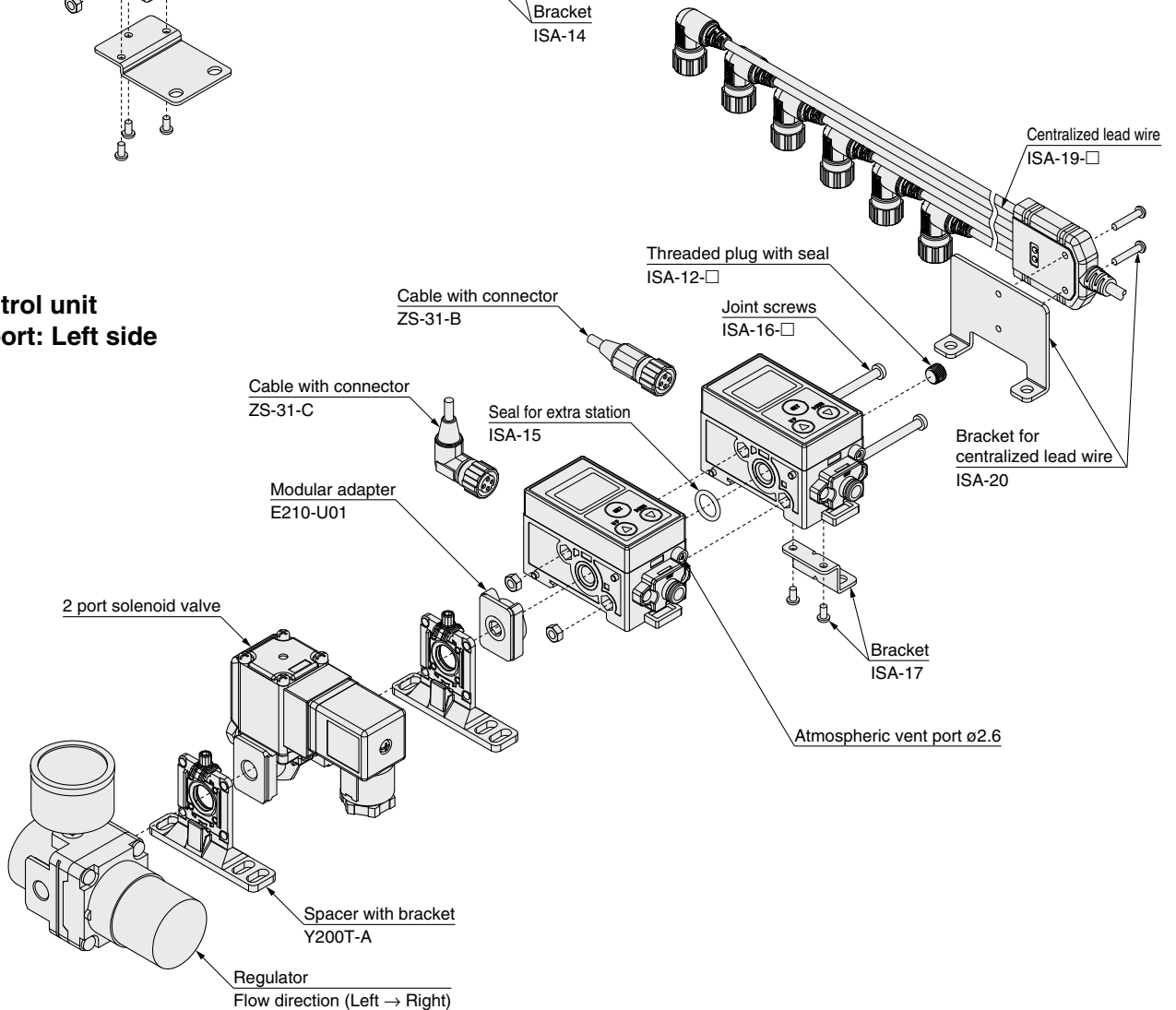

Construction Diagram

With control unit
Supply port: Right side

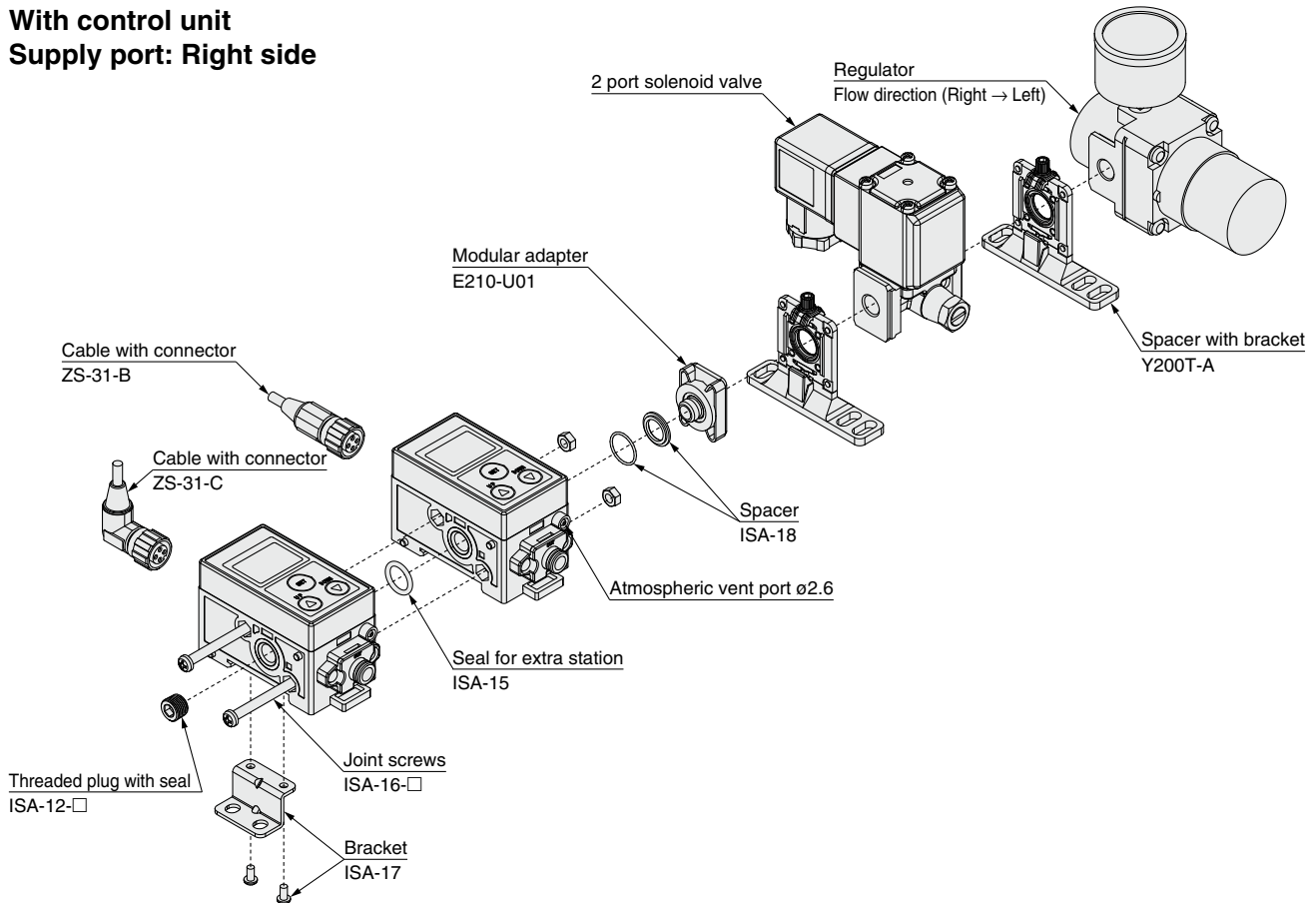

When the gap checker is used in a place where water and dust splashes may occur, insert a tube into the atmospheric vent port, and route the other end of the tube to a safe place away from water and dust.

*: SMC TU0425 (polyurethane, O.D. $\varnothing 4$, I.D. $\varnothing 2.5$) tubing suits to the gap checker.

Caution

SMC products are not intended for use as instruments for legal metrology.

Measurement instruments that SMC manufactures or sells have not been qualified by type approval tests relevant to the metrology (measurement) laws of each country. Therefore, SMC products cannot be used for business or certification ordained by the metrology (measurement) laws of each country.

ISA3 Series

Parts List

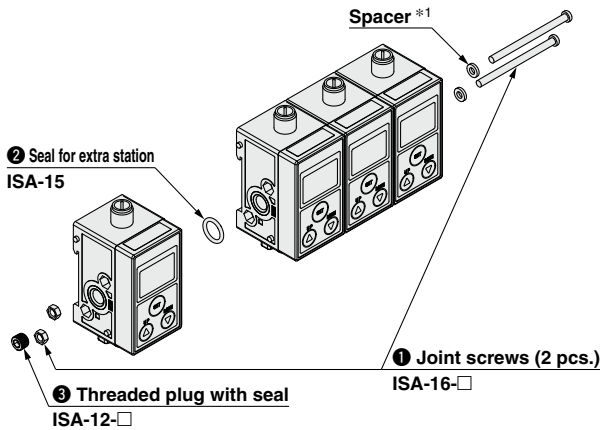

*1: Spacers are included for 4 and 6 stations.

- 1 Joint screws**
2 screws,
2 spacers, 2 nuts

Stations	Part no.
2	ISA-16-2
3	ISA-16-3
4 *1	ISA-16-4
5	ISA-16-5
6 *1	ISA-16-6

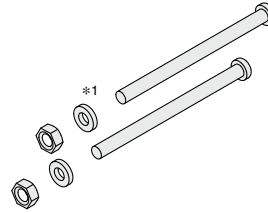

- 2 Seal for extra station**
ISA-15 1 pc.



- 3 Threaded plug with seal**
ISA-12-□ 1 pc.

Piping	Part no.
Rc1/8	ISA-12-A
G1/8	ISA-12-C



Bracket ISA-14

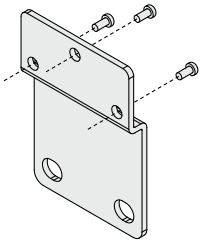

With 3 tapping screws (3 x 8)

DIN rail ISA-5-□

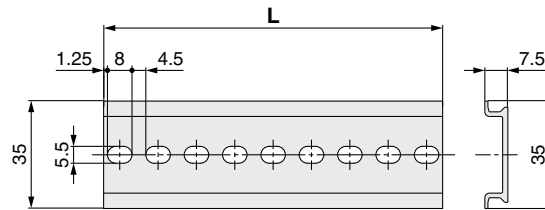

Stations	Part no.	L
1	ISA-5-1	73.0
2	ISA-5-2	135.5
3	ISA-5-3	173.0
4	ISA-5-4	210.5
5	ISA-5-5	248.0
6	ISA-5-6	285.5

Lead wire with connector ZS-31-B ZS-31-C

Straight 5 m

Right angle 5 m

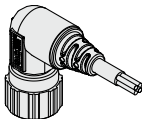

Centralized lead wire ISA-19-□

Stations	Part no.
2	ISA-19-2
3	ISA-19-3
4	ISA-19-4
5	ISA-19-5
6	ISA-19-6

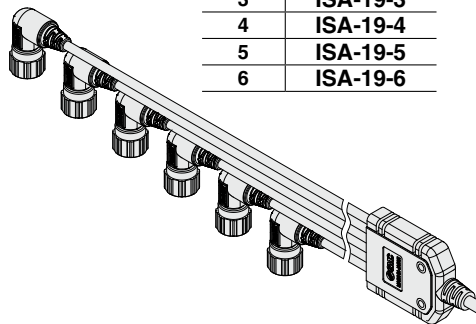

Bracket for centralized lead wire ISA-20

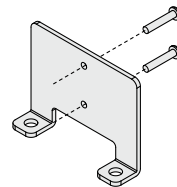

Parts List (Control Unit)

■ Regulator (Round type pressure gauge)

AR20 - □ 02G - 1 □ - A

● Piping specifications

Nil	Rc1/4
F	G1/4 *1

*1: Conforming to ISO16030

● Flow direction

Nil	Flow direction (Left → Right)
R	Flow direction (Right → Left)

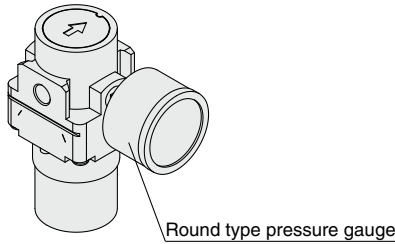

Refer to the **WEB catalog** for details.

■ Regulator (Square embedded type pressure gauge)

AR20 - □ 02E - 1 □ - B

● Piping specifications

Nil	Rc1/4
F	G1/4 *1

*1: Conforming to ISO16030

● Flow direction

Nil	Flow direction (Left → Right)
R	Flow direction (Right → Left)

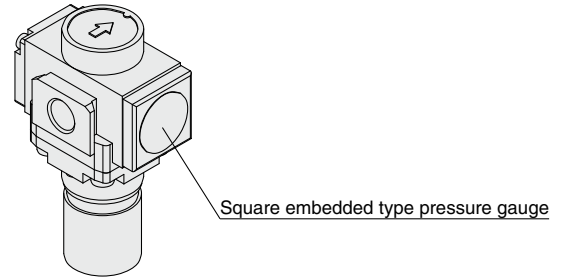

Refer to the **WEB catalog** for details.

■ 2 port solenoid valve

VX210 □ □ X276

● Body material/Port size/Orifice diameter

Symbol	Body material	Port size	Orifice diameter
Z	Al	No thread machining (1/8)	ø4
B *1		Rc1/4	
D *1		G1/4	

*1: Made to Order

● Specifications

Symbol	Specifications
X276	With restrictor

● Voltage/Electrical entry

Symbol	Voltage	Electrical entry
Z2A	24 VDC	DIN terminal with light (With surge voltage suppressor)
Z2B *2	100 VAC	
Z2C *2	110 VAC	

*2: Made to Order. When 100 VAC and 110 VAC are selected, the product without thread machining (symbol: Z) cannot be selected.

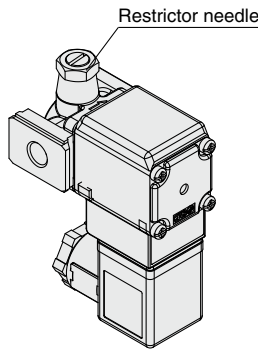

For specifications other than X276, refer to the **WEB catalog**.

■ Bracket (when control unit fitted) ISA-17

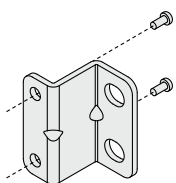

With 2 tapping screws (3 x 8)

■ Spacer with bracket Y200T-A

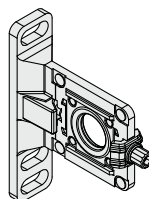

■ Modular adapter E210-U01

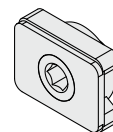

■ Spacer ISA-18



*: When a 2 port solenoid valve is connected to the right.

ISA3 Series

Dimensions

ISA3-□□ (Bracket mounting)

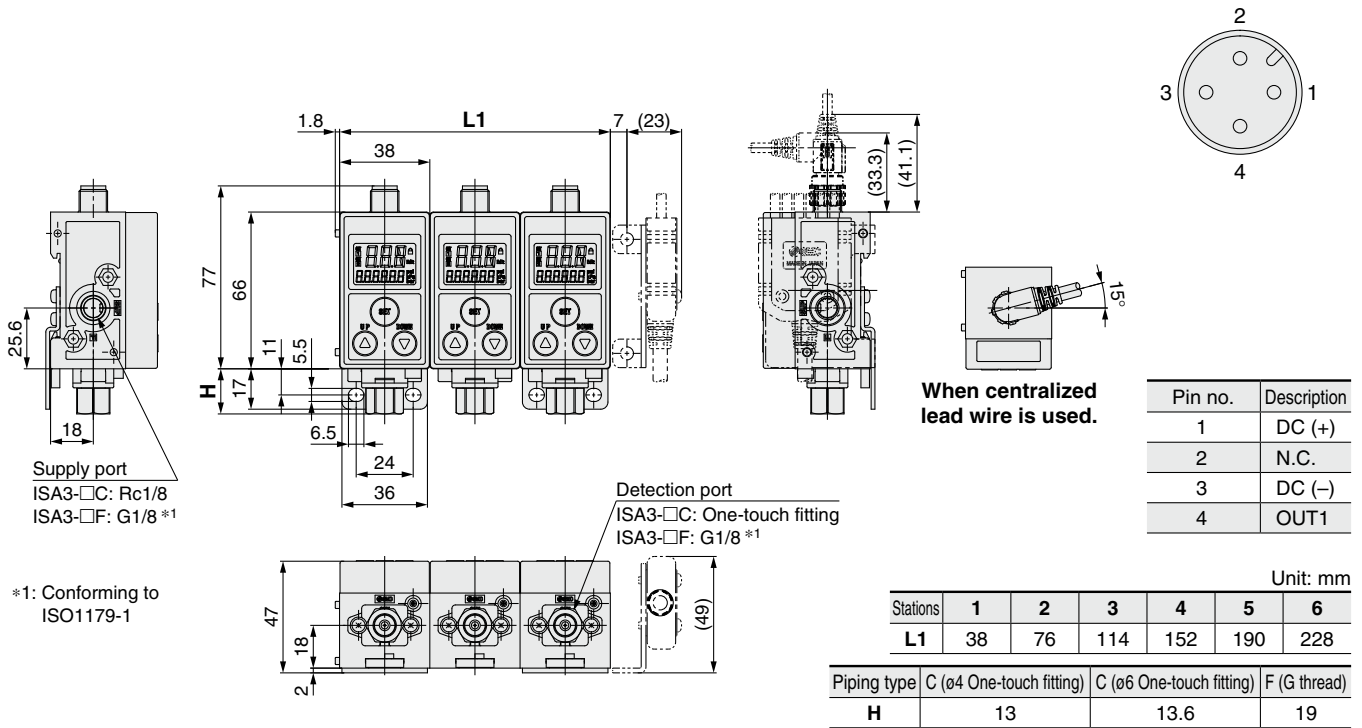

ISA3-□□ (DIN rail mounting)

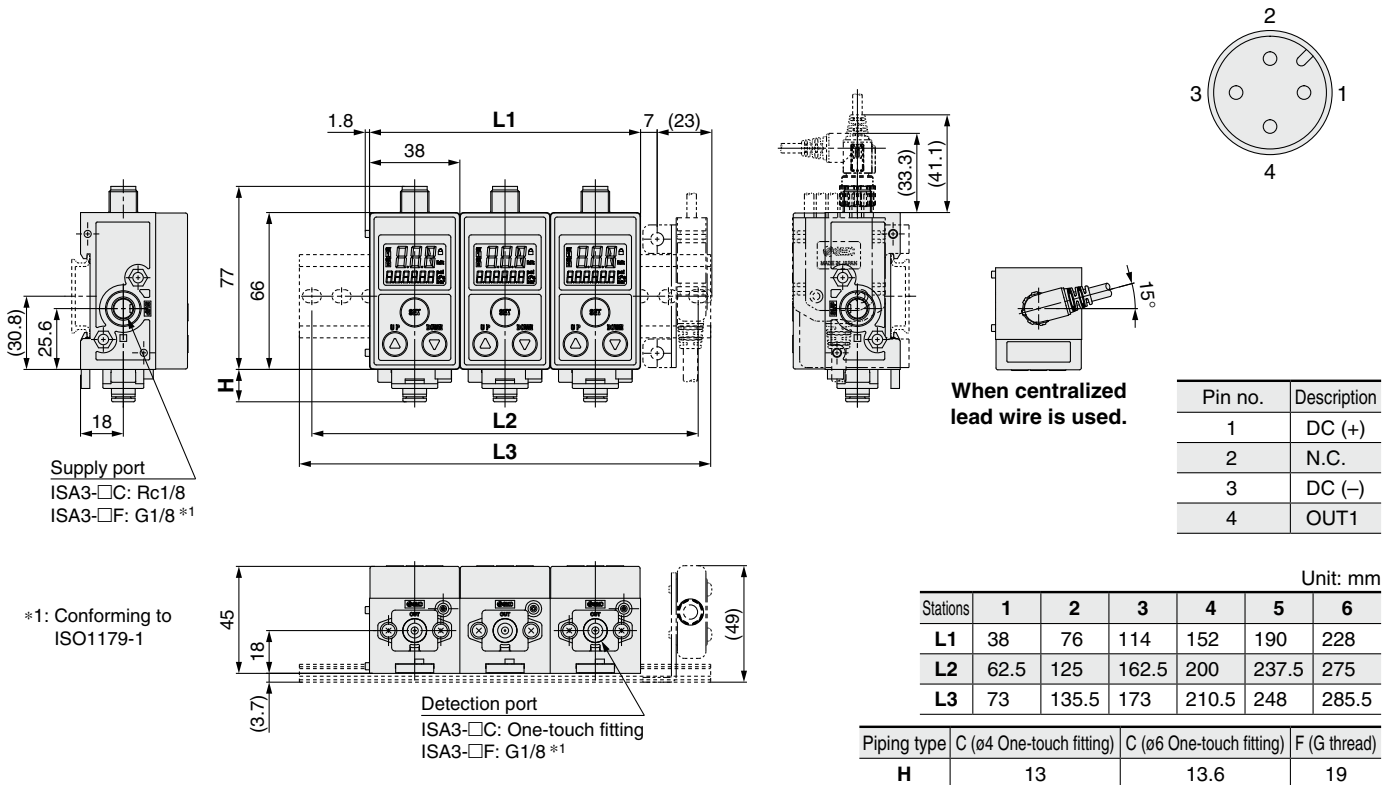

Dimensions

ISA3-□□□-□□□B-L1 (With control unit)

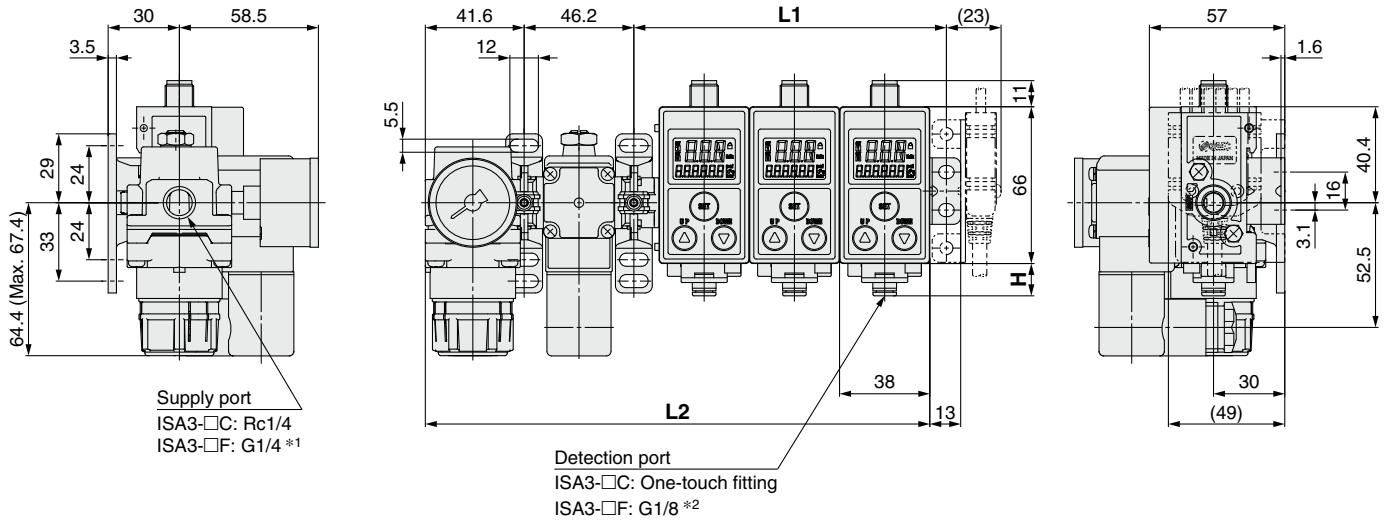

ISA3-□□□-□□□B-R1□

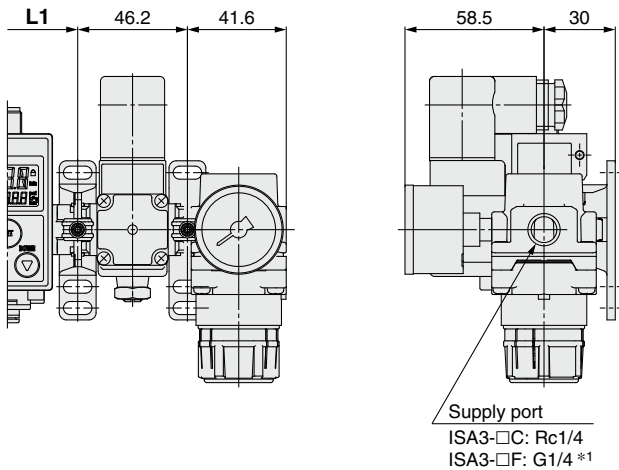

ISA3-□□□-□□□B-R2□

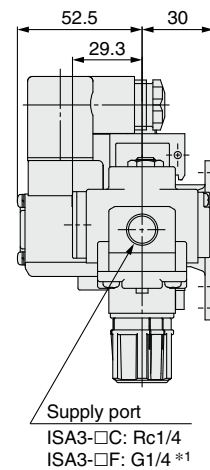

ISA3-□□□-□□□B-LN□

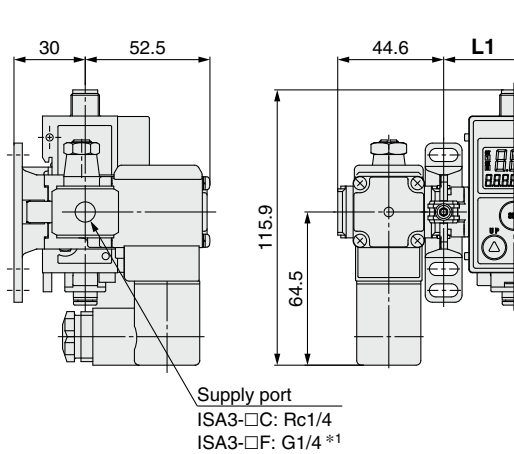

ISA3-□□□-□□□B-RN□

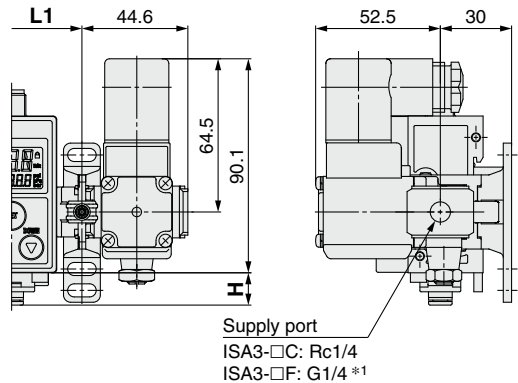

- *: Bracket mounting only
- *1: Conforming to ISO16030
- *2: Conforming to ISO1179-1

Unit: mm

Stations	1	2	3	4	5	6
L1	55.6	93.6	131.6	169.6	207.6	245.6
L2	136.4	174.4	212.4	250.4	288.4	326.4
Piping type	C (ø4 One-touch fitting)		C (ø6 One-touch fitting)		F (G thread)	
H	13		13.6		19	

ISA3 Series

Dimensions

ZS-31-B (Cable with connector)

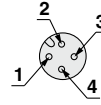
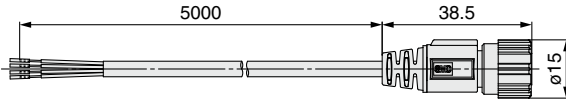

Connector pin no.

ZS-31-C (Cable with connector)

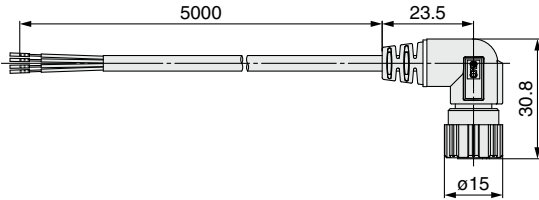

Pin no.	Lead wire color	Description
1	Brown	DC (+)
2	White	N.C.
3	Blue	DC (-)
4	Black	OUT1

ISA-19-□ (Centralized lead wire)

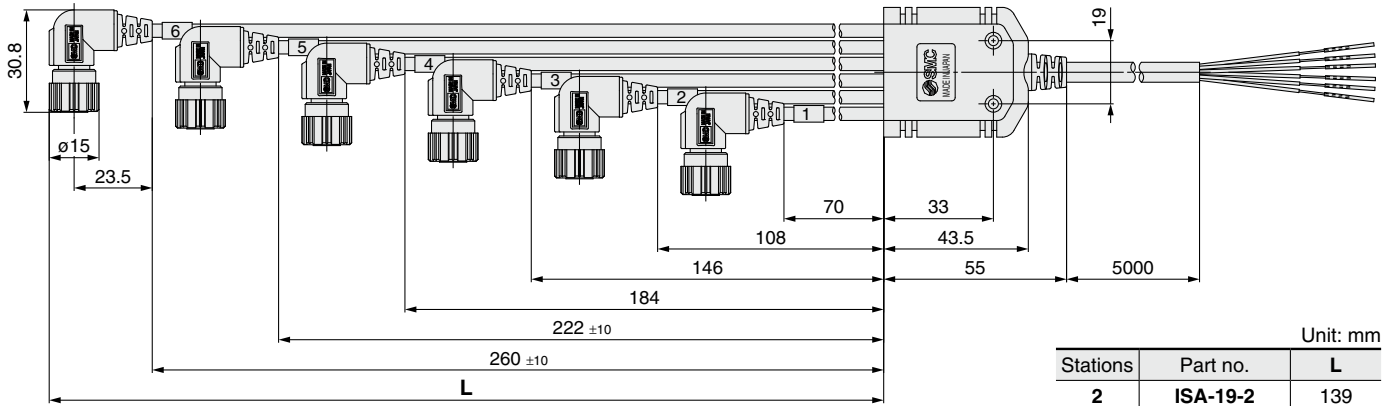

Unit: mm

Stations	Part no.	L
2	ISA-19-2	139
3	ISA-19-3	177
4	ISA-19-4	215
5	ISA-19-5	253
6	ISA-19-6	291

M12 connector no.	Pin no.	Description	Lead wire color	(Output wire color)
1	1	DC (+)	Brown *1	Black
	2	N.C.	—	
	3	DC (-)	Blue *1	
	4	OUT1		
2	1	DC (+)	Brown *1	White
	2	N.C.	—	
	3	DC (-)	Blue *1	
	4	OUT1		
3	1	DC (+)	Brown *1	Gray
	2	N.C.	—	
	3	DC (-)	Blue *1	
	4	OUT1		
4	1	DC (+)	Brown *1	Orange
	2	N.C.	—	
	3	DC (-)	Blue *1	
	4	OUT1		
5	1	DC (+)	Brown *1	Red
	2	N.C.	—	
	3	DC (-)	Blue *1	
	4	OUT1		
6	1	DC (+)	Brown *1	Green
	2	N.C.	—	
	3	DC (-)	Blue *1	
	4	OUT1		

*1: Brown and blue are connected inside the product.

Dimensions

ISA-14 (Bracket when control unit not fitted)

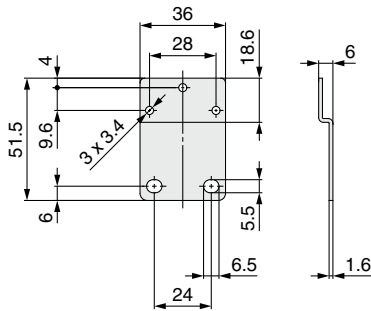

Y200T-A (Spacer with bracket)

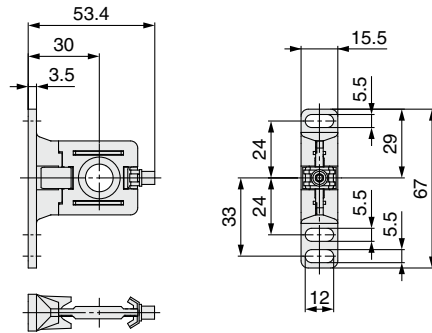

ISA-17 (Bracket when control unit fitted)

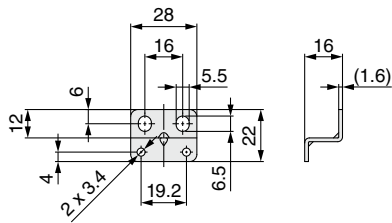

ISA-20 (Bracket for centralized lead wire)

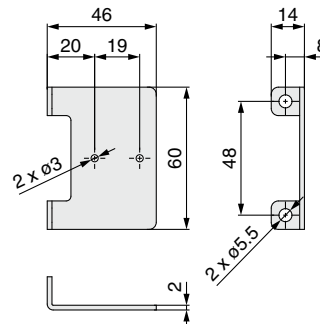

Error Indication

Main screen	Name	Description	Measures
- - -	Supply pressure error	Displayed when supply pressure is outside the range of 80 kPa to 220 kPa. Measurement is not possible.	Supply rated pressure (100 kPa to 200 kPa). The product will return to measurement mode automatically.
- - -	Outside of the displayable range (Switch point change mode)	The workpiece is outside the displayable range.	Move the workpiece closer to the detection nozzle.
Er 1	OUT1 over current error	The switch output (OUT1) load current has exceeded 80 mA.	Turn the power OFF and remove the cause of the over current. Then turn the power ON again.
Er 3	Zero clear error	Zero clear was not performed at atmospheric pressure. (Pressure outside of ± 14 kPa was supplied present.)	Perform zero clear at atmospheric pressure.
Er 0	System error	An internal data error has occurred.	Turn the power OFF and turn it ON again.
Er 4 to Er 9			
Sub screen	Name	Description	Measures
HHH	Supply pressure error (When [SUP side pressure value display] is set to the sub screen)	Pressure exceeding 220 kPa is supplied.	Keep the supply pressure within the displayable range of -20 kPa to 220 kPa.
LLL		Vacuum pressure (less than or equal to -20 kPa) is supplied.	

Relationship between Supply Pressure and Display

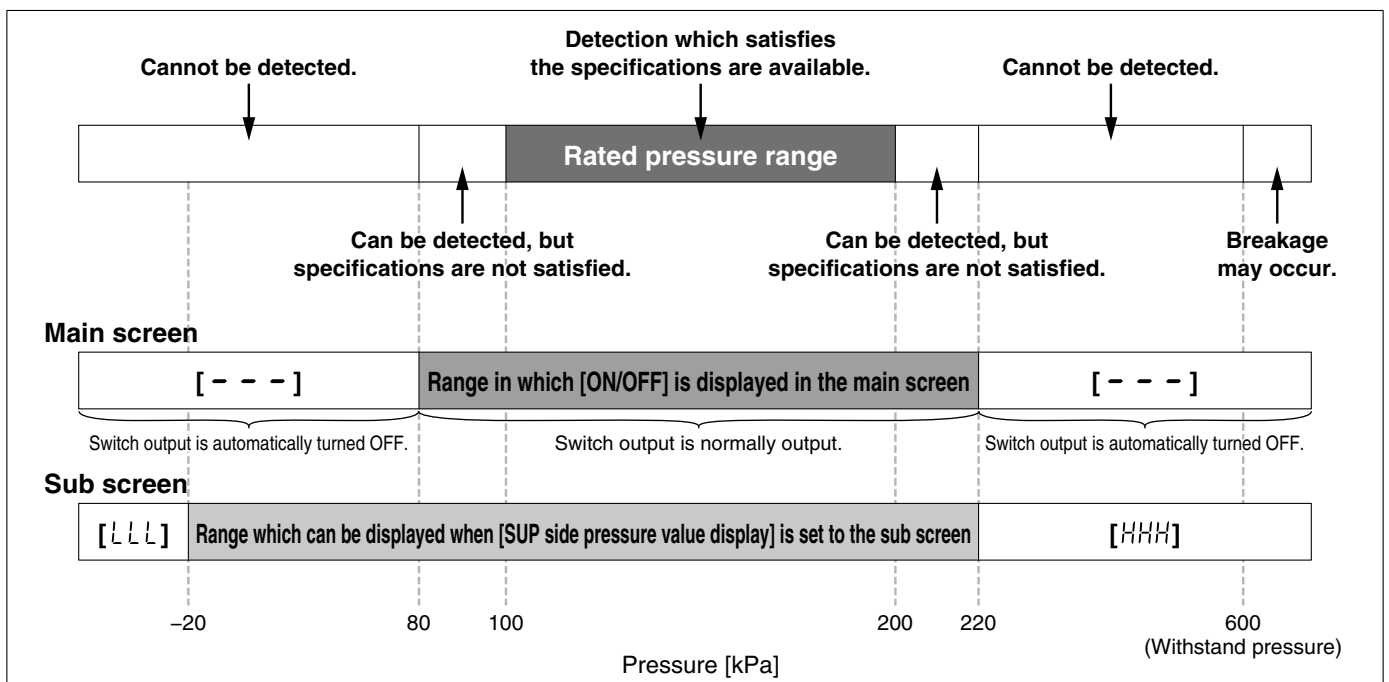

Safety Instructions

These safety instructions are intended to prevent hazardous situations and/or equipment damage. These instructions indicate the level of potential hazard with the labels of “**Caution**,” “**Warning**” or “**Danger**.” They are all important notes for safety and must be followed in addition to International Standards (ISO/IEC)*1), and other safety regulations.

 **Caution:** **Caution** indicates a hazard with a low level of risk which, if not avoided, could result in minor or moderate injury.

 **Warning:** **Warning** indicates a hazard with a medium level of risk which, if not avoided, could result in death or serious injury.

 **Danger :** **Danger** indicates a hazard with a high level of risk which, if not avoided, will result in death or serious injury.

*1) ISO 4414: Pneumatic fluid power – General rules relating to systems.
ISO 4413: Hydraulic fluid power – General rules relating to systems.
IEC 60204-1: Safety of machinery – Electrical equipment of machines.
(Part 1: General requirements)
ISO 10218-1: Manipulating industrial robots – Safety.
etc.

Warning

1. The compatibility of the product is the responsibility of the person who designs the equipment or decides its specifications.

Since the product specified here is used under various operating conditions, its compatibility with specific equipment must be decided by the person who designs the equipment or decides its specifications based on necessary analysis and test results. The expected performance and safety assurance of the equipment will be the responsibility of the person who has determined its compatibility with the product. This person should also continuously review all specifications of the product referring to its latest catalog information, with a view to giving due consideration to any possibility of equipment failure when configuring the equipment.

2. Only personnel with appropriate training should operate machinery and equipment.

The product specified here may become unsafe if handled incorrectly. The assembly, operation and maintenance of machines or equipment including our products must be performed by an operator who is appropriately trained and experienced.

3. Do not service or attempt to remove product and machinery/equipment until safety is confirmed.

1. The inspection and maintenance of machinery/equipment should only be performed after measures to prevent falling or runaway of the driven objects have been confirmed.
2. When the product is to be removed, confirm that the safety measures as mentioned above are implemented and the power from any appropriate source is cut, and read and understand the specific product precautions of all relevant products carefully.
3. Before machinery/equipment is restarted, take measures to prevent unexpected operation and malfunction.

4. Contact SMC beforehand and take special consideration of safety measures if the product is to be used in any of the following conditions.

1. Conditions and environments outside of the given specifications, or use outdoors or in a place exposed to direct sunlight.
2. Installation on equipment in conjunction with atomic energy, railways, air navigation, space, shipping, vehicles, military, medical treatment, combustion and recreation, or equipment in contact with food and beverages, emergency stop circuits, clutch and brake circuits in press applications, safety equipment or other applications unsuitable for the standard specifications described in the product catalog.
3. An application which could have negative effects on people, property, or animals requiring special safety analysis.
4. Use in an interlock circuit, which requires the provision of double interlock for possible failure by using a mechanical protective function, and periodical checks to confirm proper operation.

Caution

1. The product is provided for use in manufacturing industries.

The product herein described is basically provided for peaceful use in manufacturing industries.
If considering using the product in other industries, consult SMC beforehand and exchange specifications or a contract if necessary.
If anything is unclear, contact your nearest sales branch.

Limited warranty and Disclaimer/ Compliance Requirements

The product used is subject to the following “Limited warranty and Disclaimer” and “Compliance Requirements”.

Read and accept them before using the product.

Limited warranty and Disclaimer

1. The warranty period of the product is 1 year in service or 1.5 years after the product is delivered, whichever is first.*2)
Also, the product may have specified durability, running distance or replacement parts. Please consult your nearest sales branch.
2. For any failure or damage reported within the warranty period which is clearly our responsibility, a replacement product or necessary parts will be provided.
This limited warranty applies only to our product independently, and not to any other damage incurred due to the failure of the product.
3. Prior to using SMC products, please read and understand the warranty terms and disclaimers noted in the specified catalog for the particular products.

*2) Vacuum pads are excluded from this 1 year warranty.

A vacuum pad is a consumable part, so it is warranted for a year after it is delivered.
Also, even within the warranty period, the wear of a product due to the use of the vacuum pad or failure due to the deterioration of rubber material are not covered by the limited warranty.

Compliance Requirements

1. The use of SMC products with production equipment for the manufacture of weapons of mass destruction (WMD) or any other weapon is strictly prohibited.
2. The exports of SMC products or technology from one country to another are governed by the relevant security laws and regulations of the countries involved in the transaction. Prior to the shipment of a SMC product to another country, assure that all local rules governing that export are known and followed.

Caution

SMC products are not intended for use as instruments for legal metrology.

Measurement instruments that SMC manufactures or sells have not been qualified by type approval tests relevant to the metrology (measurement) laws of each country. Therefore, SMC products cannot be used for business or certification ordained by the metrology (measurement) laws of each country.

Revision history

Edition B * Added F type (Rated distance range: 0.01 to 0.03 mm).

ST

Edition C * Added centralized lead wire.
* Added the AR-B series regulator (control unit).
* Added AC type 2 port solenoid valve (control unit).
* Number of pages increased from 16 to 24.

US

Safety Instructions

Be sure to read the “Handling Precautions for SMC Products” (M-E03-3) and “Operation Manual” before use.