

INFORMATION **New!**

Positioning Driver Series LC6C

Driver LC6D has built-in pulse control function

Position information can be set up to a maximum of 28 points

Point movement can be easily accomplished with a PLC, etc.

Compatible with Series LX electric actuator 2-phase stepping motor



Application examples

Can be used in operation patterns like these.

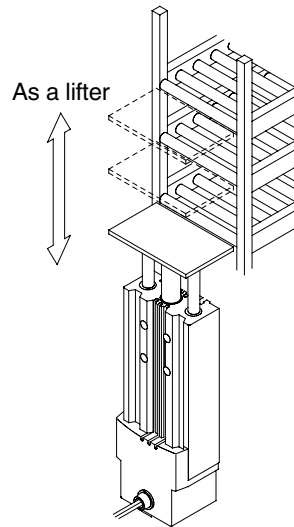
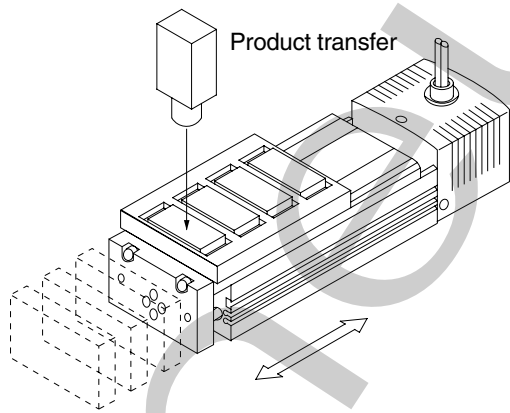

System configuration

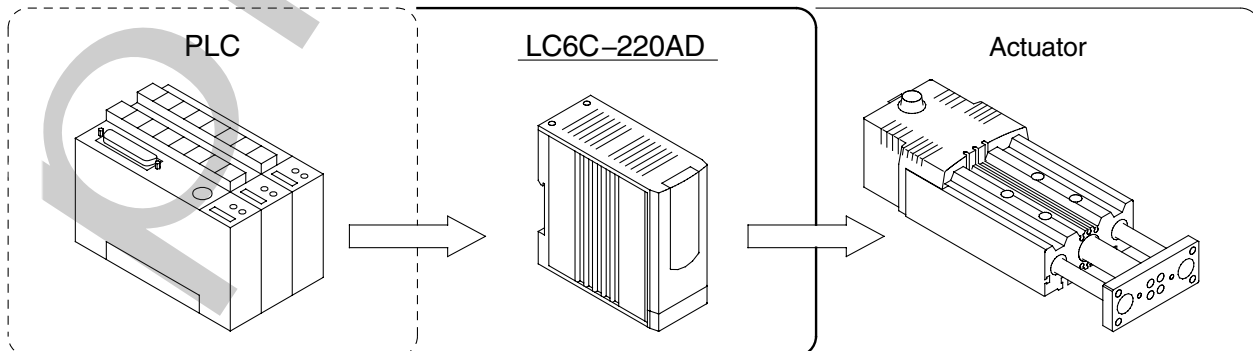

To be provided by customer.

How to Order

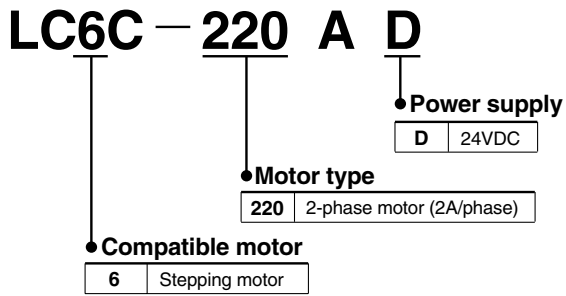

Specifications

Compatible actuator	LX□□2□□-□□□□□
Power supply	24VDC ± 10% Max. 3.0A
Number of setting positions	28 points
Position setting method	Setting with dedicated teaching box (LC5-1-T1-02)
Position control method	Absolute and incremental moves Speed: 6 to 200mm/s (0.2 to 8in/s) [with feed screw lead of 12mm (0.5in)]
Input signal capacity	Optically isolated input 24VDC Max. 6mA
Output signal capacity	Optically isolated output Max. 30VDC or less Max. 20mA
Parameter setting	Position data setting, Speed acceleration setting, etc.
Indication LED	LED for power supply, LED for alarm
Operating temperature	5 to 40°C (41° to 104°F)

Dimensions (mm)

1in=25.4mm

LC6C-220AD

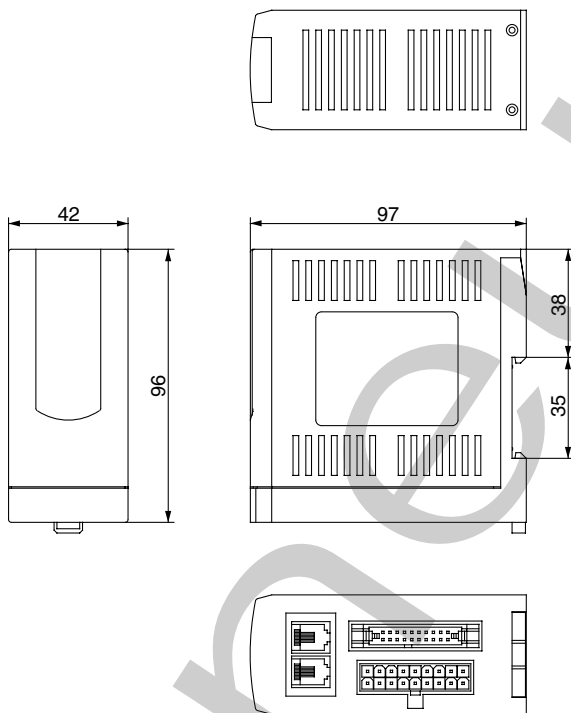

Dedicated teaching box LC5-1-T1-02

