



Contact our sales office regarding a delivery date or a price since this is a special model.

SMC P.G.Information (Specialized Product)

SP158X-002E
P: TS

Liquid Dispense Pump (Solenoid type) Series LSP

SMC Corporation
4-14-1, SOTO-KANDA,
CHIYODA-KU,
TOKYO 101-0021, JAPAN
URL: <http://www.smcworld.com>

■ Features

Compact solenoid type diaphragm pump, which dispenses fixed amount of liquid from 5 μ L to 200 μ L each time it is operated.

Adjustment of dispense volume is possible.

Dispense volume can be changed by adjusting the armature stroke with adjustment screw.

Dispense volume:

5 to 50 μ L/Shot
50 to 100 μ L/Shot
100 to 200 μ L/Shot

Dispense volume stability

(Repeatability $\pm 1\%$)* Note1)

Diaphragm movement is supported by buffer. Stable dispense volume and longer life can be achieved by restricting deformation of the diaphragm.

* $\pm 2\%$ when the dispense volume is 5 to 15 μ L. Note1)

Note1) Under SMC's measuring conditions

Shut-off function

Liquid leakage to the OUT side due to a siphonic phenomenon can be prevented by seating with diaphragm.

No need to install an external shut-off valve designed to prevent leakage before and after the pump. Note2)

Note2) This depends on the dispense volume adjustment, fluid and piping conditions.

Self-priming makes priming unnecessary.

Sucks the liquid even if the pump is dry.

Fluid contact material

Body

Can be selected from

PEEK or PP

Diaphragm
Check valve

Can be selected from

EPDM or FKM

Fluid Note3)

Water, DI water, Diluent, Cleaning liquid

Note3) These fluids should not corrode or permeate into the fluid contact materials.

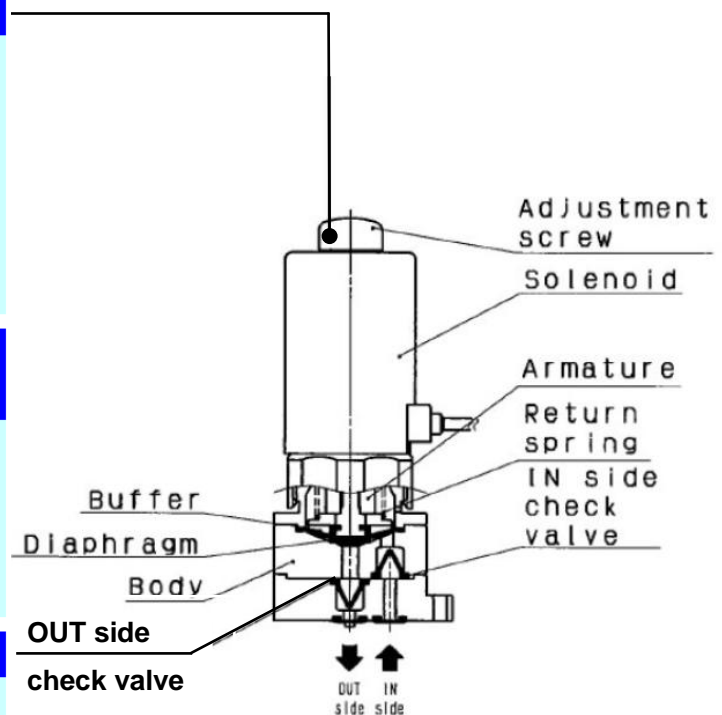

Application Example

【Analyzer】
(for medical/biochemical)

【Ink jet printing】

【Related to semiconductor/solar cell】



How to Order



Body ported



Base mounted

Body ported	LSP1	1	1-5	A	□
Base mounted	LSP1	1	2-5	A	□

Dispense volume

1	5 to 50 μ L
2	50 to 100 μ L
3	100 to 200 μ L

Coil voltage

5	24 VDC
6	12 VDC

Port size

Symbol	Port size
1	M5
2	M6
3	1/4-28UNF

Fluid contact material

Symbol	Body	Diaphragm	Check valve
A	PEEK	EPDM	EPDM
B	PEEK	FKM	FKM
C	PP	EPDM	EPDM
D	PP	FKM	FKM

■ Specifications

Model	LSP111/112	LSP121/122	LSP131/132
Dispense volume adjustable range ^{Note1)}	5~50μL	50~100μL	100~200μL
Fluid ^{Note4)}	Water, DI water, Diluent, Cleaning liquid (Note: These fluids should not corrode or permeate into the fluid contact materials.)		
Fluid contact material	Body	PEEK, PP	
	Diaphragm	EPDM, FKM	
	Check valve	EPDM, FKM	
Repeatability ^{Note1)}	±1%(±2% when the dispense volume is 5 to 15μL) *Under SMC's measuring conditions		
Dispense pressure ^{Note2)}	10kPa		
Suction pressure	Dry	15kPa	
	Wet	35kPa	
Max.operating frequency ^{Note3)}	2Hz(Minimum ON time 200msec/Minimum OFF time 300msec)		
Fluid temperature	10 to 50°C(No freezing)		
Ambient temperature	10 to 50°C(No freezing)		
Mounting orientation	Unrestricted ^{Note5)}		
Enclosure	Equivalent to IP40		
Weight	90g(Body ported), 85g(Base mounted)		
Rated voltage	12VDC, 24VDC		
Allowable voltage fluctuation	±10% of the rated voltage ^{Note6)}		
Type of coil insulation	Class B		
Lead wire	AWG20(Outside diameter of insulator: 1.79mm)		
Power consumption	4W	9W	17W
Operation noise	60dB(A) or less ^{Note7)}		

Note1) The values above are at ambient temperature, with clean water at zero pressure. The dispense volume and repeatability of vary, depending on the piping conditions (height, diameter, length etc.), of the INLET and OUTLET sides, and the ambient and fluid temperatures. For stable dispensing, use the product in a balanced condition where pressure is not applied to the INLET and OUTLET side as much as possible. Do not apply excessive torque when rotating the discharge volume adjustment screw. If the screw is tightened too much, it may lead to product failure or cause the screw to shear.

When calculating the repeatability, measure the amount of clean water which is dispensed 10 times continuously and convert it to one shot of dispensed volume. Repeat this measurement 10 times, and indicate the difference (%) between the average value of 10 sets of data (converted value of one shot) and the maximum and minimum values. These values are calculated based on SMC measurement conditions, so the repeatability accuracy is not guaranteed.

<Variation in SMC measurement conditions>

Ambient/fluid temperature: ±2 degrees, IN/OUT side piping pressure: ±0.1kPa or less

Note2) The value is measured when the maximum dispense volume of clean water at room temperature is adjusted. This value will vary depending on the dispense volume and fluid conditions.

Note3) High speed operation affects the dispense volume and accuracy.

The maximum operation frequency is decreased by the fluid characteristics(large viscosity) and the piping condition(large pipingresistance). When the pump is used continuously for extended periods of time, make the OFF time appropriately longer with the minimum ON time of 200 msec to set the operating frequency to 1 Hz or less. When using this product with the maximum operating frequency or less, the coil temperature may rise due to ambient temperature and energizing time, so makethe OFF time appropriately longer.

Note4) Select an appropriate fluid contact material when fluid such as cleaning liquid is used. Also, check the fluid compatibility in advance. Some fluids may have an influence on the dispense volume and repeatability. After mounting is complete, perform appropriate functional inspections.

Note5) Mount the coil in a downward, vertical direction to facilitate the release of air bubbles for a stable dispensing. In order to achieve a stable dispensing, operate the pump continuously for a short time to remove air from the piping and product completely. We recommend using deaerated fluid.

Note6) When the responsiveness is regarded as important, prevent negative fluctuation of the voltage by adequate regulation.

Note7) The value is based on SMC's measurement conditions. The noise level will vary with conditions.

Construction

Body ported / LSP1□1

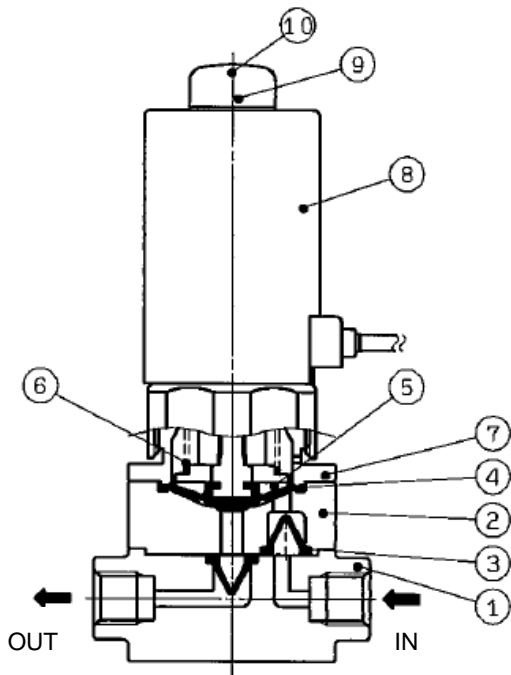

Base mounted / LSP1□2

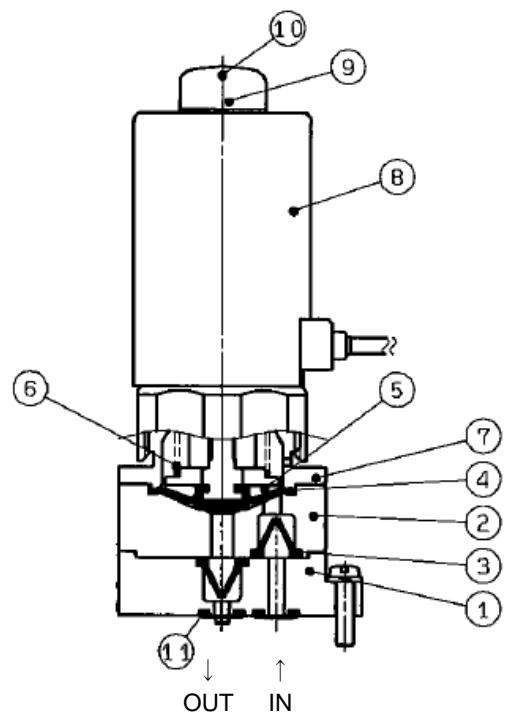

Working Principle

When the pump turns ON (is energized), the diaphragm will perform a stroke to the solenoid side. This condition makes the pressure in the pump negative and the check valve on the OUT side is closed. Fluid passed through the suction port then the check valve on the IN side and is sucked in the pump chamber. When the pump turns OFF (is de-energized), the diaphragm performs a stroke to the body side with return force of the return spring. Due to this, the check valve on the IN side is closed, and fluid in the pump chamber passed through the check valve on the OUT side and is dispensed from the OUT port. Suction and dispensing are repeated with repetitive ON/OFF operation.

Component Parts

No.	Description	Material
1	Plate	PEEK, PP
2	Body	PEEK, PP
3	Check valve	EPDM, FKM
4	Diaphragm	EPDM, FKM
5	Buffer	NBR
6	Return spring	SUS
7	Housing	PPS
8	Solenoid	—
9	Dispense volume adjustment screw	SUS
10	Cap	EPDM
11	O-ring	EPDM, FKM

Discharge volume adjustment

The dispense volume per shot can be changed by rotating the dispense volume adjustment screw.

When rotating the discharge volume adjustment screw clockwise, the discharge volume decreases. When rotating it counterclockwise, the discharge volume increases.

Step 1 Remove the cap and loosen the lock nut while holding the dispense volume adjustment screw with a flat head screw driver to prevent it from rotating. (Counterclockwise)

Step 2 Rotate the dispense volume adjustment screw to adjust the dispense volume.

Note) Do not apply excessive torque when rotating the dispense volume adjustment screw. If the screw is tightened too much, it may lead to product failure or cause the screw to shear.

Step 3 Tighten the lock nut while holding the dispense volume adjustment screw with a flat head screw driver to prevent it from rotating. (Clockwise)

* Lock nut tightening torque: 0.6 to 0.8 Nm

Note) Ensure that the lock nut is secured after adjusting the discharge volume.

If the Lock nut is not secured, the dispense volume may become unstable.

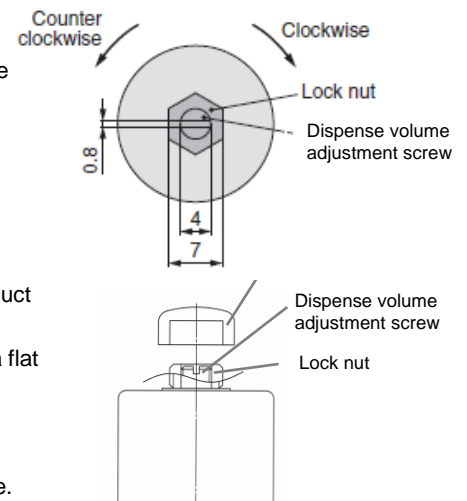

■ Dimensions

Body ported/LSP1□1

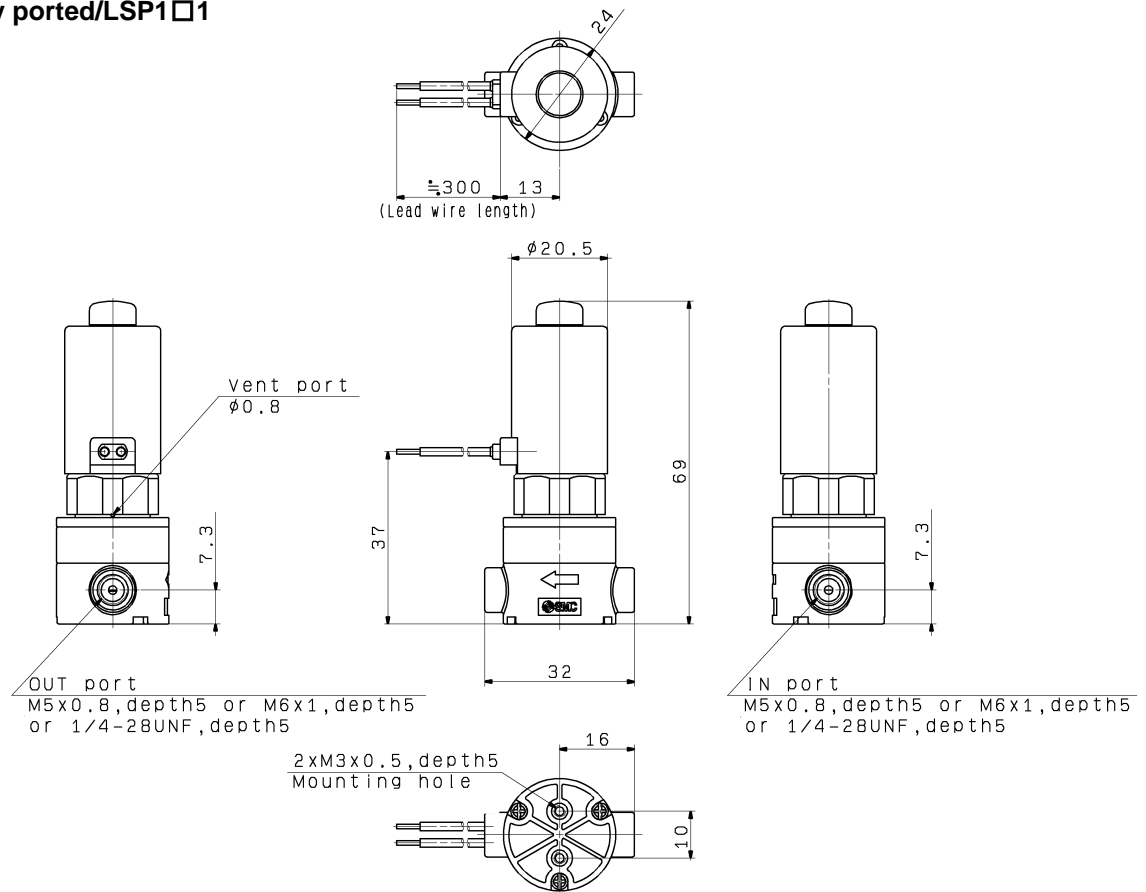

Base mounted/LSP1□2

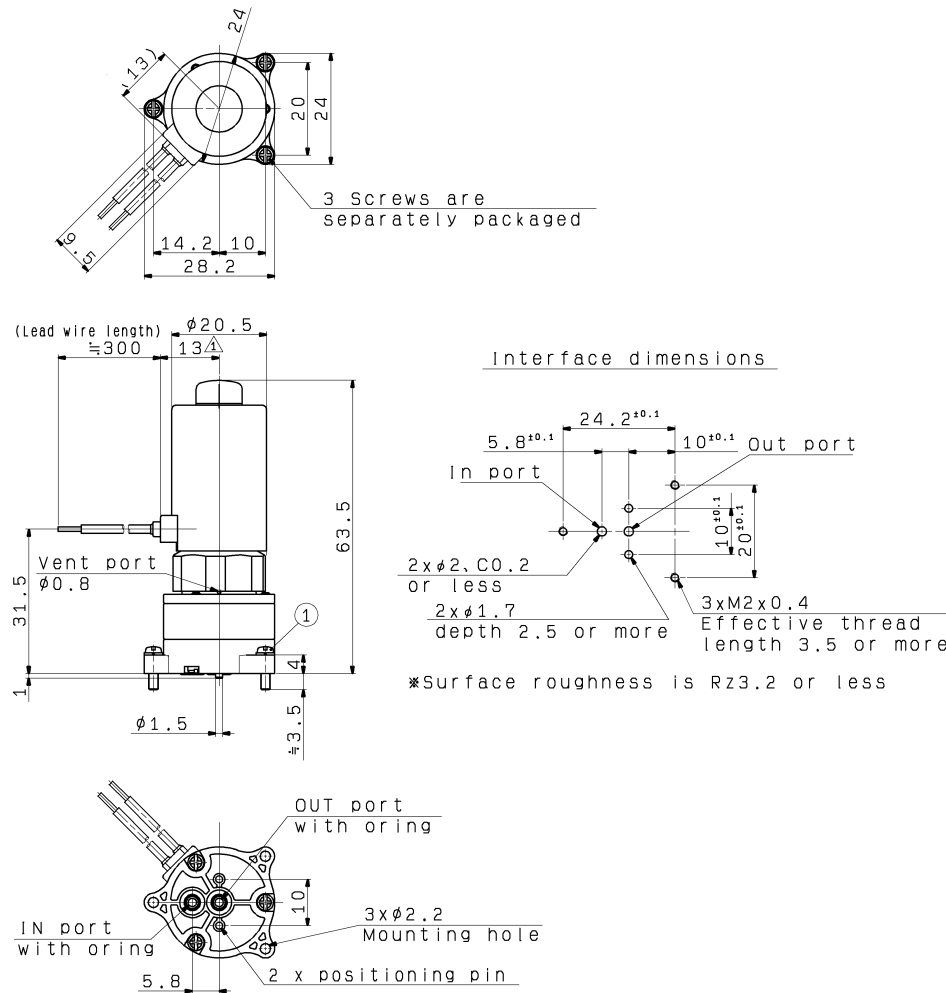

■ Specific Product Precautions1

Design/Selection

Warning

- 1. Do not use this product in applications which may adversely affect human life (e.g. medical equipment connected to the human body for drip infusion).**
- 2. Check the specifications.**

Give careful consideration to the operating conditions such as the application, fluid and environment, and use within the operating ranges specified in this manual.
- 3. For stable dispensing, please use the product under stable operating conditions (suction height, ambient temperature, fluid temperature). If air bubbles are present in the fluid and the piping material is soft, it may influence on the repeatability of the dispense volume. When the piping diameter of the fluid outlet is large, repeatability may be influence due to surface tension, so it is recommended to reduce the piping diameter with the installation of a nozzle.**
- 4. Repeatability**

Measure the amount of clean water which is dispensed 10 times continuously and convert it to one shot of dispensed volume. Repeat this measurement 10 times, and indicate the difference (%) between the average value of 10 sets of data (converted value of one shot) and the maximum and minimum values. These values are calculated based on SMC measurement conditions, so the repeatability accuracy is not guaranteed.

<Variation in SMC measurement conditions>
Ambient / fluid temperature : ± 2 degrees,
IN/OUT side piping pressure : ± 0.1 kPa or less
- 5. Fluid**

Confirm the compatibility between the component material and the fluid before using. Since the compatibility of the fluid used may vary depending on its type, additives, concentration, temperature, etc., give sufficient consideration when selecting the material.

If foreign matter is mixed in the fluid, these may cause abrasion of the inside of the pump resulting in a problem. Install an appropriate filter (strainer) before the pump. As a guide, the appropriate filtration is approximately $50\mu\text{m}$. When circulating coagulable fluids, handle them carefully so that they do not coagulate in the pump.
- 6. Discharge volume may vary depending on the fluid and piping conditions.**

After mounting is complete, perform appropriate functional inspections.
- 7. Maintenance space**

The installation should allow sufficient space for maintenance activities.
- 8. Ambient environment**

Use within the allowable ambient temperature range. Make sure that the liquid or corrosive gas does not touch the external surface of the product. Specifically, do not expose the solenoid to fluid. This may cause short circuit. When touching the wet solenoid, an electric shock may occur.

9. Countermeasures against static electricity

Take measures to prevent static electricity since some liquids can cause static electricity.

10. Energizing for extended periods of time

If the pump is continuously energized for long periods, temperature rise due to heat generation of the coil may result in reduced performance and shorter service life or adversely affect the peripheral device. Therefore, if the pump is energized for long periods, take measures to cool the pump by mounting a fan to keep the surface temperature at 50°C or less. When the pump is mounted into a control panel, take measures to cool the pump and keep the operating temperature within the specified range.

11. If the product has not been used for a long time, perform a trial run before use. If the product is to remain inactive for a long period of time, remove the fluid from the pump.

12. Do not touch the pump directly with hands. The coil can be hot depending on the ambient temperature or energizing time. Install a protective cover over the valve if it can be touched directly with hands.

Selection

Caution

Voltages caused by leakage current may lead to pump malfunction.

Leakage voltage: 2% or less of the rated voltage

Mounting

Warning

- 1. If equipment does not operate properly, stop operation.**

After mounting is completed, confirm that it has been done correctly by performing a suitable function test.
- 2. Mount the coil in a downward, vertical direction to facilitate the release of air bubbles for a stable dispensing.**

After releasing air bubbles, mounting orientation is not specified.
- 3. Do not use this product in a location where it will be subject to vibration or impact. The dispense volume may become unstable in the presence of vibration at the pump or piping.**
- 4. Do not apply external force to the coil section.**
- 5. Install and operate the product only after reading the Operation Manual carefully and understanding its contents.**

■ Specific Product Precautions2

Piping

Caution

1. Install the tank so that the fluid level of the tank is lower than the pump.
2. When the dispense volume is small and the piping diameter is large, fluid is not dispensed with 1 shot due to surface tension of fluid. Select piping with appropriate diameter for a stable dispensing.
3. It is recommended that hard tubing is used, as the use of soft tubing may lead to instability in the dispense volume due to tubing deformation.
4. Preparation before piping

Before piping is connected, it should be thoroughly blown out with air (flushing) or washed to remove chips, cutting oil and other debris from inside the pipe.

5. Always tighten threads with the proper tightening torque.

When screwing fittings into the pump, tighten them with proper tightening torque as shown below.

For base piping, tighten the screw completely to the proper torque after confirming that the O-ring is mounted on the interface properly.

Tightening Torque for Piping

Model	Thread size	Proper tightening torque N·m
Body ported	M5, M6, 1/4-28UNF	0.4 to 0.6
Base mounted	M2	0.15 to 0.2

* Reference

M5, M6, 1/4-28UNF thread type fitting: After tightening by hand, tighten approximately 1/6 turn with a tightening tool.

Wiring

Caution

1. Use electrical circuits which do not generate chattering in their contacts.
2. Use within $\pm 10\%$ of the rated voltage.
However, when the responsiveness is regarded as important, prevent negative fluctuation of the voltage by adequate regulation.
3. Apply the correct voltage.
Applying incorrect voltage may cause a malfunction or a burned coil.
4. Make sure that no excessive force is applied to the lead wires.
Otherwise, the coil will burn.

Fluid Properties

Warning

Liquid (chemicals)

When component crystallizes or clots depending on its nature, malfunction will occur due to the diaphragm or check valve sticking. When a crystallized or clotted component is caught between the sealing parts, unstable liquid dispensing will occur. Take measures to clean such component if necessary.

Water

Install a filter strainer of about 50 μ m on the inlet side of the piping.

Operating Environment

Warning

1. Do not use in explosive atmospheres.
2. Do not use in locations subject to excessive vibration or impact.
3. Do not use in locations where radiated heat will be received from nearby heat sources.

Maintenance

Warning

1. Removing the product

Shut off the fluid supply and release the fluid pressure in the system. Shut off the power supply. Remove the product.

2. Before operating, remove residual chemicals and completely replace it with deionized water, air, etc.
3. Do not disassemble the product.

Products which have been disassembled cannot be guaranteed.

If disassembly is necessary, please contact SMC.



Caution To ensure the safest possible operation of this product, please be sure to read thoroughly the "Safety Instructions" in our "Best Pneumatics" catalog before use.