

# High Purity Chemical Valve Non-Metallic Exterior

## Series LVQ

*Clean Wet Series*

### Constructed without screws

Non-metallic construction without using metal screws to fasten the body of the actuator.

Body: New PFA  
 Diaphragm: PTFE  
 Actuator section: PVDF

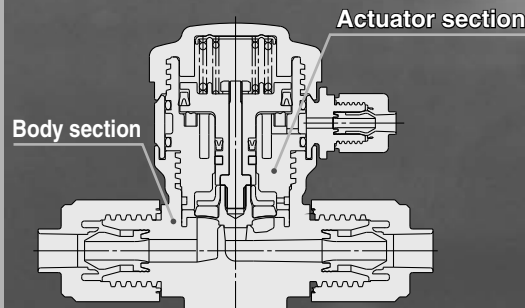

- LVC
- LVA
- L VH
- LVD
- LVQ**
- LQ1
- LVN
- TL/TIL
- LQ3

#### Integral fitting construction

Hyper fitting/  
 Series LQ1, LQ2  
 LQ3 is used.



#### Piping from 8 directions are possible.

Pilot port

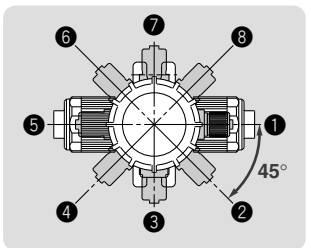

#### Integral fitting construction

Hyper fitting/Series LQ1, LQ3 is used.  
 Can select female thread.

### Space Saving Type

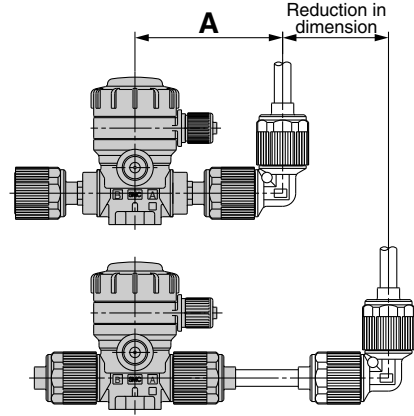

Model	A (mm)	Reduction in dimension (mm)
LVQ20	56.5	40.5 or more
LVQ30	70	49.5 or more
LVQ40	80	61.5 or more
LVQ50	104.5	64.5 or more
LVQ60	114.5	73.5 or more

#### Piping example

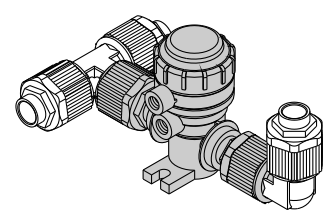

# ● Integral Fitting and Flare Integral Fitting Types Available

## Integral Fitting Type

Series LVQ-V/LVQ-S

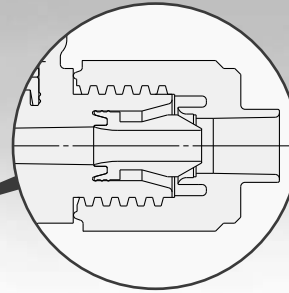
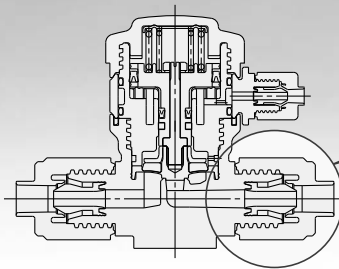

Hyper Fittings  
**Series LQ1**  
 (Series LVQ-V)  
**Series LQ2**  
 (Series LVQ-S)  
 • Insert bushing  
 • Quadruple sealing

## Flare Integral Fitting Type

Series LVQ-Z

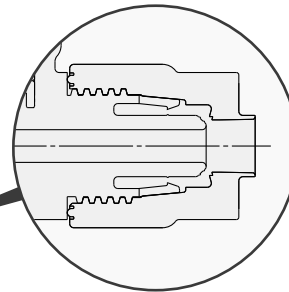
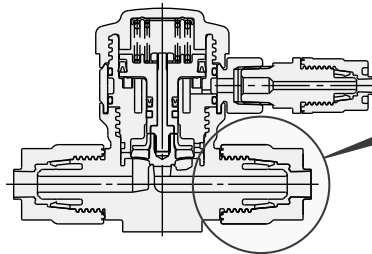

Hyper Fittings  
 Flare Type  
**Series LQ3**  
 • Flared grip  
 • Triple sealing

# ● Manual Type 2 Types of Handle Operation Selectable

### 90 Degree Turn Type



- Allows quick switching between valve open/close.

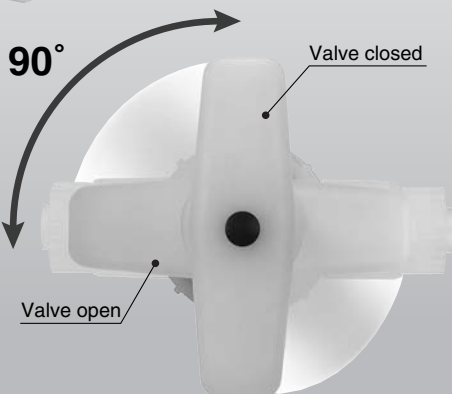

### Multi-Turn Type



- Prevents handle from idle turning at the final valve open/closed position and over-twisting.
- Indicator allows visual check of the open/close state of the valve.
- Locknut allows locking at desired open position.

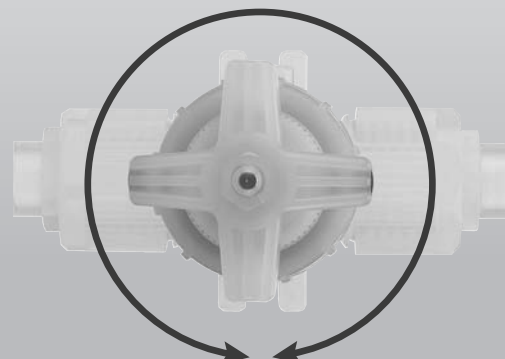



**Guide ring**

Eliminates lateral motion of the poppet which reduces internal leakage.

**Piston damper**

Absorbs piston momentum to minimize impact-induced particle generation.

**Buffer**

Protects diaphragm from deformation and damage due to back pressure.

**Integral fittings construction**

Offers quadruple seal construction. Nut lock mechanism—no additional tightening required. High flexural strength. Different tubing sizes can be selected.

**Diaphragm (PTFE)**

Special diaphragm construction ensures gentle opening and closing that prevents the formation of micro-bubbles.

**Minimal residual liquid**

Residual liquid is minimized by the tapered shape and integral fitting construction, allowing liquid to flow smoothly, achieving improved swept flow characteristics.

**Body (New PFA)**

Compatible with chemicals such as acids, bases and de-ionized water.

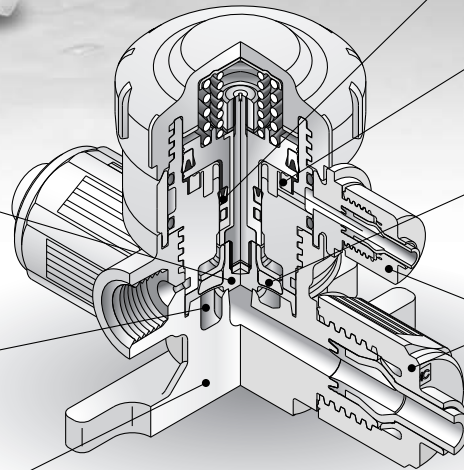

LVC

LVA

LVH

LVD

LVQ

LQ1

LVN

TL/TIL

LQ3

**Option**

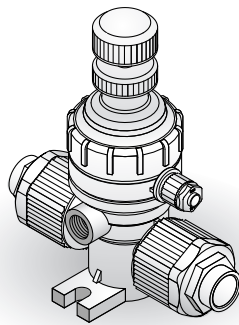

*With flow rate adjustment*

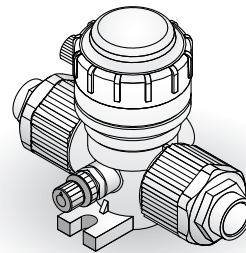

*With bypass*

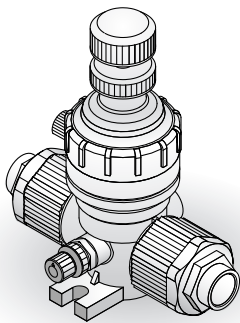

*With flow rate adjustment & bypass*

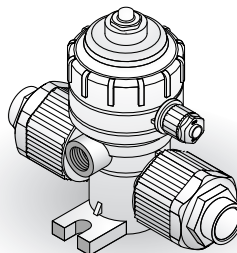

*With indicator*

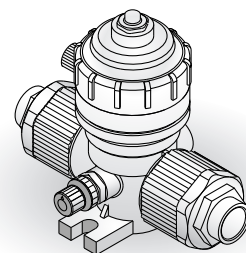

*With indicator & bypass*

# Variations

## Integral Fitting Type Series LVQ/LVQH

Orifice dia.	Flow characteristics Av x 10 <sup>-6</sup> m <sup>2</sup> (Cv)	Series	Applicable tubing O.D.														
			Metric sizes						Inch sizes								
			3	4	6	8	10	12	19	25	1/8	3/16	1/4	3/8	1/2	3/4	1
Series LVQ ø4	8.4 (0.35)	LVQ(H)20	●	●	○							●	●	○			
Series LVQH ø8	31.2 (1.3)	LVQ(H)30			●	●	○					●	○				
ø10	45.6 (1.9)	LVQ(H)40					●	○				●	○				
ø16	120 (5)	LVQ(H)50						●	○				●	○			
ø22	192 (8)	LVQ(H)60							●	○					●	○	

● With reducer ○ Basic size

## Integral Fitting Type Space saving/space saving connection Series LVQS/LVQHS

Orifice dia.	Flow characteristics Av x 10 <sup>-6</sup> m <sup>2</sup> (Cv)	Series	Fitting size					
			2	3	4	5	6	
Series LVQS ø4	8.4 (0.35)	LVQ(H)S20	●					
Series LVQHS ø8	31.2 (1.3)	LVQ(H)S30		●				
ø10	45.6 (1.9)	LVQ(H)S40			●			
ø16	120 (5)	LVQ(H)S50				●		
ø22	192 (8)	LVQ(H)S60					●	

## Flare Integral Fitting Type Series LVQ-Z/LVQH-Z

Orifice dia.	Flow characteristics Av x 10 <sup>-6</sup> m <sup>2</sup> (Cv)	Series	Applicable tubing O.D.														
			Metric sizes						Inch sizes								
			3	4	6	8	10	12	19	25	1/8	3/16	1/4	3/8	1/2	3/4	1
Series LVQ-Z ø4	8.4 (0.35)	LVQ20(H)-Z	●	●	●							●	●				
Series LVQH-Z ø8	31.2 (1.3)	LVQ30(H)-Z				●	●						●	○			
ø10	45.6 (1.9)	LVQ40(H)-Z					●	○					●	○			
ø16	120 (5)	LVQ50(H)-Z						●	○				●	○			
ø22	192 (8)	LVQ60(H)-Z							●	○					●	○	

## Flare Integral Fitting Type Space saving/space saving connection Series LVQS-Z/LVQHS-Z

Orifice dia.	Flow characteristics Av x 10 <sup>-6</sup> m <sup>2</sup> (Cv)	Series	Fitting size					
			2	3	4	5	6	
Series LVQS-Z ø4	8.4 (0.35)	LVQ20(H)S-Z	●					
Series LVQHS-Z ø8	31.2 (1.3)	LVQ30(H)S-Z		●				
ø10	45.6 (1.9)	LVQ40(H)S-Z			●			
ø16	120 (5)	LVQ50(H)S-Z				●		
ø22	192 (8)	LVQ60(H)S-Z					●	

## Tube Extension Fitting Type Series LVQ-T/LVQH-T

Orifice dia.	Flow characteristics Av x 10 <sup>-6</sup> m <sup>2</sup> (Cv)	Series	Tubing size												
			Metric sizes					Inch sizes							
			6	10	12	19	25	1/4	3/8	1/2	3/4	1			
Series LVQ-T ø4	8.4 (0.35)	LVQ20(H)-T	●					●							
Series LVQH-T ø8	31.2 (1.3)	LVQ30(H)-T		●					●						
ø10	45.6 (1.9)	LVQ40(H)-T			●					●					
ø16	120 (5)	LVQ50(H)-T				●					●				
ø22	192 (8)	LVQ60(H)-T					●					●			

# INDEX

## Integral Fitting Type

Air Operated Type  
Integral Fitting Type  
Hyper Fittings  
● **Series LVQ**

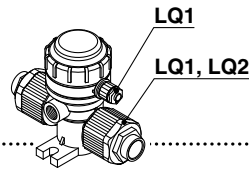

P.518

Air Operated Type  
Integral Fitting Type  
Space Saving/Space Saving Connection  
● **Series LVQS**

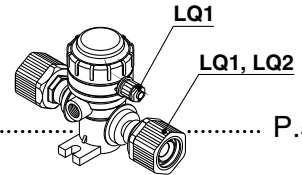

P.526

Manual Type  
Integral Fitting Type  
Hyper Fittings  
● **Series LVQH**

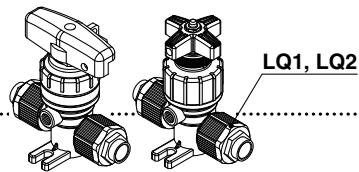

P.535

Manual Type  
Integral Fitting Type  
Space Saving/Space Saving Connection  
● **Series LVQHS**

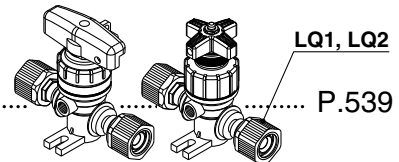

P.539

Fittings and Special Tools

P.544

## Flare Integral Fitting Type

Air Operated Type  
Flare Integral Fitting Type  
Hyper Fittings  
● **Series LVQ-Z**

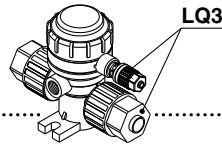

P.545

Air Operated Type  
Flare Integral Fitting Type  
Space Saving/Space Saving Connection  
● **Series LVQS-Z**

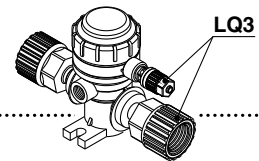

P.553

Manual Type  
Flare Integral Fitting Type  
Hyper Fittings  
● **Series LVQH-Z**

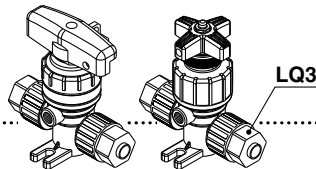

P.562

Manual Type  
Flare Integral Fitting Type  
Space Saving/Space Saving Connection  
● **Series LVQHS-Z**

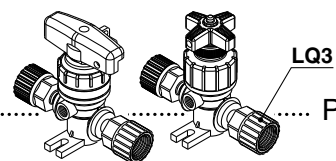

P.566

# INDEX

Tube Extension  
Fitting Type

**Air Operated Type  
Tube Extension Fitting Type**

● **Series LVQ-T**

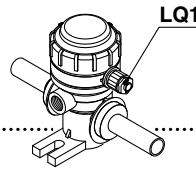

P.571

**Manual Type  
Tube Extension Fitting Type**

● **Series LVQH-T**

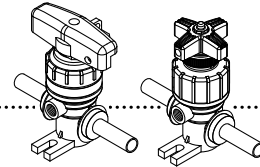

P.578

Integral  
Fitting Type

**Air Operated Type for Back Pressure 0.5 MPa  
Integral Fitting Type  
Hyper Fittings**

● **Series LVQ□□H**

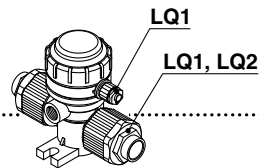

P.581

Flare Integral  
Fitting Type

**Air Operated Type for Back Pressure 0.5 MPa  
Flare Integral Fitting Type  
Hyper Fittings**

● **Series LVQ□□H-Z**

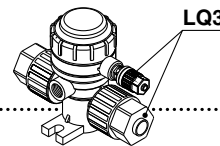

P.582

**Applicable Fluids**

P.584

**High Purity Chemical Valve Non-Metallic Exterior  
Specific Product Precautions**

P.585, 586

LVC

LVA

LVH

LVD

**LVQ**

LQ1

LVN

TL/TIL

LQ3

# Air Operated Type Integral Fitting Type (Hyper Fittings) Series **LVQ**

## How to Order

**LVQ 2 0 - S 07** [ ] [ ] [ ] [ ] **Option (2)**

### Body class

Symbol	Body class	Orifice dia.
2	2	ø4
3	3	ø8
4	4	ø10
5	5	ø16
6	6	ø22

### Valve type

0	N.C.
1	N.O.
2	Double acting

Note) Refer to variations in the table below for valve type combinations.

### Fitting type

Symbol	Fittings	Body class
V	LQ1	2, 3, 4, 5, 6
S	LQ2	2, 3, 4, 5

### Applicable tubing size

Symbol	Connecting tubing O.D.	Body class					
		2	3	4	5	6	
<b>Metric sizes</b>							
03	ø3	●					
04	ø4	●					
06	ø6	○	●				
08	ø8		●				
10	ø10		○	●			
12	ø12			○	●		
19	ø19				○	●	
25	ø25					○	
<b>Inch sizes</b>							
03	1/8	●					
05	3/16	●					
07	1/4	○	●				
11	3/8		○	●			
13	1/2			○	●		
19	3/4				○	●	
25	1					○	

○ Basic size ● With reducer

### Port B (OUT) different dia. size

Symbol	Application
Nil	Ports A & B same size
Refer to the applicable tubing table to the left.	Different diameter tubings can be selected within the same body class.

### Pilot port thread type

Nil	LQ1 integral fitting	Connection tubing O.D. 1/8" (ø3)
M	LQ1 integral fitting	Connection tubing O.D. ø4
R	Threaded	Rc 1/8
N	Threaded	NP T1/8

Symbol	Applicable option										Note	
	1	2	3	4	5	6	7	8	9	24		
Nil	○	○	○	○	○	○	○	○	○	○	—	—
J	○	—	—	—	○	○	—	—	—	—	—	For high temperature
K	○	○	○	○	○	○	○	○	○	○	○	Buffer material FFKM
N	○	○	○	○	○	○	○	○	○	○	○	For ammonium hydroxide
P	—	—	—	○	○	—	—	—	—	—	—	High flow spec. LVQ6□ only





### Option (1)

Nil	None	6	High back pressure with flow rate adjustment
1	With flow rate adjustment	7	High back pressure with bypass
2	With bypass	8	High back pressure with flow rate adjustment & bypass
3	With flow rate adjustment & bypass	9	High back pressure with indicator
4	With indicator	24	With indicator & bypass
5	High back pressure (0.42 MPa)		

Note) Options (2) cannot be combined with each other.

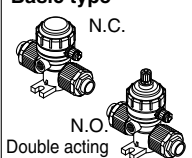
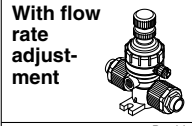
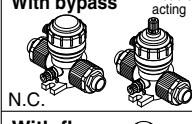
Note) Refer to variations in the table below for valve type and option (1) combinations. Options (1) can not be combined each other.

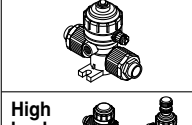
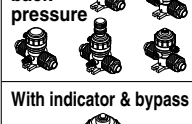
### Variations

Type	Symbol	Model	Orifice diameter				
			LVQ20	LVQ30	LVQ40	LVQ50	LVQ60
			Tubing outside dia.				
			Millimeter				
			Inch				
			Valve type				
<b>Basic type</b> 	N.C.	N.C.	○	○	○	○	○
	N.O.	N.O.	○	○	○	○	○
	Double acting	Double acting	○	○	○	○	○
<b>With flow rate adjustment</b> 	N.C.	N.C.	○	○	○	○	○
	N.C.	N.C.	○	○	○	○	○
<b>With bypass</b> 	N.C.	N.C.	○	○	○	○	○
	Double acting	Double acting	○	○	○	○	○
<b>With flow rate adjustment &amp; bypass</b> 	N.C.	N.C.	○	○	○	○	○
	N.C.	N.C.	○	○	○	○	○
<b>With indicator</b> 	N.C.	N.C.	○	○	○	○	○
	N.C.	N.C.	○	○	○	○	○
<b>High back pressure</b> 	N.C.	N.C.	○	○	○	○	○
	N.C.	N.C.	○	○	○	○	○
<b>With indicator &amp; bypass</b> 	N.C.	N.C.	○	○	○	○	○



## Standard Specifications



Model		LVQ20	LVQ30	LVQ40	LVQ50	LVQ60
Tubing O.D.	Metric size	6	10	12	19	25
	Inch size	1/4	3/8	1/2	3/4	1
Fitting type	IN/OUT port	LQ1 or LQ2				LQ1
	Pilot port	LQ1				
Orifice diameter		ø4	ø8	ø10	ø16	ø22
Flow characteristics	Av x 10 <sup>-6</sup> m <sup>2</sup>	8.4	31.2	45.6	120	192(228) <sup>Note)</sup>
	Cv	0.35	1.3	1.9	5	8(9.5) <sup>Note)</sup>
Withstand pressure (MPa)		1				
Operating pressure <A→B flow>	Standard	-98 kPa to 0.5 MPa			-98 kPa to 0.4 MPa	
	High temperature	-98 kPa to 0.3 MPa				
Back pressure (MPa)	Standard	0.3 or less			0.2 or less	
	High back pressure	0.42				
	High temperature	0.3 or less			0.2 or less	
Valve leakage (cm <sup>3</sup> /min)		0 (With water pressure)				
Pilot air pressure (MPa)		0.3 to 0.5 (High back pressure: 0.45 to 0.55)				
Pilot port size		1/8" (ø3), ø4, Rc 1/8, NPT 1/8				
Fluid temperature (°C)	Standard	0 to 100				
	High temperature	0 to 170				
Ambient temperature (°C)		0 to 60				
Mass (kg)		0.08	0.17	0.22	0.70	0.81

Note) ( ) is high flow specification.

## Different Diameter Tubing Applicable with Reducer

Different diameter tubing can be selected (within a body class) by using a nut and insert bushing (reducer). ● With reducer

Body class	Tubing O.D.														
	Metric sizes							Inch sizes							
	3	4	6	8	10	12	19	25	1/8	3/16	1/4	3/8	1/2	3/4	1
2	●	●	○	—	—	—	—	—	●	●	○	—	—	—	—
3	—	—	●	●	○	—	—	—	—	—	●	○	—	—	—
4	—	—	—	—	●	○	—	—	—	—	—	●	○	—	—
5	—	—	—	—	—	●	○	—	—	—	—	—	●	○	—
6	—	—	—	—	—	—	●	○	—	—	—	—	—	●	○

Note) Refer to page 544 for information on changing tubing sizes.

## ⚠ Specific Product Precautions

Be sure to read before handling. Refer to front matters 42 and 43 for Safety Instructions, and pages 585 and 586 for High Purity Chemical Valve Non-Metallic Exterior Precautions.

### Piping

#### ⚠ Caution

1. Connect tubing with special tools.

Refer to the pamphlet "High-Purity Fluoropolymer Fittings HYPER FITTING®/Series LQ1, 2 Work Procedure Instructions" (M-E05-1) for connecting tubing and special tools. (Downloadable from our web site.)

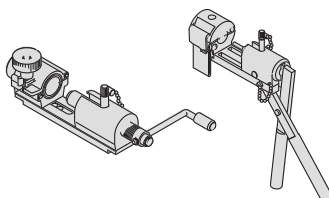

#### ⚠ Caution

2. Tighten the nut to the end surface of the body. As a guide, refer to the proper tightening torques shown below.

#### Tightening torque for piping

Body class	Torque (N·m)	
	LQ1	LQ2
2	0.3 to 0.4	1.5 to 2.0
3	0.8 to 1.0	3.0 to 3.5
4	1.0 to 1.2	7.5 to 9.0
5	2.5 to 3.0	11.0 to 13.0
6	5.5 to 6.0	—



# Series LVQ

## Construction

Basic type

N.C. type

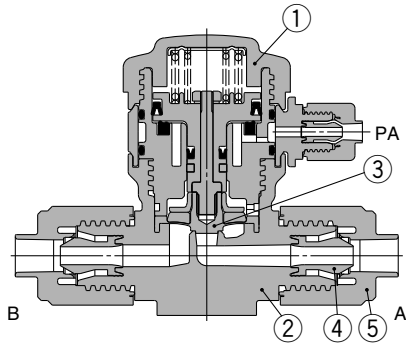

N.O. type

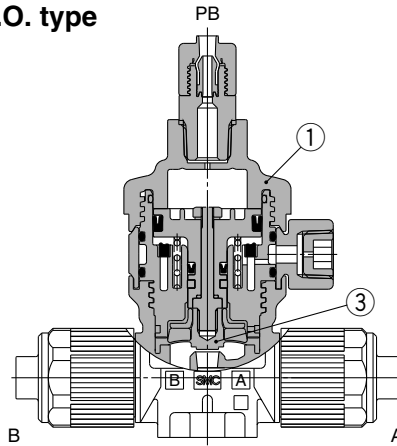

Double acting type

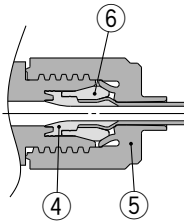
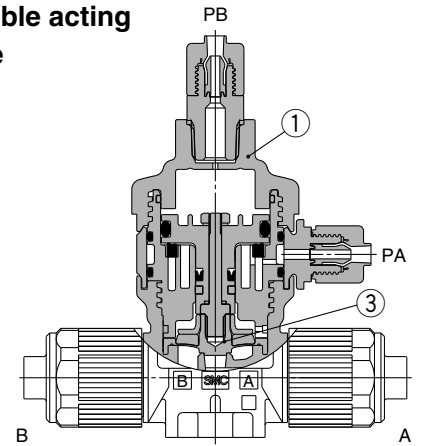

With reducer

With flow rate adjustment

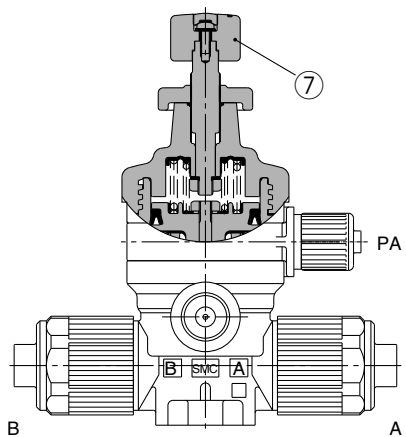

With bypass

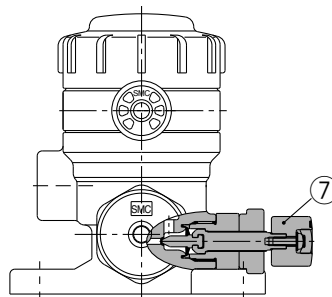

With indicator

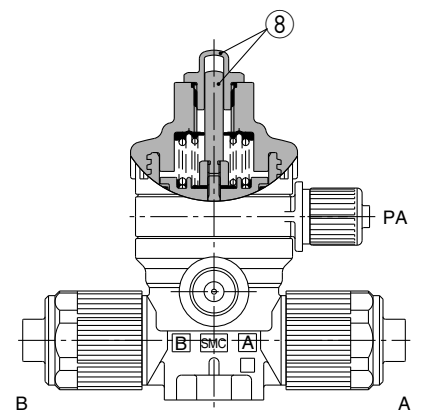

### Parts list

No.	Description	Material
1	Actuator section	PVDF
2	Body	PFA
3	Diaphragm	PTFE
4	Insert bushing	PFA
5	Nut	PFA
6	Collar	PFA
7	Flow rate adjuster section	PVDF
8	Indicator, cover	PP

## Dimensions

Basic type, High back pressure spec.  
N.C. valve

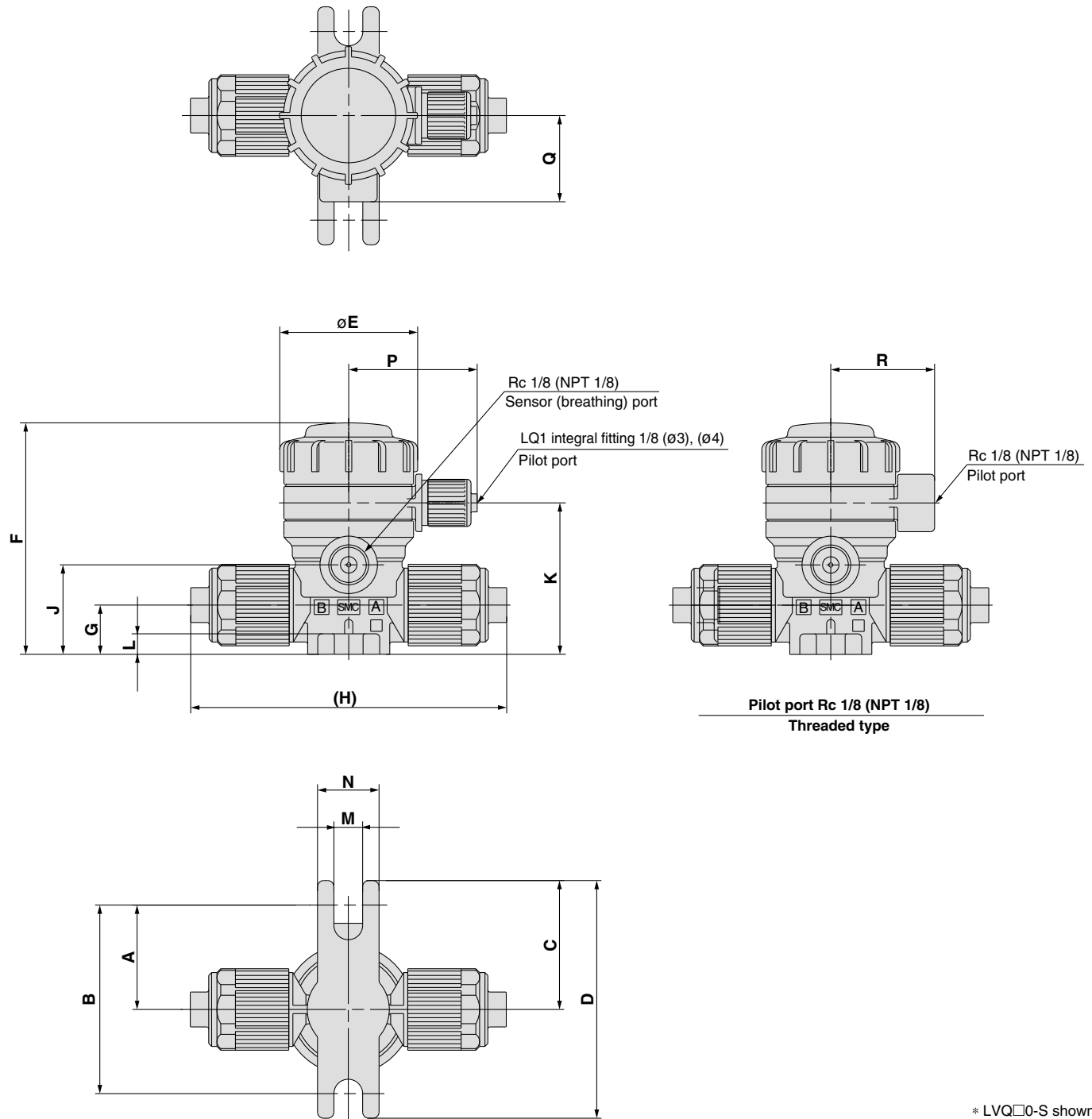

LVC

LVA

LVH

LVD

**LVQ**

LQ1

LVN

TL/TIL

LQ3

\* LVQ□0-S shown.

LVQ□0- $\frac{V}{S}$ □ Dimensions (N.C. valve)

(mm)

Model	A	B	C	D	E	F	G	H		J	K	L	M	N	P	Q	R
								V□	S□								
LVQ20- $\frac{V}{S}$ □	25.5	46	31.5	58	33.6	56.5	12	70	77	21.8	37	5	7	15	31.3	21	25.3
LVQ30- $\frac{V}{S}$ □	28.5	57	34.5	69	45.4	77	16.5	83	95	32	50	6	7	20	37.2	25	31.2
LVQ40- $\frac{V}{S}$ □	28.5	57	34.5	69	45.4	82.5	22	95	109	37.5	55.5	6	7	20	37.2	25	31.2
LVQ50- $\frac{V}{S}$ □	42	84	48	96	75	127	25	130	141	50.2	78.2	10	7	20	50.8	38.5	45
LVQ60-V□*	42	84	48	96	75	136.8	32	150	—	60	88	10	7	20	50.8	38.5	45

\* LVQ60 available only as "V".

# Series LVQ

## Dimensions

With flow rate adjustment, High back pressure spec. with flow rate adjustment

N.C. valve

Dimensions (mm)	
Model	S
LVQ20- $\frac{V}{S}$ □-1	83
LVQ30- $\frac{V}{S}$ □-1	113.5
LVQ40- $\frac{V}{S}$ □-1	119
LVQ50- $\frac{V}{S}$ □-1	171.5
LVQ60-V□-1*	182.5

\* LVQ60 available only as "V".

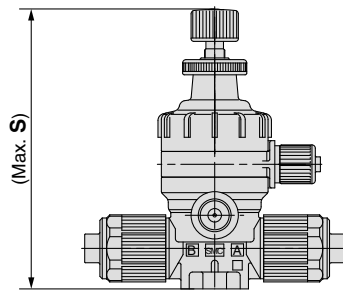

With bypass, High back pressure spec. with bypass

N.C. valve

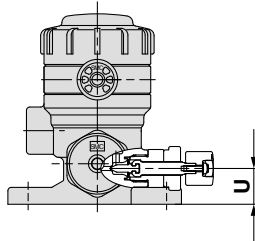
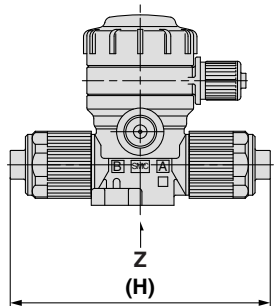
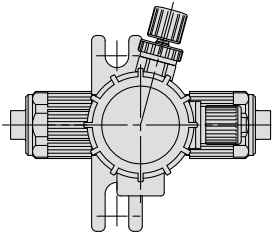

LVQ20

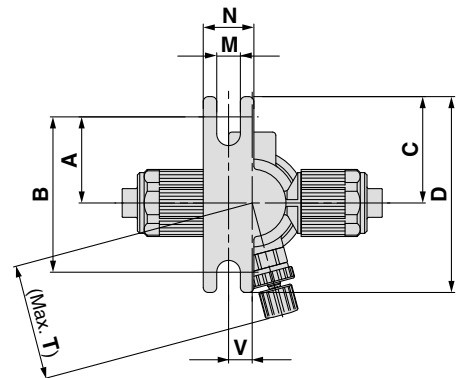

LVQ30, LVQ40  
LVQ50, LVQ60

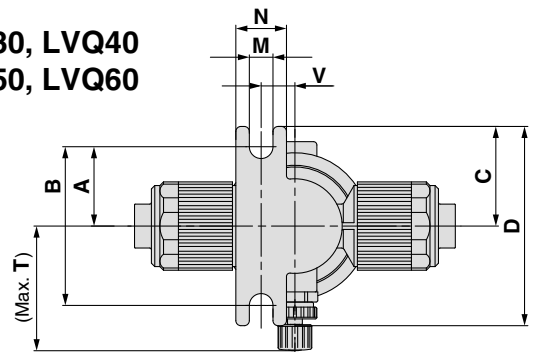

View Z

\* LVQ□0-S shown.

Model	A	B	C	D	M	N	T	U	V	H (mm)	
										V□	S□
LVQ20- $\frac{V}{S}$ □-2	25.5	46	31.5	58	7	15	34.3	10.6	7	64	77
LVQ30- $\frac{V}{S}$ □-2	25.5	51	31.5	63	7	15	36.9	16.5	10	83	95
LVQ40- $\frac{V}{S}$ □-2	25.5	51	31.5	63	7	15	37.9	22	10	95	109
LVQ50- $\frac{V}{S}$ □-2	38	76	44	88	7	20	64	25	17	130	141
LVQ60-V□-2*	38	76	44	88	7	20	66	32	17	150	—

\* LVQ60 available only as "V".

With flow rate adjustment & bypass  
High back pressure spec. with flow rate adjustment & bypass  
N.C. valve

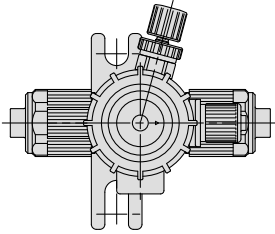

LVQ20

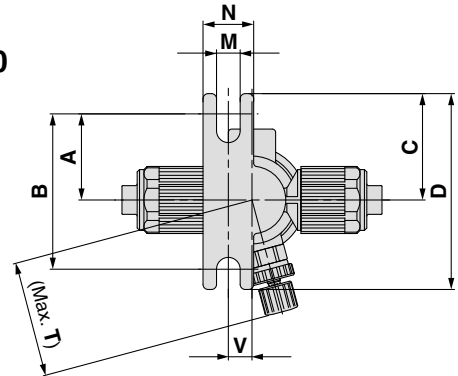

LVC

LVA

LVH

LVD

**LVQ**

LQ1

LVN

TL/TIL

LQ3

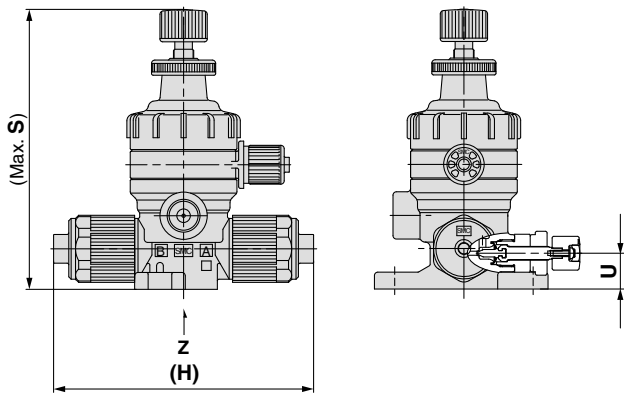

LVQ30, LVQ40  
LVQ50, LVQ60

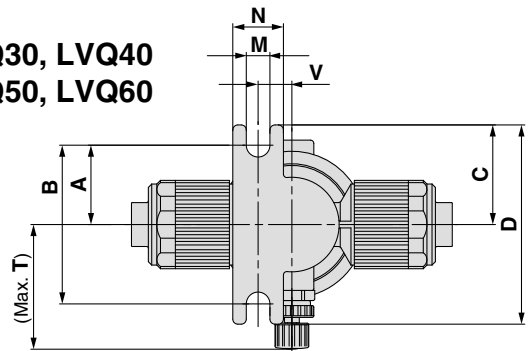

View Z

\* LVQ□0-S shown.

**Dimensions**

(mm)

Model	A	B	C	D	M	N	S	T	U	V	H	
											V□	S□
LVQ20- $\frac{3}{8}$ □-3	25.5	46	31.5	58	7	15	83	34.3	10.6	7	64	77
LVQ30- $\frac{3}{8}$ □-3	25.5	51	31.5	63	7	15	113.5	36.9	16.5	10	83	95
LVQ40- $\frac{3}{8}$ □-3	25.5	51	31.5	63	7	15	119	37.9	22	10	95	109
LVQ50- $\frac{3}{8}$ □-3	38	76	44	88	7	20	171.5	64	25	17	130	141
LVQ60-V□-3*	38	76	44	88	7	20	182.5	66	32	17	150	-

\* LVQ60 available only as "V".

With indicator, High back pressure spec. with indicator  
N.C. valve

**Dimensions**

(mm)

Model	S
LVQ20- $\frac{3}{8}$ □-4	70.5
LVQ30- $\frac{3}{8}$ □-4	88.5
LVQ40- $\frac{3}{8}$ □-4	94
LVQ50- $\frac{3}{8}$ □-4	134.5
LVQ60-V□-4*	144

\* LVQ60 available only as "V".

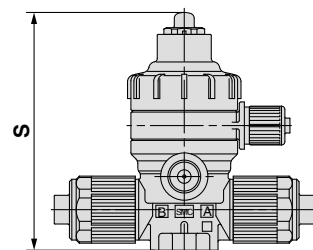

\* LVQ□0-S shown.

# Series LVQ

## Dimensions

### Basic type N.O. valve

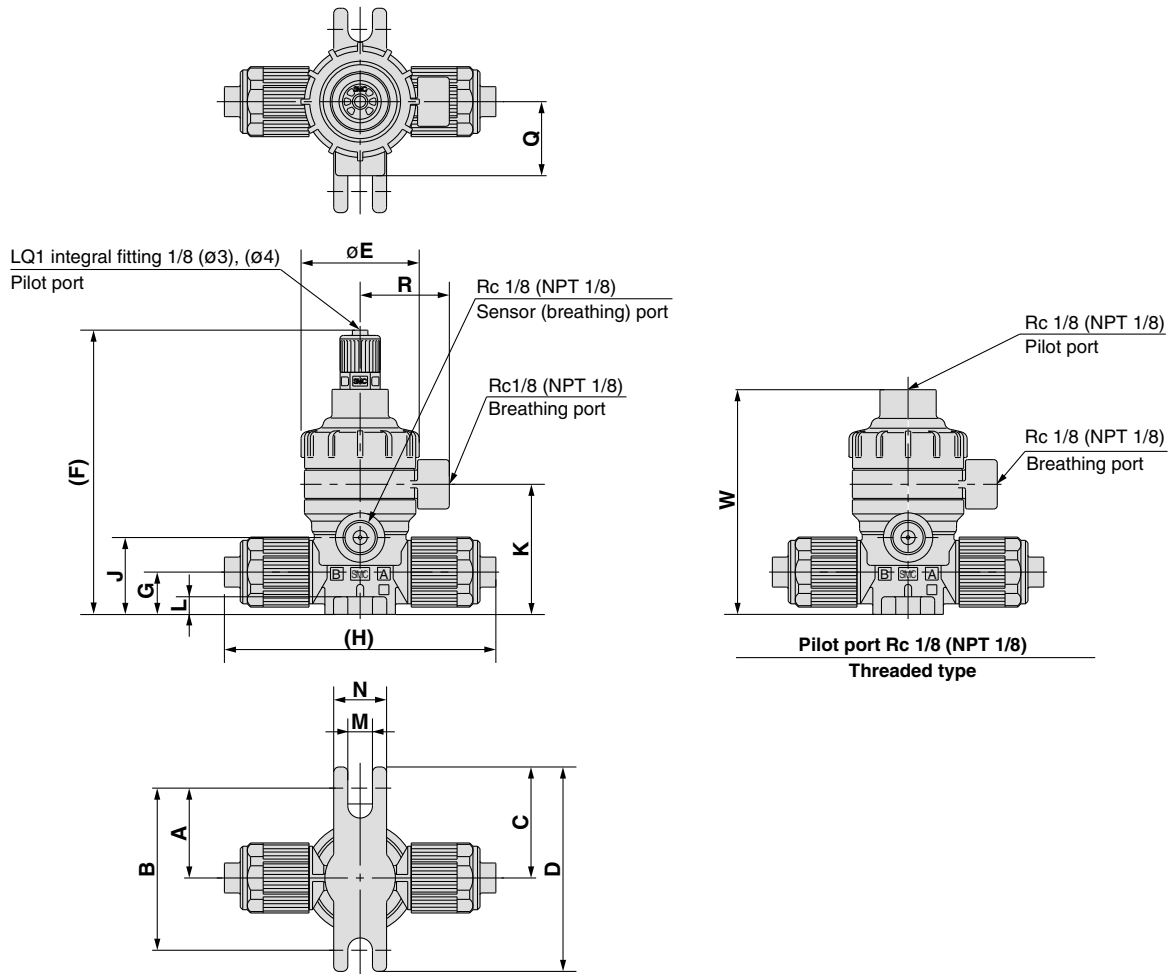

\* LVQ□0-S shown.

### Double acting valve

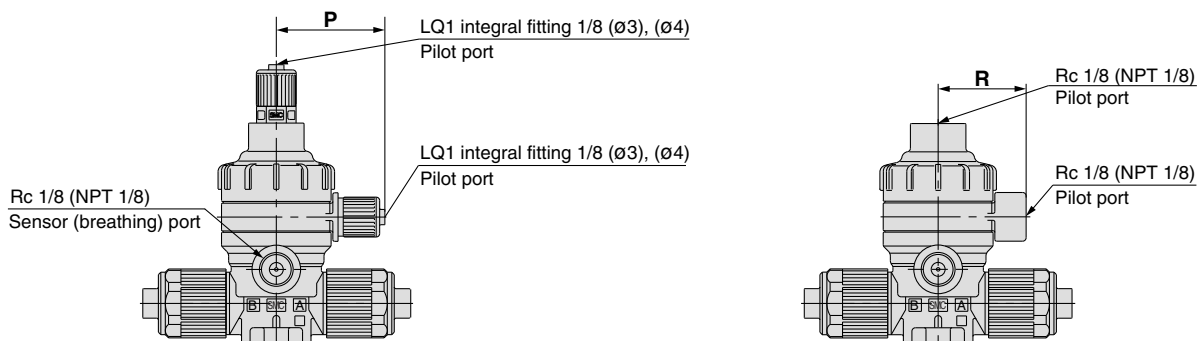

\* LVQ□0-S shown.

### LVQ□<sub>2</sub><sup>1</sup>-V<sub>s</sub>□ Dimensions (N.O. valve, double acting valve)

(mm)

Model	A	B	C	D	E	F	G	H		J	K	L	M	N	P	Q	R	W
								V□	S□									
LVQ2 <sup>1</sup> <sub>2</sub> -V□	25.5	46	31.5	58	33.6	81	12	70	77	21.8	37	5	7	15	31.3	21	25.3	64
LVQ3 <sup>1</sup> <sub>2</sub> -V□	28.5	57	34.5	69	45.4	99	16.5	83	95	32	50	6	7	20	37.2	25	31.2	82
LVQ4 <sup>1</sup> <sub>2</sub> -V□	28.5	57	34.5	69	45.4	104.5	22	95	109	37.5	55.5	6	7	20	37.2	25	31.2	87.5
LVQ5 <sup>1</sup> <sub>2</sub> -V□	42	84	48	96	75	145	25	130	141	50.2	78.2	10	7	20	50.8	38.5	45	128
LVQ6 <sup>1</sup> <sub>2</sub> -V□*	42	84	48	96	75	154.5	32	150	—	60	88	10	7	20	50.8	38.5	45	137.5

\* LVQ60 available only as "V".

With bypass  
Double acting valve

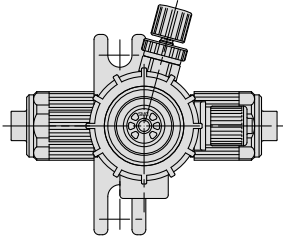

LVQ2<sup>1</sup>/<sub>2</sub>

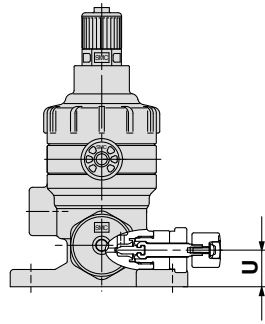
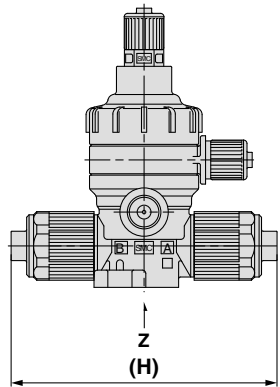
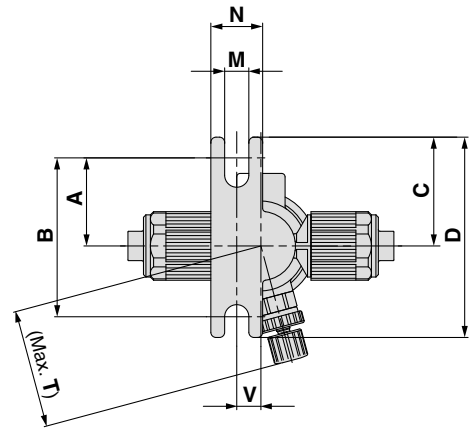

LVQ3<sup>1</sup>/<sub>2</sub>, LVQ4<sup>1</sup>/<sub>2</sub>  
LVQ5<sup>1</sup>/<sub>2</sub>, LVQ6<sup>1</sup>/<sub>2</sub>

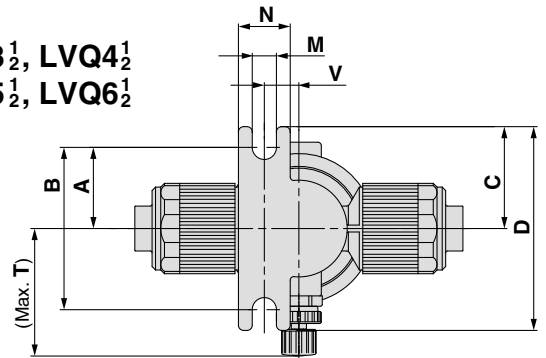

View Z

LVC

LVA

LVH

LVD

**LVQ**

LQ1

LVN

TL/TIL

LQ3

\* LVQ□0-S shown.

Dimensions (N.O valve, double acting valve)

(mm)

Model	A	B	C	D	M	N	T	U	V	H	
										V□	S□
LVQ2 <sup>1</sup> / <sub>2</sub> -V□-2	25.5	46	31.5	58	7	15	34.3	10.6	7	64	77
LVQ3 <sup>1</sup> / <sub>2</sub> -V□-2	25.5	51	31.5	63	7	15	36.9	16.5	10	83	95
LVQ4 <sup>1</sup> / <sub>2</sub> -V□-2	25.5	51	31.5	63	7	15	37.9	22	10	95	109
LVQ5 <sup>1</sup> / <sub>2</sub> -V□-2	38	76	44	88	7	20	64	25	17	130	141
LVQ6 <sup>1</sup> / <sub>2</sub> -V□-2*	38	76	44	88	7	20	66	32	17	150	—

\* LVQ60 available only as "V".

# Air Operated Type Integral Fitting Type Space Saving/Space Saving Connection Series **LVQS**

## How to Order

LVQ **2** **0** **S** - **S** **07**    -    -    - **Option (2)**

### Body class

Symbol	Body class	Orifice dia.
2	2	ø4
3	3	ø8
4	4	ø10
5	5	ø16
6	6	ø22

### Valve type

0	N.C.
1	N.O.
2	Double acting

Note) Refer to variations in the table below for valve type combinations.

### Body type

S	Space saving connection
---	-------------------------

### Fitting type

Symbol	Fittings	Body class
V	LQ1	2, 3, 4, 5, 6
S	LQ2	2, 3, 4, 5

### Applicable fitting size

Symbol	Fitting size	Body class					
		2	3	4	5	6	
07	2	○					
11	3		○				
13	4			○			
19	5				○		
25	6					○	

Note) Refer to page 527 for How to order fitting parts. Select the fittings of the same size as the one at the valve side.

### Pilot port thread type

Nil	LQ1 integral fitting	Connection tubing O.D. 1/8" (ø3)
M	LQ1 integral fitting	Connection tubing O.D. ø4
R	Threaded	Rc 1/8
N	Threaded	NP T1/8

Symbol	Applicable option										Note	
	1	2	3	4	5	6	7	8	9	24		
Nil	○	○	○	○	○	○	○	○	○	○	—	—
J	○	—	—	—	○	○	—	—	—	—	—	For high temperature
K	○	○	○	○	○	○	○	○	○	○	○	Buffer material FFKM
N	○	○	○	○	○	○	○	○	○	○	○	For ammonium hydroxide
P	—	—	—	○	○	—	—	—	—	—	—	High flow spec. LVQ6□ only

Note) Options (2) cannot be combined with each other.

### Option (1)

Nil	None	6	High back pressure with flow rate adjustment
1	With flow rate adjustment	7	High back pressure with bypass
2	With bypass	8	High back pressure with flow rate adjustment & bypass
3	With flow rate adjustment & bypass	9	High back pressure with indicator
4	With indicator	24	With indicator & bypass
5	High back pressure (0.42 MPa)		

Note) Refer to variations in the table below for valve type and option (1) combinations. Options (1) can not be combined each other.

### Variations

Type	Symbol	Model	LVQ20	LVQ30	LVQ40	LVQ50	LVQ60
			Orifice diameter Applicable fitting size	ø4	ø8	ø10	ø16
<b>Basic type</b> N.C.		N.C.	○	○	○	○	○
N.O.		○	○	○	○	○	
Double acting		○	○	○	○	○	
<b>With flow rate adjustment</b>		N.C.	○	○	○	○	○
<b>With bypass</b>		N.C.	○	○	○	○	○
		Double acting	○	○	○	○	○
<b>With flow rate adjustment &amp; bypass</b>		N.C.	○	○	○	○	○
<b>With indicator</b>		N.C.	○	○	○	○	○
<b>High back pressure</b>		N.C.	○	○	○	○	○
<b>With indicator &amp; bypass</b>		N.C.	○	○	○	○	○



## How to Order Fittings for Space Saving

### Applicable tubing size

Size	No.	Applicable tubing size (mm)	Reducing
2	1	6 x 4	○
2	2	4 x 3	●
3	1	10 x 8	○
3	2	8 x 6	●
3	3	6 x 4	●
4	1	12 x 10	○
4	2	10 x 8	●
5	1	19 x 16	○
5	2	12 x 10	●
6	1	25 x 22	○
6	2	19 x 16	●

Size	Symbol	Applicable tubing size (inch)	Reducing
2	A	1/4" x 5/32"	○
2	B	3/16" x 1/8"	●
2	C	1/8" x 0.086"	●
3	A	3/8" x 1/4"	○
3	B	1/4" x 5/32"	●
4	A	1/2" x 3/8"	○
4	B	3/8" x 1/4"	●
5	A	3/4" x 5/8"	○
5	B	1/2" x 3/8"	●
6	A	1" x 7/8"	○
6	B	3/4" x 5/8"	●

○ Basic size ● With reducer

🔍 Note 1) Select a fitting the same size as the valve fitting.

LQ1 E 61 - S  
LQ2 E 21 - S

• One nut (including insert bushing) of the nuts is not attached.

### Type of fitting

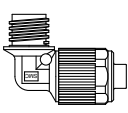
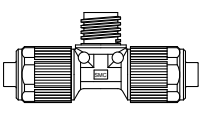
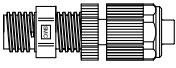
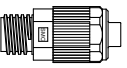
E	T
Union elbow 	Union tee 
P	U
Panel mount union 	Union 

### Applicable tubing size

Size	No.	Applicable tubing size (mm)	Reducing
2	1	6 x 4	○
2	2	4 x 3	●
3	1	10 x 8	○
3	2	8 x 6	●
3	3	6 x 4	●
4	1	12 x 10	○
4	2	10 x 8	●
5	1	19 x 16	○
5	2	12 x 10	●

Size	Symbol	Applicable tubing size (inch)	Reducing
2	A	1/4" x 5/32"	○
2	B	3/16" x 1/8"	●
2	C	1/8" x 0.086"	●
3	A	3/8" x 1/4"	○
3	B	1/4" x 5/32"	●
4	A	1/2" x 3/8"	○
4	B	3/8" x 1/4"	●
5	A	3/4" x 5/8"	○
5	B	1/2" x 3/8"	●

○ Basic size ● With reducer

🔍 Note 1) Select a fitting the same size as the valve fitting.

## Piping example

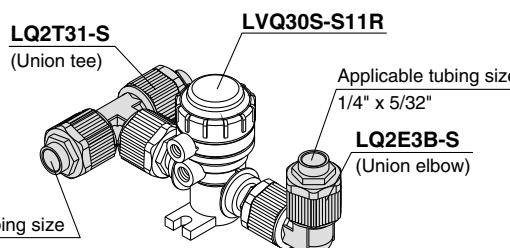

Applicable tubing size  
10 x 8

**Example**

<b>LVQ30S-S11R</b>	1
<b>LQ2T31-S</b> (Union tee)	1
<b>LQ2E3B-S</b> (Union elbow)	1

Note) For shipment, the valve and fittings are individually packaged and dispatched together in 1 box.



## Standard Specifications

Model		LVQ20S	LVQ30S	LVQ40S	LVQ50S	LVQ60S
Connection fitting size		2	3	4	5	6
Fitting type	IN/OUT port	LQ1 or LQ2				LQ1
	Pilot port	LQ1				
Orifice diameter		ø4	ø8	ø10	ø16	ø22
Flow characteristics	Av x 10 <sup>-6</sup> m <sup>2</sup>	8.4	31.2	45.6	120	192 (228) <sup>Note)</sup>
	Cv	0.35	1.3	1.9	5	8 (9.5) <sup>Note)</sup>
Withstand pressure (MPa)		1				
Operating pressure <A→B flow>	Standard	-98 kPa to 0.5 MPa			-98 kPa to 0.4 MPa	
	High temperature	-98 kPa to 0.3 MPa				
Back pressure (MPa)	Standard	0.3 or less			0.2 or less	
	High back pressure	0.42				
	High temperature	0.3 or less			0.2 or less	
Valve leakage (cm <sup>3</sup> /min)		0 (with water pressure)				
Pilot air pressure (MPa)		0.3 to 0.5 (High back pressure: 0.45 to 0.55)				
Pilot port size		1/8" (ø3), ø4, Rc 1/8, NPT 1/8				
Fluid temperature (°C)	Standard	0 to 100				
	High temperature	0 to 170				
Ambient temperature (°C)		0 to 60				
Mass (kg)		0.085	0.175	0.223	0.725	0.835

Note) ( ) is high flow specification.

## ⚠ Specific Product Precautions

Be sure to read before handling. Refer to front matters 42 and 43 for Safety Instructions, and pages 585 and 586 for High Purity Chemical Valve Non-Metallic Exterior Precautions.

### Piping

## ⚠ Caution

1. Take extra care with the insert bushing when connecting the fittings.
2. Tighten the nut to the end surface of the body. As a guide, refer to the proper tightening torques shown below.

#### Tightening torque for piping

Body class	Torque (N·m)	
	LQ1	LQ2
2	0.3 to 0.4	1.5 to 2.0
3	0.8 to 1.0	3.0 to 3.5
4	1.0 to 1.2	7.5 to 9.0
5	2.5 to 3.0	11.0 to 13.0
6	5.5 to 6.0	—

## Construction

Basic type  
N.C. type

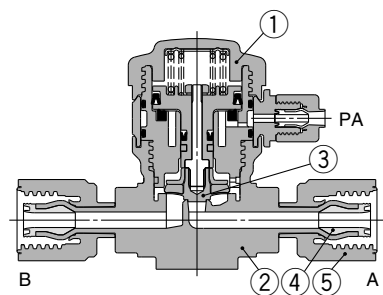

N.O. type

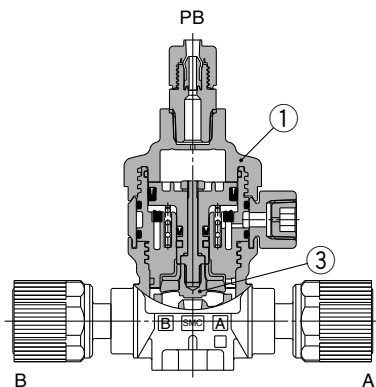

Double acting type

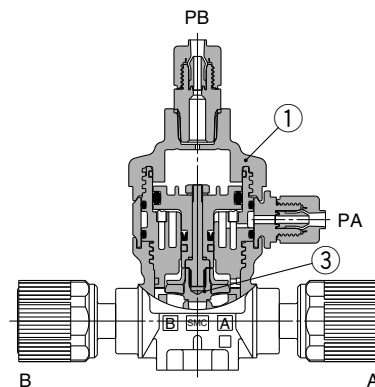

With flow rate adjustment

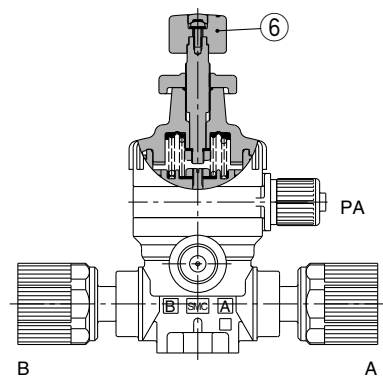

With bypass

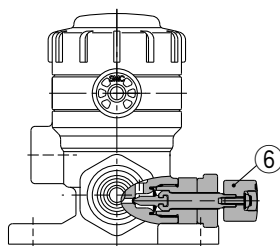

With indicator

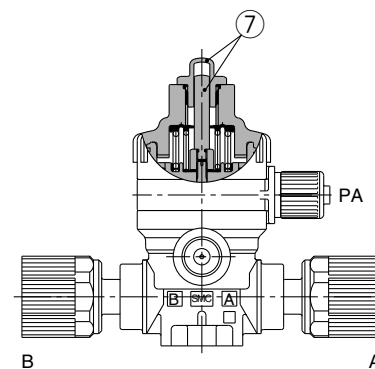

LVC

LVA

LVH

LVD

**LVQ**

LQ1

LVN

TL/TIL

LQ3

### Parts list

No.	Description	Material
1	Actuator section	PVDF
2	Body	PFA
3	Diaphragm	PTFE
4	Insert bushing	PFA
5	Nut	PFA
6	Flow rate adjuster section	PVDF
7	Indicator, cover	PP

# Series LVQS

## Dimensions

Basic type, High back pressure spec.  
N.C. valve

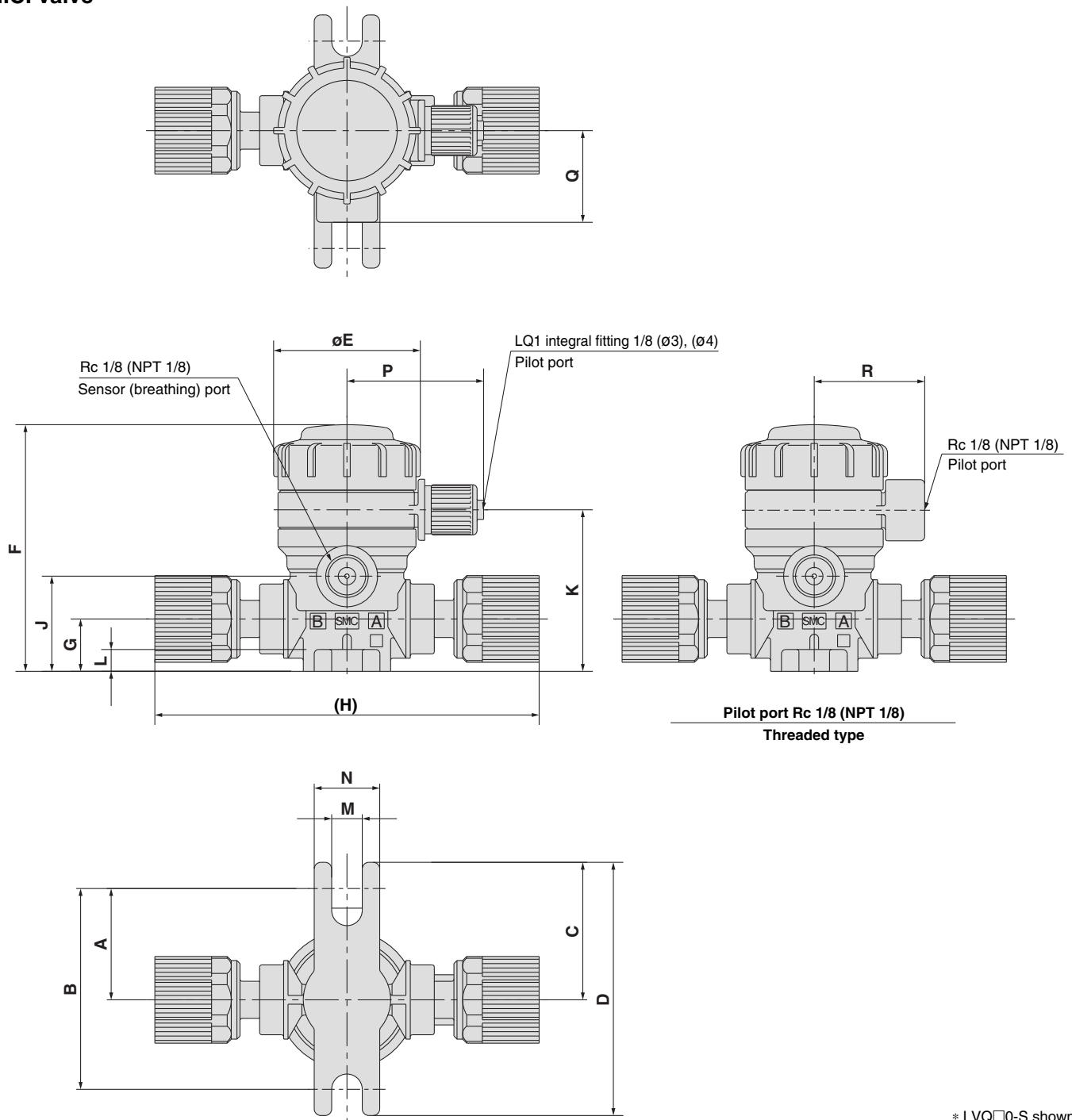

\* LVQ□0-S shown.

### LVQ□0S-V□□ Dimensions (N.C. valve)

(mm)

Model	A	B	C	D	E	F	G	H		J	K	L	M	N	P	Q	R
								V□	S□								
LVQ20S-V <sup>0</sup> 07	25.5	46	31.5	58	33.6	56.5	12	89	92	21.8	37	5	7	15	31.3	21	25.3
LVQ30S-V <sup>0</sup> 11	28.5	57	34.5	69	45.4	77	16.5	106	112	32	50	6	7	20	37.2	25	31.2
LVQ40S-V <sup>0</sup> 13	28.5	57	34.5	69	45.4	82.5	22	120	126	37.5	55.5	6	7	20	37.2	25	31.2
LVQ50S-V <sup>0</sup> 19	42	84	48	96	75	127	25	164	168	50.2	78.2	10	7	20	50.8	38.5	45
LVQ60S-V25*	42	84	48	96	75	136.8	32	177	—	60	88	10	7	20	50.8	38.5	45

\* LVQ60 available only as "V".

With flow rate adjustment, High back pressure spec. with flow rate adjustment

N.C. valve

Dimensions (mm)	
Model	S
LVQ20S- $\frac{V}{S}$ 07-1	83
LVQ30S- $\frac{V}{S}$ 11-1	113.5
LVQ40S- $\frac{V}{S}$ 13-1	119
LVQ50S- $\frac{V}{S}$ 19-1	171.5
LVQ60S-V25-1*	182.5

\* LVQ60 available only as "V".

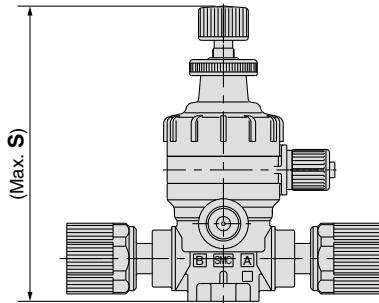

\* LVQ□0-S shown.

With bypass, High back pressure spec. with bypass

N.C. valve

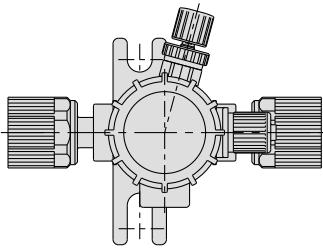

LVQ20S

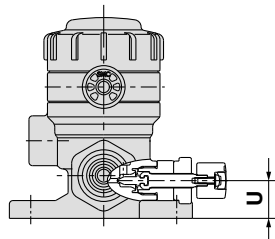
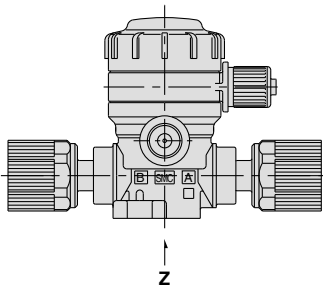
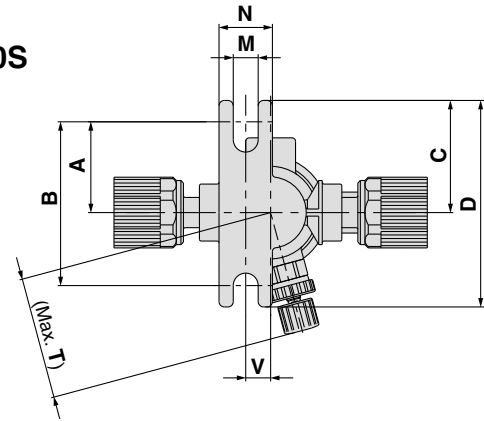

LVQ30S, LVQ40S  
LVQ50S, LVQ60S

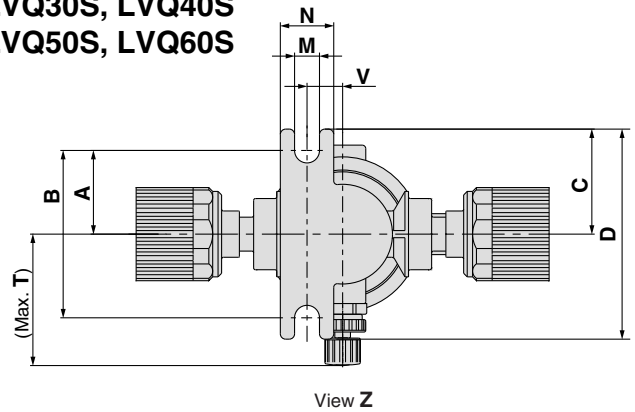

Dimensions (mm)									
Model	A	B	C	D	M	N	T	U	V
LVQ20S- $\frac{V}{S}$ 07-2	25.5	46	31.5	58	7	15	34.3	10.6	7
LVQ30S- $\frac{V}{S}$ 11-2	25.5	51	31.5	63	7	15	36.9	16.5	10
LVQ40S- $\frac{V}{S}$ 13-2	25.5	51	31.5	63	7	15	37.9	22	10
LVQ50S- $\frac{V}{S}$ 19-2	38	76	44	88	7	20	64	25	17
LVQ60S-V25-2*	38	76	44	88	7	20	66	32	17

\* LVQ60 available only as "V".

\* LVQ□0-S shown.

LVC

LVA

LVH

LVD

LVQ

LQ1

LVN

TL/TIL

LQ3

# Series LVQS

## Dimensions

With flow rate adjustment & bypass  
High back pressure spec.  
with flow rate adjustment & bypass  
N.C. valve

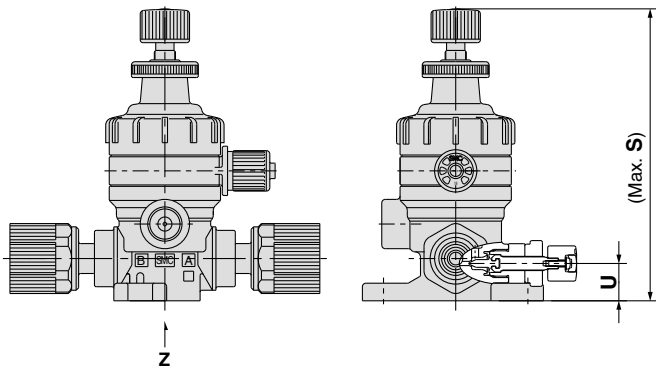
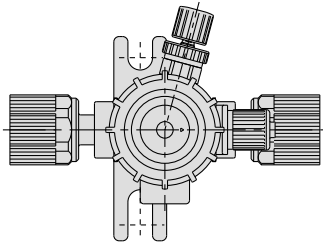

LVQ20S

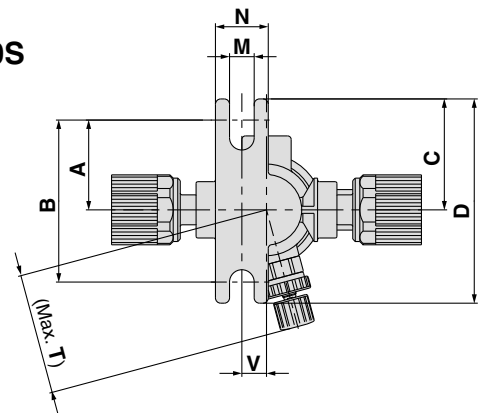

LVQ30S, LVQ40S  
LVQ50S, LVQ60S

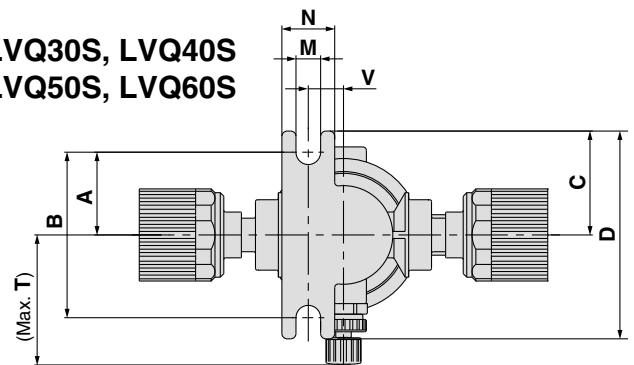

View Z

\* LVQ□0-S shown.

Dimensions		(mm)								
Model	A	B	C	D	M	N	S	T	U	V
LVQ20S- <sup>V</sup> 07-3	25.5	46	31.5	58	7	15	83	34.3	10.6	7
LVQ30S- <sup>V</sup> 11-3	25.5	51	31.5	63	7	15	113.5	36.9	16.5	10
LVQ40S- <sup>V</sup> 13-3	25.5	51	31.5	63	7	15	119	37.9	22	10
LVQ50S- <sup>V</sup> 19-3	38	76	44	88	7	20	171.5	64	25	17
LVQ60S-V25-3*	38	76	44	88	7	20	182.5	66	32	17

\* LVQ60 available only as "V".

With indicator, High back pressure spec. with indicator  
N.C. valve

Dimensions		(mm)
Model	S	
LVQ20S- <sup>V</sup> 07-4	70.5	
LVQ30S- <sup>V</sup> 11-4	88.5	
LVQ40S- <sup>V</sup> 13-4	94	
LVQ50S- <sup>V</sup> 19-4	134.5	
LVQ60S-V25-4*	144	

\* LVQ60 available only as "V".

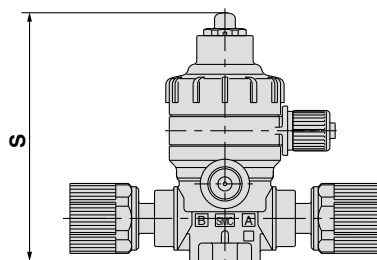

\* LVQ□0-S shown.

**Basic type  
N.O. valve**

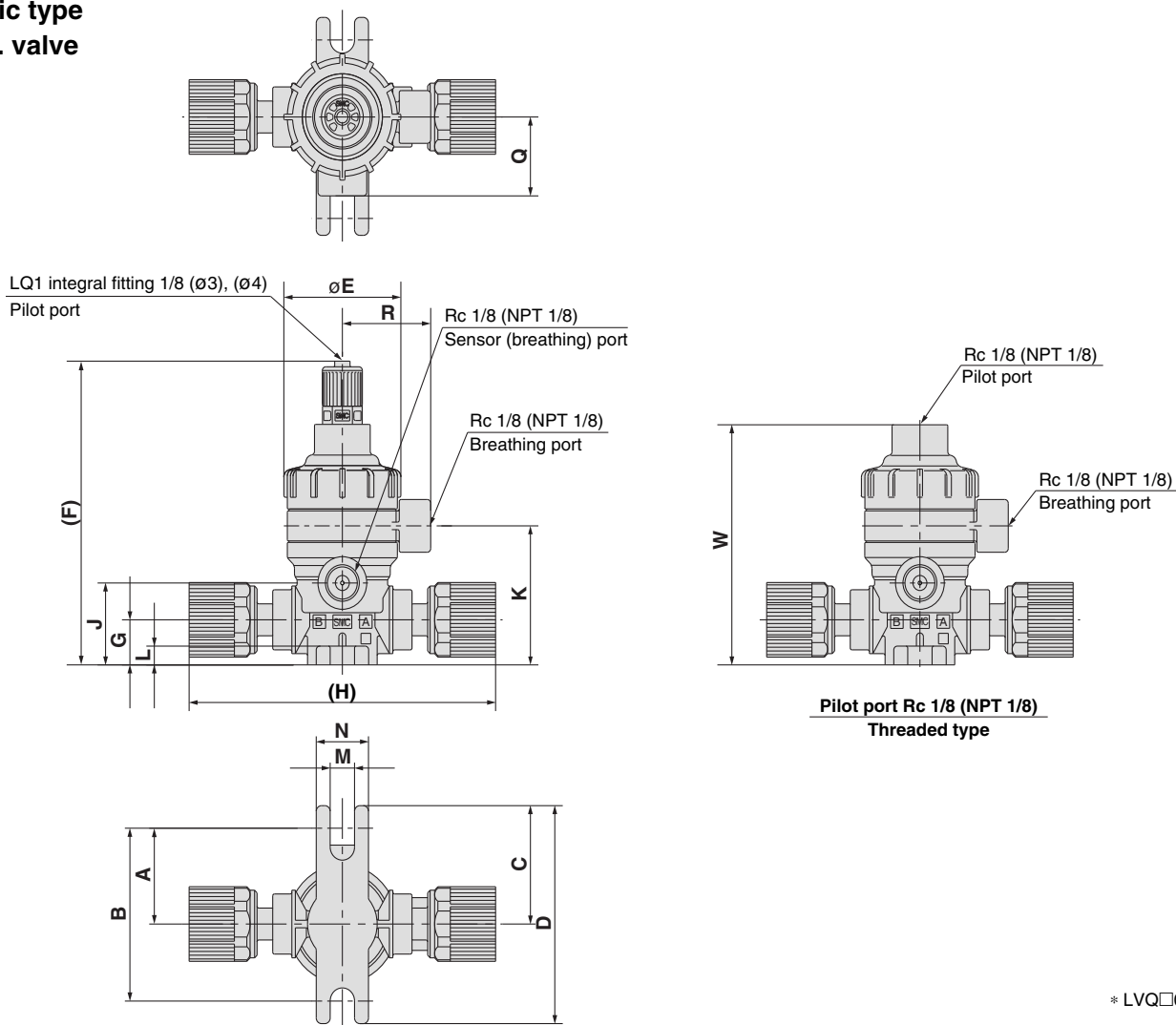

- LVC
- LVA
- LVH
- LVD
- LVQ**
- LQ1
- LVN
- TL/TIL
- LQ3

**Double acting valve**

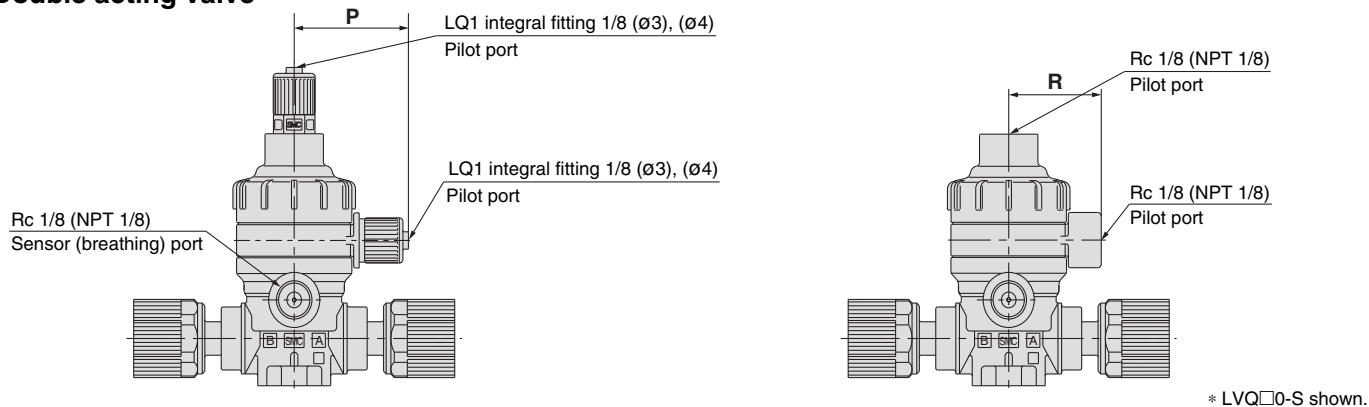

**LVQ□ $\frac{1}{2}$ S-V□□ Dimensions (N.O. valve, double acting valve)**

(mm)

Model	A	B	C	D	E	F	G	H		J	K	L	M	N	P	Q	R	W
								V□	S□									
LVQ $\frac{1}{2}$ S-V07	25.5	46	31.5	58	33.6	81	12	89	92	21.8	37	5	7	15	31.3	21	25.3	64
LVQ $\frac{3}{2}$ S-V11	28.5	57	34.5	69	45.4	99	16.5	106	112	32	50	6	7	20	37.2	25	31.2	82
LVQ $\frac{4}{2}$ S-V13	28.5	57	34.5	69	45.4	104.5	22	120	126	37.5	55.5	6	7	20	37.2	25	31.2	87.5
LVQ $\frac{5}{2}$ S-V19	42	84	48	96	75	145	25	164	168	50.2	78.2	10	7	20	50.8	38.5	45	128
LVQ $\frac{6}{2}$ S-V25*	42	84	48	96	75	154.5	32	177	—	60	88	10	7	20	50.8	38.5	45	137.5

\* LVQ60 available only as "V".



# Series LVQS

## Dimensions

With bypass

Double acting valve

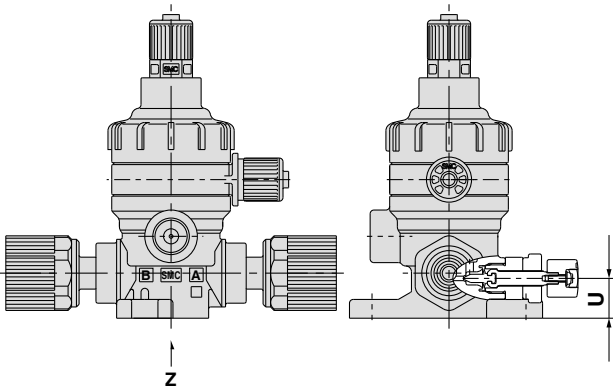
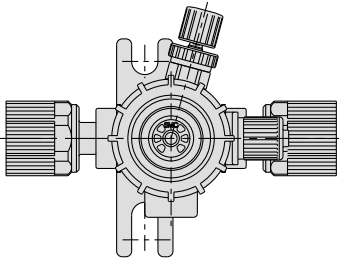

LVQ2<sup>1</sup>/<sub>2</sub>S

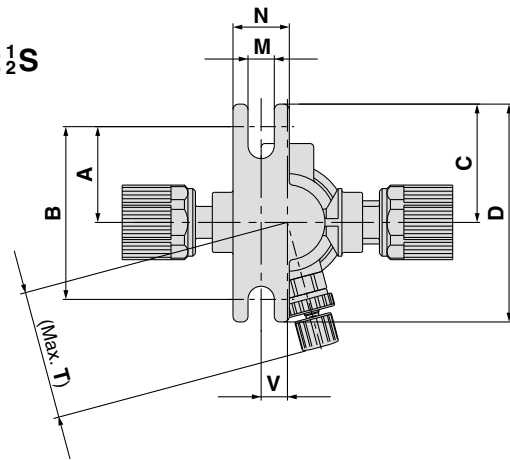

LVQ3<sup>1</sup>/<sub>2</sub>S, LVQ4<sup>1</sup>/<sub>2</sub>S  
LVQ5<sup>1</sup>/<sub>2</sub>S, LVQ6<sup>1</sup>/<sub>2</sub>S

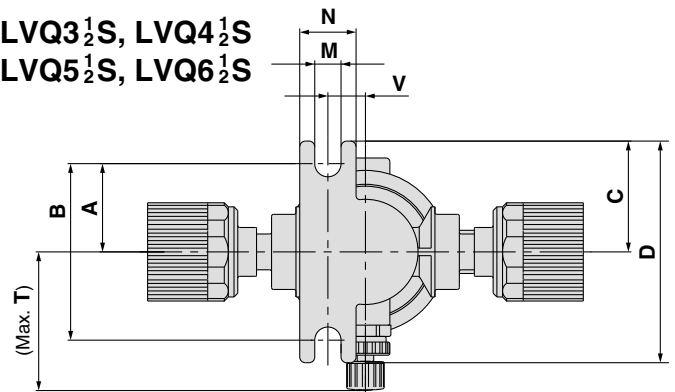

View Z

\* LVQ□0-S shown.

### Dimensions (N.O. valve, double acting valve)

(mm)

Model	A	B	C	D	M	N	T	U	V
LVQ2 <sup>1</sup> / <sub>2</sub> S-V <sup>07</sup> -2	25.5	46	31.5	58	7	15	34.3	10.6	7
LVQ3 <sup>1</sup> / <sub>2</sub> S-V <sup>11</sup> -2	25.5	51	31.5	63	7	15	36.9	16.5	10
LVQ4 <sup>1</sup> / <sub>2</sub> S-V <sup>13</sup> -2	25.5	51	31.5	63	7	15	37.9	22	10
LVQ5 <sup>1</sup> / <sub>2</sub> S-V <sup>19</sup> -2	38	76	44	88	7	20	64	25	17
LVQ6 <sup>1</sup> / <sub>2</sub> S-V <sup>25</sup> -2*	38	76	44	88	7	20	66	32	17

\* LVQ60 available only as "V".

# Manual Type Integral Fitting Type (Hyper Fittings) Series **LVQH**

## How to Order

LVQH **2** 0 - **S** **07** - **1** -

### Body class

Symbol	Body class	Orifice dia.
2	2	ø4
3	3	ø8
4	4	ø10
5	5	ø16
6	6	ø22

### Fitting type

Symbol	Fittings	Body class
V	LQ1	2, 3, 4, 5, 6
S	LQ2	2, 3, 4, 5

### Applicable tubing size

Symbol	Connecting tubing O.D.	Body class				
		2	3	4	5	6
<b>Metric sizes</b>						
03	ø3	●				
04	ø4	●				
06	ø6	○	●			
08	ø8		●			
10	ø10		○	●		
12	ø12			○	●	
19	ø19				○	●
25	ø25					○
<b>Inch sizes</b>						
03	1/8	●				
05	3/16	●				
07	1/4	○	●			
11	3/8		○	●		
13	1/2			○	●	
19	3/4				○	●
25	1					○

○ Basic size ● With reducer

### Option

Symbol	Note
Nil	Standard
K	Buffer material FFKM
N	For ammonium hydroxide



Note) Options cannot be combined with each other.

### Handle operation

1	90 Degree turn type
4	Multi-turn type (with indicator)

### Breathing port thread type

Nil	Threaded	NPT 1/8
R	Threaded	Rc 1/8

### Port B (OUT) different dia. size

Symbol	Application
Nil	Ports A & B same size
Refer to the applicable tubing table to the left.	Different diameter tubings can be selected within the same body class.

## Variations

Type	Symbol	Model	Tubing outside dia.				
			LVQH20	LVQH30	LVQH40	LVQH50	LVQH60
90 Degree turn type		Orifice diameter	ø4	ø8	ø10	ø16	ø22
			Millimeter	6	10	12	19
Multi-turn type		Inch	1/4	3/8	1/2	3/4	1
			Symbol	○	○	○	○

LVC

LVA

LVH

LVD

**LVQ**

LQ1

LVN

TL/TIL

LQ3



## Standard Specifications

Model		LVQH20	LVQH30	LVQH40	LVQH50	LVQH60
Tubing O.D.	Metric size	6	10	12	19	25
	Inch size	1/4	3/8	1/2	3/4	1
Fitting type		LQ1 or LQ2				LQ1
Orifice diameter		ø4	ø8	ø10	ø16	ø22
Flow characteristics	Av x 10 <sup>-6</sup> m <sup>2</sup>	8.4	31.2	45.6	120	192 (228) <sup>Note)</sup>
	Cv	0.35	1.3	1.9	5	8 (9.5) <sup>Note)</sup>
Withstand pressure (MPa)		1				
Operating pressure <A→B flow>		-98 kPa to 0.5 MPa			-98 kPa to 0.4 MPa	
Back pressure (MPa)		0.3 or less			0.2 or less	
Valve leakage (cm <sup>3</sup> /min)		0 (With water pressure)				
Fluid temperature (°C)		0 to 100				
Ambient temperature (°C)		0 to 60				
Mass (kg)	LVQH□0-1	0.12	0.27	0.31	1.10	1.16
	LVQH□0-4	0.11	0.20	0.22	0.67	0.87

Note) ( ) is high flow specification.

## ⚠ Specific Product Precautions

Be sure to read before handling. Refer to front matters 42 and 43 for Safety Instructions, and pages 585 and 586 for High Purity Chemical Valve Non-Metallic Exterior Precautions.

### Piping

## ⚠ Caution

### 1. Connect tubing with special tools.

Refer to the pamphlet "High-Purity Fluoropolymer Fittings HYPER FITTING®/Series LQ1, 2 Work Procedure Instructions" (M-E05-1) for connecting tubing and special tools. (Downloadable from our web site.)

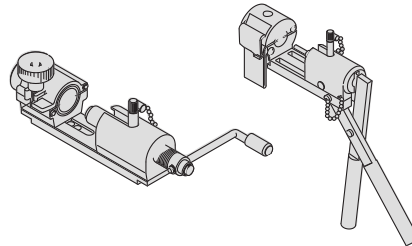

### 2. Tighten the nut to the end surface of the body. As a guide, refer to the proper tightening torques shown below.

#### Tightening torque for piping

Body class	Torque (N·m)	
	LQ1	LQ2
2	0.3 to 0.4	1.5 to 2.0
3	0.8 to 1.0	3.0 to 3.5
4	1.0 to 1.2	7.5 to 9.0
5	2.5 to 3.0	11.0 to 13.0
6	5.5 to 6.0	—

## Construction

### 90 Degree turn type

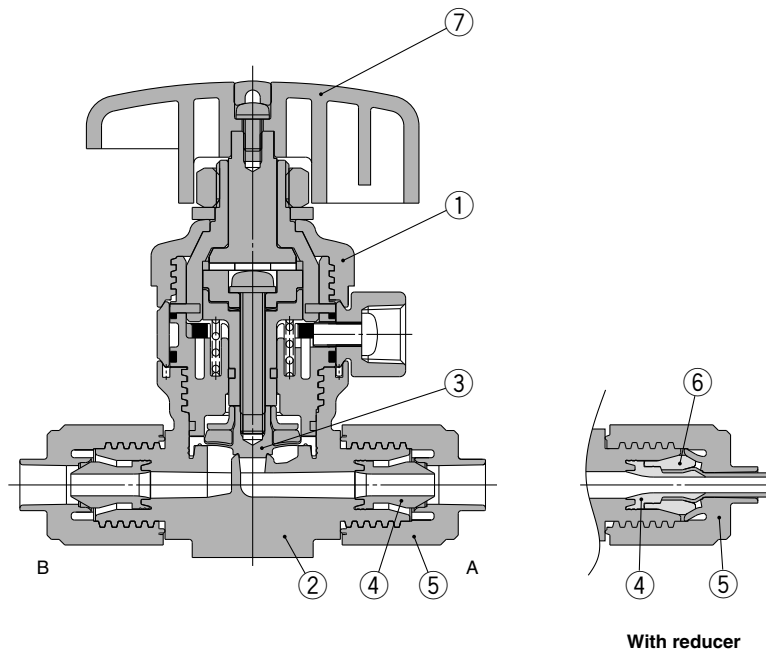

LVC

LVA

LVH

LVD

**LVQ**

LQ1

LVN

TL/TIL

LQ3

### Multi-turn type (with indicator)

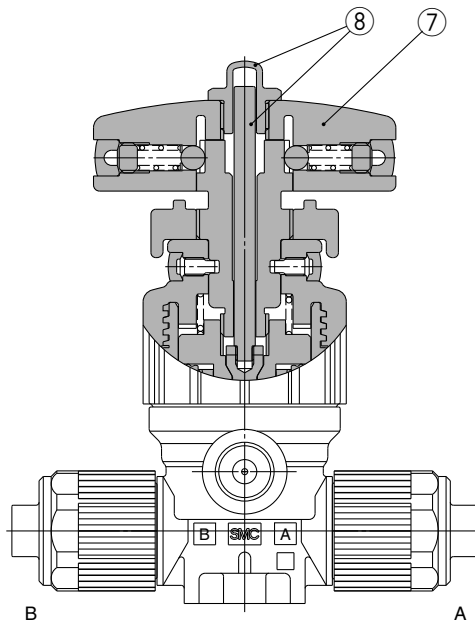

### Parts list

No.	Description	Material
1	Actuator section	PVDF
2	Body	PFA
3	Diaphragm	PTFE
4	Insert bushing	PFA
5	Nut	PFA
6	Collar	PFA
7	Handle section	PVDF
8	Indicator, cover	PP

# Series LVQH

## Dimensions

### 90 Degree turn type

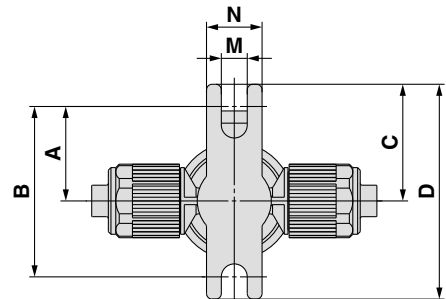
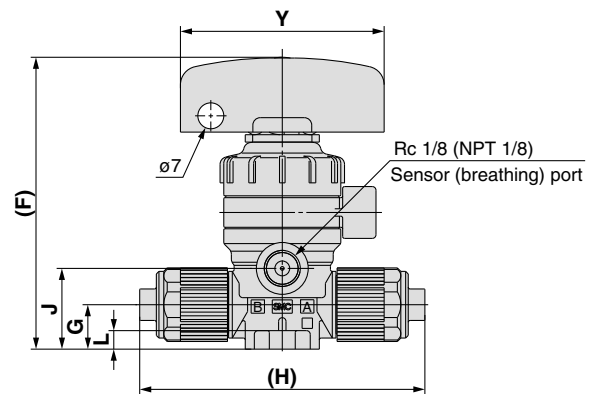
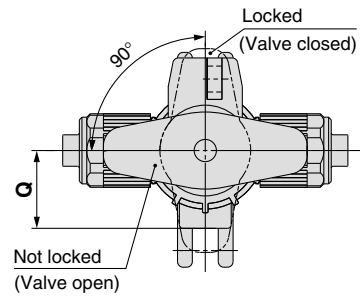

### Dimensions (mm)

Model	A	B	C	D	F	G	H	
							V□	S□
LVQH20- $\frac{V}{S}$ □-1	25.5	46	31.5	58	79	12	70	77
LVQH30- $\frac{V}{S}$ □-1	28.5	57	34.5	69	103	16.5	83	95
LVQH40- $\frac{V}{S}$ □-1	28.5	57	34.5	69	108	22	95	109
LVQH50- $\frac{V}{S}$ □-1	42	84	48	96	165	25	130	141
LVQH60-V□-1*	42	84	48	96	175	32	150	—

Model	J	K	L	M	N	Q	Y
LVQH20- $\frac{V}{S}$ □-1	21.8	37	5	7	15	21	55
LVQH30- $\frac{V}{S}$ □-1	32	50	6	7	20	25	80
LVQH40- $\frac{V}{S}$ □-1	37.5	55.5	6	7	20	25	80
LVQH50- $\frac{V}{S}$ □-1	50.2	78.2	10	7	20	38.5	110
LVQH60-V□-1*	60	88	10	7	20	38.5	110

\* LVQ60 available only as "V".  
\* LVQ□0-S shown.

### Multi-turn type (with indicator)

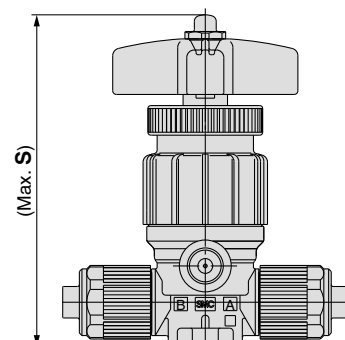
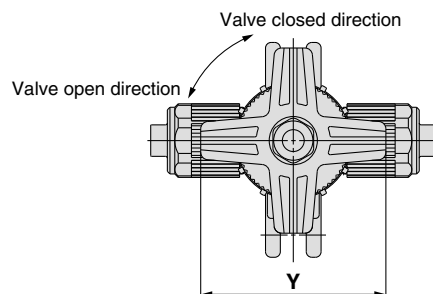

### Dimensions (mm)

Model	S	Y
LVQH20- $\frac{V}{S}$ □-4	89.6	50
LVQH30- $\frac{V}{S}$ □-4	107.2	50
LVQH40- $\frac{V}{S}$ □-4	112.7	50
LVQH50- $\frac{V}{S}$ □-4	165	71
LVQH60-V□-4*	174.5	71

\* LVQ60 available only as "V".  
\* LVQ□0-S shown.

# Manual Type Integral Fitting Type Space Saving/Space Saving Connection Series **LVQHS**

## How to Order

LVQH **2** **0** **S** - **S** **07** **1** - **1** - **1**

**Body class**

Symbol	Body class	Orifice dia.
2	2	ø4
3	3	ø8
4	4	ø10
5	5	ø16
6	6	ø22

**Body type**

<b>S</b>	Space saving connection
----------	-------------------------

**Fitting type**

Symbol	Fittings	Body class
<b>V</b>	LQ1	2, 3, 4, 5, 6
<b>S</b>	LQ2	2, 3, 4, 5

**Option**

Symbol	Note
<b>Nil</b>	Standard
<b>K</b>	Buffer material FFKM
<b>N</b>	For ammonium hydroxide

Note) Options cannot be combined with each other.

**Handle operation**

<b>1</b>	90 Degree turn type
<b>4</b>	Multi-turn type (with indicator)

**Breathing port thread type**

<b>Nil</b>	Threaded	NPT 1/8
<b>R</b>	Threaded	Rc 1/8

**Applicable fitting size**

Symbol	Connecting tubing O.D.	Body class				
		2	3	4	5	6
<b>07</b>	1/4	○				
<b>11</b>	3/8		○			
<b>13</b>	1/2			○		
<b>19</b>	3/4				○	
<b>25</b>	1					○

Note) Refer to page 540 for How to order fitting parts.  
Select the fittings of the same size as the one at the valve side.

- LVC
- LVA
- LVH
- LVD
- LVQ**
- LQ1
- LVN
- TL/TIL
- LQ3

### Variations

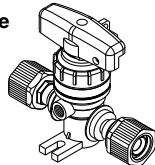
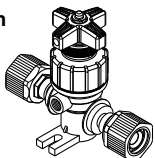
Type	Model	Orifice diameter				
		LVQH20S	LVQH30S	LVQH40S	LVQH50S	LVQH60S
		ø4	ø8	ø10	ø16	ø22
		2	3	4	5	6
<b>90 Degree turn type</b>		○	○	○	○	○
<b>Multi-turn type</b>		○	○	○	○	○

## How to Order Fittings for Space Saving

### Applicable tubing size

Size	No.	Applicable tubing size (mm)	Reducing
2	1	6 x 4	○
2	2	4 x 3	●
3	1	10 x 8	○
3	2	8 x 6	●
3	3	6 x 4	●
4	1	12 x 10	○
4	2	10 x 8	●
5	1	19 x 16	○
5	2	12 x 10	●
6	1	25 x 22	○
6	2	19 x 16	●

Size	Symbol	Applicable tubing size (inch)	Reducing
2	A	1/4" x 5/32"	○
2	B	3/16" x 1/8"	●
2	C	1/8" x 0.086"	●
3	A	3/8" x 1/4"	○
3	B	1/4" x 5/32"	●
4	A	1/2" x 3/8"	○
4	B	3/8" x 1/4"	●
5	A	3/4" x 5/8"	○
5	B	1/2" x 3/8"	●
6	A	1" x 7/8"	○
6	B	3/4" x 5/8"	●

○ Basic size ● With reducer

🔍 Note 1) Select a fitting the same size as the valve fitting.

LQ1 E 61 - S  
LQ2 E 21 - S

• One nut (including insert bushing) of the nuts is not attached.

### Type of fitting

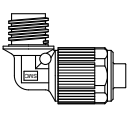
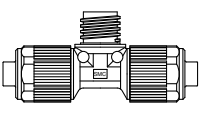
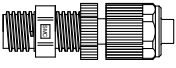
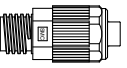
E	T
Union elbow 	Union tee 
P	U
Panel mount union 	Union 

### Applicable tubing size

Size	No.	Applicable tubing size (mm)	Reducing
2	1	6 x 4	○
2	2	4 x 3	●
3	1	10 x 8	○
3	2	8 x 6	●
3	3	6 x 4	●
4	1	12 x 10	○
4	2	10 x 8	●
5	1	19 x 16	○
5	2	12 x 10	●

Size	Symbol	Applicable tubing size (inch)	Reducing
2	A	1/4" x 5/32"	○
2	B	3/16" x 1/8"	●
2	C	1/8" x 0.086"	●
3	A	3/8" x 1/4"	○
3	B	1/4" x 5/32"	●
4	A	1/2" x 3/8"	○
4	B	3/8" x 1/4"	●
5	A	3/4" x 5/8"	○
5	B	1/2" x 3/8"	●

○ Basic size ● With reducer

🔍 Note 1) Select a fitting the same size as the valve fitting.

### Piping example

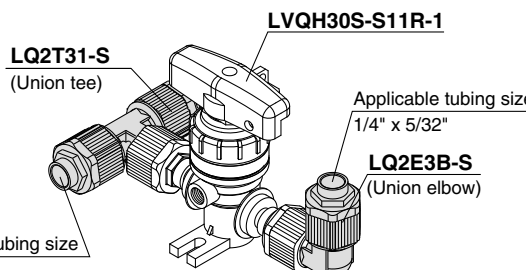

LVQH30S-S11R-1

LQ2T31-S (Union tee)

Applicable tubing size 10 x 8

LQ2E3B-S (Union elbow)

Applicable tubing size 1/4" x 5/32"

#### Example

<b>LVQH30S-S11R-1</b>	1
<b>LQ2T31-S</b> (Union tee)	1
<b>LQ2E3B-S</b> (Union elbow)	1

Note) For shipment, the valve and fittings are individually packaged and dispatched together in 1 box.



## Standard Specifications



Model		LVQH20S	LVQH30S	LVQH40S	LVQH50S	LVQH60S
Connection fitting size		2	3	4	5	6
Fitting type		LQ1 or LQ2				LQ1
Orifice diameter		ø4	ø8	ø10	ø16	ø22
Flow characteristics	Av x 10 <sup>-6</sup> m <sup>2</sup>	8.4	31.2	45.6	120	192 (228) <sup>Note)</sup>
	Cv	0.35	1.3	1.9	5	8 (9.5) <sup>Note)</sup>
Withstand pressure (MPa)		1				
Operating pressure <A→B flow>		-98 kPa to 0.5 MPa			-98 kPa to 0.4 MPa	
Back pressure (MPa)		0.3 or less			0.2 or less	
Valve leakage (cm <sup>3</sup> /min)		0 (With water pressure)				
Fluid temperature (°C)		0 to 100				
Ambient temperature (°C)		0 to 60				
Mass (kg)	LVQH□0S-1	0.14	0.30	0.33	1.14	1.18
	LVQH□S0-4	0.13	0.23	0.24	0.71	0.89

Note) ( ) is high flow specification.

## ⚠ Specific Product Precautions

Be sure to read before handling. Refer to front matters 42 and 43 for Safety Instructions, and pages 585 and 586 for High Purity Chemical Valve Non-Metallic Exterior Precautions.

### Piping

## ⚠ Caution

1. Take extra care with the insert bushing when connecting the fittings.
2. Tighten the nut to the end surface of the body. As a guide, refer to the proper tightening torques shown below.

#### Tightening torque for piping

Body class	Torque (N·m)	
	LQ1	LQ2
2	0.3 to 0.4	1.5 to 2.0
3	0.8 to 1.0	3.0 to 3.5
4	1.0 to 1.2	7.5 to 9.0
5	2.5 to 3.0	11.0 to 13.0
6	5.5 to 6.0	—

LVC

LVA

LVH

LVD

LVQ

LQ1

LVN

TL/TIL

LQ3

# Series LVQHS

## Construction

### 90 Degree turn type

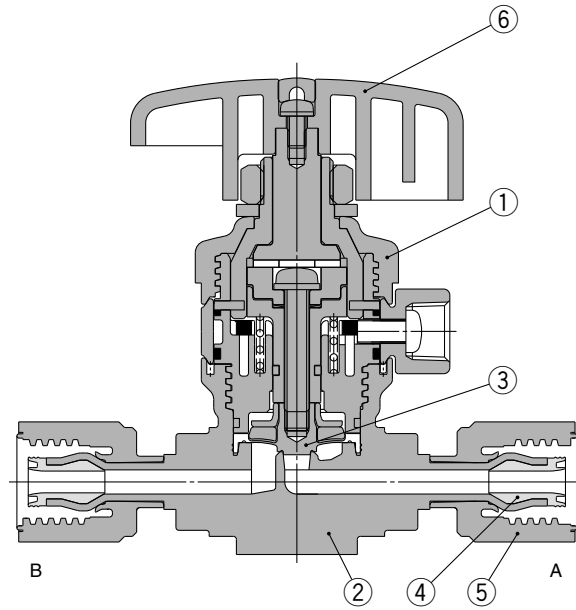

### Multi-turn type (with indicator)

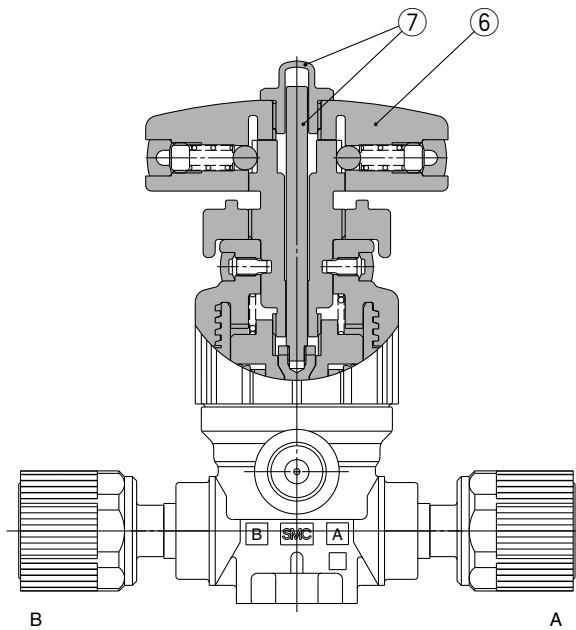

### Parts list

No.	Description	Material
1	Actuator section	PVDF
2	Body	PFA
3	Diaphragm	PTFE
4	Insert bushing	PFA
5	Nut	PFA
6	Handle section	PVDF
7	Indicator, cover	PP

## Dimensions

### 90 Degree turn type

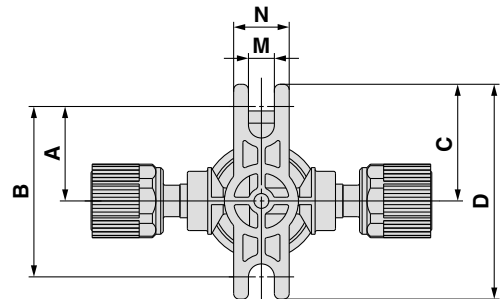
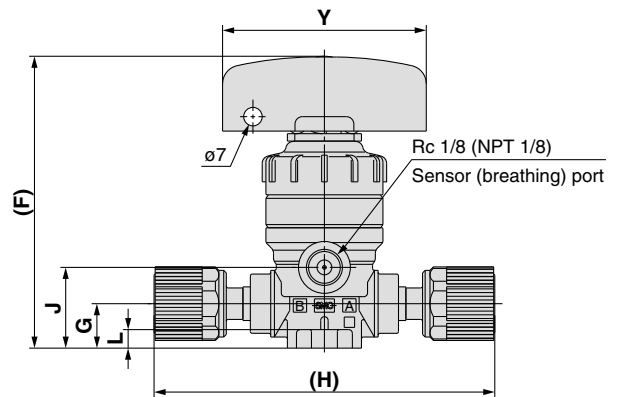
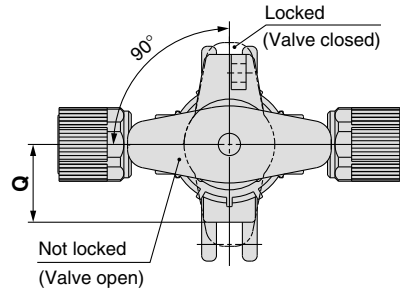

Dimensions (mm)

Model	A	B	C	D	F	G	H	
							V□	S□
LVQH20S-V□-1	25.5	46	31.5	58	79	12	89	92
LVQH30S-V□-1	28.5	57	34.5	69	103	16.5	106	112
LVQH40S-V□-1	28.5	57	34.5	69	108	22	120	126
LVQH50S-V□-1	42	84	48	96	165	25	164	168
LVQH60S-V□-1*	42	84	48	96	175	32	177	—

Model	J	L	M	N	Q	Y
LVQH20S-V□-1	21.8	5	7	15	21	55
LVQH30S-V□-1	32	6	7	20	25	80
LVQH40S-V□-1	37.5	6	7	20	25	80
LVQH50S-V□-1	50.2	10	7	20	38.5	110
LVQH60S-V□-1*	60	10	7	20	38.5	110

\* LVQ60 available only as "V".  
\* LVQ□0-S shown.

### Multi-turn type (with indicator)

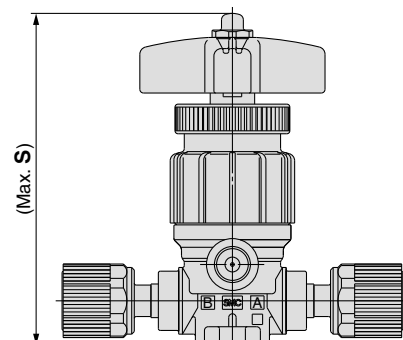
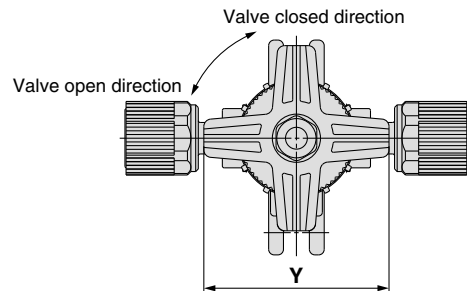

Dimensions (mm)

Model	S	Y
LVQH20S-V□-4	89.6	50
LVQH30S-V□-4	107.2	50
LVQH40S-V□-4	112.7	50
LVQH50S-V□-4	165	71
LVQH60S-V□-4*	174.5	71

\* LVQ60 available only as "V".  
\* LVQ□0-S shown.

LVC

LVA

LVH

LVD

LVQ

LQ1

LVN

TL/TIL

LQ3

# Series LVQ Fittings and Special Tools

## Fittings

### Changing tubing sizes

The tubing size can be changed within the same body class (body size) by replacing the nut and insert bushing.

Body class	Tubing O.D.													
	Metric sizes							Inch sizes						
	4	6	8	10	12	19	25	1/8	3/16	1/4	3/8	1/2	3/4	1
2	●	○	—	—	—	—	—	●	●	○	—	—	—	—
3	—	●	●	○	—	—	—	—	—	●	○	—	—	—
4	—	—	—	●	○	—	—	—	—	—	●	○	—	—
5	—	—	—	—	●	○	—	—	—	—	—	●	○	—
6	—	—	—	—	—	●	○	—	—	—	—	—	●	○

### Part composition

	Component parts		
	Nut	Insert	Collar (insert assembly)
○ Basic size	Yes	Yes	No
● Reducer type	Yes	Yes	Yes

### ⚠ Caution

#### 1. Connect tubing with special tools.

Refer to the pamphlet "High-Purity Fluoro polymer Fittings HYPER FITTING®/Series LQ1, 2 Work Procedure Instructions" (M-E05-1) for connecting tubing and special tools. (Downloadable from our web site.)

### Changing the tubing size

Example) Changing the tubing from an O.D. 1/4" to O.D. 1/8" in body class 2.

Prepare an insert bushing and nut for 1/8" O.D. tubing (LQ-2U03) and change the tubing size.

(Refer to the section on how to order fitting parts.)

Note) Tubing is sold separately.

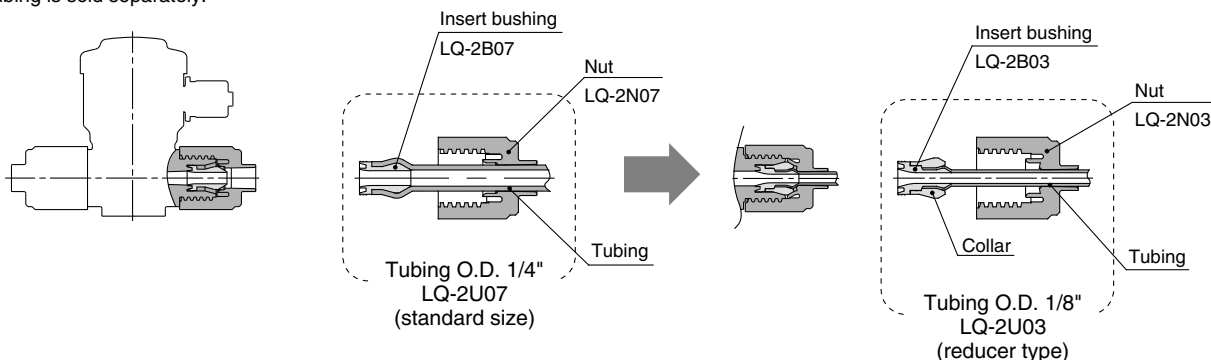

### How to order fitting parts

**LQ** 2 U 03 \* Type U is recommended when changing tubing sizes.

**Type of fitting**

Symbol	Applicable fitting
Nil	LQ2
1	LQ1

**Body class**

Symbol	Body class	Applicable fitting
2	2	LQ1
3	3	
4	4	LQ2
5	5	LQ1
6	6	

**Type of part**

Symbol	Type of part
U	Nut & insert bushing
B	Insert bushing
N	Nut

**Tubing size**

Symbol	Tubing O.D.	Body class	Applicable fitting
03	1/8" (ø3)	2	LQ1
04	ø4		
05	3/16"		
06	ø6		
07	1/4"		
06	ø6	3	LQ2
08	ø8		
10	ø10		
07	1/4"		
11	3/8"		

### For pilot port

**LQ1** 1 U 03

**Body class**

Symbol	Body class	Applicable fitting
1	1	LQ1

**Type of part**

Symbol	Type of part
U	Nut & insert bushing
B	Insert bushing
N	Nut

**Tubing size**

Symbol	Tubing O.D.	Body class
03	1/8" (ø3)	1
04	ø4	

Note) Cannot change to tubing of different diameter.

# Air Operated Type Flare Integral Fitting Type (Hyper Fittings) Series **LVQ-Z**

## How to Order

LVQ **2** **0** - **Z** **07** □ - □ - □

### Body class

Symbol	Body class	Orifice dia.
2	2	ø4
3	3	ø8
4	4	ø10
5	5	ø16
6	6	ø22

### Valve type

0	N.C.
1	N.O.
2	Double acting

Note) Refer to variations in the table below for valve type combinations.

### LQ3 integral fittings

### Applicable fitting size

Symbol	Connecting tubing O.D.	Body class					
		2	3	4	5	6	
<b>Metric sizes</b>							
03	ø3	○					
04	ø4	○					
06	ø6	○					
08	ø8		○				
10	ø10		○				
12	ø12			○			
19	ø19				○		
25	ø25					○	
<b>Inch sizes</b>							
07	1/4	○					
11	3/8		○				
13	1/2			○			
19	3/4				○		
25	1					○	

### Pilot port thread type

Nil	LQ3 integral fitting	Connection tubing O.D. 1/8" (ø3)
M	LQ3 integral fitting	Connection tubing O.D. ø4
R	Threaded	Rc 1/8
N	Threaded	NPT 1/8

### Option (1)

Nil	None	6	High back pressure with flow rate adjustment
1	With flow rate adjustment	7	High back pressure with bypass
2	With bypass	8	High back pressure with flow rate adjustment & bypass
3	With flow rate adjustment & bypass	9	High back pressure with indicator
4	With indicator	24	With indicator & bypass
5	High back pressure (0.42 MPa)		





Note) Refer to variations in the table below for valve type and option (1) combinations. Options (1) cannot be combined each other.

### Option (2)

Symbol	Applicable option										Note	
	1	2	3	4	5	6	7	8	9	24		
Nil	○	○	○	○	○	○	○	○	○	○	—	—
J	○	—	—	—	○	○	—	—	—	—	—	For high temperature
K	○	○	○	○	○	○	○	○	○	○	—	Buffer material FFKM
N	○	○	○	○	○	○	○	○	○	○	—	For ammonium hydroxide
P	—	—	—	○	○	—	—	—	—	—	—	High flow spec. LVQ6□ only

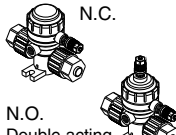
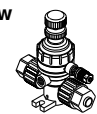
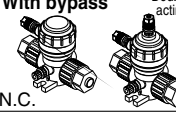
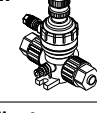
Note) Options (2) cannot be combined with each other.

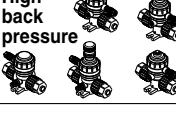
## Variations

Type	Symbol	Model	LVQ20	LVQ30	LVQ40	LVQ50	LVQ60		
			Orifice diameter		ø4	ø8	ø10	ø16	ø22
			Tubing outside dia.		6	10	12	19	25
		Valve type		1/4	3/8	1/2	3/4	1	
<b>Basic type</b> 	N.C.	N.C.	○	○	○	○	○		
	N.O.	N.O.	○	○	○	○	○		
	Double acting	Double acting	○	○	○	○	○		
<b>With flow rate adjustment</b> 	N.C.	N.C.	○	○	○	○	○		
<b>With bypass</b> 	N.C.	N.C.	○	○	○	○	○		
	Double acting	Double acting	○	○	○	○	○		
<b>With flow rate adjustment &amp; bypass</b> 	N.C.	N.C.	○	○	○	○	○		
<b>With indicator</b> 	N.C.	N.C.	○	○	○	○	○		
<b>High back pressure</b> 	N.C.	N.C.	○	○	○	○	○		
	Double acting	Double acting	○	○	○	○	○		
<b>With indicator &amp; bypass</b> 	N.C.	N.C.	○	○	○	○	○		

LVC

LVA

LVH

LVD

LVQ

LQ1

LVN

TL/TIL

LQ3



## Standard Specifications

Model		LVQ20	LVQ30	LVQ40	LVQ50	LVQ60
Tubing O.D.	Metric size	6	10	12	19	25
	Inch size	1/4	3/8	1/2	3/4	1
Orifice diameter		ø4	ø8	ø10	ø16	ø22
Flow characteristics	$Av \times 10^{-6} m^2$	8.4	31.2	45.6	120	192 (228) <sup>Note)</sup>
	Cv	0.35	1.3	1.9	5	8 (9.5) <sup>Note)</sup>
Withstand pressure (MPa)		1				
Operating pressure <A→B flow>	Standard	-98 kPa to 0.5 MPa			-98 kPa to 0.4 MPa	
	High temperature	-98 kPa to 0.3 MPa				
Back pressure (MPa)	Standard	0.3 or less			0.2 or less	
	High back pressure	0.42				
	High temperature	0.3 or less			0.2 or less	
Valve leakage (cm <sup>3</sup> /min)		0 (With water pressure)				
Pilot air pressure (MPa)		0.3 to 0.5 (High back pressure: 0.45 to 0.55)				
Pilot port size		1/8" (ø3), ø4, Rc 1/8, NPT 1/8				
Fluid temperature (°C)	Standard	0 to 100				
	High temperature	0 to 170				
Ambient temperature (°C)		0 to 60				
Mass (kg)		0.08	0.18	0.22	0.72	0.87

Note) ( ) is high flow specification.

## ⚠ Specific Product Precautions

Be sure to read before handling. Refer to front matters 42 and 43 for Safety Instructions, and pages 585 and 586 for High Purity Chemical Valve Non-Metallic Exterior Precautions.

### Piping

## ⚠ Caution

### 1. Connect tubing with special tools.

Refer to the pamphlet "High-Purity Fluoropolymer Fittings HYPER FITTING®/Flare Type Series LQ3 Fitting Procedure" (M-E06-4) for connecting tubing and special tools. (Downloadable from our web site.)

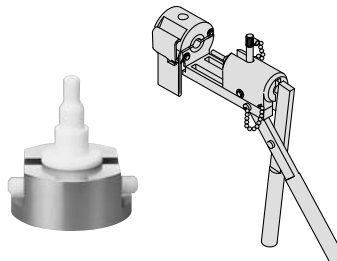

### 2. Tighten the nut to the end surface of the body. As a guide, refer to the proper tightening torques shown below.

#### Tightening torque for piping

Body class	Torque (N·m)
2	1.6 to 1.8
3	3.2 to 3.5
4	5.0 to 5.3
5	10.0 to 10.5
6	22.5 to 23.0

## Construction

Basic type

N.C. type

N.O. type

Double acting type

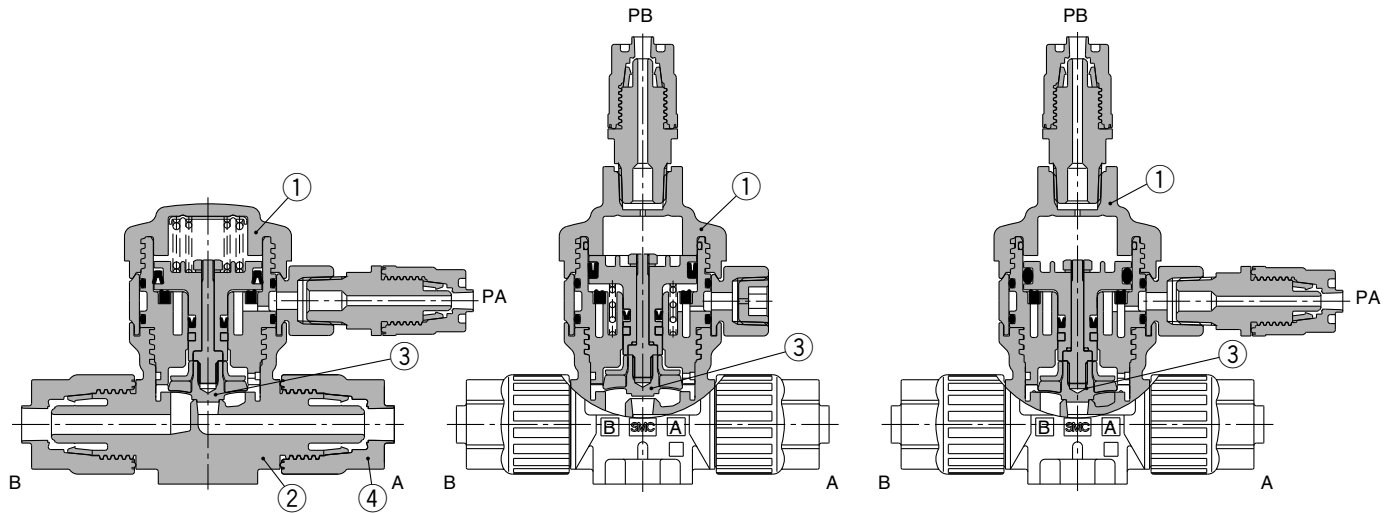

LVC

LVA

LVH

LVD

**LVQ**

LQ1

LVN

TL/TIL

LQ3

With flow rate adjustment

With bypass

With indicator

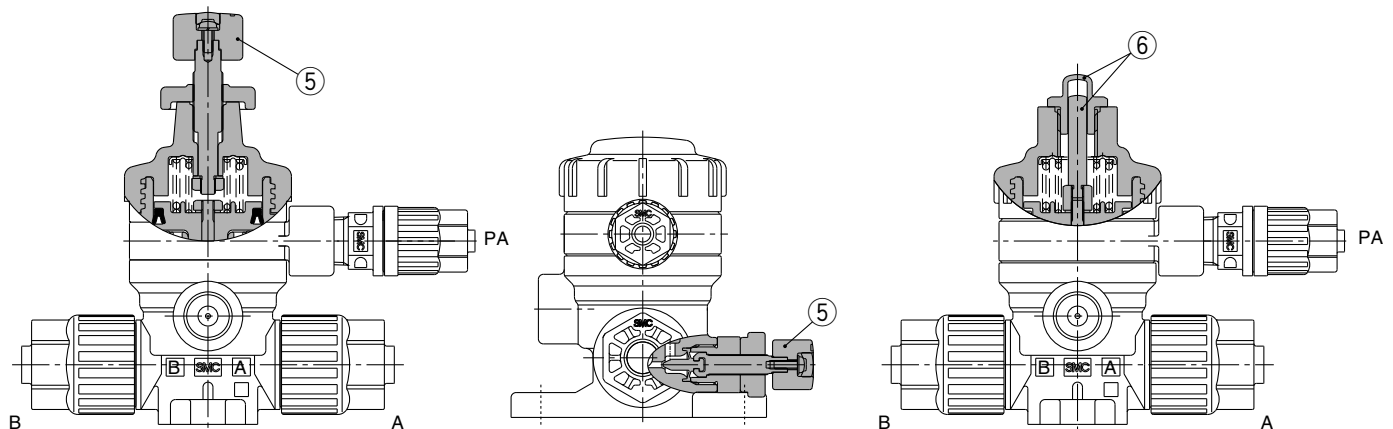

### Parts list

No.	Description	Material
1	Actuator section	PVDF
2	Body	PFA
3	Diaphragm	PTFE
4	Nut	PFA
5	Flow rate adjuster section	PVDF
6	Indicator, cover	PP



# Series LVQ-Z

## Dimensions

Basic type, High back pressure spec.

N.C. valve

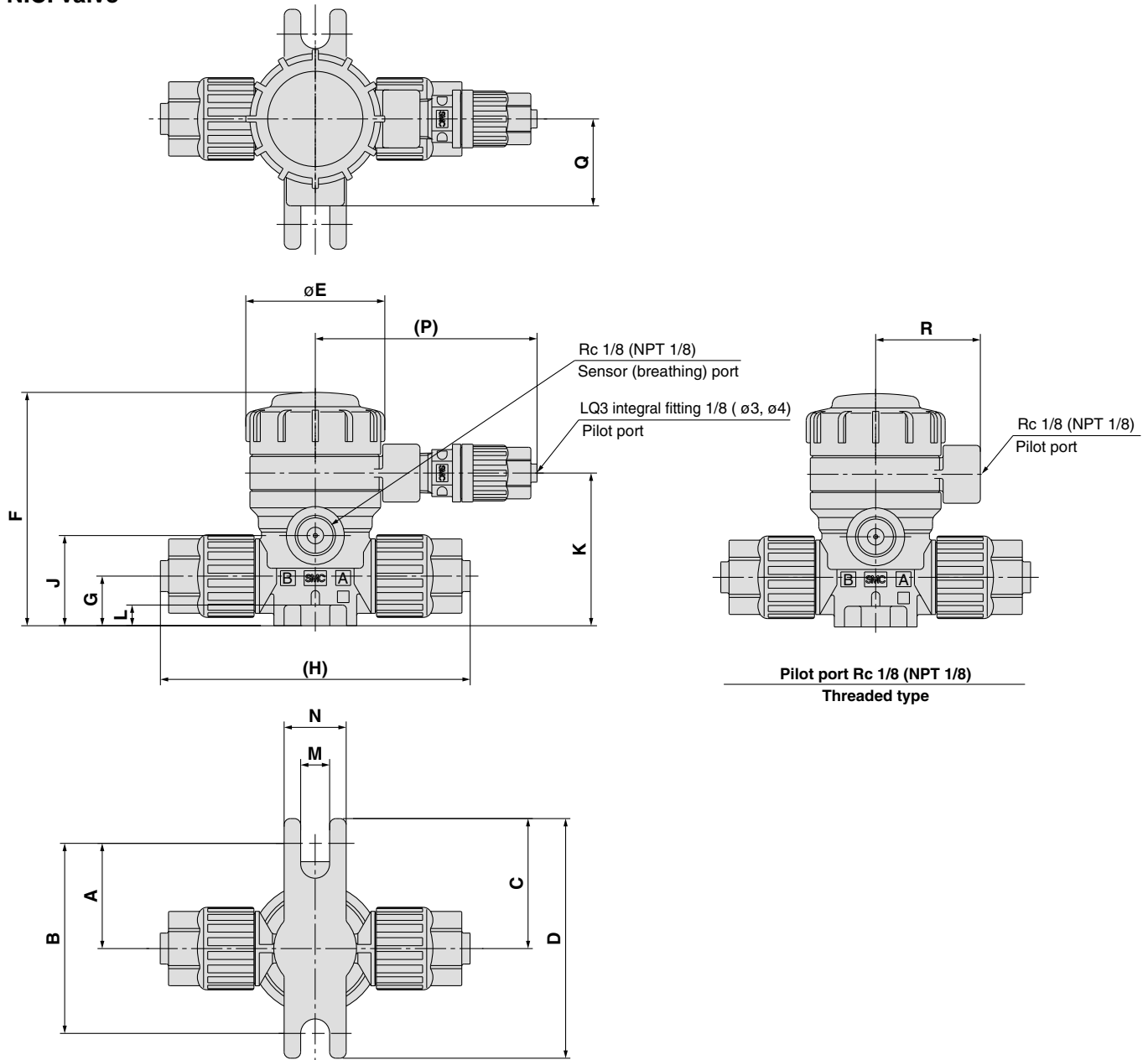

LVQ□0-Z□□ Dimensions (N.C. valve)

(mm)

Model	A	B	C	D	E	F	G	H	J	K	L	M	N	P	Q	R
LVQ20-Z□□	25.5	46	31.5	58	33.6	56.5	12	75	21.8	37	5	7	15	53.5	21	25.3
LVQ30-Z□□	28.5	57	34.5	69	45.4	77	16.5	103	32	50	6	7	20	59.5	25	31.2
LVQ40-Z□□	28.5	57	34.5	69	45.4	82.5	22	114	37.5	55.5	6	7	20	59.5	25	31.2
LVQ50-Z□□	42	84	48	96	75	127	25	150	50.2	78.2	10	7	20	73	38.5	45
LVQ60-Z□□	42	84	48	96	75	136.8	32	167	60	88	10	7	20	73	38.5	45

**With flow rate adjustment  
N.C. valve**

Dimensions (mm)	
Model	S
LVQ20-Z□□-1	83
LVQ30-Z□□-1	113.5
LVQ40-Z□□-1	119
LVQ50-Z□□-1	171.5
LVQ60-Z□□-1	182.5

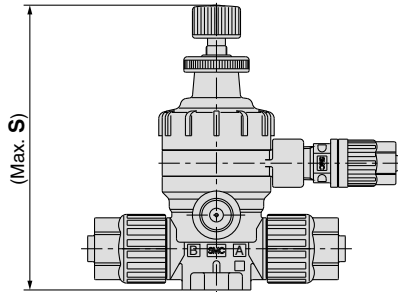

**With bypass  
N.C. valve**

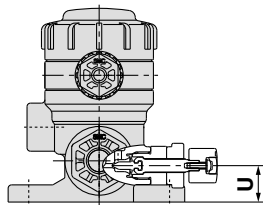
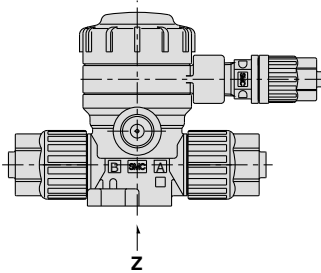
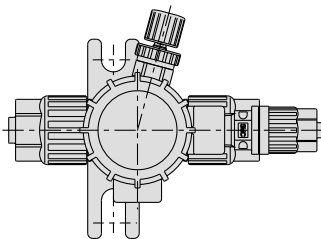

**LVQ20**

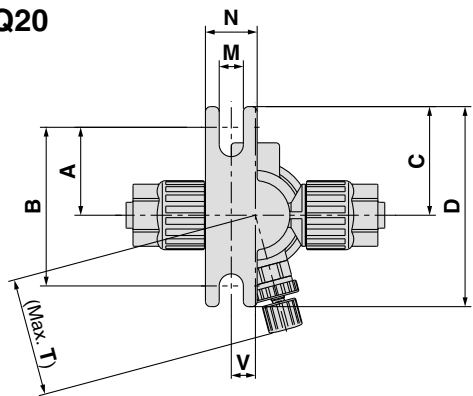

**LVQ30, LVQ40  
LVQ50, LVQ60**

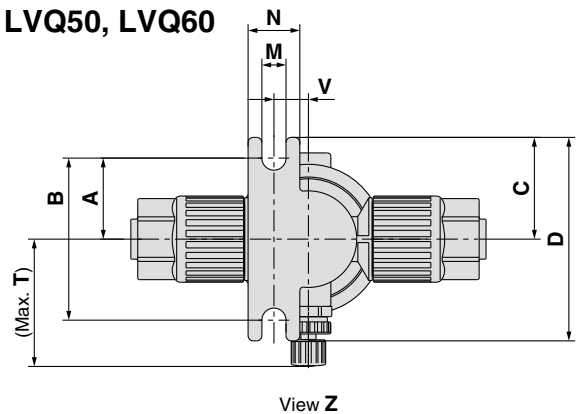

Dimensions (mm)									
Model	A	B	C	D	M	N	T	U	V
LVQ20-Z□□-2	25.5	46	31.5	58	7	15	34.3	10.6	7
LVQ30-Z□□-2	25.5	51	31.5	63	7	15	36.9	16.5	10
LVQ40-Z□□-2	25.5	51	31.5	63	7	15	37.9	22	10
LVQ50-Z□□-2	38	76	44	88	7	20	64	25	17
LVQ60-Z□□-2	38	76	44	88	7	20	66	32	17

- LVC
- LVA
- LVH
- LVD
- LVQ**
- LQ1
- LVN
- TL/TIL
- LQ3

# Series LVQ-Z

## Dimensions

With flow rate adjustment & bypass  
N.C. valve

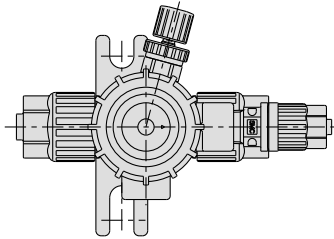

LVQ20

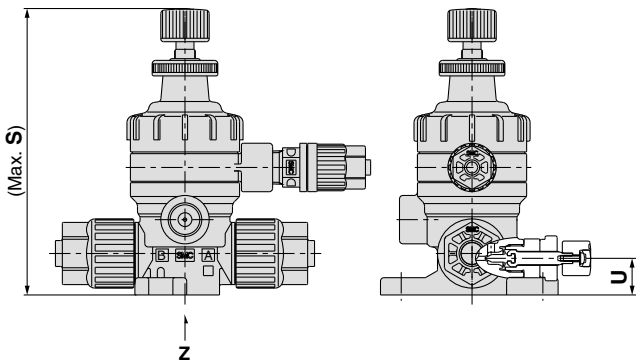
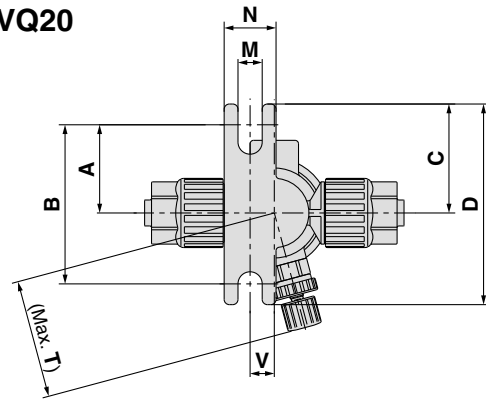

LVQ30, LVQ40  
LVQ50, LVQ60

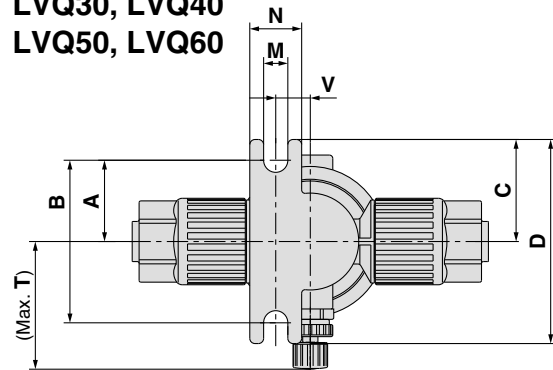

View Z

### Dimensions (mm)

Model	A	B	C	D	M	N	S	T	U	V
LVQ20-Z□□-3	25.5	46	31.5	58	7	15	83	34.3	10.6	7
LVQ30-Z□□-3	25.5	51	31.5	63	7	15	113.5	36.9	16.5	10
LVQ40-Z□□-3	25.5	51	31.5	63	7	15	119	37.9	22	10
LVQ50-Z□□-3	38	76	44	88	7	20	171.5	64	25	17
LVQ60-Z□□-3	38	76	44	88	7	20	182.5	66	32	17

With indicator  
N.C. valve

### Dimensions (mm)

Model	S
LVQ20-Z□□-4	70.5
LVQ30-Z□□-4	88.5
LVQ40-Z□□-4	94
LVQ50-Z□□-4	134.5
LVQ60-Z□□-4	144

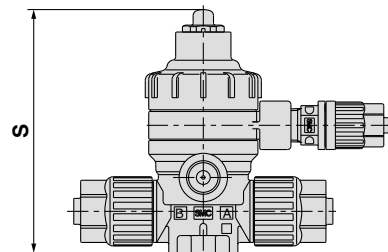

**Basic type  
N.O. valve**

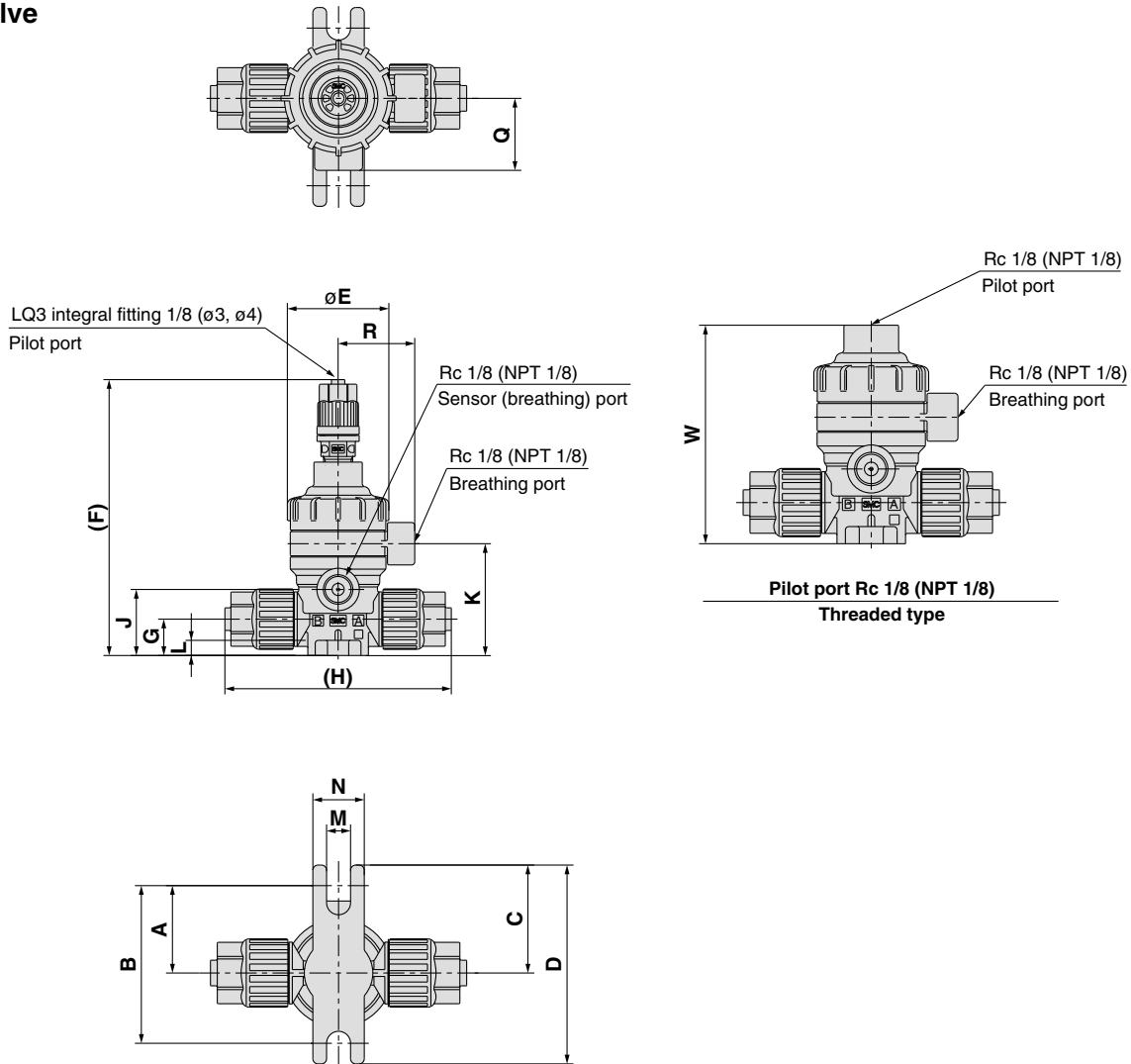

- LVC
- LVA
- LVH
- LVD
- LVQ**
- LQ1
- LVN
- TL/TIL
- LQ3

**Double acting valve**

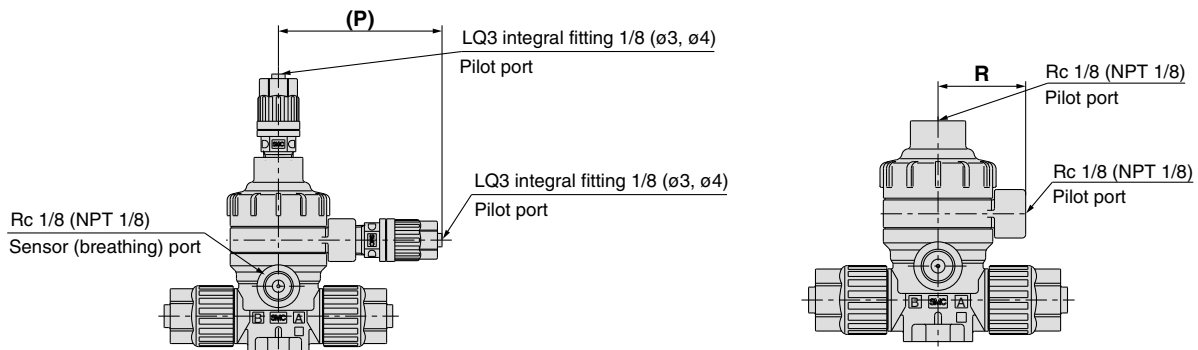

**LVQ□<sub>2</sub>-Z□□ Dimensions (N.O. valve, double acting valve)**

Model	A	B	C	D	E	F	G	H	J	K	L	M	N	P	Q	R	W
LVQ2 <sub>2</sub> -Z□□	25.5	46	31.5	58	33.6	89.5	12	75	21.8	37	5	7	15	53.5	21	25.3	64
LVQ3 <sub>2</sub> -Z□□	28.5	57	34.5	69	45.4	107.5	16.5	103	32	50	6	7	20	59.5	25	31.2	82
LVQ4 <sub>2</sub> -Z□□	28.5	57	34.5	69	45.4	113	22	114	37.5	55.5	6	7	20	59.5	25	31.2	87.5
LVQ5 <sub>2</sub> -Z□□	42	84	48	96	75	153.2	25	150	50.2	78.2	10	7	20	73	38.5	45	128
LVQ6 <sub>2</sub> -Z□□	42	84	48	96	75	163	32	167	60	88	10	7	20	73	38.5	45	137.5

# Series LVQ-Z

## Dimensions

With bypass

Double acting valve

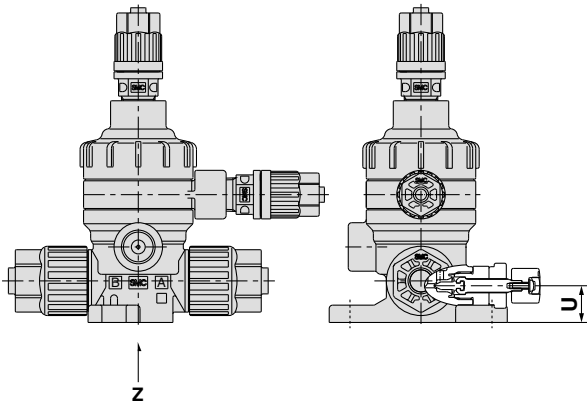
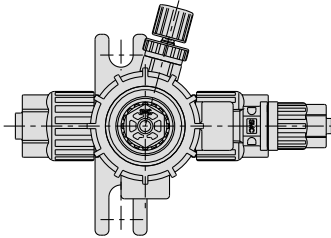

LVQ2<sup>1</sup><sub>2</sub>

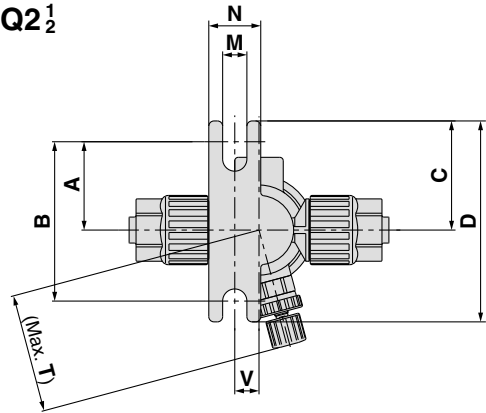

LVQ3<sup>1</sup><sub>2</sub>, LVQ4<sup>1</sup><sub>2</sub>  
LVQ5<sup>1</sup><sub>2</sub>, LVQ6<sup>1</sup><sub>2</sub>

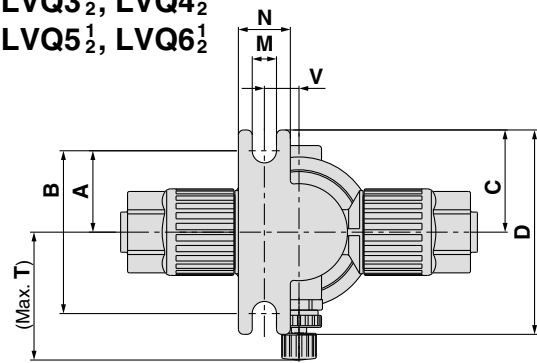

View Z

### Dimensions (N.O valve, double acting valve)

(mm)

Model	A	B	C	D	M	N	T	U	V
LVQ2 <sup>1</sup> <sub>2</sub> -Z□□-2	25.5	46	31.5	58	7	15	34.3	10.6	7
LVQ3 <sup>1</sup> <sub>2</sub> -Z□□-2	25.5	51	31.5	63	7	15	36.9	16.5	10
LVQ4 <sup>1</sup> <sub>2</sub> -Z□□-2	25.5	51	31.5	63	7	15	37.9	22	10
LVQ5 <sup>1</sup> <sub>2</sub> -Z□□-2	38	76	44	88	7	20	64	25	17
LVQ6 <sup>1</sup> <sub>2</sub> -Z□□-2	38	76	44	88	7	20	66	32	17

# Air Operated Type Flare Integral Fitting Type Space Saving/Space Saving Connection Series **LVQS-Z**

## How to Order

LVQ 2 0 S - Z 07 - - -

### Body class

Symbol	Body class	Orifice dia.
2	2	ø4
3	3	ø8
4	4	ø10
5	5	ø16
6	6	ø22

### Valve type

0	N.C.
1	N.O.
2	Double acting

Note) Refer to variations in the table below for valve type combinations.

### Body type

S	Space saving connection
---	-------------------------

### LQ3 integral fitting

### Applicable fitting size

Symbol	Connecting tubing O.D.	Body class				
		2	3	4	5	6
07	1/4	○				
11	3/8		○			
13	1/2			○		
19	3/4				○	
25	1					○

Note) Refer to page 554 for How to order fitting parts. Select the fittings of the same size as the one at the valve side.

### Option (2)

Symbol	Applicable option									Note	
	1	2	3	4	5	6	7	8	9		24
Nil	○	○	○	○	○	○	○	○	○	○	—
J	○	—	—	—	—	—	—	—	—	—	For high temperature
K	○	○	○	○	○	○	○	○	○	○	Buffer material FFKM
N	○	○	○	○	○	○	○	○	○	○	For ammonium hydroxide
P	—	—	—	○	○	—	—	—	—	—	High flow spec. LVQ6□ only

### Pilot port thread type

Nil	LQ3 integral fitting	Connection tubing O.D. 1/8" (ø3)
M	LQ3 integral fitting	Connection tubing O.D. ø4
R	Threaded	Rc 1/8
N	Threaded	NPT 1/8

### Option (1)

Nil	None	6	High back pressure with flow rate adjustment
1	With flow rate adjustment	7	High back pressure with bypass
2	With bypass	8	High back pressure with flow rate adjustment & bypass
3	With flow rate adjustment & bypass	9	High back pressure with indicator
4	With indicator	24	With indicator & bypass
5	High back pressure (0.42 MPa)		

Note) Options (2) cannot be combined with each other.

Note) Refer to variations in the table below for valve type and option (1) combinations. Options (1) can not be combined with each other.

### Variations

Type	Symbol	Model	Orifice diameter				
			LVQ20S	LVQ30S	LVQ40S	LVQ50S	LVQ60S
			ø4	ø8	ø10	ø16	ø22
Basic type							
N.C.							
N.O.							
Double acting							
With flow rate adjustment							
With bypass							
With flow rate adjustment & bypass							
With indicator							
High back pressure							
With indicator & bypass							

LVC

LVA

LVH

LVD

LVQ

LQ1

LVN

TL/TIL

LQ3

## How to Order Fittings for Space Saving

**LQ3 E 6A - S**

• One nut of the nuts is not attached.

Type of fitting

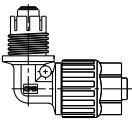
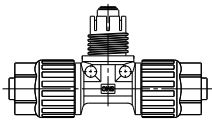
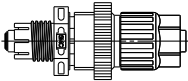
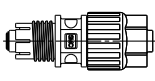
E	T
Union elbow 	Union tee 
P	U
Panel mount union 	Union 

• Applicable tubing size

Size	Symbol	Applicable tubing size (inch)
2	A	1/4" x 5/32"
3	A	3/8" x 1/4"
4	A	1/2" x 3/8"
5	A	3/4" x 5/8"
6	A	1" x 7/8"



Note 1) Select a fitting the same size as the valve fitting.

### Piping example

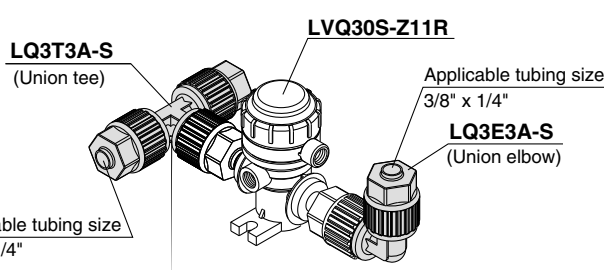

Applicable tubing size  
3/8" x 1/4"

**Example**

<b>LVQ30S-Z11R</b>	1
<b>LQ3T3A-S</b> (Union tee)	1
<b>LQ3E3A-S</b> (Union elbow)	1

Note) For shipment, the valve and fittings are individually packaged and dispatched together in 1 box.

## Standard Specifications



Model		LVQ20S	LVQ30S	LVQ40S	LVQ50S	LVQ60S
Connection fitting size		2	3	4	5	6
Orifice diameter		ø4	ø8	ø10	ø16	ø22
Flow characteristics	Av x 10 <sup>-6</sup> m <sup>2</sup>	8.4	31.2	45.6	120	192 (228) <sup>Note)</sup>
	Cv	0.35	1.3	1.9	5	8 (9.5) <sup>Note)</sup>
Withstand pressure (MPa)		1				
Operating pressure <A→B flow>	Standard	-98 kPa to 0.5 MPa			-98 kPa to 0.4 MPa	
	High temperature	-98 kPa to 0.3 MPa				
Back pressure (MPa)	Standard	0.3 or less			0.2 or less	
	High back pressure	0.42 or less				
	High temperature	0.3 or less			0.2 or less	
Valve leakage (cm <sup>3</sup> /min)		0 ( With water pressure)				
Pilot air pressure (MPa)		0.3 to 0.5 (High back pressure: 0.45 to 0.55)				
Pilot port size		1/8" (ø3), ø4, Rc 1/8, NPT 1/8				
Fluid temperature (°C)	Standard	0 to 100				
	High temperature	0 to 170				
Ambient temperature (°C)		0 to 60				
Mass (kg)		0.085	0.175	0.223	0.725	0.835

Note) ( ) is high flow specification.

LVC

LVA

LVH

LVD

**LVQ**

LQ1

LVN

TL/TIL

LQ3

### ⚠ Specific Product Precautions

Be sure to read before handling. Refer to front matters 42 and 43 for Safety Instructions, and pages 585 and 586 for High Purity Chemical Valve Non-Metallic Exterior Precautions.

#### Piping

### ⚠ Caution

1. Tighten the nut to the end surface of the body. As a guide, refer to the proper tightening torques shown below.

#### Tightening torque for piping

Body class	Torque (N·m)
<b>2</b>	1.6 to 1.8
<b>3</b>	3.2 to 3.5
<b>4</b>	5.0 to 5.3
<b>5</b>	10.0 to 10.5
<b>6</b>	22.5 to 23.0



# Series LVQS-Z

## Construction

Basic type

N.C. type

N.O. type

Double acting type

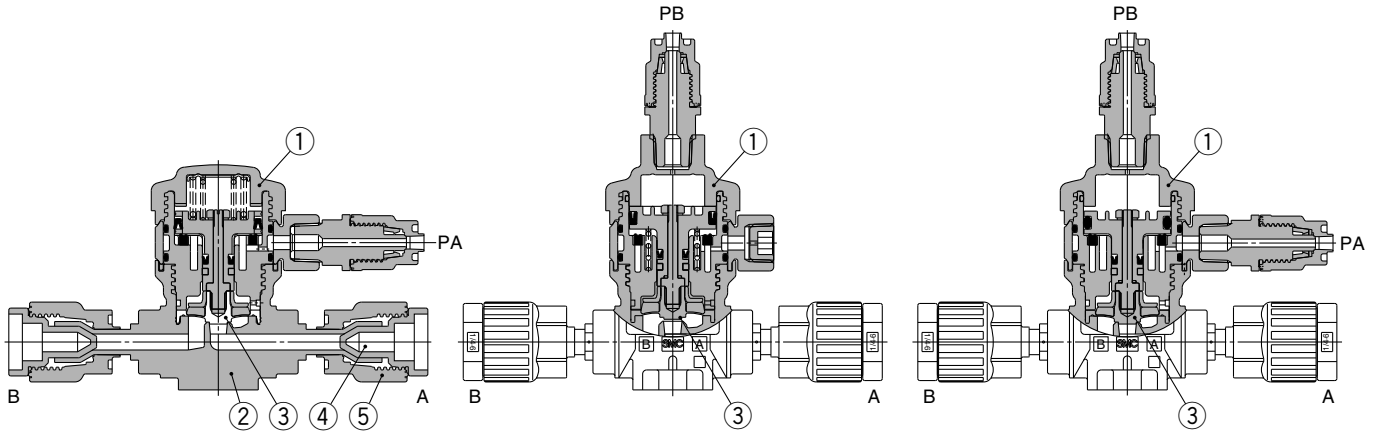

With flow rate adjustment

With bypass

With indicator

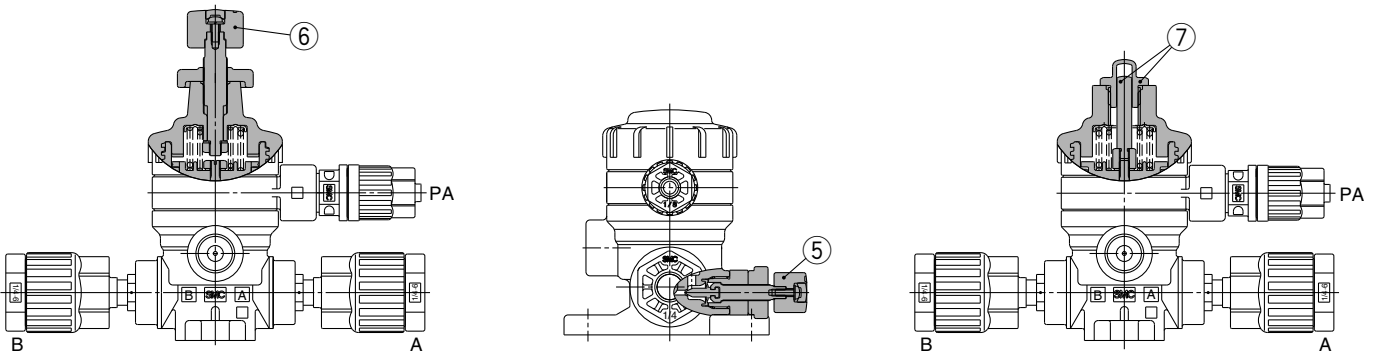

### Parts list

No.	Description	Material
1	Actuator section	PVDF
2	Body	PFA
3	Diaphragm	PTFE
4	Plug	PFA
5	Nut	PFA
6	Flow rate adjuster section	PVDF
7	Indicator, cover	PP

## Dimensions

Basic type, High back pressure spec.

N.C. valve

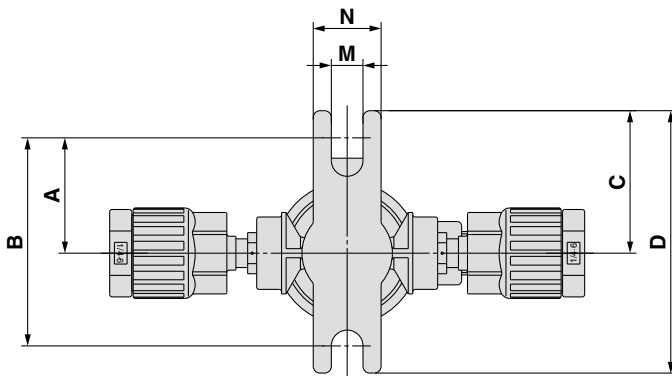
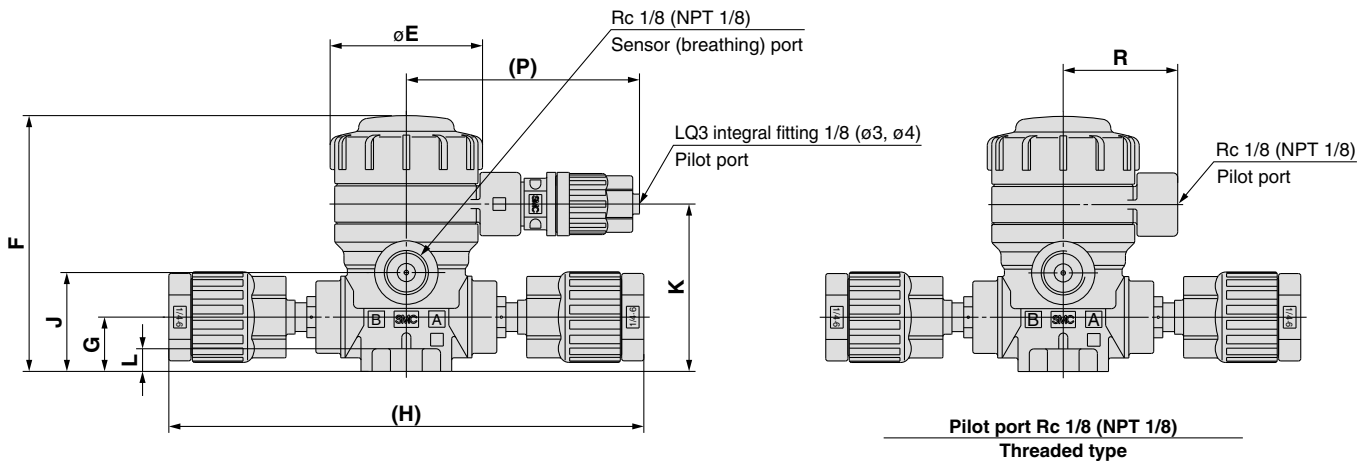
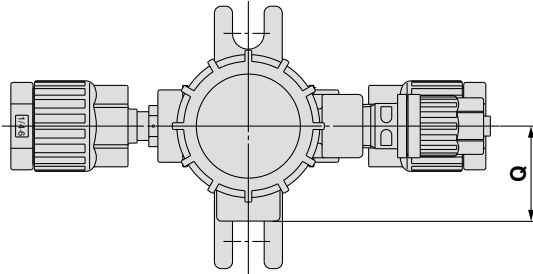

LVQ□0S-Z□ Dimensions (N.C. valve)

(mm)

Model	A	B	C	D	E	F	G	H	J	K	L	M	N	P	Q	R
LVQ20S-Z□	25.5	46	31.5	58	33.6	56.5	12	105	21.8	37	5	7	15	53.5	21	25.3
LVQ30S-Z□	28.5	57	34.5	69	45.4	77	16.5	137	32	50	6	7	20	59.5	25	31.2
LVQ40S-Z□	28.5	57	34.5	69	45.4	82.5	22	151	37.5	55.5	6	7	20	59.5	25	31.2
LVQ50S-Z□	42	84	48	96	75	127	25	202	50.2	78.2	10	7	20	73	38.5	45
LVQ60S-Z□	42	84	48	96	75	136.8	32	236	60	88	10	7	20	73	38.5	45

LVC

LVA

LVH

LVD

**LVQ**

LQ1

LVN

TL/TIL

LQ3

# Series LVQS-Z

## Dimensions

With flow rate adjustment, High back pressure spec. with flow rate adjustment  
N.C. valve

Dimensions (mm)	
Model	S
LVQ20S-Z□-1	83
LVQ30S-Z□-1	113.5
LVQ40S-Z□-1	119
LVQ50S-Z□-1	171.5
LVQ60S-Z□-1	182.5

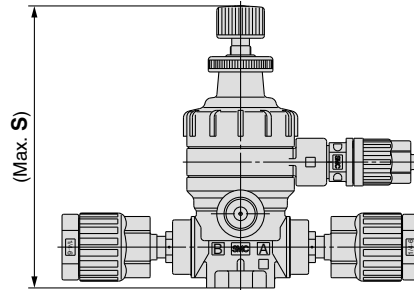

With bypass, High back pressure spec. with bypass  
N.C. valve

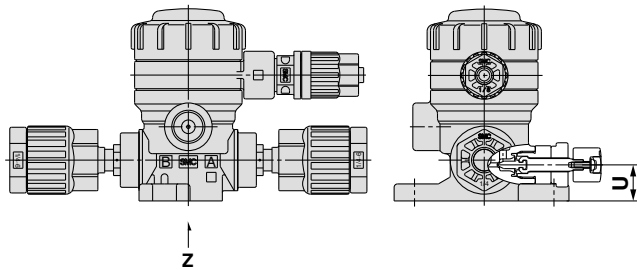
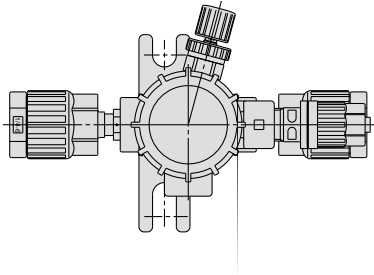

LVQ20S

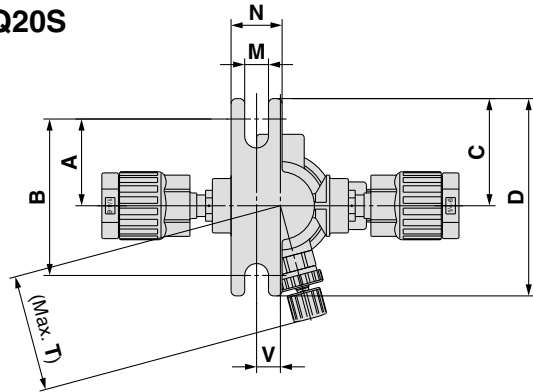

LVQ30S, LVQ40S  
LVQ50S, LVQ60S

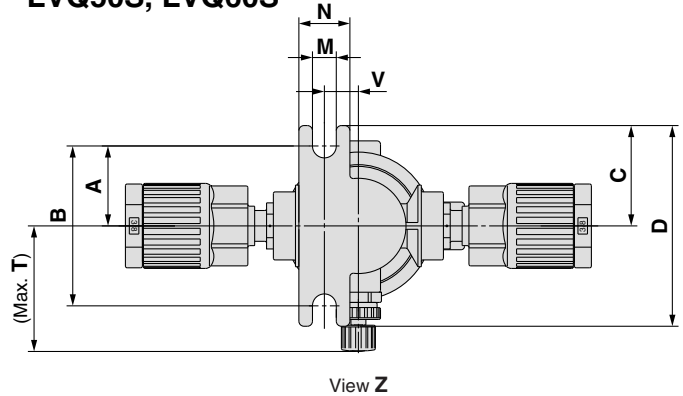

Dimensions (mm)									
Model	A	B	C	D	M	N	T	U	V
LVQ20S-Z□-2	25.5	46	31.5	58	7	15	34.3	10.6	7
LVQ30S-Z□-2	25.5	51	31.5	63	7	15	36.9	16.5	10
LVQ40S-Z□-2	25.5	51	31.5	63	7	15	37.9	22	10
LVQ50S-Z□-2	38	76	44	88	7	20	64	25	17
LVQ60S-Z□-2	38	76	44	88	7	20	66	32	17

With flow rate adjustment & bypass  
High back pressure spec.  
with flow rate adjustment & bypass  
N.C. valve

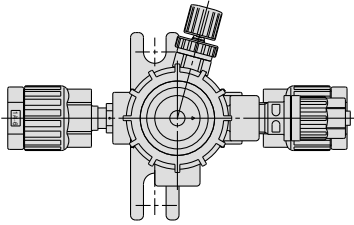

LVQ20S

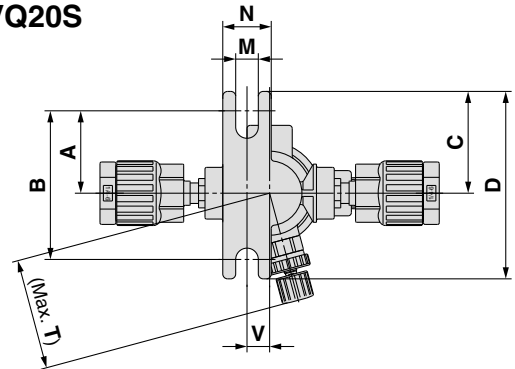

LVC

LVA

LVH

LVD

**LVQ**

LQ1

LVN

TL/TIL

LQ3

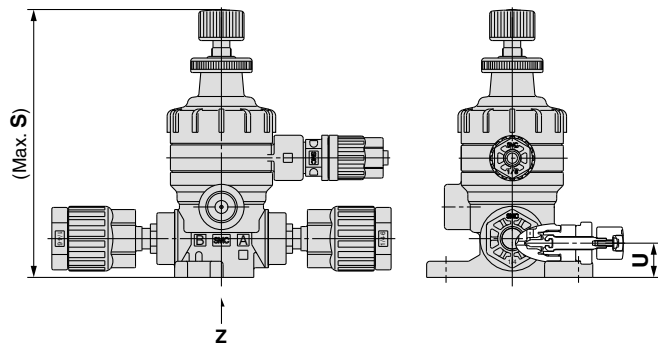

LVQ30S, LVQ40S  
LVQ50S, LVQ60S

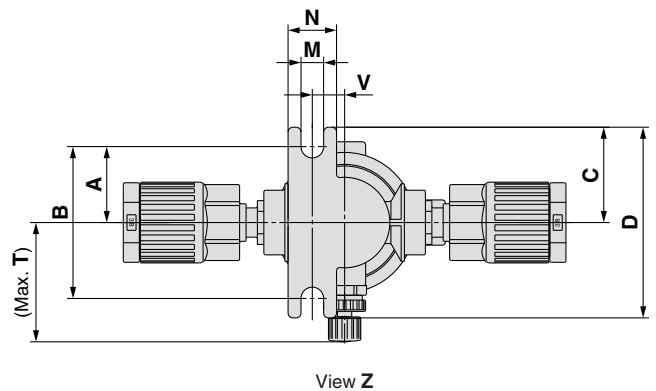

Dimensions		(mm)								
Model	A	B	C	D	M	N	S	T	U	V
LVQ20S-Z□-3	25.5	46	31.5	58	7	15	83	34.3	10.6	7
LVQ30S-Z□-3	25.5	51	31.5	63	7	15	113.5	36.9	16.5	10
LVQ40S-Z□-3	25.5	51	31.5	63	7	15	119	37.9	22	10
LVQ50S-Z□-3	38	76	44	88	7	20	171.5	64	25	17
LVQ60S-Z□-3	38	76	44	88	7	20	182.5	66	32	17

With indicator, High back pressure spec. with indicator  
N.C. valve

Dimensions		(mm)
Model	S	
LVQ20S-Z□-4	70.5	
LVQ30S-Z□-4	88.5	
LVQ40S-Z□-4	94	
LVQ50S-Z□-4	134.5	
LVQ60S-Z□-4	144	

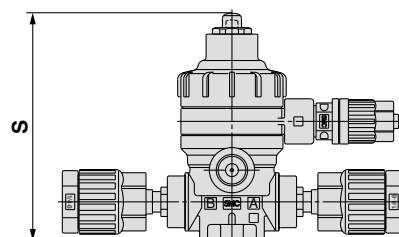

# Series LVQS-Z

## Dimensions

### Basic type N.O. valve

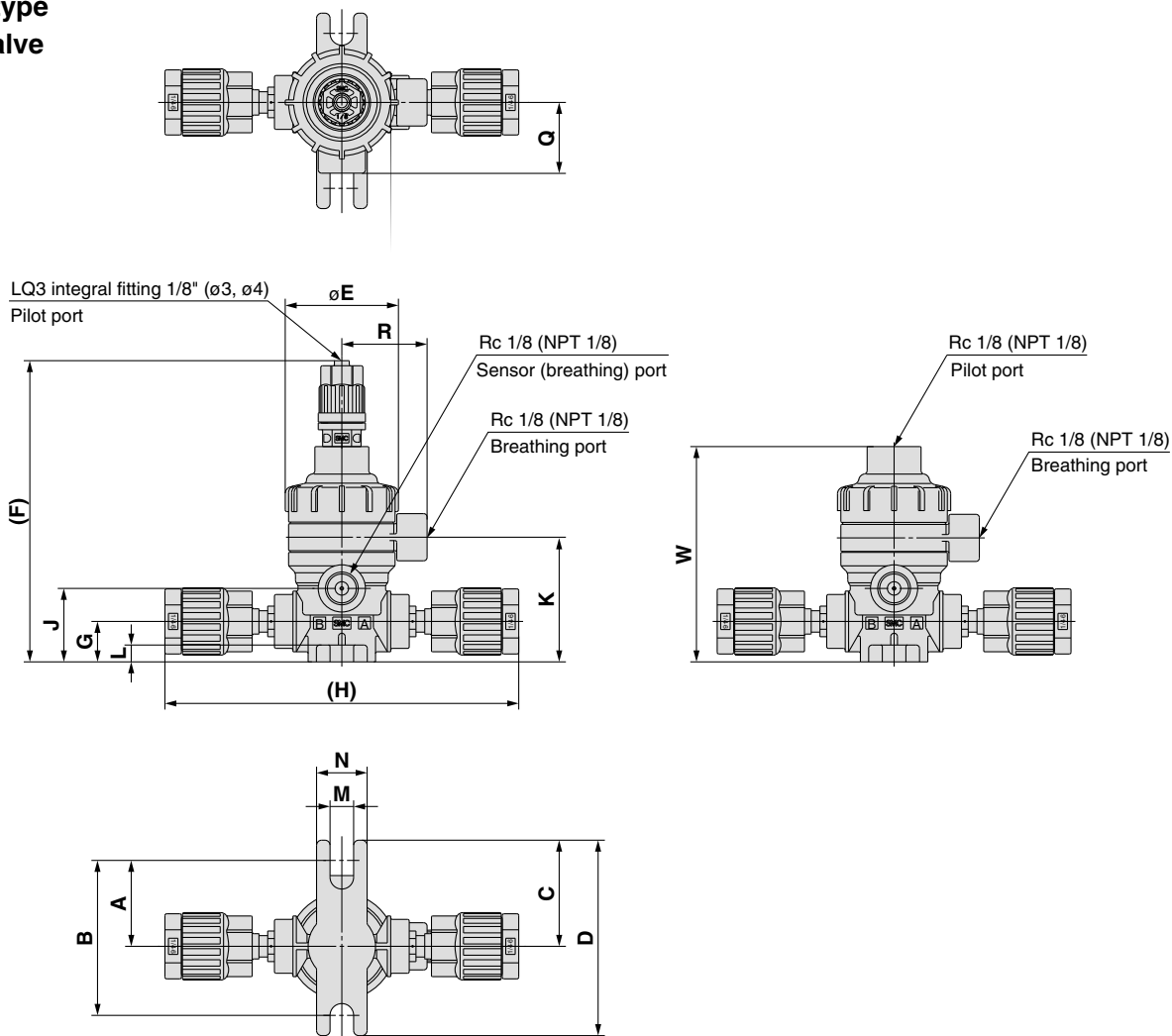

### Double acting valve

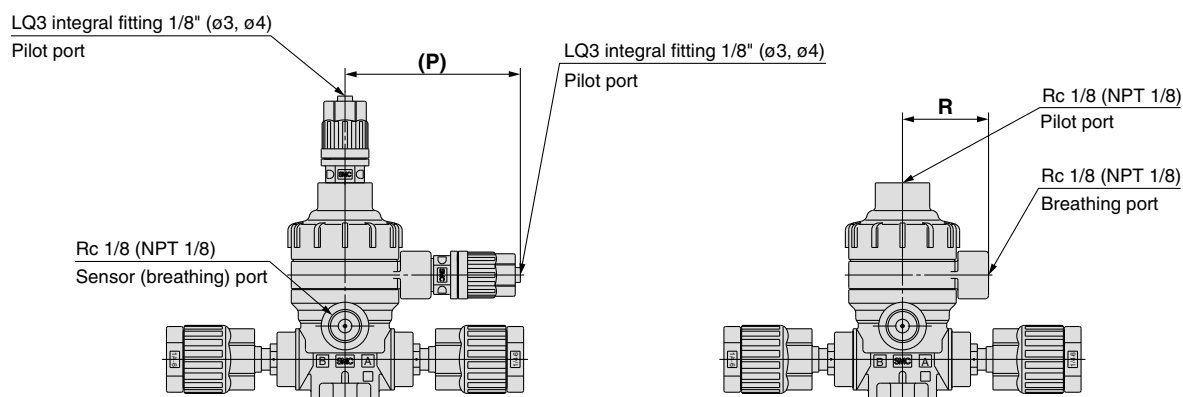

### LVQ□<sub>2</sub>S-Z□ Dimensions (N.O. valve, double acting valve)

(mm)

Model	A	B	C	D	E	F	G	H	J	K	L	M	N	P	Q	R	W
LVQ2 <sub>2</sub> S-Z□	25.5	46	31.5	58	33.6	89.5	12	105	21.8	37	5	7	15	53.5	21	25.3	64
LVQ3 <sub>2</sub> S-Z□	28.5	57	34.5	69	45.4	107.5	16.5	137	32	50	6	7	20	59.5	25	31.2	82
LVQ4 <sub>2</sub> S-Z□	28.5	57	34.5	69	45.4	113	22	151	37.5	55.5	6	7	20	59.5	25	31.2	87.5
LVQ5 <sub>2</sub> S-Z□	42	84	48	96	75	153.2	25	202	50.2	78.2	10	7	20	73	38.5	45	128
LVQ6 <sub>2</sub> S-Z□	42	84	48	96	75	163	32	236	60	88	10	7	20	73	38.5	45	137.5

With bypass  
Double acting valve

LVQ2 $\frac{1}{2}$ S

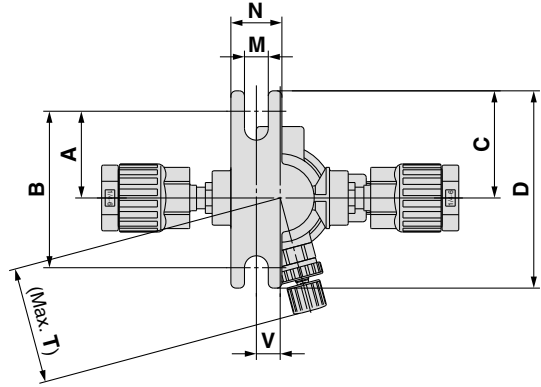
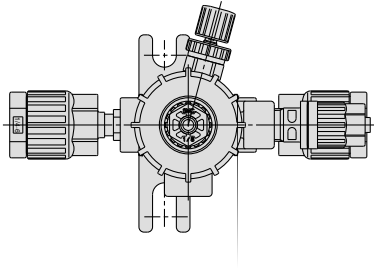

LVQ3 $\frac{1}{2}$ S, LVQ4 $\frac{1}{2}$ S  
LVQ5 $\frac{1}{2}$ S, LVQ6 $\frac{1}{2}$ S

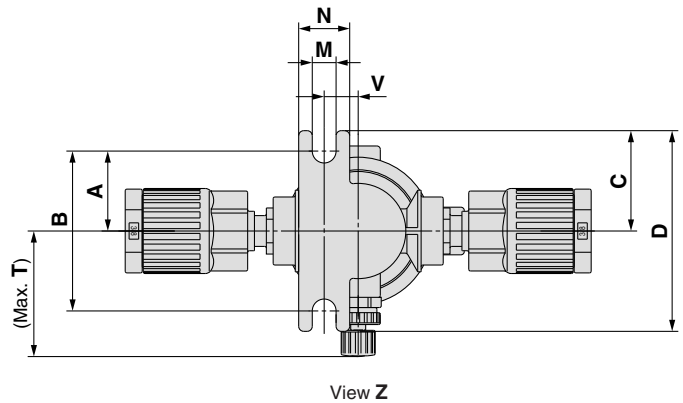
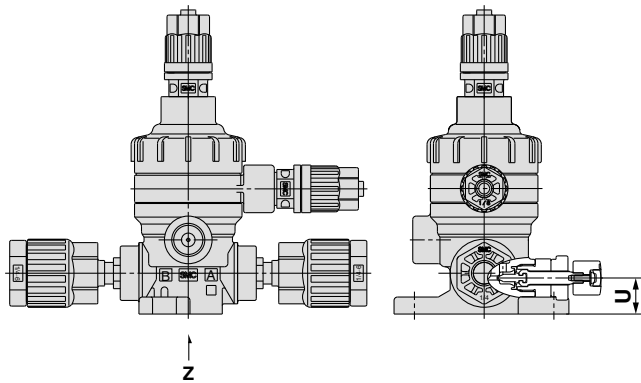

- LVC
- LVA
- LVH
- LVD
- LVQ**
- LQ1
- LVN
- TL/TIL
- LQ3

Dimensions (N.O. valve, double acting valve) (mm)

Model	A	B	C	D	M	N	T	U	V
LVQ2 $\frac{1}{2}$ -S-Z□-2	25.5	46	31.5	58	7	15	34.3	10.6	7
LVQ3 $\frac{1}{2}$ -S-Z□-2	25.5	51	31.5	63	7	15	36.9	16.5	10
LVQ4 $\frac{1}{2}$ -S-Z□-2	25.5	51	31.5	63	7	15	37.9	22	10
LVQ5 $\frac{1}{2}$ -S-Z□-2	38	76	44	88	7	20	64	25	17
LVQ6 $\frac{1}{2}$ -S-Z□-2	38	76	44	88	7	20	66	32	17

# Manual Type Flare Integral Fitting Type Hyper Fittings Series **LVQH-Z**

## How to Order

LVQH **2** 0 - Z **07**    - **1** -   

### Body class

Symbol	Body class	Orifice dia.
<b>2</b>	2	ø4
<b>3</b>	3	ø8
<b>4</b>	4	ø10
<b>5</b>	5	ø16
<b>6</b>	6	ø22

### Option

Symbol	Note
<b>Nil</b>	Standard
<b>K</b>	Buffer material FFKM
<b>N</b>	For ammonium hydroxide



Note) Options cannot be combined with each other.

### LQ3 integral fittings

### Applicable tubing size

Symbol	Connecting tubing O.D.	Body class					
		2	3	4	5	6	
<b>Metric sizes</b>							
<b>03</b>	ø3	○					
<b>04</b>	ø4	○					
<b>06</b>	ø6	○					
<b>08</b>	ø8		○				
<b>10</b>	ø10		○				
<b>12</b>	ø12			○			
<b>19</b>	ø19				○		
<b>25</b>	ø25					○	
<b>Inch sizes</b>							
<b>03</b>	1/8	○					
<b>07</b>	1/4	○					
<b>11</b>	3/8		○				
<b>13</b>	1/2			○			
<b>19</b>	3/4				○		
<b>25</b>	1					○	

### Handle operation

<b>1</b>	90 Degree turn type
<b>4</b>	Multi-turn type (with indicator)

### Breathing port thread type

<b>Nil</b>	Threaded	NPT 1/8
<b>R</b>	Threaded	Rc 1/8

## Variations

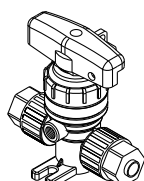
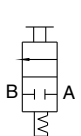
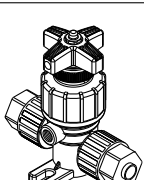
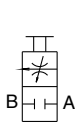
Type	Symbol	Model					
		LVQH20	LVQH30	LVQH40	LVQH50	LVQH60	
		Orifice diameter					
Tubing outside dia.		Millimeter	6	10	12	19	25
		Inch	1/4	3/8	1/2	3/4	1
<b>90 Degree turn type</b> 							
<b>Multi-turn type</b> 							

## Standard Specifications



Model		LVQH20	LVQH30	LVQH40	LVQH50	LVQH60
Tubing O.D.	Metric size	6	10	12	19	25
	Inch size	1/4	3/8	1/2	3/4	1
Orifice diameter		ø4	ø8	ø10	ø16	ø22
Flow characteristics	Av x 10 <sup>-6</sup> m <sup>2</sup>	8.4	31.2	45.6	120	192 (228) <sup>Note)</sup>
	Cv	0.35	1.3	1.9	5	8 (9.5) <sup>Note)</sup>
Withstand pressure (MPa)		1				
Operating pressure <A→B flow>		-98 kPa to 0.5 MPa			-98 kPa to 0.4 MPa	
Back pressure (MPa)		0.3 or less			0.2 or less	
Valve leakage (cm <sup>3</sup> /min)		0 (With water pressure)				
Fluid temperature (°C)		0 to 100				
Ambient temperature (°C)		0 to 60				
Mass (kg)	LVQH□0-1	0.12	0.27	0.32	1.14	1.20
	LVQH□0-4	0.11	0.25	0.23	0.72	0.82

Note) ( ) is high flow specification.

LVC

LVA

LVH

LVD

LVQ

LQ1

LVN

TL/TIL

LQ3

## ⚠ Specific Product Precautions

Be sure to read before handling. Refer to front matters 42 and 43 for Safety Instructions, and pages 585 and 586 for High Purity Chemical Valve Non-Metallic Exterior Precautions.

### Piping

## ⚠ Caution

### 1. Connect tubing with special tools.

Refer to the pamphlet "High-Purity Fluoropolymer Fittings HYPER FITTING®/Flare Type Series LQ3 Fitting Procedure" (M-E06-4) for connecting tubing and special tools. (Downloadable from our web site.)

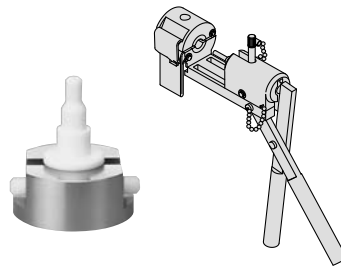

### 2. Tighten the nut to the end surface of the body. As a guide, refer to the proper tightening torques shown below.

#### Tightening torque for piping

Body class	Torque (N·m)
2	1.6 to 1.8
3	3.2 to 3.5
4	5.0 to 5.3
5	10.0 to 10.5
6	22.5 to 23.0



# Series LVQH-Z

## Construction

### 90 Degree turn type

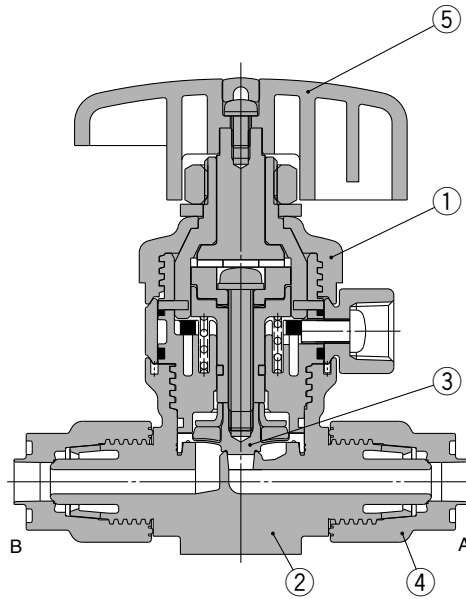

### Multi-turn type (with indicator)

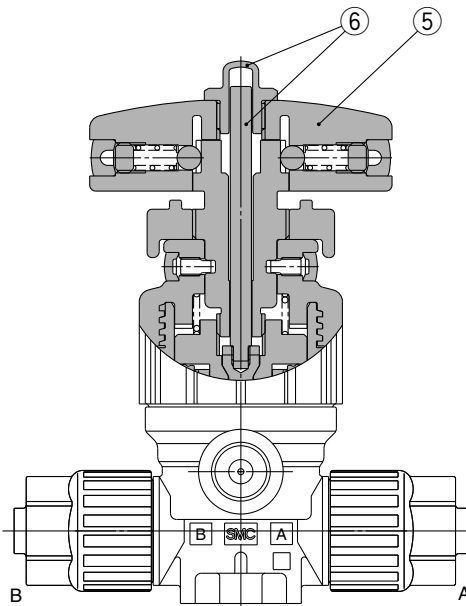

### Parts list

No.	Description	Material
1	Actuator section	PVDF
2	Body	PFA
3	Diaphragm	PTFE
4	Nut	PFA
5	Handle section	PVDF
6	Indicator, cover	PP

## Dimensions

### 90 Degree turn type

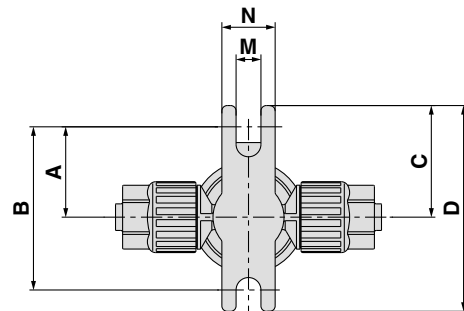
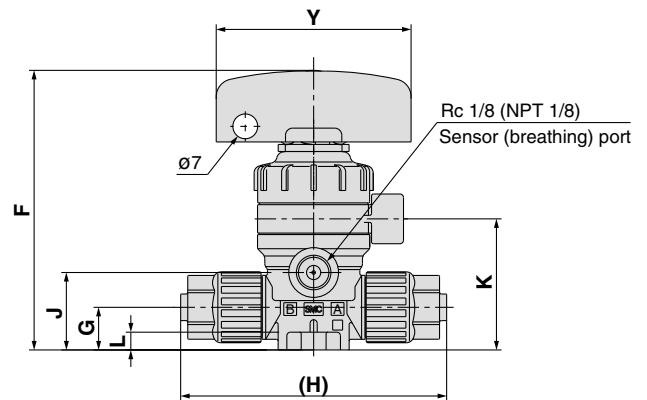
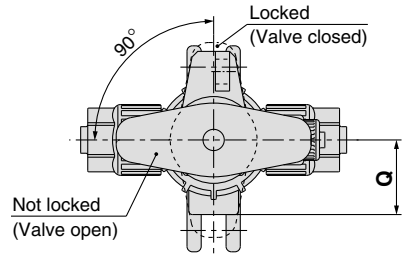

Dimensions (mm)

Model	A	B	C	D	F	G	H
LVQH20-Z□□-1	25.5	46	31.5	58	79	12	75
LVQH30-Z□□-1	28.5	57	34.5	69	103	16.5	103
LVQH40-Z□□-1	28.5	57	34.5	69	108	22	114
LVQH50-Z□□-1	42	84	48	96	165	25	150
LVQH60-Z□□-1	42	84	48	96	175	32	167

Model	J	K	L	M	N	Q	Y
LVQH20-Z□□-1	21.8	37	5	7	15	21	55
LVQH30-Z□□-1	32	50	6	7	20	25	80
LVQH40-Z□□-1	37.5	55.5	6	7	20	25	80
LVQH50-Z□□-1	50.2	78.2	10	7	20	38.5	110
LVQH60-Z□□-1	60	88	10	7	20	38.5	110

### Multi-turn type (with indicator)

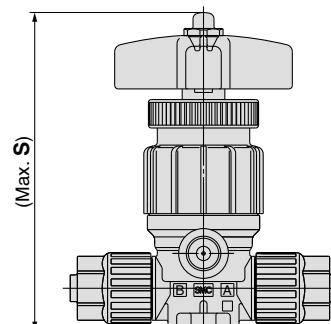
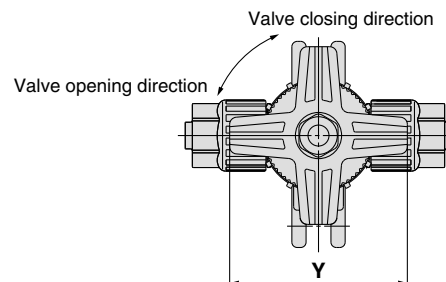

Dimensions (mm)

Model	S	Y
LVQH20-Z□-4	89.6	50
LVQH30-Z□-4	107.2	50
LVQH40-Z□-4	112.7	50
LVQH50-Z□-4	165	71
LVQH60-Z□-4	174.5	71

LVC

LVA

LVH

LVD

**LVQ**

LQ1

LVN

TL/TIL

LQ3

# Manual Type Flare Integral Fitting Type Space Saving/Space Saving Connection Series **LVQHS-Z**

## How to Order

LVQH **2** **0** **S** - **Z** **07** **□** - **1** - **□**

### Body class

Symbol	Body class	Orifice dia.
<b>2</b>	2	ø4
<b>3</b>	3	ø8
<b>4</b>	4	ø10
<b>5</b>	5	ø16
<b>6</b>	6	ø22

### Body type

<b>S</b>	Space saving connection
----------	-------------------------

### LQ3 integral fittings

### Option

Symbol	Note
<b>Nil</b>	Standard
<b>K</b>	Buffer material FFKM
<b>N</b>	For ammonium hydroxide



Note) Options cannot be combined with each other.

### Handle operation

<b>1</b>	90 Degree turn type
<b>4</b>	Multi-turn type (with indicator)

### Breathing port thread type

<b>Nil</b>	Threaded	NPT 1/8
<b>R</b>	Threaded	Rc 1/8

### Applicable fitting size

Symbol	Connecting tubing O.D.	Body class				
		2	3	4	5	6
<b>Inch sizes</b>						
<b>07</b>	1/4	○				
<b>11</b>	3/8		○			
<b>13</b>	1/2			○		
<b>19</b>	3/4				○	
<b>25</b>	1					○



Note) Refer to page 567 for How to order fitting parts.

Select the fittings of the same size as the one at the valve side.

## Variations

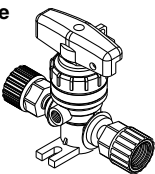
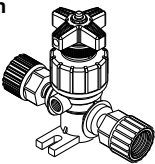
Type	Model	Orifice diameter				
		LVQ20S	LVQ30S	LVQ40S	LVQ50S	LVQ60S
		Connection diameter				
		Symbol				
		2	3	4	5	6
<b>90 Degree turn type</b>		○	○	○	○	○
<b>Multi-turn type</b>		○	○	○	○	○

**How to Order Fittings for Space Saving**

**LQ3 E 6A - S**

• One nut of the nuts is not attached.

Type of fitting

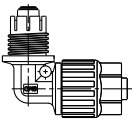
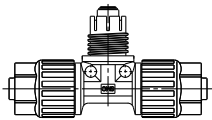
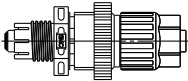
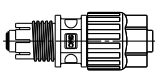
E	T
Union elbow 	Union tee 
P	U
Panel mount union 	Union 

• Applicable tubing size

Size	Symbol	Applicable tubing size (inch)
2	A	1/4" x 5/32"
3	A	3/8" x 1/4"
4	A	1/2" x 3/8"
5	A	3/4" x 5/8"
6	A	1" x 7/8"

Note 1) Select a fitting the same size as the valve fitting.

LVC

LVA

LVH

LVD

**LVQ**

LQ1

LVN

TL/TIL

LQ3

**Piping example**

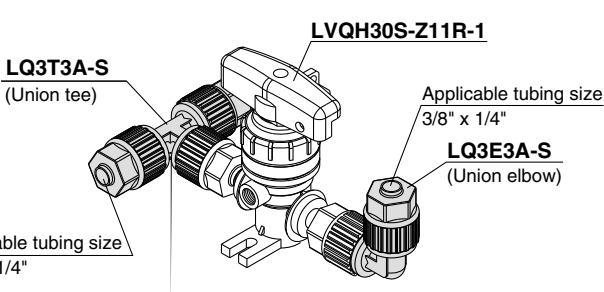

**LQ3T3A-S**  
(Union tee)

**LVQH30S-Z11R-1**

Applicable tubing size  
3/8" x 1/4"

**LQ3E3A-S**  
(Union elbow)

Applicable tubing size  
3/8" x 1/4"

**Example**

<b>LVQH30S-Z11R-1</b>	1
<b>LQ3T3A-S</b> (Union tee)	1
<b>LQ3E3A-S</b> (Union elbow)	1

Note) For shipment, the valve and fittings are individually packaged and dispatched together in 1 box.



## Standard Specifications

Model		LVQH20S	LVQH30S	LVQH40S	LVQH50S	LVQH60S
Connection fitting size		2	3	4	5	6
Orifice diameter		ø4	ø8	ø10	ø16	ø22
Flow characteristics	Av x 10 <sup>-6</sup> m <sup>2</sup>	8.4	31.2	45.6	120	192 (228) <sup>Note)</sup>
	Cv	0.35	1.3	1.9	5	8 (9.5) <sup>Note)</sup>
Withstand pressure (MPa)		1				
Operating pressure <A→B flow>		-98 kPa to 0.5 MPa			-98 kPa to 0.4 MPa	
Back pressure (MPa)		0.3 or less			0.2 or less	
Valve leakage (cm <sup>3</sup> /min)		0 (With water pressure)				
Fluid temperature (°C)		0 to 100				
Ambient temperature (°C)		0 to 60				
Mass (kg)	LVQH□0S-1	0.14	0.28	0.34	1.14	1.15
	LVQH□S0-4	0.13	0.21	0.25	0.72	0.86

Note) ( ) is high flow specification.

## ⚠ Specific Product Precautions

Be sure to read before handling. Refer to front matters 42 and 43 for Safety Instructions, and pages 585 and 586 for High Purity Chemical Valve Non-Metallic Exterior Precautions.

### Piping

## ⚠ Caution

1. Tighten the nut to the end surface of the body. As a guide, refer to the proper tightening torques shown below.

#### Tightening torque for piping

Body class	Torque (N·m)
2	1.6 to 1.8
3	3.2 to 3.5
4	5.0 to 5.3
5	10.0 to 10.5
6	22.5 to 23.0

## Construction

### 90 Degree turn type

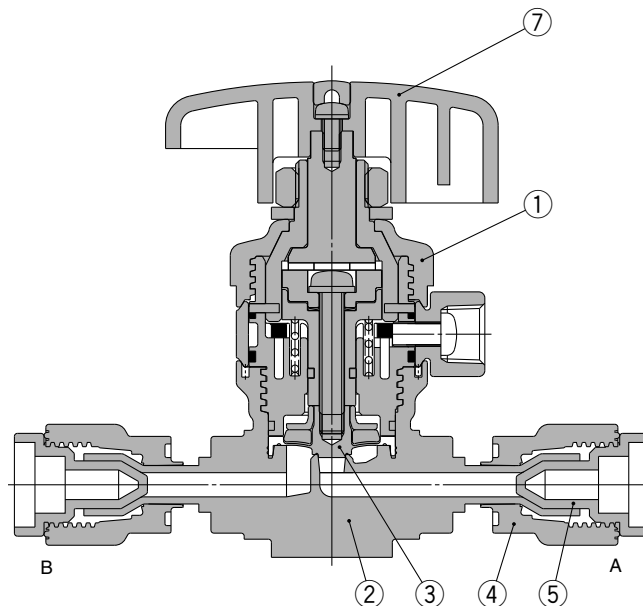

- LVC
- LVA
- LVH
- LVD
- LVQ**
- LQ1
- LVN
- TL/TIL
- LQ3

### Multi-turn type (with indicator)

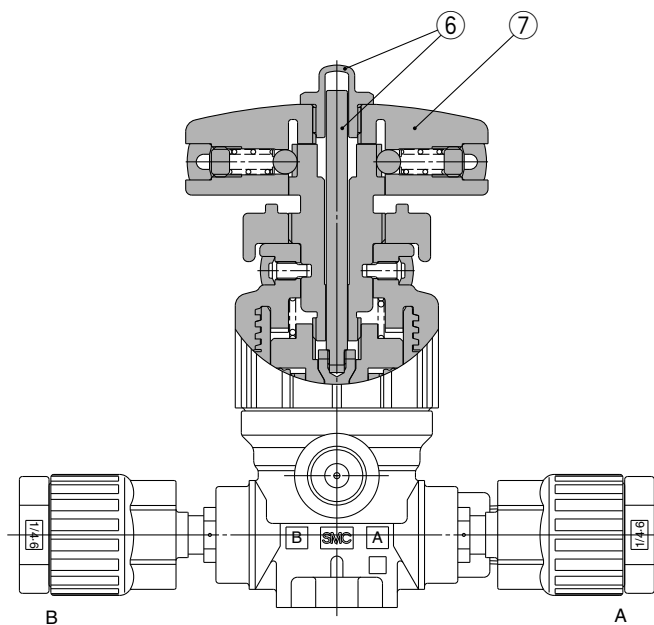

### Parts list

No.	Description	Material
1	Actuator section	PVDF
2	Body	PFA
3	Diaphragm	PTFE
4	Nut	PFA
5	Plug	PFA
6	Indicator, cover	PP
7	Handle section	PVDF

# Series LVQHS-Z

## Dimensions

### 90 Degree turn type

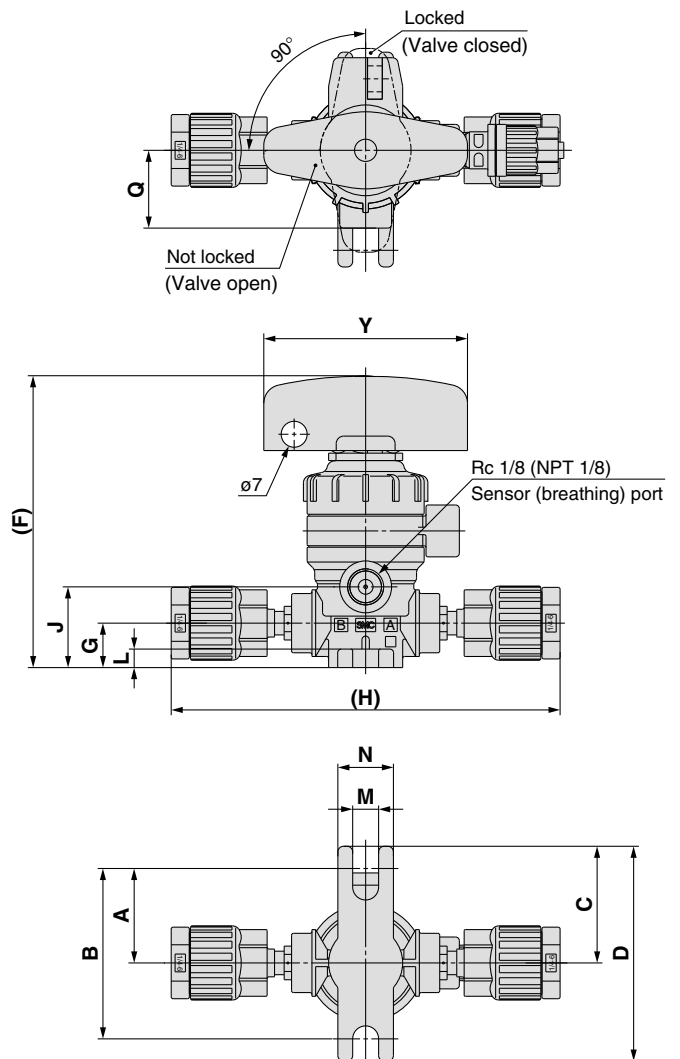

Dimensions (mm)

Model	A	B	C	D	F	G	H
LVQH20S-Z□-1	25.5	46	31.5	58	79	12	105
LVQH30S-Z□-1	28.5	57	34.5	69	103	16.5	137
LVQH40S-Z□-1	28.5	57	34.5	69	108	22	151
LVQH50S-Z□-1	42	84	48	96	165	25	202
LVQH60S-Z□-1	42	84	48	96	175	32	236

Model	J	K	L	M	N	Q	Y
LVQH20S-Z□-1	21.8	37	5	7	15	21	55
LVQH30S-Z□-1	32	50	6	7	20	25	80
LVQH40S-Z□-1	37.5	55.5	6	7	20	25	80
LVQH50S-Z□-1	50.2	78.2	10	7	20	38.5	110
LVQH60S-Z□-1	60	88	10	7	20	38.5	110

### Multi-turn type (with indicator)

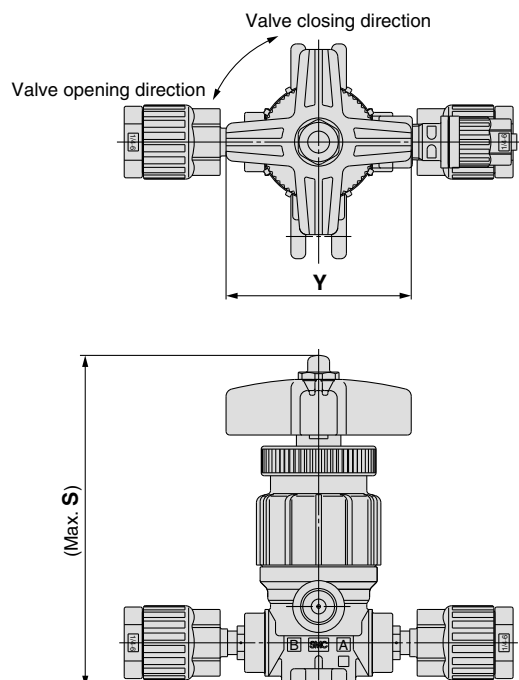

Dimensions (mm)

Model	S	Y
LVQH20S-Z□-4	89.6	50
LVQH30S-Z□-4	107.2	50
LVQH40S-Z□-4	112.7	50
LVQH50S-Z□-4	165	71
LVQH60S-Z□-4	174.5	71

# Air Operated Type Tube Extension Fitting Type Series **LVQ-T**

## How to Order

LVQ **2** **0** - T **07**    -    -   

### Body class

Symbol	Body class	Orifice dia.
2	2	ø4
3	3	ø8
4	4	ø10
5	5	ø16
6	6	ø22

### Valve type

0	N.C.
1	N.O.
2	Double acting

Note) Refer to variations in the table below for valve type combinations.

### Tube Extension Fitting

### Applicable tubing size

Symbol	Connecting tubing O.D.	Body class					
		2	3	4	5	6	
<b>Metric sizes</b>							
06	ø6	○					
10	ø10		○				
12	ø12			○			
19	ø19				○		
25	ø25					○	
<b>Inch sizes</b>							
07	1/4	○					
11	3/8		○				
13	1/2			○			
19	3/4				○		
25	1					○	

### Pilot port thread type

Nil	LQ1 integral fitting	Connection tubing O.D. 1/8" (ø3)
M	LQ1 integral fitting	Connection tubing O.D. ø4
R	Threaded	Rc 1/8
N	Threaded	NPT 1/8

### Option (2)

Symbol	Applicable option										Note	
	1	2	3	4	5	6	7	8	9	24		
Nil	○	○	○	○	○	○	○	○	○	○	—	—
J	○	—	—	—	—	—	—	—	—	—	—	For high temperature
K	○	○	○	○	○	○	○	○	○	○	○	Buffer material FFKM
N	○	○	○	○	○	○	○	○	○	○	○	For ammonium hydroxide
P	—	—	—	○	○	—	—	—	—	—	—	High flow spec. LVQ6□ only













































### Option (1)

Nil	None	5	High back pressure (0.42 MPa)
1	With flow rate adjustment	6	High back pressure with flow rate adjustment
2	With bypass	7	High back pressure with bypass
3	With flow rate adjustment & bypass	8	High back pressure with flow rate adjustment & bypass
4	With indicator	9	High back pressure with indicator

Note) Options (2) cannot be combined with each other.

Note) Refer to variations in the table below for valve type and option (1) combinations. Options (1) can not be combined with each other.

## Variations

Type	Symbol	Model	Orifice diameter				
			LVQ20	LVQ30	LVQ40	LVQ50	LVQ60
			ø4	ø8	ø10	ø16	ø22
		Tubing outside dia.	Millimeter				
			6	10	12	19	25
		Valve type	Inch				
			1/4	3/8	1/2	3/4	1
Basic type N.C.  N.O.  Double acting 	 PA  PA  PA  PB  PB  PB	N.C.	○	○	○	○	○
		N.O.	○	○	○	○	○
		Double acting	○	○	○	○	○
With flow rate adjustment 	 PA  PA  PA  PB  PB  PB	N.C.	○	○	○	○	○
		Double acting	○	○	○	○	○
With bypass  N.C.  Double acting 	 PA  PA  PB  PB	N.C.	○	○	○	○	○
		Double acting	○	○	○	○	○
With flow rate adjustment & bypass 	 PA  PA  PA  PB  PB  PB	N.C.	○	○	○	○	○
With indicator 	 PA  PA  PA  PB  PB  PB	N.C.	○	○	○	○	○
High back pressure 	 PA  PA  PA  PB  PB  PB	N.C.	○	○	○	○	○



# Series LVQ-T



## Standard Specifications

Model		LVQ20	LVQ30	LVQ40	LVQ50	LVQ60
Tubing O.D.	Metric size	6	10	12	19	25
	Inch size	1/4	3/8	1/2	3/4	1
Orifice diameter		ø4	ø8	ø10	ø16	ø22
Flow characteristics	$Av \times 10^{-6} m^2$	8.4	31.2	45.6	120	192 (228) <sup>Note)</sup>
	Cv	0.35	1.3	1.9	5	8 (9.5) <sup>Note)</sup>
Withstand pressure (MPa)		1				
Operating pressure <A→B flow>	Standard	-98 kPa to 0.5 MPa			-98 kPa to 0.4 MPa	
	High temperature	-98 kPa to 0.3 MPa				
Back pressure (MPa)	Standard	0.3 or less			0.2 or less	
	High back pressure	0.42 or less				
	High temperature	0.3 or less			0.2 or less	
Valve leakage (cm <sup>3</sup> /min)		0 (With water pressure)				
Pilot air pressure (MPa)		0.3 to 0.5 (High back pressure: 0.45 to 0.55)				
Pilot port size		1/8" (ø3), ø4, Rc 1/8, NPT 1/8				
Fluid temperature (°C)	Standard	0 to 100				
	High temperature	0 to 170				
Ambient temperature (°C)		0 to 60				
Mass (kg)		0.08	0.15	0.16	0.60	0.70

Note) ( ) is high flow specification.

## Construction

Basic type

N.C. type

N.O. type

Double acting type

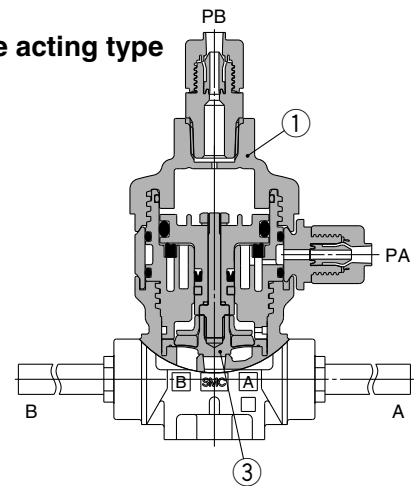
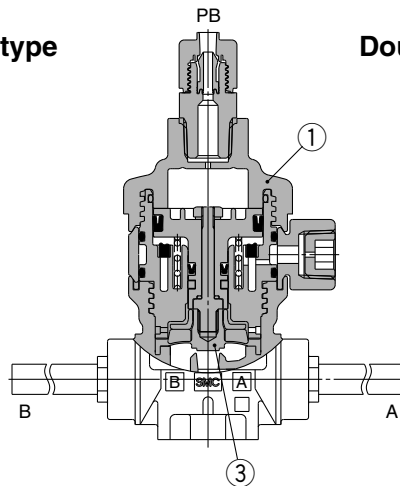
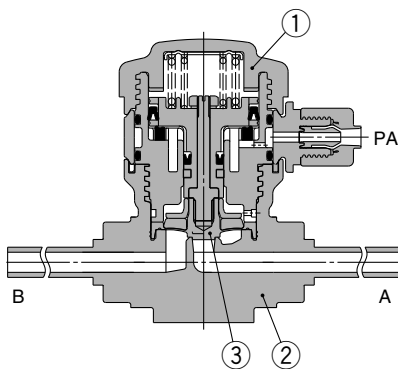

With flow rate adjustment

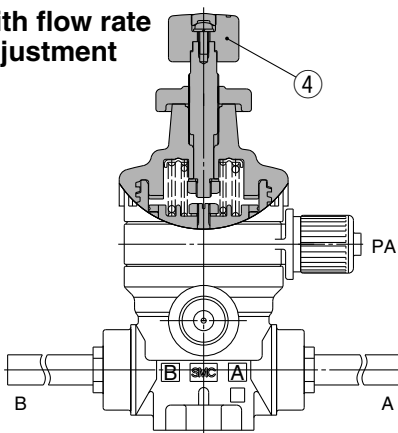

With bypass

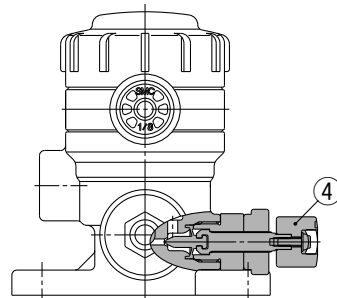

With indicator

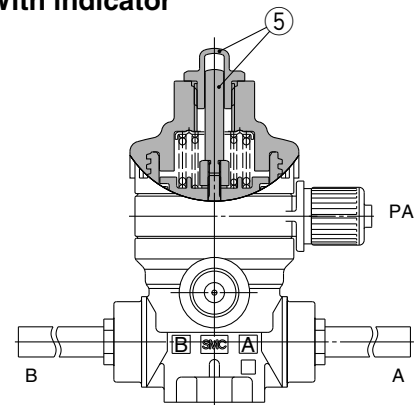

### Parts list

No.	Description	Material
1	Actuator section	PVDF
2	Body	PFA
3	Diaphragm	PTFE
4	Flow rate adjuster section	PVDF
5	Indicator, cover	PP

## Dimensions

Basic type, High back pressure spec.

N.C. valve

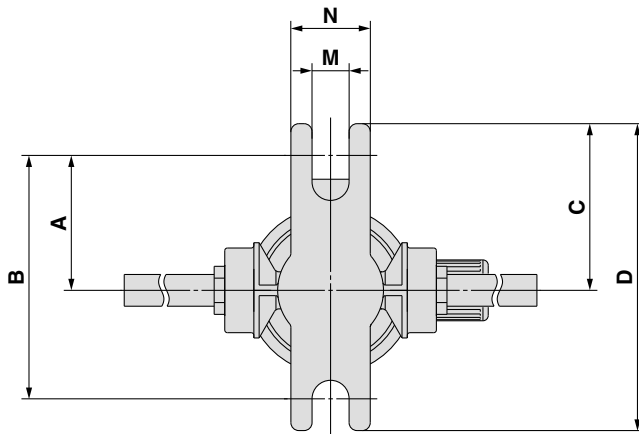
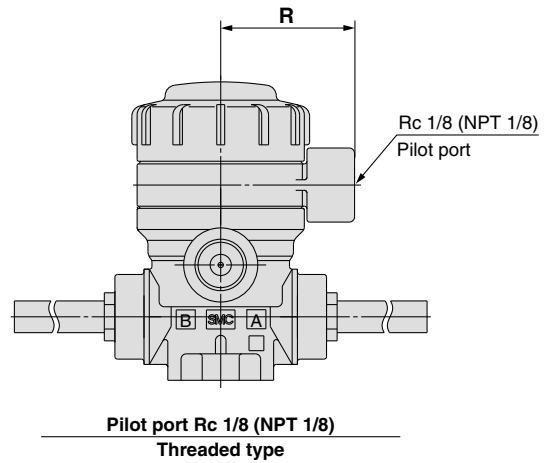
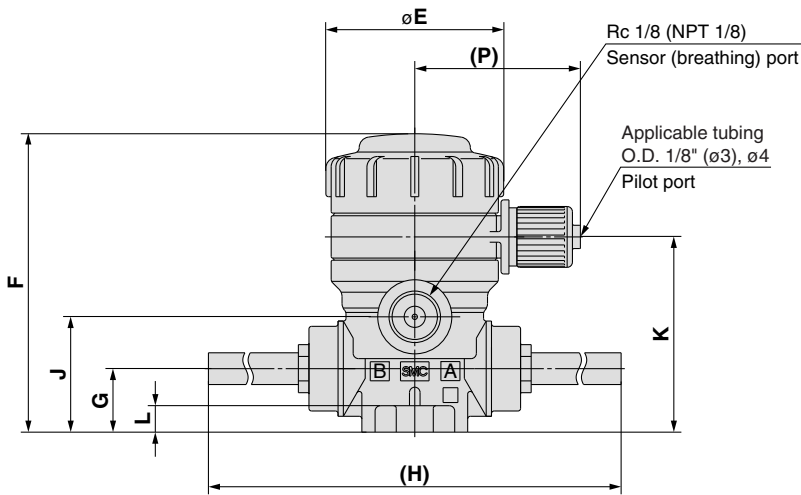
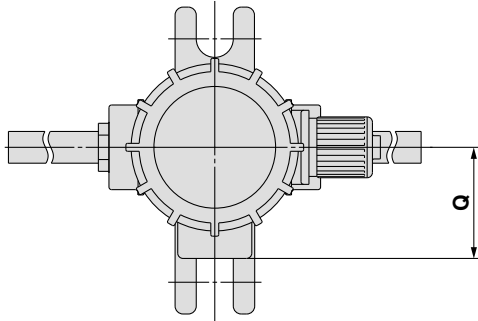

LVC

LVA

LVH

LVD

**LVQ**

LQ1

LVN

TL/TIL

LQ3

LVQ□0-T□ Dimensions (N.C. valve)

(mm)

Model	A	B	C	D	E	F	G	H	J	K	L	M	N	P	Q	R
LVQ20-T□	25.5	46	31.5	58	33.6	56.5	12	111.5	21.8	37	5	7	15	31.3	21	25.3
LVQ30-T□	28.5	57	34.5	69	45.4	77	16.5	136	32	50	6	7	20	37.2	25	31.2
LVQ40-T□	28.5	57	34.5	69	45.4	82.5	22	137	37.5	55.5	6	7	20	37.2	25	31.2
LVQ50-T□	42	84	48	96	75	127	25	180	50.2	78.2	10	7	20	50.8	38.5	45
LVQ60-T□	42	84	48	96	75	137	32	189	60	88	10	7	20	50.8	38.5	45

# Series LVQ-T

## Dimensions

With flow rate adjustment, High back pressure spec. with flow rate adjustment  
N.C. valve

Dimensions (mm)	
Model	S
LVQ20-T□-1	83
LVQ30-T□-1	113.5
LVQ40-T□-1	119
LVQ50-T□-1	171.5
LVQ60-T□-1	182.5

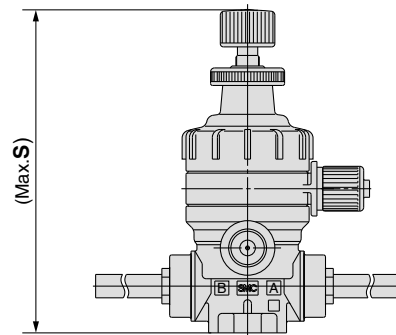

With bypass, High back pressure spec. with bypass  
N.C. valve

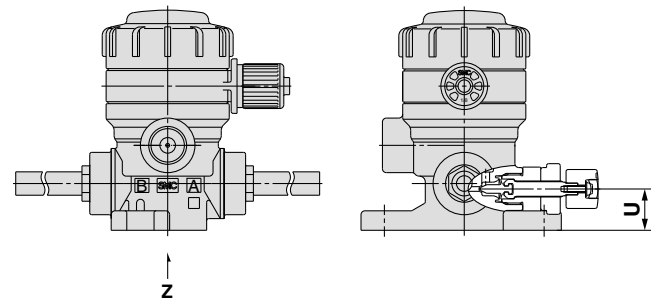
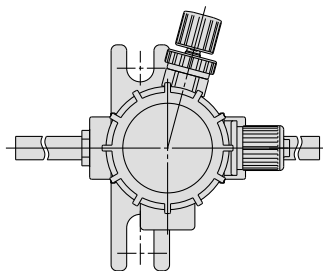

LVQ20

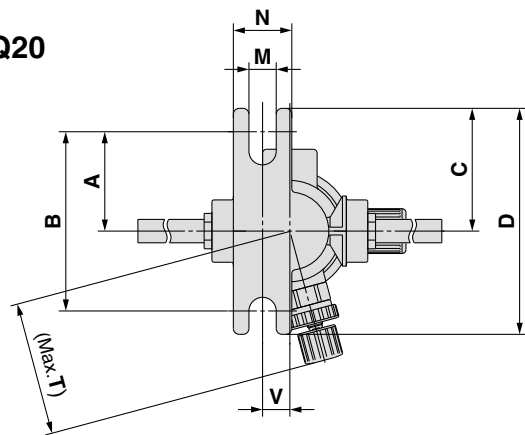

LVQ30, LVQ40  
LVQ50, LVQ60

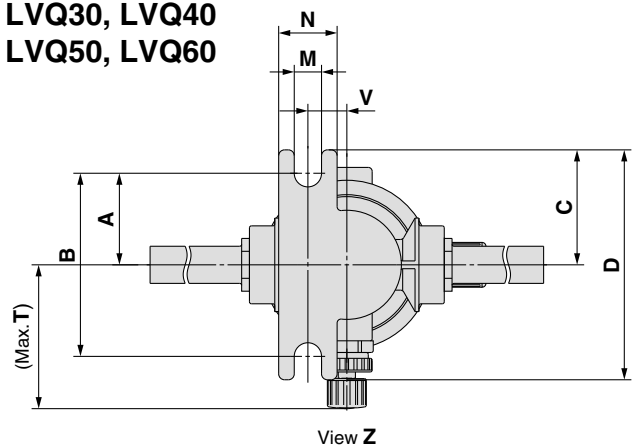

Dimensions (mm)									
Model	A	B	C	D	M	N	T	U	V
LVQ20-T□-2	25.5	46	31.5	58	7	15	34.3	10.6	7
LVQ30-T□-2	25.5	51	31.5	63	7	15	36.9	16.5	10
LVQ40-T□-2	25.5	51	31.5	63	7	15	37.9	22	10
LVQ50-T□-2	38	76	44	88	7	20	64	25	17
LVQ60-T□-2	38	76	44	88	7	20	66	32	17

With flow rate adjustment & bypass  
High back pressure spec. with flow rate  
adjustment & bypass  
N.C. valve

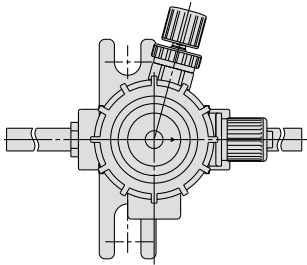

LVQ20

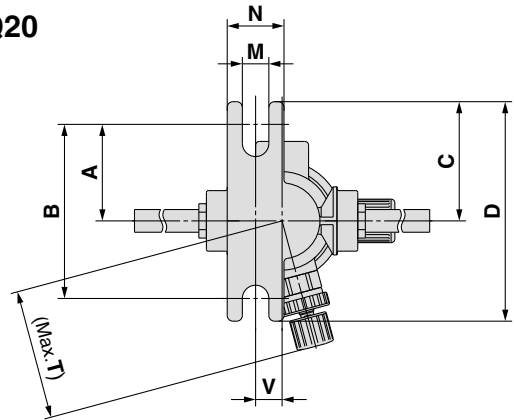

LVC

LVA

LVH

LVD

**LVQ**

LQ1

LVN

TL/TIL

LQ3

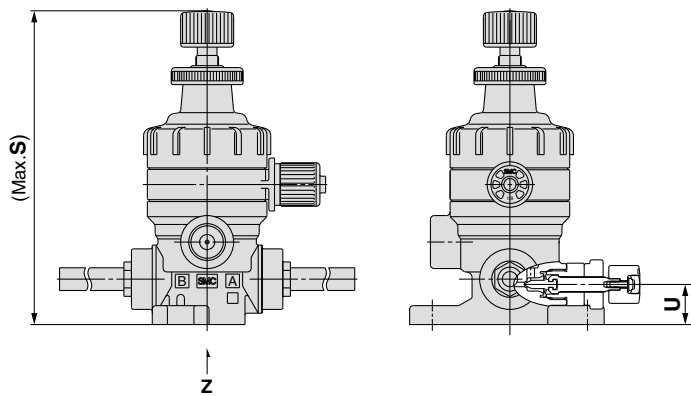

LVQ30, LVQ40  
LVQ50, LVQ60

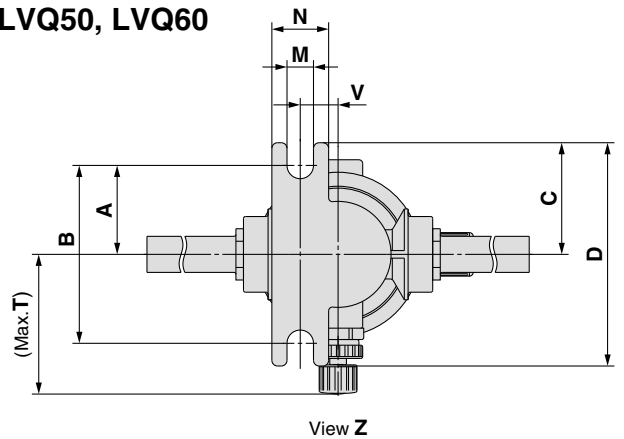

**Dimensions**

Model	A	B	C	D	M	N	S	T	U	V
LVQ20-T□-3	25.5	46	31.5	58	7	15	83	34.3	10.6	7
LVQ30-T□-3	25.5	51	31.5	63	7	15	113.5	36.9	16.5	10
LVQ40-T□-3	25.5	51	31.5	63	7	15	119	37.9	22	10
LVQ50-T□-3	38	76	44	88	7	20	171.5	64	25	17
LVQ60-T□-3	38	76	44	88	7	20	182.5	66	32	17

With indicator, High back pressure spec. with indicator  
N.C. valve

**Dimensions** (mm)

Model	S
LVQ20-T□-4	70.5
LVQ30-T□-4	88.5
LVQ40-T□-4	94
LVQ50-T□-4	134.5
LVQ60-T□-4	144

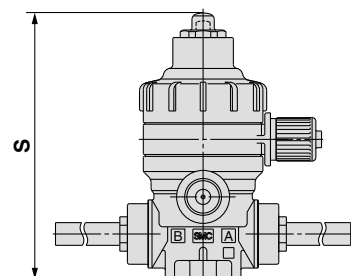

# Series LVQ-T

## Dimensions

### Basic type N.O. valve

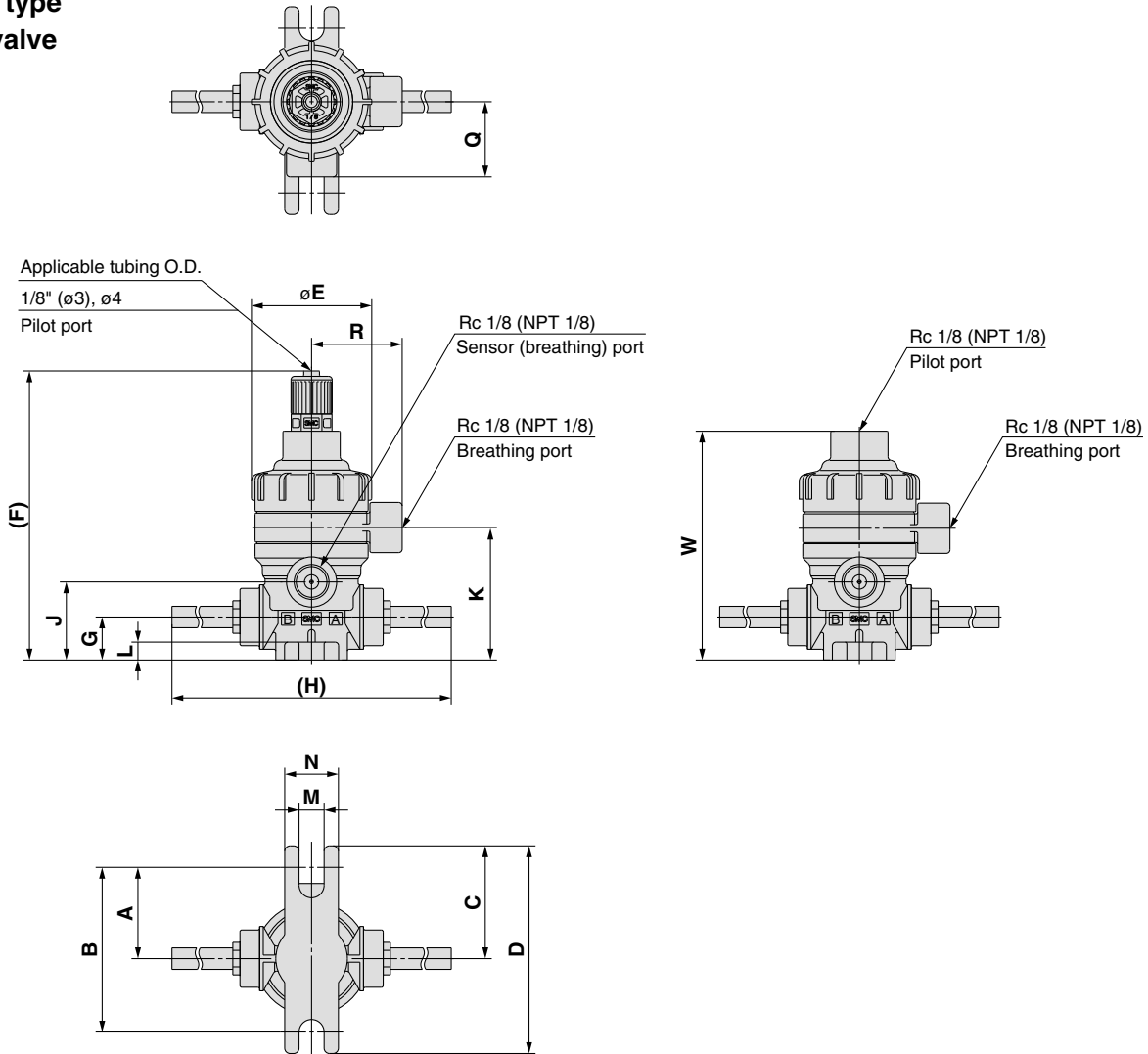

### Double acting valve

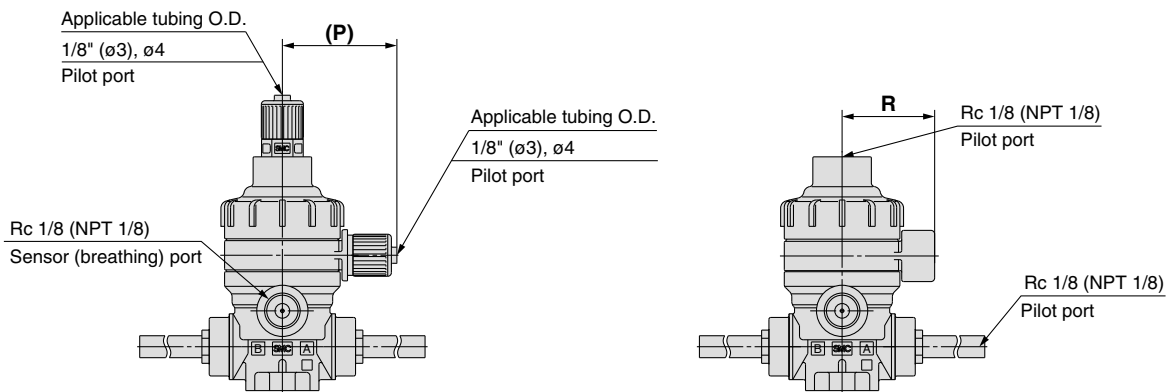

### LVQ□<sub>2</sub>-T□ Dimensions (N.O. valve, double acting valve)

(mm)

Model	A	B	C	D	E	F	G	H	J	K	L	M	N	P	Q	R	W
LVQ2 <sub>2</sub> -T□	25.5	46	31.5	58	33.6	81	12	111.5	21.8	37	5	7	15	31.3	21	25.3	64
LVQ3 <sub>2</sub> -T□	28.5	57	34.5	69	45.4	99	16.5	136	32	50	6	7	20	37.2	25	31.2	82
LVQ4 <sub>2</sub> -T□	28.5	57	34.5	69	45.4	104	22	137	37.5	55.5	6	7	20	37.2	25	31.2	87.5
LVQ5 <sub>2</sub> -T□	42	84	48	96	75	144.5	25	180	50.2	78.2	10	7	20	50.8	38.5	45	128
LVQ6 <sub>2</sub> -T□	42	84	48	96	75	154.5	32	189	60	88	10	7	20	50.8	38.5	45	137.5

**With bypass  
Double acting valve**

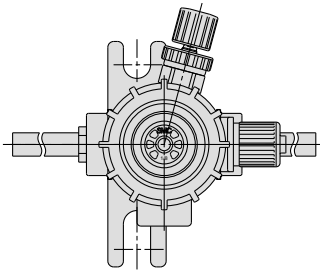

**LVQ2<sup>1</sup><sub>2</sub>**

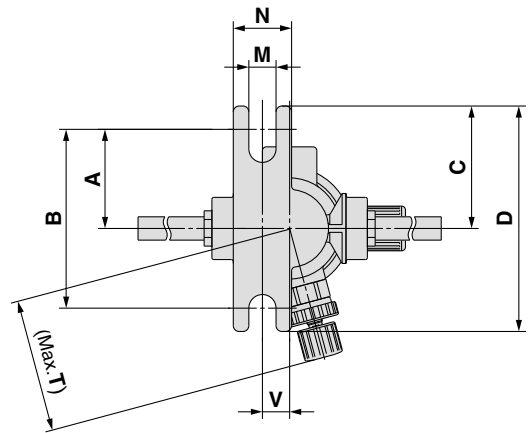

LVC

LVA

LVH

LVD

**LVQ**

LQ1

LVN

TL/TIL

LQ3

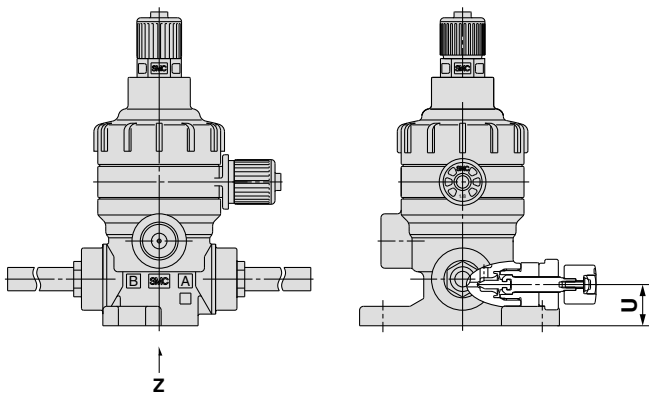

**LVQ3<sup>1</sup><sub>2</sub>, LVQ4<sup>1</sup><sub>2</sub>  
LVQ5<sup>1</sup><sub>2</sub>, LVQ6<sup>1</sup><sub>2</sub>**

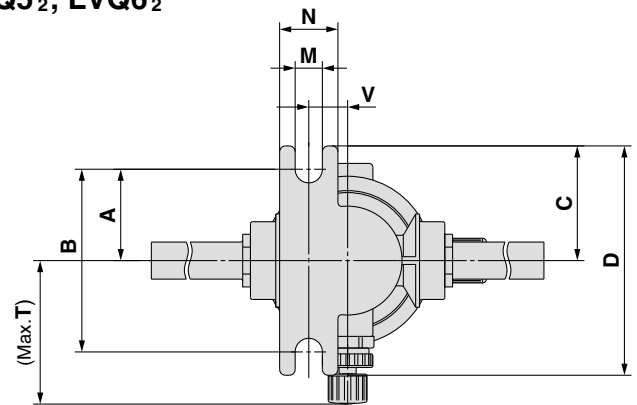

View Z

**Dimensions**

(mm)

Model	A	B	C	D	M	N	T	U	V
LVQ2 <sup>1</sup> <sub>2</sub> -T□-2	25.5	46	31.5	58	7	15	34.3	10.6	7
LVQ3 <sup>1</sup> <sub>2</sub> -T□-2	25.5	51	31.5	63	7	15	36.9	16.5	10
LVQ4 <sup>1</sup> <sub>2</sub> -T□-2	25.5	51	31.5	63	7	15	37.9	22	10
LVQ5 <sup>1</sup> <sub>2</sub> -T□-2	38	76	44	88	7	20	64	25	17
LVQ6 <sup>1</sup> <sub>2</sub> -T□-2	38	76	44	88	7	20	64	32	17

# Manual Type Tube Extension Fitting Type Series **LVQH-T**

## How to Order

LVQH **2** 0 - T **07**    - **1** -   

### Body class

Symbol	Body class	Orifice dia.
<b>2</b>	2	ø4
<b>3</b>	3	ø8
<b>4</b>	4	ø10
<b>5</b>	5	ø16
<b>6</b>	6	ø22

### Option

Symbol	Note
<b>Nil</b>	Standard
<b>K</b>	Buffer material FFKM
<b>N</b>	For ammonium hydroxide



Note) Options cannot be combined with each other.

### Tube Extension Fitting

### Applicable tubing size

Symbol	Connecting tubing O.D.	Body class				
		2	3	4	5	6
<b>Metric sizes</b>						
<b>06</b>	ø6	○				
<b>10</b>	ø10		○			
<b>12</b>	ø12			○		
<b>19</b>	ø19				○	
<b>25</b>	ø25					○
<b>Inch sizes</b>						
<b>07</b>	1/4	○				
<b>11</b>	3/8		○			
<b>13</b>	1/2			○		
<b>19</b>	3/4				○	
<b>25</b>	1					○

### Handle operation

<b>1</b>	90 Degree turn type
<b>4</b>	Multi-turn type (with indicator)

### Breathing port thread type

<b>Nil</b>	Threaded	NPT 1/8
<b>R</b>	Threaded	Rc 1/8

## Variations

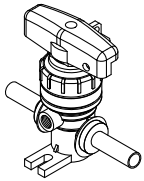
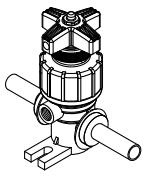
Type	Symbol	Model	Connection fitting size				
			Orifice diameter				
			Millimeter	Millimeter	Inch	Millimeter	Inch
			<b>LVQH20-T</b>	<b>LVQH30-T</b>	<b>LVQH40-T</b>	<b>LVQH50-T</b>	<b>LVQH60-T</b>
			ø4	ø8	ø10	ø16	ø22
			6	10	12	19	25
			1/4	3/8	1/2	3/4	1
<b>90 Degree turn type</b>			○	○	○	○	○
<b>Multi-turn type</b>			○	○	○	○	○

### Standard Specifications



Model		LVQH20	LVQH30	LVQH40	LVQH50	LVQH60
Tubing O.D.	Metric size	6	10	12	19	25
	Inch size	1/4	3/8	1/2	3/4	1
Orifice diameter		ø4	ø8	ø10	ø16	ø22
Flow characteristics	$Av \times 10^{-6} m^2$	8.4	31.2	45.6	120	192 (228) <sup>Note)</sup>
	Cv	0.35	1.3	1.9	5	8 (9.5) <sup>Note)</sup>
Withstand pressure (MPa)		1				
Operating pressure <A→B flow>		-98 kPa to 0.5 MPa			-98 kPa to 0.4 MPa	
Back pressure (MPa)		0.3 or less			0.2 or less	
Valve leakage (cm <sup>3</sup> /min)		0 (With water pressure)				
Fluid temperature (°C)		0 to 100				
Ambient temperature (°C)		0 to 60				
Mass (kg)	LVQH□0-1	0.12	0.25	0.28	1.04	1.05
	LVQH□0-4	0.11	0.18	0.19	0.62	0.73

Note) ( ) is high flow specification.

### Construction

#### 90 Degree turn type

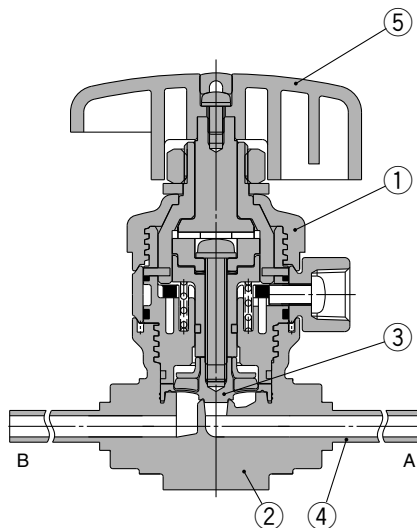

#### Multi-turn type (with indicator)

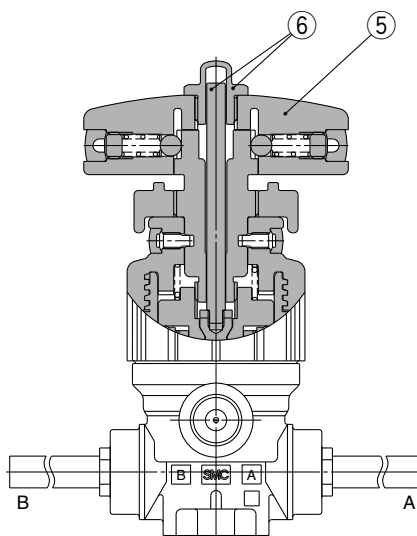

#### Parts list

No.	Description	Material
1	Actuator section	PVDF
2	Body	PFA
3	Diaphragm	PTFE
4	Insert bushing	PFA
5	Handle section	PVDF
6	Indicator, cover	PP

LVC

LVA

LVH

LVD

LVQ

LQ1

LVN

TL/TIL

LQ3



# Series LVQH-T

## Dimensions

### 90 Degree turn type

#### Dimensions

(mm)

Model	A	B	C	D	F	G	H
LVQH20-T□-1	25.5	46	31.5	58	79	12	111.5
LVQH30-T□-1	28.5	57	34.5	69	103	16.5	136
LVQH40-T□-1	28.5	57	34.5	69	108	22	137
LVQH50-T□-1	42	84	48	96	165	25	180
LVQH60-T□-1	42	84	48	96	175	32	189

Model	J	K	L	M	N	Q	Y
LVQH20-T□-1	21.8	37	5	7	15	21	55
LVQH30-T□-1	32	50	6	7	20	25	80
LVQH40-T□-1	37.5	55.5	6	7	20	25	80
LVQH50-T□-1	50.2	78.2	10	7	20	38.5	110
LVQH60-T□-1	60	88	10	7	20	38.5	110

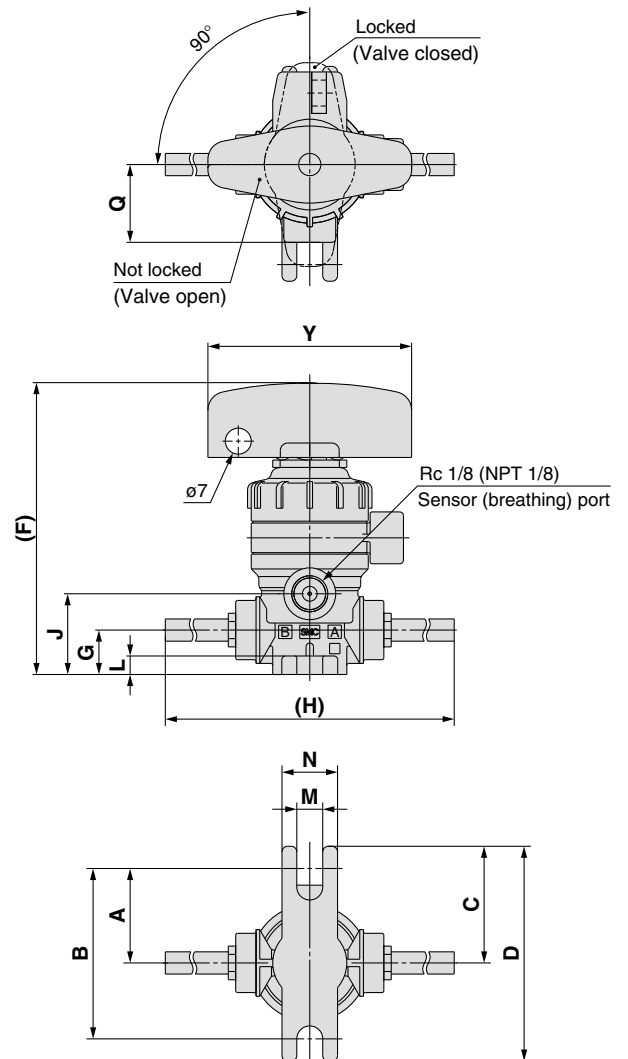

### Multi-turn type (with indicator)

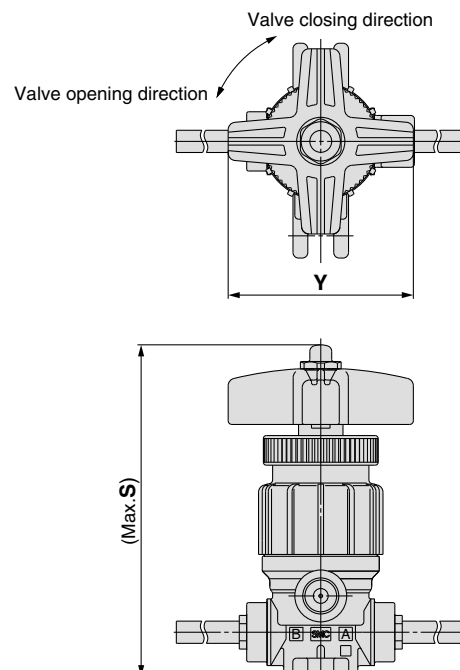

#### Dimensions

(mm)

Model	S	Y
LVQH20-T□-4	89.6	50
LVQH30-T□-4	107.2	50
LVQH40-T□-4	112.7	50
LVQH50-T□-4	165	71
LVQH60-T□-4	174.5	71

# Air Operated Type for Back Pressure 0.5 MPa Integral Fitting Type (Hyper Fittings)

## Series LVQ□□H

### How to Order

**LVQ 2 0 H - S 07** — **Option**

Symbol	Body class	Orifice dia.
2	2	ø4
3	3	ø8
4	4	ø10
5	5	ø16
6	6	ø22

**Valve type**

0	N.C.
1	N.O.
2	Double acting

Note) Refer to variations in the table below for valve type combinations.

Option	Description
Nil	None
1	With flow rate adjustment
2	With bypass
3	With flow rate adjustment & bypass
4	With indicator
24	With indicator & bypass

**Pilot port thread type**

Nil	LQ1 integral fitting	Connection tubing O.D. 1/8" (ø3)
M	LQ1 integral fitting	Connection tubing O.D. ø4
R	Threaded	Rc 1/8
N	Threaded	NPT 1/8

**Port B (OUT) different dia. size**

Symbol	Application
Nil	Ports A & B same size
Refer to the applicable tubing table to the left.	Different diameter tubings can be selected within the same body class.

**Fitting type**

Symbol	Fittings	Body class
V	LQ1	2, 3, 4, 5, 6
S	LQ2	2, 3, 4, 5

**Applicable tubing size**

Symbol	Connecting tubing O.D.	Body class					
		2	3	4	5	6	
<b>Metric sizes</b>							
03	ø3	●					
04	ø4	●					
06	ø6	○	●				
08	ø8		●				
10	ø10		○	●			
12	ø12			○	●		
19	ø19				○	●	
25	ø25					○	●
<b>Inch sizes</b>							
03	1/8	●					
05	3/16	●					
07	1/4	○	●				
11	3/8		○	●			
13	1/2			○	●		
19	3/4				○	●	
25	1					○	●

○ Basic size ● With reducer

- LVC
- LVA
- LVH
- LVJ
- LVK
- LVQ
- LQ1
- LVN
- TL/TIL
- LQ3

### Variations

Type	Symbol	Model	Orifice diameter				
			Tubing outside dia.				
			LVQ20H	LVQ30H	LVQ40H	LVQ50H	LVQ60H
			ø4	ø8	ø10	ø16	ø22
			6	10	12	19	25
			1/4	3/8	1/2	3/4	1
			Valve type				
			N.C.	N.O.	Double acting		
<b>Basic type</b>			○	○	○	○	○
<b>With flow rate adjustment</b>			○	○	○	○	○
<b>With bypass</b>			○	○	○	○	○
<b>With flow rate adjustment &amp; bypass</b>			○	○	○	○	○
<b>With indicator</b>			○	○	○	○	○
<b>With indicator &amp; bypass</b>			○	○	○	○	○

# Air Operated Type for Back Pressure 0.5 MPa Flare Integral Fitting Type (Hyper Fittings)

## Series LVQ□□H-Z

### How to Order

LVQ 2 0 H-Z 07 □ - □

#### Body class

Symbol	Body class	Orifice dia.
2	2	ø4
3	3	ø8
4	4	ø10
5	5	ø16
6	6	ø22

#### Valve type

0	N.C.
1	N.O.
2	Double acting



Note) Refer to variations in the table below for valve type combinations.

LQ3  
integral  
fittings

#### Option

Nil	None
1	With flow rate adjustment
2	With bypass
3	With flow rate adjustment & bypass
4	With indicator
24	With indicator & bypass



Note) Refer to variations in the table below for valve type and option combinations. Options can not be combined with each other.

#### Applicable tubing size

Symbol	Connecting tubing O.D.	Body class					
		2	3	4	5	6	
<b>Metric sizes</b>							
03	ø3	○					
04	ø4	○					
06	ø6	○					
08	ø8		○				
10	ø10		○				
12	ø12			○			
19	ø19				○		
25	ø25					○	
<b>Inch sizes</b>							
07	1/4	○					
11	3/8		○				
13	1/2			○			
19	3/4				○		
25	1					○	

#### Pilot port thread type

Nil	LQ3 integral fitting	Connection tubing O.D. 1/8" (ø3)
M	LQ3 integral fitting	Connection tubing O.D. ø4
R	Threaded	Rc 1/8
N	Threaded	NPT 1/8

#### Variations

Type	Symbol	Model	Orifice diameter					
			LVQ20H	LVQ30H	LVQ40H	LVQ50H	LVQ60H	
			ø4	ø8	ø10	ø16	ø22	
		Tubing outside dia.		Valve type				
		Millimeter		N.C.				
		Inch		N.O.				
		1/4		Double acting				
<b>Basic type</b>  N.C. N.O. Double acting	 B PA A B PA A B PA A N.C. N.O. Double acting	N.C.	○	○	○	○	○	
		N.O.	○	○	○	○	○	
		Double acting	○	○	○	○	○	
<b>With flow rate adjustment</b> 	 B PA A N.C.	N.C.	○	○	○	○	○	
<b>With bypass</b>  N.C.	 B PA A B PA A N.C. Double acting	N.C.	○	○	○	○	○	
		Double acting	○	○	○	○	○	
<b>With flow rate adjustment &amp; bypass</b> 	 B PA A N.C.	N.C.	○	○	○	○	○	
<b>With indicator</b> 	 B PA A N.C.	N.C.	○	○	○	○	○	
<b>With indicator &amp; bypass</b> 	 B PA A N.C.	N.C.	○	○	○	○	○	



### ⚠ Specific Product Precautions

Be sure to read before handling. Refer to front matters 42 and 43 for Safety Instructions, and pages 585 and 586 for High Purity Chemical Valve Non-Metallic Exterior Precautions.

### Piping

## ⚠ Caution

#### 1. Connect tubing with special tools.

Refer to the pamphlet “High-Purity Fluoropolymer Fittings HYPER FITTING®/Series LQ1, 2 Work Procedure Instructions” (M-E05-1) or “High Purity Fluoropolymer Fittings Hyper Fitting/Flare Type Series LQ3 Fitting Procedure” (M-E06-4A) for connecting tubing and special tools. (Downloadable from our web site.)

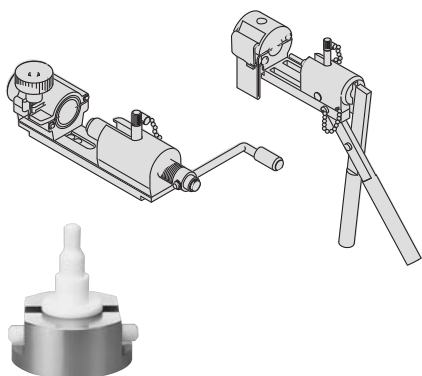

2. Tighten the nut to the end surface of the body. As a guide, refer to the proper tightening torques shown below.

#### Tightening torque for piping

Body class	Torque (N·m)		
	LQ1	LQ2	LQ3
2	0.3 to 0.4	1.5 to 2.0	1.6 to 1.8
3	0.8 to 1.0	3.0 to 3.5	3.2 to 3.5
4	1.0 to 1.2	7.5 to 9.0	5.0 to 5.3
5	2.5 to 3.0	11.0 to 13.0	10.0 to 10.5
6	5.5 to 6.0		22.5 to 23.0

## Standard Specifications

Model		LVQ20H	LVQ30H	LVQ40H	LVQ50H	LVQ60H
Tubing O.D.	Metric size	6	10	12	19	25
	Inch size	1/4	3/8	1/2	3/4	1
Orifice diameter		ø4	ø8	ø10	ø16	ø22
Flow characteristics	Av x 10 <sup>-6</sup> m <sup>2</sup>	8.4	31.2	45.6	120	192 (228) <sup>Note)</sup>
	Cv	0.35	1.3	1.9	5	8 (9.5) <sup>Note)</sup>
Withstand pressure (MPa)		1				
Operating pressure <A→B flow>		-98 kPa to 0.5 MPa				
Back pressure (MPa)		0.5 or less				
Valve leakage (cm <sup>3</sup> /min)		0 (With water pressure)				
Pilot air pressure (MPa)		0.5 to 0.8				
Pilot port size		1/8" (ø3), ø4, Rc 1/8, NPT 1/8				
Fluid temperature (°C)		0 to 100				
Ambient temperature (°C)		0 to 60				
Mass (kg)		0.08	0.17	0.22	0.70	0.81

Note) ( ) is high flow specification.

## Dimensions

Dimensions will be the same as the standard specifications.

## Different Diameter Tubing Applicable with Reducer (For LVQ□□H-V<sub>S</sub>)

Different diameter tubing can be selected (within a body class) by using a nut and insert bushing (reducer).

● With reducer

Body class	Tubing O.D.													
	Metric sizes							Inch sizes						
	4	6	8	10	12	19	25	1/8	3/16	1/4	3/8	1/2	3/4	1
2	●	○	—	—	—	—	—	●	●	○	—	—	—	—
3	—	●	●	○	—	—	—	—	—	●	○	—	—	—
4	—	—	—	●	○	—	—	—	—	—	●	○	—	—
5	—	—	—	—	●	○	—	—	—	—	—	●	○	—
6	—	—	—	—	—	●	○	—	—	—	—	—	●	○

⦿ Note) Refer to page 544 for information on changing tubing sizes.

LVC  
LVA  
LVH  
LVD  
LVQ  
LQ1  
LVN  
TL/TIL  
LQ3



# Applicable Fluids

## Material and fluid compatibility check list for air operated chemical valves

Chemical	Compatibility
Acetone	<input type="radio"/> Note 1, 2)
Ammonium hydroxide	<input type="radio"/> Note 2)
Isobutyl alcohol	<input type="radio"/> Note 1, 2)
Isopropyl alcohol	<input type="radio"/> Note 1, 2)
Hydrochloric acid	<input type="radio"/>
Ozone (dry)	<input type="radio"/>
Hydrogen peroxide Concentration 5% or less, 50°C or less	<input type="radio"/>
Ethyl acetate	<input type="radio"/> Note 1, 2)
Butyl acetate	<input type="radio"/> Note 1, 2)
Nitric acid (except fuming nitric acid) Concentration 10% or less	<input type="radio"/> Note 2)
DI water	<input type="radio"/>
Sodium hydroxide Concentration 50% or less	<input type="radio"/>
Nitrogen gas	<input type="radio"/>
Super pure water	<input type="radio"/>
Toluene	<input type="radio"/> Note 1, 2)
Hydrofluoric acid	<input type="radio"/> Note 2)
Sulfuric acid (except fuming sulfuric acid)	<input type="radio"/> Note 2)
Phosphoric acid Concentration 80% or less	<input type="radio"/>

Table symbols	<input type="radio"/> : Can be used
	<input type="radio"/> : Can be used in certain conditions
	× : Cannot be used



The material and fluid compatibility check list provides reference values as a guide only.

Note 1) Since static electricity may be generated, implement suitable countermeasures.

Note 2) Use caution as permeation may occur. The permeated fluid may effect the parts of other materials.

- Compatibility is indicated for fluid temperatures of 100°C or less.
- The material and fluid compatibility check list provides reference values as a guide only, therefore we do not guarantee the application to our product.
- The data above is based on the information presented by the material manufacturers.
- SMC is not responsible for its accuracy and any damage happened because of this data.



## Series LVQ

# High Purity Chemical Valve Non-Metallic Exterior Specific Product Precautions 1

Be sure to read before handling.

### Design & Selection

#### ⚠ Warning

##### 1. Confirm the specifications.

Give careful consideration to operating conditions such as the application, fluid and environment, and use within the operating ranges specified in this catalog.

##### 2. Fluids

Operate after confirming the compatibility of the product's component materials with fluids, using the check list on features page 584. Contact SMC regarding fluids other than those in the check list.

Operate within the indicated fluid temperature range.

##### 3. Maintenance space

Ensure the necessary space for maintenance and inspections.

##### 4. Fluid pressure range

Keep the supplied fluid pressure within the operating pressure range shown in the catalog.

##### 5. Ambient environment

Operate within the ambient operating temperature range. After confirming the compatibility of the product's component materials with the ambient environment, operate so that fluid does not adhere to the product's exterior surfaces.

##### 6. Liquid seals

When circulating fluid

Provide a relief valve in the system so that fluid does not get into the liquid seal circuit.

##### 7. Countermeasures for static electricity

Since static electricity may be generated depending on the fluid being used, implement suitable countermeasures.

### Mounting

#### ⚠ Warning

##### 1. If air leakage increases or equipment does not operate properly, stop operation.

After mounting, perform suitable function and leak tests to confirm that the mounting is correct.

##### 2. Instruction manual

Mount and operate the product after reading the manual carefully and understanding its contents. Also keep the manual where it can be referred to as necessary.

### Piping

#### ⚠ Caution

##### 1. Preparation before piping

Before piping is connected, it should be thoroughly blown out with air (flushing) or washed to remove chips, cutting oil and other debris from inside the pipe.

Install piping so that it does not apply pulling, pressing, bending or other forces on the valve body.

##### 2. Use the tightening torques shown below for the threaded pilot port.

###### Operating port tightening torque

Operating port	Torque (N·m)
Rc, NPT 1/8	0.8 to 1.0

##### 3. Use of metal fittings

In the case of threaded pilot port, do not pipe the metallic fittings which can cause damage to the thread part.

##### 4. Refer to the pamphlet "High-Purity Fluoropolymer Fittings HYPER FITTING®/Series LQ1, 2 Work Procedure Instructions" (M-E05-1) or "High Purity Fluoro polymer Fittings Hyper Fitting/Flare Type Series LQ3 Fitting Procedure" (M-E06-4) for connecting tubing and special tools. (Downloadable from our web site.)

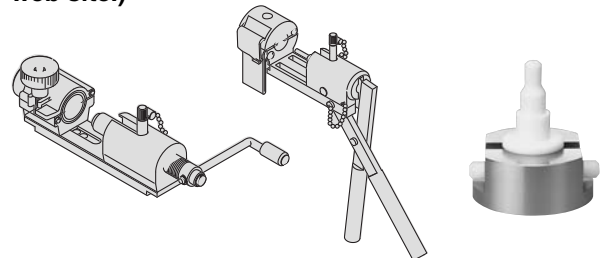

### Operating Air Supply

#### ⚠ Warning

##### 1. Use clean air.

Do not use compressed air which includes chemicals, synthetic oils containing organic solvents, salt, or corrosive gases, etc., as this may cause damage or malfunction.

LVC

LVA

LVH

LVD

LVQ

LQ1

LVN

TL/TIL

LQ3



## Series LVQ

# High Purity Chemical Valve Non-Metallic Exterior Specific Product Precautions 2

Be sure to read before handling.

### Operating Environment

#### Warning

1. Do not use in a location having an explosive atmosphere.
2. Do not operate in locations where vibration or impact occurs.
3. Do not use in locations where radiated heat will be received from nearby heat sources.

### Maintenance

#### Warning

1. Maintenance should be performed in accordance with the procedures in the instruction manual.  
Incorrect handling can cause damage or malfunction of machinery and equipment, etc.
2. Before removing equipment or compressed air supply/exhaust devices, shut off the air and power supplies, and exhaust compressed air from the system. Further, when restarting equipment after remounting or replacement, first confirm safety and then check the equipment for normal operation.
3. Perform work after removing residual chemicals and carefully replacing them with DI water or air, etc.
4. Do not disassemble the product. Products which have been disassembled cannot be guaranteed.  
If disassembly is necessary, contact SMC.
5. In order to obtain optimum performance from valves, perform periodic inspections to confirm that there are no leaks from valves or fittings, etc.

#### Caution

1. Removal of drainage  
Flush drainage from filters regularly.

### Precautions on Usage

#### Warning

1. Operate within the ranges of the maximum operating pressure and back pressure.

#### Caution

1. Please note that when the product is shipped from the factory, gases such as N<sub>2</sub> and air may leak from the valve at a rate of 1cm<sup>3</sup>/min (when pressurized).
2. When operated at a very low flow rate, the series LVQ with flow rate adjustment may vibrate, etc. depending on the operating conditions. Therefore, operate it after careful examination of the flow rate, pressure and piping conditions.
3. In the series LVQ, water hammering may occur depending on the fluid pressure conditions. In most cases, improvement is possible by adjusting the pilot pressure with a speed controller, etc., but the flow rate, pressure and piping conditions should be reviewed.
4. To adjust the flow rate for the series LVQ with flow rate adjustment, open gradually starting from the fully closed condition.  
Opening is accomplished by turning the adjustment knob counter clockwise.  
Additionally, do not apply any unreasonable force to the adjustment knob when nearing a fully opened or closed state. This may result in deformation of the orifice sheet surface or damage to the threaded part of the adjustment knob.  
It is in the fully closed condition when the product is shipped from the factory.
5. After a long period of nonuse, perform a test run before beginning regular operation.
6. Since the LVQ is packaged in a clean room use sufficient care in handling when opened.