

Series HYG

ø20, ø25, ø32
ø40, ø50, ø63

Replacement
Procedure is
P.301

Construction

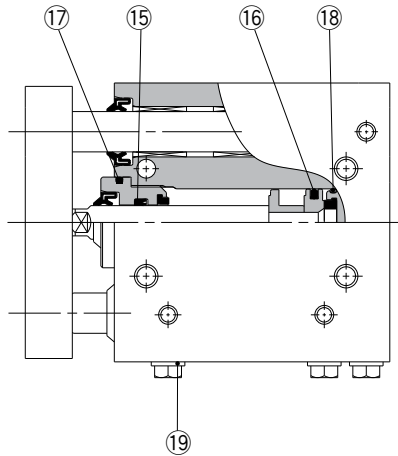

* The numbers are the same as the "Construction" of the Best Pneumatics No.2 Series HYG.

Seal Kit List

No.	Description	Material	Note
15	Rod seal	NBR	(FKM can be selected.)
16	Piston seal	NBR	
17	O-ring (Rod end)	NBR	(FKM can be selected.)
18	O-ring (Head end)	NBR	
19	Seal washer	Stainless steel + NBR	(FKM can be selected.)

18 is a non-replaceable part, so it is not included in the seal kit.

*[BLUE](#) links will lead to purchase pages.

Replacement Parts: Seal Kit NBR

Bore size (mm)	Kit no.	Contents
20	HYG20R-PS	Set of left nos. 15, 16, 17, 19.
25	HYG25R-PS	
32	HYG32R-PS	

Replacement Parts: Seal Kit External FKM

Bore size (mm)	Kit no.	Contents
20	HYG20H-PS	Set of left nos. 15, 16, 17, 19.
25	HYG25H-PS	
32	HYG32H-PS	

Place the seal material symbol in □.

Symbol	Material
R	NBR
H	External FKM*

* External seal: Rod seal, O-ring (Rod side) and seal washer are made from FKM.

* Seal kit includes 15, 16, 17 and 19. Order the seal kit based on each bore size.

* Since the seal kit does not include a grease pack, order it separately.
Grease for food part no.: GR-H-010 (10 g)
Standard grease part no.: GR-S-010 (10 g)

⚠ Caution

Please contact SMC to repair or replace seals of cylinder bore size 40 mm and above.

Please contact SMC when the cylinder has to be disassembled for the purpose of replacing seals, etc.

Actuators

Modular F.R.L.
Pressure Control Equipment

Air Preparation
Equipment

Industrial Filters

Replacement
Procedure

Actuators

Modular F.R.L.
Pressure Control Equipment

Industrial Filters