

# Series REAS

ø10, ø15

Replacement  
Procedure is  
P.361

## Construction

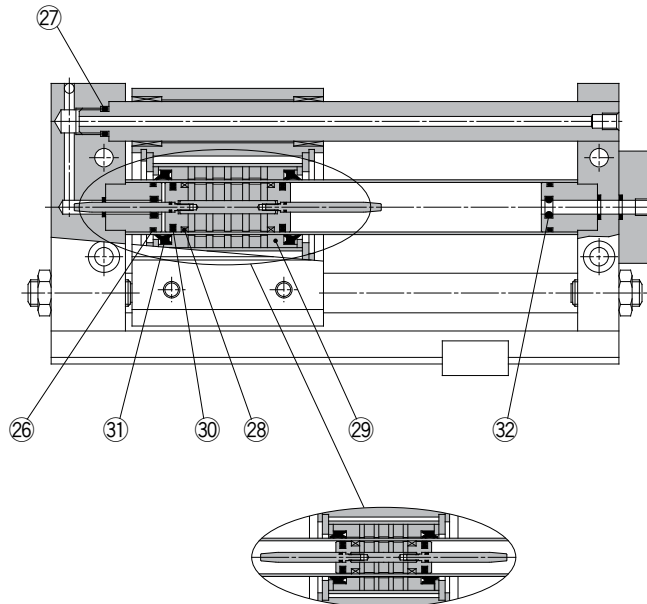

REAS10

\* The numbers are the same as the "Construction" of the Best Pneumatics No.3 Series REAS.

### Seal Kit List

No.	Description	Material	Note
26	Cylinder tube gasket	NBR	
27	Guide shaft gasket	NBR	
28	Wear ring A	Special resin	ø10: Not available
29	Wear ring B	Special resin	
30	Piston seal	NBR	
31	Scraper	NBR	
32	Cushion seal	NBR	

\* Seal kit includes 26 to 32. Order the seal kit, based on each bore size.

\*[BLUE](#) links will lead to purchase pages.

### Replacement Parts: Seal Kit

Bore size (mm)	Kit no.	Contents
10	<a href="#">REAS10-PS</a>	Set of left nos. 26, 27, 29, 30, 31, 32 <small>Note)</small>
15	<a href="#">REAS15-PS</a>	Set of left nos. 26, 27, 28, 29, 30, 31, 32 <small>Note)</small>

Note) It may be difficult to replace the cushion seal 32.

Note) For wear ring A of ø10, please consult with SMC.

\* Seal kit includes a grease pack (ø10: 5 g and 10 g, ø15: 10 g).

Order with the following part number when only the grease pack is needed.

For ø10 grease pack part no.: GR-F-005 (5 g) for external sliding part  
GR-S-010 (10 g) for tube interior

For ø15 grease pack part no.: GR-S-010 (10 g)

# Sine Rodless Cylinder/Slider Type: Slide Bearing

## Series REAS

ø20, ø25, ø32, ø40

Replacement  
Procedure is  
P.361

### Construction

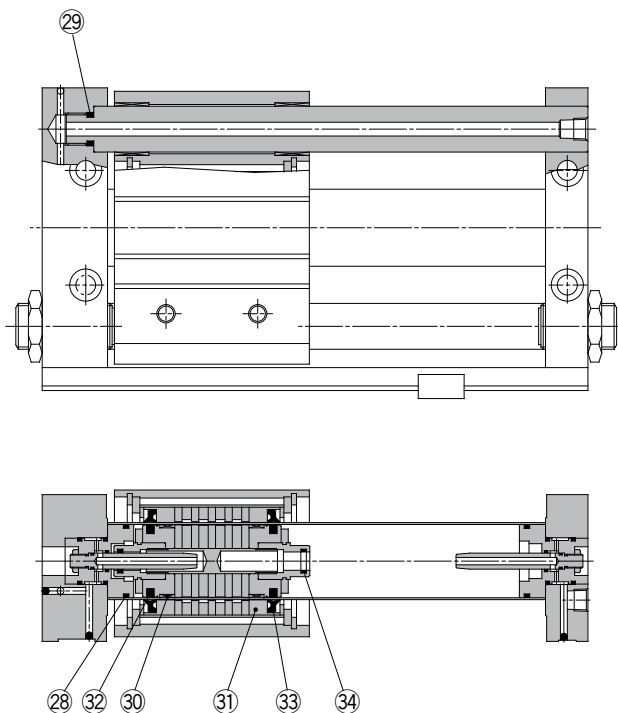

\* The numbers are the same as the "Construction" of the Best Pneumatics No.3 Series REAS.

#### Seal Kit List

No.	Description	Material	Note
28	Cylinder tube gasket	NBR	
29	Guide shaft gasket	NBR	
30	Wear ring A	Special resin	
31	Wear ring B	Special resin	
32	Piston seal	NBR	
33	Scraper	NBR	
34	Cushion seal	NBR	

\* Seal kit includes 28 to 34. Order the seal kit, based on each bore size.

\*[BLUE](#) links will lead to purchase pages.

#### Replacement Parts: Seal Kit

Bore size (mm)	Kit no.	Contents
20	<a href="#">REAS20-PS</a>	Set of left nos. 28, 29, 30, 31, 32, 33, 34 <sup>Note)</sup>
25	<a href="#">REAS25-PS</a>	
32	<a href="#">REAS32-PS</a>	
40	<a href="#">REAS40-PS</a>	

Note) Cushion seal 34 may be difficult to be replaced.

\* Seal kit includes a grease pack (10 g).

Order with the following part number when only the grease pack is needed.

**Grease pack part no.:** GR-S-010 (10 g)

Actuators

Modular F.R.L.  
Pressure Control Equipment

Air Preparation  
Equipment

Industrial Filters

Replacement  
Procedure

Actuators

Modular F.R.L.  
Pressure Control Equipment

Industrial Filters