

Series CVS1K

Non-lube Type:
ø40, ø50, ø63

Construction

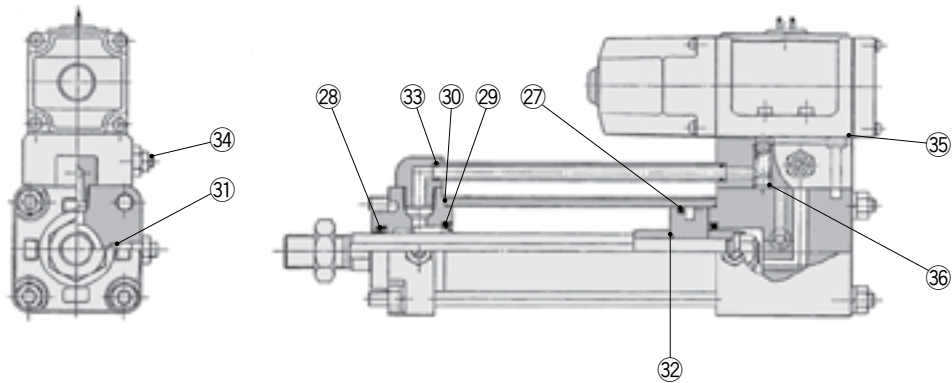

* The numbers are the same as the "Construction" of the Best Pneumatics No.3 Series CVS1K.

*[BLUE](#) links will lead to purchase pages.

Seal Kit List

No.	Description	Material	Note
27	Piston seal	NBR	29, 32, 34 and 35 are non-replaceable parts, so they are not included in the seal kit.
28	Rod seal		
29	Cushion seal		
30	Cylinder tube gasket		
31	Cushion valve seal		
32	Piston gasket		
33	Pipe gasket		
34	Speed adjustment valve seal		
35	Gasket		
36	Valve port gasket		

Replacement Parts: Seal Kit

Bore size (mm)	Kit no.	Contents
40	CVS1K40-PS	Set of left nos. 27, 28, 30, 31, 33, 36
50	CVS1K50-PS	
63	CVS1K63-PS	

* Seal kit includes 27, 28, 30, 31, 33, 36. Order the seal kit, based on each bore size.

* Seal kit includes a grease pack (ø40, ø50: 10 g, ø63 or more: 20 g). Order with the following part number when only the grease pack is needed.

Grease pack part no.: GR-S-010 (10 g), GR-S-020 (20 g)

Disassembly/Replacement

1. Please consult with SMC when the rod seal is to be replaced.

When the rod seal is to be replaced, make sure that the seal's width across flats matches that of the non-rotating guide.

A rod seal may allow air leakage depending on the position where it is installed. Therefore, please consult with SMC when a rod seal is to be replaced.

2. Do not replace the non-rotating guide.

Since the non-rotating guide is press fitted, the entire cover assembly needs to be replaced instead of a single part.