

Modular F.R.L. Pressure Control Equipment

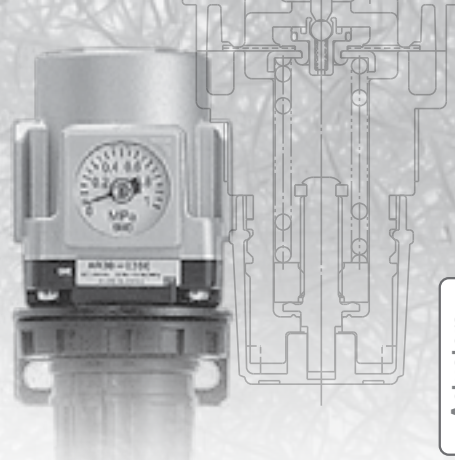
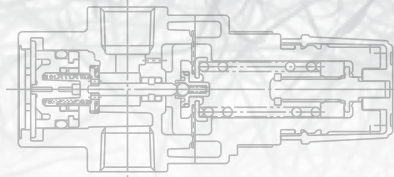

1 Indication of replacement of elements, inspection items P.216

2 Troubleshooting P.217

3 Details of replacement parts

AF10 to AF60	Air Filter	P.220
AFM20 to AFM40	Mist Separator	P.221
AFD20 to AFD40	Micro Mist Separator	P.221
AR10 to AR60	Regulator	P.222
AR20K to AR60K	Regulator with Backflow Function	P.222
AL10 to AL60	Lubricator	P.223
AW10 to AW60	Filter Regulators	P.224
AW20K to AW60K	Filter Regulator with Backflow Function	P.224
AWM20 to AWM40	Mist Separator Regulator	P.225
AWD20 to AWD40	Micro Mist Separator Regulator	P.225
AC, ACG	Air Combination	P.226
ARG20(K)/30(K)/40(K)	Regulator with Built-in Pressure Gauge	P.228
AWG20/30/40	Filter Regulator with Built-in Pressure Gauge	P.229
AWG20K/30K/40K	Filter Regulator with Built-in Pressure Gauge with Backflow Function	P.230
AR425 to 935	Pilot Operated Regulator	P.231
AMR3000 to 6000	MR Unit (Regulator with Mist Separator)	P.232
ARM5A	Compact Manifold Regulator/Centralized Supply Type	P.233
ARM5B	Compact Manifold Regulator/Individual Supply Type	P.234
ARM5S	Regulator/Single Unit Type	P.235
ARM10	Regulator/Single Unit Type	P.236
ARM11A	Compact Manifold Regulator/Common Supply Type	P.237
ARM11B	Compact Manifold Regulator/Individual Supply Type	P.238
ARM11A/B	Compact Manifold Regulator/Options	P.239

Actuators

Modular F.R.L.
Pressure Control Equipment

Air Preparation
Equipment

Industrial Filters

Replacement
Procedure

Actuators

Modular F.R.L.
Pressure Control Equipment

Industrial Filters

Modular F.R.L. Pressure Control Equipment

1 Indication of replacement of elements, inspection items

The following describes the general contents of the element replacement and regular check.

Indication of replacement of air filter, inspection items

■ Replacement standards

<Element replacement>

The differential pressure (pressure drop) between the primary side and secondary side reaches 0.1 MPa. Even when any pressure differential does not occur, replace the element every two years.

■ Inspection items

1) Checking of external leak or case crack.

If the case is cracked, this may lead to a serious accident, such as case rupture. So, replace the case immediately and locate the cause. If the case is contaminated significantly and the internal status cannot be checked, clean the case with neutral detergent. At this time, never use solvent or machine cleaning solution.

2) Functional inspection of drain discharge mechanism

Check that the drain mechanism functions correctly without fail and that the drain is discharged periodically for manual type.

If the drain is produced excessively, a trouble may occur in the purification equipment on the upstream side.

■ Probable troubles (Reference)

Refer to the "Troubleshooting" for air filter/auto drain. (P.217)

Regulator inspection items

■ Inspection items

Check the set pressure level before starting up the equipment. If the set pressure level is beyond the specified range, locate the cause.

(Be sure to locate the cause before starting the readjustment.) Additionally, check the following points during periodic inspection.

1) Functional inspection and grease-up of the valve body (including the valve guide)

2) Functional inspection and grease-up of the valve spring

Check for rust, breakage, or permanent settling.

3) Checking of setting function and relief function (Check the functions by increasing or decreasing the setting.)

■ Probable troubles (Reference)

Refer to the "Troubleshooting" for regulator. (P.218)

Lubricator inspection items

■ Inspection items

① Inspection of dripping volume: Inspect this item when starting the equipment operation.

② Check the oil status inside the case. Check for drain entry.

③ Check for air leak inside the case or air backflow on the secondary side.

■ Probable troubles (Reference)

Refer to the "Troubleshooting" for lubricator. (P.219)

2 Troubleshooting

The following describes the general contents of the troubleshooting.

[Air filter/Auto drain]

Trouble (Symptom)	Cause	Corrective action
The pressure drop is large and the specified flow rate cannot be obtained.	1. The element is clogged.	1. Replace the element.
The air leaks from the portion between the bowl and body.	1. The bowl O-ring is damaged.	1. Replace the bowl O-ring. Apply the grease to the bowl O-ring, and then assemble it into the bowl.
The air leaks from the bowl.	1. The bowl is damaged.	1. Replace the bowl assembly or replace the bowl with a metallic bowl.
The air leaks from the drain cock.	1. A foreign object is caught in the valve of the drain cock.	1. Open the drain cock for several seconds to blow out the foreign object.
	2. The drain cock seat is damaged.	2. Replace the bowl assembly.
The drain is not discharged even when the drain cock is opened.	1. The discharge port of the drain cock is clogged with solid foreign object.	1. Replace the bowl assembly.
An excessive amount of drain is discharged to the pipe at the outlet.	1. The drain level exceeds the baffle.	1. Open the drain cock to discharge the drain, and then replace the element.

Modular F.R.L. Pressure Control Equipment

2 Troubleshooting

The following describes the general contents of the troubleshooting.

[Regulator]

Trouble (Symptom)	Cause	Corrective action
The pressure cannot be regulated.	1. The regulator is installed in a direction opposite to the flow direction.	1. Check the flow direction. If the installation direction is opposite to the flow direction, reinstall the regulator.
	2. The spring is broken.	2. Replace the spring.
	3. The valve spring is broken.	3. Replace the valve spring.
	4. A foreign object is caught in the valve seat or valve O-ring.	4. Remove the valve guide, and then clean the valve, valve seat, and valve O-ring. At this time, apply the grease to the valve O-ring and sliding part after cleaning.
	5. The rubber lining surface of the valve is damaged.	5. Replace the valve.
	6. A foreign object is caught in the check valve seat. (AR20K to AR60K)	6. Replace the check valve assembly.
The set pressure level does not become zero (0) even when the handle is loosened.	1. A foreign object is caught in the valve seat or valve O-ring.	1. Remove the valve guide, and then clean the valve, valve seat, and valve O-ring. At this time, apply the grease to the valve O-ring and sliding part after cleaning.
	2. The rubber seat surface of the valve is damaged.	2. Replace the valve.
	3. The valve spring is broken.	3. Replace the valve spring.
	4. The valve is locked.	4. Clean the sliding surface of the valve O-ring and apply the grease.
	5. A foreign object is caught in the check valve seat. (AR20K to AR60K)	5. Replace the check valve assembly.
The air leaks from the exhaust port in the bonnet.	1. The diaphragm is damaged.	1. Replace the diaphragm assembly.
	2. The piston seal is damaged.	2. Replace the piston assembly or clean it. At this time, apply the grease to the piston seal and sliding surface.
	3. A foreign object is caught in the exhaust valve seat.	3. Clean the exhaust valve seat or replace the diaphragm assembly.
	4. A foreign object is caught in the valve seat or valve O-ring.	4. Remove the valve guide, and then clean the valve, valve seat, and valve O-ring. At this time, apply the grease to the valve O-ring and sliding part after cleaning.
	5. The rubber sheet surface of the valve is damaged.	5. Replace the valve.
	6. The back pressure exceeding the set pressure level is applied to the secondary side.	6. Review the air circuit so that the back pressure exceeding the set pressure level is not applied.
	7. A foreign object is caught in the check valve seat. (AR20K to AR60K)	7. Replace the check valve assembly.

[Regulator]

Trouble (Symptom)	Cause	Corrective action
The air leaks from the portion between the bonnet and body.	1. The bonnet screw is loose.	1. Retighten the bonnet screw.
	2. The diaphragm is damaged.	2. Replace the diaphragm assembly.
The air does not flow backward.	1. A foreign object is caught in the sliding part of the check valve, causing malfunction. (AR20K to AR60K)	1. Replace the check valve assembly.
	2. The check valve is locked. (AR20K to AR60K)	2. Replace the check valve assembly.

[Lubricator]

Trouble (Symptom)	Cause	Corrective action
The oil does not drop even when the air flows.	1. The equipment is not connected correctly.	1. Check the "IN", "OUT", and arrow marks on the equipment. If any incorrect connection is found, connect the equipment again.
	2. The oil volume inside the bowl is insufficient.	2. Supply the oil.
	3. The air consumption flow rate is insufficient.	3. Select an appropriate lubricator with a minimum dripping flow rate suitable for the flow rate to be used.
	4. The damper is damaged.	4. Replace the damper (assembly).
	5. The oil adjustment valve is closed.	5. Open the oil adjustment valve.
	6. The air leaks from the bowl or lubrication plug.	6. Replace the case O-ring or lubrication plug assembly.
	7. The element is clogged.	7. Replace the damper pushing air assembly.
	8. The air leaks from the sight dome.	8. Replace the sight dome assembly.
Air bubbles are mixed in the oil drop.	1. The oil passage pipe seal is damaged.	1. Replace the damper retainer air assembly.
	2. The oil volume inside the bowl is insufficient.	2. Supply the oil.
The air or oil leaks from the sight glass.	1. The sight dome is damaged.	1. Replace the sight dome assembly.
	2. The O-ring is damaged.	2. Replace the sight dome assembly.
The air leaks from the lubrication plug.	1. The O-ring is damaged.	1. Replace the lubrication plug assembly.
The air leaks from the portion between the bowl and body.	1. The bowl O-ring is damaged.	1. Replace the bowl O-ring. Apply the grease to the bowl O-ring and assemble it into the bowl.
The air leaks from the bowl	1. The bowl is damaged.	1. Replace the bowl assembly or replace the bowl with a metallic bowl.

AF10 to AF60



Construction

AF10, AF20

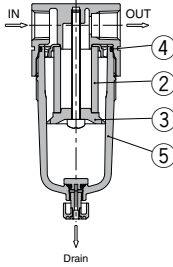

AF30 to AF40-06

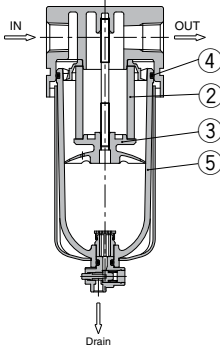

AF50, AF60

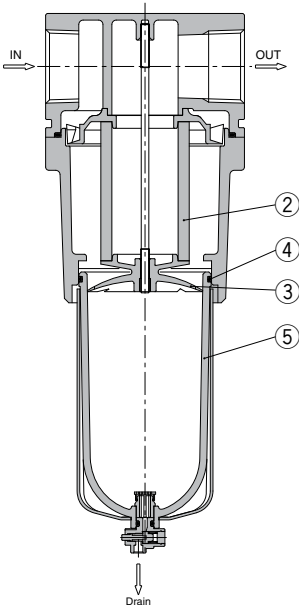

*[BLUE](#) links will lead to purchase pages.

Replacement Parts

No.	Description	Material	Part no.					
			AF10	AF20	AF30	AF40	AF40-06	AF50
②	Filter element	Non-woven fabric	AF10P-060S	AF20P-060S	AF30P-060S	AF40P-060S	AF50P-060S	AF60P-060S
③	Baffle	PBT	AF10P-040S	AF20P-040S	AF30P-040S	AF40P-040S	AF50P-040S	AF60P-040S
④	Bowl O-ring	NBR	C1SFP-260S	C2SFP-260S	C3SFP-260S	CXSJL6-PS		
⑤	Bowl assembly	Polycarbonate	C1SF	C2SF	C3SF	CXSJL6-PS		

Note 1) The material of the baffle for the AF10 (AF10P-040S) only is polycetal.

Note 2) Bowl O-ring is included.

Please contact SMC regarding the bowl assembly supply for psi and °F unit specifications.

Note 3) Bowl assembly for the AF30 to AF60 models comes with a bowl guard (steel band material).

Options/Part No.

Optional specifications	Model						
	AF10	AF20	AF30	AF40	AF40-06	AF50	AF60
Bracket assembly ^{Note 1)}	—	AF20P-050AS	AF30P-050AS	AF40P-050AS	AF40P-070AS	AF50P-050AS	AF60P-050AS
Float type auto drain ^{Note 2) Note 3)}	N.C.	AD17	AD27	AD37	AD47		
	N.O.	—	AD38	AD48			

Semi-standard/Bowl Assembly Part No.

Semi-standard specifications					Model						
Bowl material	^{Note 2) Note 3)} Float type auto drain	^{Note 3)} With drain guide	With barb fitting	With bowl guard	AF10	AF20	AF30	AF40	AF40-06	AF50	AF60
	N.C.	N.O.									
Polycarbonate	—	—	—	●	—	C2SF-C	—	—	—	—	—
	●	—	—	—	—	AD27-C	—	—	—	—	—
	—	—	●	—	—	C2SF-J	C3SF-J	C4SF-J		—	—
	—	—	—	●	—	—	C3SF-W	C4SF-W		—	—
Nylon	—	—	—	●	—	C2SF-CJ	—	—	—	—	—
	—	—	—	—	—	C1SF-6	C2SF-6	C3SF-6	C4SF-6		—
	—	—	—	—	—	—	C2SF-6G	—	—	—	—
	●	—	—	—	—	AD17-6	AD27-6	AD37-6	AD47-6		—
	—	●	—	—	—	—	AD38-6	AD48-6		—	—
	●	—	—	—	●	—	AD27-6C	—	—	—	—
Metal	—	—	—	—	—	C2SF-6J	C3SF-6J	C4SF-6J		—	—
	—	—	—	●	—	—	C3SF-6W	C4SF-6W		—	—
	—	—	●	—	—	C2SF-6CJ	—	—	—	—	—
	—	—	—	—	—	C1SF-2	C2SF-2	C3SF-2	C4SF-2		—
Metal bowl with level gauge	●	—	—	—	—	AD17-2	AD27-2	AD37-2	AD47-2		—
	—	—	—	—	—	—	AD38-2	AD48-2		—	—
	—	—	●	—	—	—	C2SF-2J	C3SF-2J	C4SF-2J		—
Metal bowl with level gauge	—	—	—	—	—	—	C3LF-8	C4LF-8		—	—
	●	—	—	—	—	—	AD37-8	AD47-8		—	—
	—	●	—	—	—	—	AD38-8	AD48-8		—	—
	—	—	●	—	—	—	C3LF-8J	C4LF-8J		—	—

Note 1) Assembly of a bracket and 2 mounting screws

Note 2) Minimum operating pressure: N.O. type—0.1 MPa; N.C. type—0.1 MPa (AD17/27) and 0.15 MPa (AD37/47). Please contact SMC for psi and °F unit specifications.

Note 3) Please consult with SMC for details on drain piping to fit NPT or G port sizes.

Note) • Bowl O-ring is included for the AF20 to AF60.

• Bowl assembly for the AF30 to AF60 models comes with a bowl guard (steel band material). (except when the bowl material is metal)

Mist Separator / Micro Mist Separator

AFM20 to AFM40 / AFD20 to AFD40

Replacement Procedure is P.402

Construction

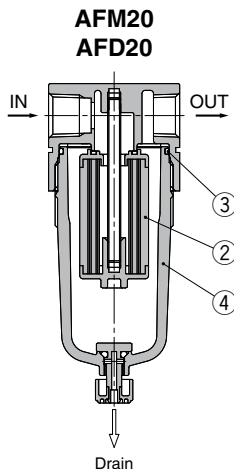

AFM30 to AFM40-06 / AFD30 to AFD40-06

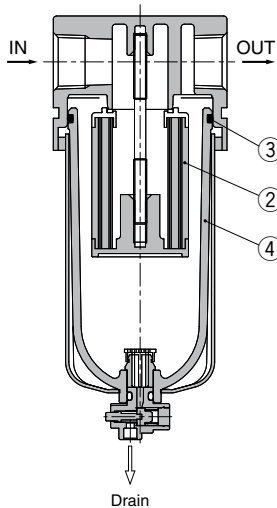

*[BLUE](#) links will lead to purchase pages.

Replacement Parts

No.	Description	Material	Part no.			
			AFM20 AFD20	AFM30 AFD30	AFM40 AFD40	AFM40-06 AFD40-06
②	Element assembly	AFM20 to 40 AFD20 to 40	AFM20P-060AS AFD20P-060AS	AFM30P-060AS AFD30P-060AS	AFM40P-060AS AFD40P-060AS	
③	Bowl O-ring	NBR	C2SFP-260S	C3SFP-260S	C4SFP-260S	
④	Bowl assembly	Polycarbonate	C2SF	C3SF	C4SF	

Note 1) Bowl O-ring is included.

Please contact SMC regarding the bowl assembly supply for psi and °F unit specifications.

Note 2) Bowl assembly for the AFM30 to AFM40-06 models and the AFD30 to AFD40-06 models comes with a bowl guard (steel band material).

Options/Part No.

Optional specifications	Model			
	AFM20 AFD20	AFM30 AFD30	AFM40 AFD40	AFM40-06 AFD40-06
Bracket assembly	AF20P-050AS	AF30P-050AS	AF40P-050AS	AF40P-070AS
Float type auto drain	N.C.	AD27	AD37	AD47
	N.O.	—	AD38	AD48

Semi-standard/Bowl Assembly Part No.

Semi-standard specifications						Model			
Bowl material	Note 2) Note 3) Float type auto drain	Note 3) With drain guide	Note 3) With barb fitting	Note 3) With bowl guard		AFM20 AFD20	AFM30 AFD30	AFM40 AFD40	AFM40-06 AFD40-06
Polycarbonate	—	—	—	●		C2SF-C	—	—	—
	●	—	—	—	●	AD27-C	—	—	—
	—	—	●	—	—	C2SF-J	C3SF-J	—	C4SF-J
	—	—	—	●	—	—	C3SF-W	—	C4SF-W
Nylon	—	—	—	●		C2SF-CJ	—	—	—
	—	—	—	—	—	C2SF-6	C3SF-6	—	C4SF-6
	—	—	—	—	●	C2SF-6C	—	—	—
	●	—	—	—	—	AD27-6	AD37-6	—	AD47-6
Metal	●	—	—	—	—	—	AD38-6	—	AD48-6
	—	—	—	—	—	C2SF-6J	C3SF-6J	—	C4SF-6J
	—	—	—	●	—	—	C3SF-6W	—	C4SF-6W
	—	—	●	—	●	C2SF-6CJ	—	—	—
Metal bowl with level gauge	—	—	—	—	—	C2SF-2	C3SF-2	—	C4SF-2
	●	—	—	—	—	AD27-2	AD37-2	—	AD47-2
	—	●	—	—	—	—	AD38-2	—	AD48-2
	—	—	●	—	—	C2SF-2J	C3SF-2J	—	C4SF-2J
Metal bowl with level gauge	—	—	—	—	—	—	C3LF-8	—	C4LF-8
	●	—	—	—	—	—	AD37-8	—	AD47-8
	—	●	—	—	—	—	AD38-8	—	AD48-8
	—	—	●	—	—	C3LF-8J	—	C4LF-8J	

Note 1) Assembly of a bracket and 2 mounting screws

Note 2) Minimum operating pressure: N.O. type—0.1 MPa; N.C. type—0.1 MPa (AD27) and 0.15 MPa (AD37/47). Please consult with SMC separately for psi and °F unit display specifications.

Note 3) Please consult with SMC for details on drain piping to fit NPT or G port sizes.

Note) • Bowl O-ring is included.

• Bowl assembly for the AFM30 to AFM40-06 models and AFD30 to AFD40-06 models comes with a bowl guard (steel band material). (except when the bowl material is metal)

Regulator Regulator with Backflow Function

AR10 to AR60 / AR20K to AR60K

Replacement
Procedure is
P. 404

Construction

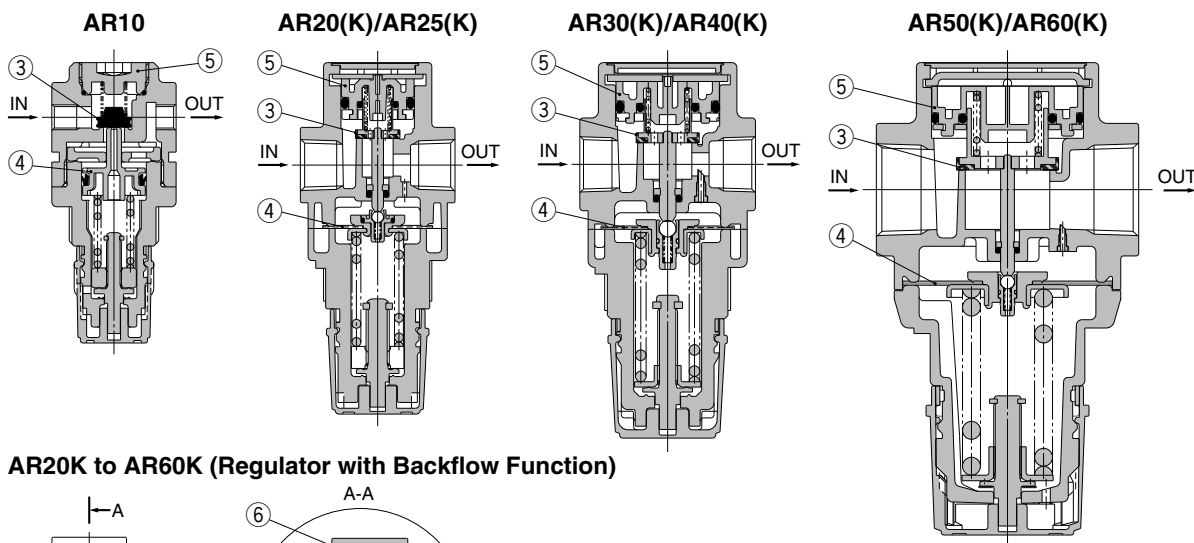

AR20K to AR60K (Regulator with Backflow Function)

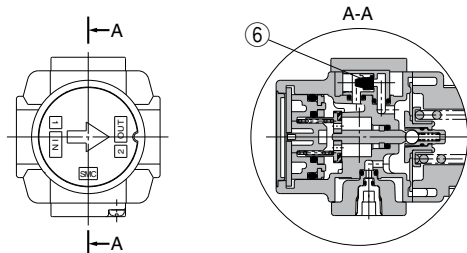

* The numbers are the same as the "Construction" of the Best Pneumatics No.5 Series AR.

* **BLUE** links will lead to purchase pages.

Replacement Parts

No.	Description	Material	Part no.							
			AR10	AR20(K)	AR25(K)	AR30(K)	AR40(K)	AR40(K)-06	AR50(K)	AR60(K)
③	Valve assembly	Brass, HNBR	AR10P-090S	AR20P-410S	AR25P-410S	AR30P-410S	AR40P-410S	AR40P-410S	AR50P-410S	AR60P-410S
④	Diaphragm assembly	Weather resistant, NBR	AR10P-150AS	AR20P-150AS	AR25P-150AS	AR30P-150AS	AR40P-150AS	AR40P-150AS	AR50P-150AS	AR60P-150AS
⑤	Valve guide assembly	Polyacetal	131329	AR20P-050AS	AR25P-050AS	AR30P-050AS	AR40P-050AS	AR40P-050AS	AR50P-050AS	AR60P-050AS
⑥	Check valve assembly ^{Note 2)}	—	—	—	—	—	AR20KP-020AS	—	—	—

Note 1) The AR10 is a piston type. Assembly of a piston and a seal (KSYP-13).

Note 2) Check valve assembly is applicable for a regulator with backflow function (AR20K to AR60K) only.

Assembly of a check valve cover, check valve body assembly and 2 screws

Options/Part No.

Option		Model	AR10	AR20(K)	AR25(K)	AR30(K)	AR40(K)	AR40(K)-06	AR50(K)	AR60(K)
Bracket assembly ^{Note 1)}			AR10P-270AS	AR20P-270AS	AR25P-270AS	AR30P-270AS	AR40P-270AS	AR40P-270AS	AR50P-270AS	
Set nut			AR10P-260S	AR20P-260S	AR25P-260S	AR30P-260S	AR40P-260S	AR40P-260S	— ^{Note 3)}	— ^{Note 3)}
Pressure gauge	Round type ^{Note 4)}	Standard	G27-10-R1		G36-10-□01				G46-10-□02	
		0.02 to 0.2 MPa setting	G27-10-R1		G36-2-□01				G46-2-□02	
	Round type (with color zone) ^{Note 4)}	Standard	—		G36-10-□01-L				G46-10-□02-L	
		0.02 to 0.2 MPa setting	—		G36-2-□01-L				G46-2-□02-L	
Square embedded type ^{Note 6)}	Standard	—			GC3-10AS [GC3P-010AS (Pressure gauge cover only)]					
	0.02 to 0.2 MPa setting	—			GC3-2AS [GC3P-010AS (Pressure gauge cover only)]					
Digital pressure switch	NPN output: Wiring bottom entry	—			ISE35-N-25-MLA [ISE35-N-25-M (Switch body only)] ^{Note 7)}					
	NPN output: Wiring top entry	—			ISE35-R-25-MLA [ISE35-R-25-M (Switch body only)] ^{Note 7)}					
	PNP output: Wiring bottom entry	—			ISE35-N-65-MLA [ISE35-N-65-M (Switch body only)] ^{Note 7)}					
	PNP output: Wiring top entry	—			ISE35-R-65-MLA [ISE35-R-65-M (Switch body only)] ^{Note 7)}					

Note 1) Assembly of a bracket and set nuts

Note 2) Assembly of a bracket and 2 mounting screws

Note 3) Please consult with SMC regarding the set nuts for the AR50(K) and AR60(K).

Note 4) □ in part numbers for a round pressure gauge indicates a type of connection thread. No indication is necessary for R; however, indicate N for NPT.

Please contact SMC regarding the connection thread NPT and pressure gauge supply for psi unit specifications.

Note 5) Pressure gauge for general purpose

Note 6) Including one O-ring and 2 mounting screws. []: Pressure gauge cover only

Note 7) Lead wire with connector (2 m), adapter, lock pin, O-ring (1 pc.), mounting screw (2 pcs.) are attached. []: Switch body only

Also, regarding how to order the digital pressure switch, please refer to the Best Pneumatics No.5.

AL10 to AL60

Replacement Procedure is P.412

Construction

AL10

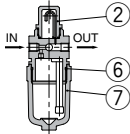

AL20

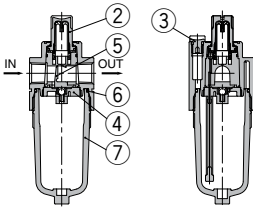

AL30/AL40

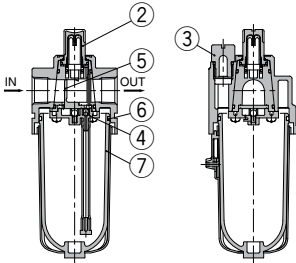

AL50/AL60

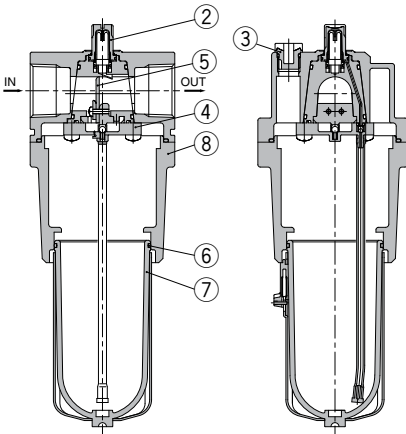

*[BLUE](#) links will lead to purchase pages.

Replacement Parts

No.	Description	Material	Part no.						
			AL10	AL20	AL30	AL40	AL40-06	AL50	AL60
②	Sight dome assembly	Polycarbonate	AL10P-080AS			AL20P-080AS			
③	Lubrication plug assembly	—	—	AL20P-060AS	AL30P-060AS	AL40P-060AS			
④	Damper retainer assembly ^{Note 1)}	—	—	AL20P-030AS	AL30P-030AS	AL40P-030AS	AL50P-030AS	AL60P-030AS	
⑤	Damper (assembly)	Synthetic resin	—	AL20P-040S	AL30P-040S	AL40P-040AS	AL50P-040AS	AL60P-040AS	
⑥	Bowl O-ring	NBR	C1SFP-260S	C2SFP-260S	C3SFP-260S	C4SFP-260S			
⑦	Bowl assembly ^{Note 2)}	Polycarbonate	C1SL	C2SL	C3SL	C4SL ^{Note 3)}			

Note 1) Add "1" at the end of the part number when ordering a damper retainer assembly for 1000 cm³.
Example) AL30P-030AS-1

Note 2) Bowl O-ring is included for the AL20 to AL60. Please contact SMC regarding the bowl assembly supply for psi and °F unit specifications.

Note 3) Bowl assembly for the AL30 to AL60 models comes with a bowl guard (steel band material).

Option/Part No.

Optional specifications	Model						
	AL10	AL20	AL30	AL40	AL40-06	AL50	AL60
Bracket assembly ^{Note)}	—	AF20P-050AS	AF30P-050AS	AF40P-050AS	AF40P-070AS	AF50P-050AS	AF50P-050AS

Note) Assembly of a bracket and 2 mounting screws. The part number for bracket assembly for 1000 cm³ is AF50P-050AS (applicable to the AL30 to AL60).

Semi-standard/Bowl Assembly Part No.

		Semi-standard specifications				Model						
Bowl material	With drain guide	With barb fitting	With bowl guard	With switch		AL10	AL20	AL30	AL40	AL40-06	AL50	AL60
				Lowest limit ON	Lowest limit OFF							
Polycarbonate	●	—	—	—	—	C1SL-3	C2SL-3	C3SL-3	C4SL-3			
	—	—	●	—	—	—	C2SL-C	—	—	—	—	—
	●	—	●	—	—	—	C2SL-3C	—	—	—	—	—
	●	●	—	—	—	—	—	C3SL-3W	C4SL-3W			
Nylon	—	—	—	—	—	C1SL-6	C2SL-6	C3SL-6	C4SL-6			
	●	—	—	—	—	C1SL-36	C2SL-36	C3SL-36	C4SL-36			
	—	—	●	—	—	—	C2SL-6C	—	—	—	—	—
	●	—	●	—	—	—	C2SL-36C	—	—	—	—	—
Metal	—	—	—	—	—	—	C3SL-36W	C4SL-36W				
	—	—	—	—	—	C1SL-2	C2SL-2	C3SL-2	C4SL-2			
Metal bowl with level gauge	●	—	—	—	—	C1SL-23	C2SL-23	C3SL-23	C4SL-23			
	—	—	—	—	—	—	—	C3LL-8	C4LL-8			
1000 cm ³ tank (Metal bowl with level gauge)	—	—	—	—	—	—	—	C3LL-38	C4LL-38			
	—	—	—	—	—	—	—	—	121538-1A			
1000 cm ³ tank (Metal bowl with level gauge)	—	—	—	●	—	—	—	121538-1A-S1	[IS400-1 (Float switch only)]			
	—	—	—	—	●	—	—	121538-1A-S2	[IS400-2 (Float switch only)]			

- Note) • Bowl O-ring (or seal) is included for the AL20 to AL60.
 • Bowl assembly for the AL30 to AL60 models comes with a bowl guard (steel band material). (except when the bowl material is metal)
 • Please consult SMC for psi and °F unit display specifications.
 • When switching bowl materials from a polycarbonate or nylon product to a metal bowl with a level gauge, the oil feed tube assembly must be replaced. (Also, when switching bowl materials from a metal bowl with a level gauge to a polycarbonate or nylon product, the oil feed tube assembly must be replaced.) Please consult SMC separately.
 • It is not possible to switch from a polycarbonate, nylon or metal bowl, or from a metal bowl with a level gauge to a 1000 cm³ tank. Please order the product separately.

* The numbers are the same as the "Construction" of the Best Pneumatics No.5 Series AL.

Filter Regulator / Filter Regulator with Backflow Function

AW10 to AW60 / AW20K to AW60K

Replacement Procedure is P.420

*[BLUE links will lead to purchase pages.](#)

Construction

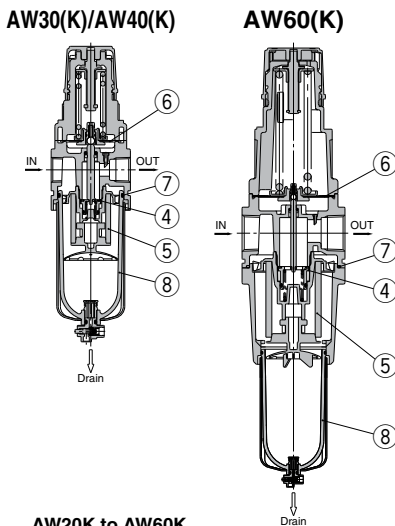
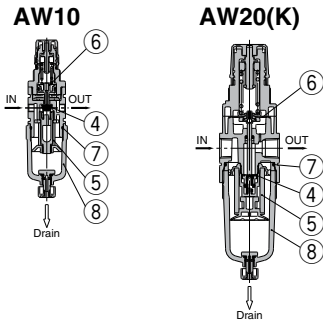

AW20K to AW60K (Filter Regulator with Backflow Function)

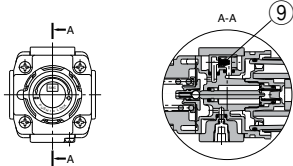

* The numbers are the same as the "Construction" of the Best Pneumatics No.5 Series AW.

Note 1) Assembly of a bracket and set nuts
 Note 2) □ in part numbers for a round pressure gauge indicates a type of connection thread. No indication is necessary for R; however, indicate N for NPT. Please contact SMC regarding the connection thread NPT and pressure gauge supply for psi unit specifications.

Note 3) Standard pressure gauge
 Note 4) Including one O-ring and 2 mounting screws. []: Pressure gauge cover only

Note 5) Lead wire with connector (2 m), adapter, lock pin, O-ring (1 pc.), mounting screw (2 pcs.) are attached. []: Switch body only. Also, regarding how to order the digital pressure switch, please refer to page 388. A pressure switch adapter assembly (AW60P-310AS) will be additionally required for the AW60(K) only. Use the attached mounting screw (M3 x 0.5 x 14) for mounting. The mounting screw (M3 x 0.5 x 7) attached to the digital pressure switch assembly will not be required.

Replacement Parts

No.	Description	Material	Part no.					
			AW10	AW20(K)	AW30(K)	AW40(K)	AW40(K)-06	AW60(K)
4	Valve assembly	Brass, HNBR	AR10P-090S	AW20P-340AS	AW30P-340AS	AW40P-340AS		AW60P-340AS
5	Filter element	Non-woven fabric	AF10P-060S	AF20P-060S	AF30P-060S	AF40P-060S		AW60P-060S
6	Diaphragm assembly	Weather resistant NBR	AR10P-150AS	AR20P-150AS	AR30P-150AS	AR40P-150AS		AR50P-150AS
7	Bowl O-ring	NBR	C1SFP-260S	C2SFP-260S	C3SFP-260S	C4SFP-260S		
8	Bowl assembly	Polycarbonate	C1SF	C2SF	C3SF	C4SF		
9	Check valve assembly	—	—	—	—	—		AR20KP-020AS

Note 1) The AW10 is a piston type. Assembly of a piston and a seal (KSY-P-13).

Note 2) Bowl O-ring is included for the AW20(K) to AW60(K). Please contact SMC regarding the bowl assembly supply for psi and °F unit specifications.

Note 3) Bowl assembly for the AW30(K) to AW60(K) models comes with a bowl guard (steel band material).

Note 4) Check valve assembly is applicable for a filter regulator with backflow function (AW20K to AW60K) only. Assembly of a check valve cover, check valve body assembly and 2 screws

Options/Part No.

Optional specifications		Model					
		AW10(K)	AW20(K)	AW30(K)	AW40(K)	AW40(K)-06	AW60(K)
Bracket assembly ^{Note 1)}		AR10P-270AS	AW20P-270AS	AR30P-270AS	AR40P-270AS		AW60P-270AS
Set nut		AF10P-260S	AF20P-260S	AF30P-260S	AF40P-260S		— ^{Note 7)}
Pressure gauge	Round type ^{Note 2)}	Standard	G27-10-R1	G36-10-□01	G46-10-□02		
		0.02 to 0.2 MPa setting	G27-10-R1	G36-2-□01	G46-2-□02		
	Round type ^{Note 2)} (with color zone)	Standard	—	G36-10-□01-L	G46-10-□02-L		
		0.02 to 0.2 MPa setting	—	G36-2-□01-L	G46-2-□02-L		
Square embedded type ^{Note 4)}	Standard	—	GC3-10AS [GC3P-010AS (Pressure gauge cover only)]				
	0.02 to 0.2 MPa setting	—	GC3-2AS [GC3P-010AS (Pressure gauge cover only)]				
Digital pressure switch ^{Note 5)}	NPN output/Wiring bottom entry	—	ISE35-N-25-MLA [ISE35-N-25-M (Switch body only)]				
	PNP output/Wiring top entry	—	ISE35-R-25-MLA [ISE35-R-25-M (Switch body only)]				
	NPN output/Wiring bottom entry	—	ISE35-N-65-MLA [ISE35-N-65-M (Switch body only)]				
	PNP output/Wiring top entry	—	ISE35-R-65-MLA [ISE35-R-65-M (Switch body only)]				
Float type auto drain ^{Note 8)} ^{Note 9)}	N.C.	AD17	AD27	AD37	AD47		
	N.O.	—	—	AD38	AD48		

Semi-standard/Bowl Assembly Part No.

Semi-standard specifications				Model						
Bowl material	^{Note 8)} ^{Note 9)} Float type auto drain	^{Note 9)} With drain guide	With barb fitting	With bowl guard	AW10(K)	AW20(K)	AW30(K)	AW40(K)	AW40(K)-06	AW60(K)
	Polycarbonate	N.C.	—	—	●	—	C2SF-C	—	—	—
N.O.		—	—	●	—	AD27-C	—	—	—	—
—		—	●	—	—	C2SF-J	C3SF-J	—	C4SF-J	—
—		—	●	—	—	C2SF-W	C3SF-W	—	C4SF-W	—
—		—	●	●	—	C2SF-CJ	—	—	—	—
—		—	●	●	—	C1SF-6	C2SF-6	C3SF-6	—	C4SF-6
Nylon	—	—	—	●	—	C2SF-6C	—	—	—	—
	—	—	—	●	—	AD17-6	AD27-6	AD37-6	—	AD47-6
	—	●	—	—	—	—	AD38-6	—	—	AD48-6
	—	●	—	●	—	AD27-6C	—	—	—	—
	—	—	●	—	—	C2SF-6J	C3SF-6J	—	—	C4SF-6J
	—	—	●	—	—	—	C3SF-6W	—	—	C4SF-6W
Metal	—	—	—	●	—	C2SF-6CJ	—	—	—	—
	—	—	—	—	—	C1SF-2	C2SF-2	C3SF-2	—	C4SF-2
	—	—	—	—	—	AD17-2	AD27-2	AD37-2	—	AD47-2
Metal bowl with level gauge	—	—	—	—	—	C2SF-2J	C3SF-2J	—	—	C4SF-2J
	—	—	—	—	—	C3LF-8	—	—	—	C4LF-8
	—	—	—	—	—	AD37-8	AD38-8	—	—	AD47-8
—	—	—	—	—	—	AD38-8	—	—	AD48-8	
—	—	—	—	—	—	C3LF-8J	—	—	C4LF-8J	

Note 6) Assembly of a bracket and 2 mounting screws

Note 7) Please consult SMC regarding the set nuts for the AW60(K).

Note 8) Minimum operating pressure: N.O. type—0.1 MPa; N.C. type—0.1 MPa (AD27) and 0.15 MPa (AD37/47). Please contact SMC for psi and °F unit specifications.

Note 9) Please consult SMC for details on drain piping to fit NPT or G port sizes.

Note) • Bowl O-ring is included for the AW20(K) to AW60(K).

• Bowl assembly for the AW30(K) to AW60(K) models comes with a bowl guard (steel band material). (except when the bowl material is metal)

Mist Separator Regulator/Micro Mist Separator Regulator

AWM(D)20 to AWM(D)40

Construction

AWM20
AWD20

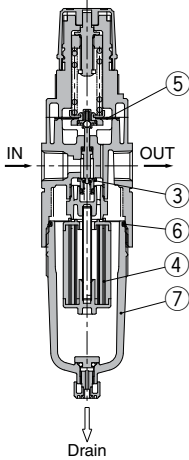

AWM30/40
AWD30/40

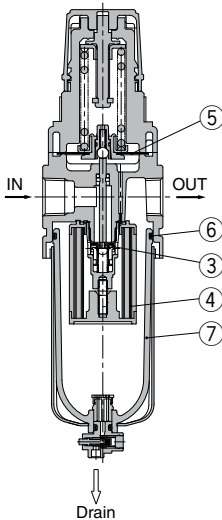

* The numbers are the same as the "Construction" of the Best Pneumatics No.5 Series AWC.

- Note 1) Assembly of a bracket and set nuts
 Note 2) □ in part numbers for a round pressure gauge indicates a type of connection thread. No indication is necessary for R; however, indicate N for NPT. Please contact SMC regarding the connection thread NPT and pressure gauge supply for psi unit specifications.
 Note 3) Including one O-ring and 2 mounting screws. []: Pressure gauge cover only
 Note 4) Lead wire with connector (2 m), adapter, lock pin, O-ring (1 pc.), mounting screw (2 pcs.) are attached. []: Switch body only. Also, regarding how to order the digital pressure switch, please refer to page 388. A separate pressure switch adapter assembly (AW60P-310AS) is required only for AW60(K). For mounting, please use the included mounting screws (M3 x 0.5 x 14). The mounting screw (M3 x 0.5 x 7)

Replacement Parts *BLUE links will lead to purchase pages.

No.	Description	Material	Part no.		
			AWM20 AWD20	AWM30 AWD30	AWM40 AWD40
③	Valve assembly	Brass, HNBR	AWM20P-090AS	AWM30P-090AS	AWM40P-090AS
④	Element assembly	AWM20 to AWM40	AFM20P-060AS	AFM30P-060AS	AFM40P-060AS
		AWD20 to AWD40	AFD20P-060AS	AFD30P-060AS	AFD40P-060AS
⑤	Diaphragm assembly	Weather resistant NBR	AR20P-150AS	AR30P-150AS	AR40P-150AS
⑥	Bowl O-ring	NBR	C2SFP-260S	C3SFP-260S	C4SFP-260S
⑦	Bowl assembly ^{Note 1)}	Polycarbonate	C2SF	C3SF ^{Note 2)}	C4SF ^{Note 2)}

Note 1) Bowl O-ring is included. Please contact SMC regarding the bowl assembly supply for psi and °F unit specifications.

Note 2) Bowl assembly for the AWM30/40, AWD30/40 comes with a bowl guard (steel band material).

Options/Part No.

Optional specifications		Model		
		AWM20 AWD20	AWM30 AWD30	AWM40 AWD40
Bracket assembly ^{Note 1)}		AW20P-270AS	AW30P-270AS	AW40P-270AS
Set nut		AFM20P-060AS	AFM30P-060AS	AFM40P-060AS
Pressure gauge	Round type ^{Note 2)}	Standard	G36-10-□01	G46-10-□02
	Round type ^{Note 2)} (with color zone)	Standard	G36-10-□01-L	G46-10-□02-L
		0.02 to 0.2 MPa setting	G36-2-□01-L	G46-2-□02-L
	Square embedded type ^{Note 3)}	Standard	GC3-10AS [GC3P-010AS (Pressure gauge cover only)]	
Digital pressure switch ^{Note 4)}	0.02 to 0.2 MPa setting		GC3-2AS [GC3P-010AS (Pressure gauge cover only)]	
	NPN output/Wiring bottom entry	ISE35-N-25-MLA	[ISE35-N-25-M (Switch body only)]	
	NPN output/Wiring top entry	ISE35-R-25-MLA	[ISE35-R-25-M (Switch body only)]	
	PNP output/Wiring bottom entry	ISE35-N-65-MLA	[ISE35-N-65-M (Switch body only)]	
	PNP output/Wiring top entry	ISE35-R-65-MLA	[ISE35-R-65-M (Switch body only)]	
Float type auto drain ^{Note 5)} ^{Note 6)}	N.C.	AD27	AD37	AD47
	N.O.	—	AD38	AD48

Semi-standard/Bowl Assembly Part No.

Semi-standard specifications					Model			
Bowl material	Note 5) Note 6)	Note 6)	With drain guide	With barb fitting	With bowl guard	AWM20 AWD20	AWM30 AWD30	AWM40 AWD40
	Float type auto drain	With						
Polycarbonate	—	—	—	—	●	C2SF-C	—	—
	●	—	—	—	●	AD27-C	—	—
	—	—	●	—	—	C2SF-J	C3SF-J	C4SF-J
	—	—	—	●	—	—	C3SF-W	C4SF-W
	—	—	—	—	●	C2SF-CJ	—	—
	—	—	—	—	●	C2SF-6	C3SF-6	C4SF-6
Nylon	—	—	—	—	●	C2SF-6C	—	—
	●	—	—	—	—	AD27-6	AD37-6	AD47-6
	—	●	—	—	—	—	AD38-6	AD48-6
	—	—	—	—	●	AD27-6C	—	—
	—	—	●	—	—	C2SF-6J	C3SF-6J	C4SF-6J
	—	—	—	●	—	—	C3SF-6W	C4SF-6W
Metal	—	—	—	—	●	C2SF-6CJ	—	—
	—	—	—	—	—	C2SF-2	C3SF-2	C4SF-2
	●	—	—	—	—	AD27-2	AD37-2	AD47-2
	—	●	—	—	—	—	AD38-2	AD48-2
Metal bowl with level gauge	—	—	—	—	—	C2SF-2J	C3SF-2J	C4SF-2J
	—	—	—	—	—	—	C3LF-8	C4LF-8
	●	—	—	—	—	—	AD37-8	AD47-8
	—	●	—	—	—	—	AD38-8	AD48-8
	—	—	●	—	—	—	C3LF-8J	C4LF-8J

attached to the digital pressure switch assembly will not be required.

Note 5) Minimum operating pressure: N.O. type—0.1 MPa; N.C. type—0.1 MPa (AD27) and 0.15 MPa (AD37/47). Please contact SMC for psi and °F unit specifications.

Note 6) Please consult SMC for details on drain piping to fit NPT or G port sizes.

Note 7) Including O-ring.

- Bowl assembly for the AWM30/40, AWD30/40 comes with a bowl guard (steel band material). (except when the bowl material is metal)

Series AC/ACG

Air Filter + Regulator + Lubricator AC10 to 60

Options/Attachments Part No.

*[BLUE links will lead to purchase pages.](#)

Section	Model		Options/Attachments Part No.									
			For AC10	For AC20	For AC25	For AC30	For AC40	For AC40-06	For AC50	For AC55	For AC60	
			For AC10A	For AC20A	—	For AC30A	For AC40A	For AC40A-06	For AC50A	—	For AC60A	
Type		For AC10B	For AC20B	For AC25B	For AC30B	For AC40B	For AC40B-06	For AC50B	For AC55B	For AC60B		
		—	For AC20C	For AC25C	For AC30C	For AC40C	For AC40C-06	—	—	—		
		For AC20D	—	—	For AC30D	For AC40D	For AC40D-06	—	—	—		
Options	Round type	Standard	G27-10-R1	G36-10-□01			G46-10-□02					
		0.02 to 0.2 MPa setting	G27-10-R1	G36-2-□01			G46-2-□02					
	Round type (with color zone)	Standard	—	G36-10-□01-L			G46-10-□02-L					
		0.02 to 0.2 MPa setting	—	G36-2-□01-L			G46-2-□02-L					
	Square embedded type	Standard	—	GC3-10AS [GC3P-010AS (Pressure gauge cover only)]								
		0.02 to 0.2 MPa setting	—	GC3-2AS [GC3P-010AS (Pressure gauge cover only)]								
	Digital pressure switch	NPN output/Wiring bottom entry	—	ISE35-N-25-MLA [ISE35-N-25-M (Switch body only)] ^{Note 4)}								
		NPN output/Wiring top entry	—	ISE35-R-25-MLA [ISE35-R-25-M (Switch body only)] ^{Note 4)}								
		PNP output/Wiring bottom entry	—	ISE35-N-65-MLA [ISE35-N-65-M (Switch body only)] ^{Note 4)}								
		PNP output/Wiring top entry	—	ISE35-R-65-MLA [ISE35-R-65-M (Switch body only)] ^{Note 4)}								
Float type auto drain	N.O.	—	AD38			AD48						
	N.C.	AD17	AD27	AD37			AD47					
Attachments	Spacer		Y100	Y200	Y300		Y400	Y500	Y600			
	Check valve ^{Note 6) Note 7)}		—	AKM2000-□01 (□02)	AKM3000-(□01) □02		AKM4000-(□02) □03	—	—	—	—	
	Pressure switch ^{Note 7)}		—	IS1000M-20	IS1000M-30		IS1000M-40	IS1000M-50	IS1000M-60			
	T-interface ^{Note 6) Note 7)}		Y110-M5	Y210-□01 (□02)	Y310-(□01) □02		Y410-(□02) □03	Y510-(□02) □03	Y610-□03 (□04)	Y610-(□03) □04		
	3-port valve for residual pressure release ^{Note 7)}		—	VHS20-□01 □02	VHS30-□02 □03		VHS40-□03 □04	VHS40-□06	VHS50-□06 □10	—	—	
	Piping adapter ^{Note 7)}		E100-M5	□01 E200-□02 □03	□02 E300-□03 □04		□02 E400-□03 □04 □06	E500-□06	E600-□06 □10			
	Pressure switch with piping adapter ^{Note 7)}		—	□01 IS1000E-20□02 □03	□02 IS1000E-30□03 □04		□02 IS1000E-40□03 □04 □06	—	—	—	—	
	Cross spacer ^{Note 7)}		Y14-M5	Y24-□01 □02	Y34-□01 □02		Y44-□02 □03	Y54-□03 □04	—	—	—	

- Note 1) □ in part numbers for a round pressure gauge indicates a type of connection thread. No indication is necessary for R; however, indicate N for NPT. Please contact SMC regarding the connection thread NPT and pressure gauge supply for psi unit specifications.
- Note 2) Including one O-ring and 2 mounting screws
- Note 3) Standard pressure gauge
- Note 4) Lead wire with connector (2 m), adapter, lock pin, O-ring (1 pc.), mounting screw (2 pcs.) are attached. []: Switch body only. Also, regarding how to order the digital pressure switch, please refer to Best Pneumatics No.5.
- Note 5) Minimum operating pressure: N.O. type=0.1 MPa; N.C. type=0.1 MPa (AD17/27) and 0.15 MPa (AD37/47). Please contact SMC for psi and °F unit specifications.
- Note 6) For F.R.L. units, port sizes without () are standard specifications.
- Note 7) Separate interfaces are required for modular unit.

Air Filter + Regulator + Lubricator ACG20/30/40

Options/Attachments Part No.

Description	Model		Options/Attachments part no.		
	Standard	Optional	ACG20	ACG30	ACG40
Pressure gauge ^{Note 1)}	Standard	0 to 1.0 MPa	GB2-10AS	GB3-10AS	GB4-10AS
	Optional	0 to 0.3 MPa	GB2-3AS	GB3-3AS	GB4-3AS
Options	Float type auto drain ^{Note 2)}	N.C.	AD27	AD37	AD47
		N.O.	—	AD38	AD48
Attachments	Spacer		Y200	Y300	Y400
	Spacer with bracket		Y200T	Y300T	Y400T
	Check valve ^{Note 3, 4)}		AKM2000-□01, (□02)	AKM3000-(□01), □02	AKM4000-(□02), □03
	Pressure switch ^{Note 4, 5)}		IS10M-20	IS10M-30	IS10M-40
	Residual pressure relief 3 port valve ^{Note 4)}		VHS20-□01, □02	VHS30-□02, □03	VHS40-□02, □03, □04

- Note 1) Contact SMC regarding the connection thread NPT and pressure gauge supply for psi unit specifications.
- Note 2) Minimum operating pressure: 0.1 MPa for N.O. type, 0.1 MPa for N.C. type (AD27) and 0.15 MPa for N.C. type (AD37 and 47). Contact SMC for psi and °F specifications.
- Note 3) For F.R.L. units, port sizes not in () are for standard application.
- Note 4) Separate spacers are required for modular unit.
- Note 5) Pressure switch cannot be mounted on the inlet and outlet sides of an ARG with an upward facing handle (optional specification: -Y).

Air Combination

Series ACG

Filter Regulator + Lubricator ACG20A/30A/40A

Options/Attachments Part No.

*[BLUE](#) links will lead to purchase pages.

Description		Model	Options/Attachments part no.		
Pressure gauge <small>Note 1)</small>	Standard	0 to 1.0 MPa	ACG20A GB2-10AS	ACG30A GB3-10AS	ACG40A GB4-10AS
	Optional	0 to 0.3 MPa	GB2-3AS	GB3-3AS	GB4-3AS
Options Float type auto drain <small>Note 2)</small>		N.C.	AD27	AD37	AD47
		N.O.	-	AD38	AD48
Attachments Spacer			Y200	Y300	Y400
			Y200T	Y300T	Y400T
			AKM2000-(□01, □02)	AKM3000-(□01), □02	AKM4000-(□02), □03
			VHS20-□01, □02	VHS30-□02, □03	VHS40-□02, □03, □04

Note 1) Contact SMC regarding the connection thread NPT and pressure gauge supply for psi unit specifications.

Note 2) Minimum operating pressure: 0.1 MPa for N.O. type, 0.1 MPa for N.C. type (AD27) and 0.15 MPa for N.C. type (AD37 and 47). Contact SMC for psi and *F specifications.

Note 3) For F.R.L. units, port sizes not in () are for standard application.

Note 4) Separate spacers are required for modular unit.

Air Filter + Regulator ACG20B/30B/40B

Options/Attachments Part No.

Description		Model	Options/Attachments part no.		
Pressure gauge <small>Note 1)</small>	Standard	0 to 1.0 MPa	ACG20B GB2-10AS	ACG30B GB3-10AS	ACG40B GB4-10AS
	Optional	0 to 0.3 MPa	GB2-3AS	GB3-3AS	GB4-3AS
Options Float type auto drain <small>Note 2)</small>		N.C.	AD27	AD37	AD47
		N.O.	-	AD38	AD48
Attachments Spacer			Y200	Y300	Y400
			Y200T	Y300T	Y400T
			IS10M-20	IS10M-30	IS10M-40
			VHS20-□01, □02	VHS30-□02, □03	VHS40-□02, □03, □04

Note 1) Contact SMC regarding pressure gauge supply for psi unit specifications.

Note 2) Minimum operating pressure: 0.1 MPa for N.O. type, 0.1 MPa for N.C. type (AD27) and 0.15 MPa for N.C. type (AD37 and 47). Contact SMC for psi and *F specifications.

Note 3) Separate spacers are required for modular unit.

Note 4) Pressure switch cannot be mounted on the inlet and outlet sides of an ARG with an upward facing handle (optional specification: -Y).

Air Filter + Mist Separator + Regulator ACG20C/30C/40C

Options/Attachments Part No.

Description		Model	Options/Attachments part no.		
Pressure gauge <small>Note 1)</small>	Standard	0 to 1.0 MPa	ACG20C GB2-10AS	ACG30C GB3-10AS	ACG40C GB4-10AS
	Optional	0 to 0.3 MPa	GB2-3AS	GB3-3AS	GB4-3AS
Options Float type auto drain <small>Note 2)</small>		N.C.	AD27	AD37	AD47
		N.O.	-	AD38	AD48
Attachments Spacer			Y200	Y300	Y400
			Y200T	Y300T	Y400T
			IS10M-20	IS10M-30	IS10M-40
			VHS20-□01, □02	VHS30-□02, □03	VHS40-□02, □03, □04

Note 1) Contact SMC regarding pressure gauge supply for psi unit specifications.

Note 2) Minimum operating pressure: 0.1 MPa for N.O. type, 0.1 MPa for N.C. type (AD27) and 0.15 MPa for N.C. type (AD37 and 47). Contact SMC for psi and *F specifications.

Note 3) Separate spacers are required for modular unit.

Note 4) Pressure switch cannot be mounted on the inlet and outlet sides of an ARG with an upward facing handle (optional specification: -Y).

Filter Regulator + Mist Separator ACG20D/30D/40D

Options/Attachments Part No.

Description		Model	Options/Attachments part no.		
Pressure gauge <small>Note 1)</small>	Standard	0 to 1.0 MPa	ACG20D GB2-10AS	ACG30D GB3-10AS	ACG40D GB4-10AS
	Optional	0 to 0.3 MPa	GB2-3AS	GB3-3AS	GB4-3AS
Options Float type auto drain <small>Note 2)</small>		N.C.	AD27	AD37	AD47
		N.O.	-	AD38	AD48
Attachments Spacer			Y200	Y300	Y400
			Y200T	Y300T	Y400T
			VHS20-□01, □02	VHS30-□02, □03	VHS40-□02, □03, □04

Note 1) Contact SMC regarding pressure gauge supply for psi unit specifications.

Note 2) Minimum operating pressure: 0.1 MPa for N.O. type, 0.1 MPa for N.C. type (AD27) and 0.15 MPa for N.C. type (AD37 and 47). Contact SMC for psi and *F specifications.

Note 3) Separate spacers are required for modular unit.

Regulator with Built-in Pressure Gauge

ARG20(K)/30(K)/40(K)

Replacement
Procedure is
P.431

Construction

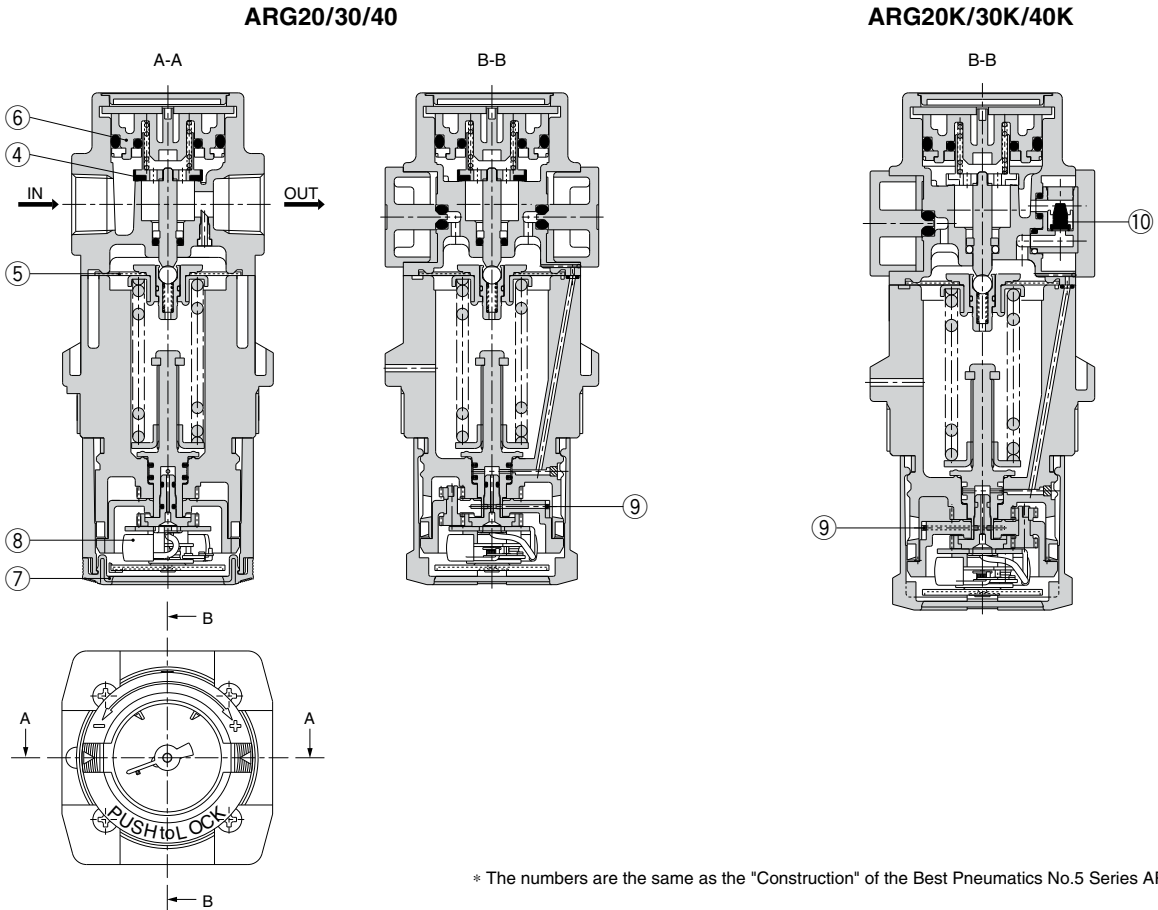

* The numbers are the same as the "Construction" of the Best Pneumatics No.5 Series ARG.

*[BLUE](#) links will lead to purchase pages.

Replacement Parts

No.	Description	Material	Qty.	Part no.			Note
				ARG20(K)	ARG30(K)	ARG40(K)	
4	Valve	Brass, HNBR	1	AR20P-410S	AR30P-410S	AR40P-410S	
5	Diaphragm assembly	Weather resistant NBR	1	AR20P-150AS	AR30P-150AS	AR40P-150AS	
6	Valve guide assembly	POM, NBR	1	AR20P-050AS	AR30P-050AS	AR40P-050AS	
7	Pressure gauge cover	PC	1	ARG20P-400S	ARG30P-400S	ARG40P-400S	
8	Pressure gauge ^{Note 1)}	—	1	GB2-10AS	GB3-10AS	GB4-10AS	
9	Clip	Stainless steel	1	AR20P-420S	AR30P-420S	AR40P-420S	
10	Check valve assembly ^{Note 2)}	—	1	AR20KP-020AS			ARG20K, 30K, 40K

Note 1) Only the standard part numbers are listed for the pressure gauges.

Note 2) Check valve assembly contains check valve, check valve cover and its screws (2 pcs).

Options/Part No.

		Applicable model		ARG20(K)	ARG30(K)	ARG40(K)
Option						
Bracket assembly ^{Note 1)}				ARG20P-270AS	ARG30P-270AS	ARG40P-270AS
Set nut				ARG20P-260AS	ARG30P-260AS	ARG40P-260AS
Pressure gauge	Pressure gauge display range	Standard	0 to 1.0 MPa	GB2-10AS	GB3-10AS	GB4-10AS
			0 to 0.3 MPa	GB2-3AS	GB3-3AS	GB4-3AS
		Optional	0 to 150 psi	GB2-P10AS	GB3-P10AS	GB4-P10AS
			0 to 45 psi	GB2-P3AS	GB3-P3AS	GB4-P3AS

Note 1) Assembly includes a bracket and set nuts.

Filter Regulator with Built-in Pressure Gauge

AWG20/30/40

Replacement
Procedure is
P.437

Construction

AWG20

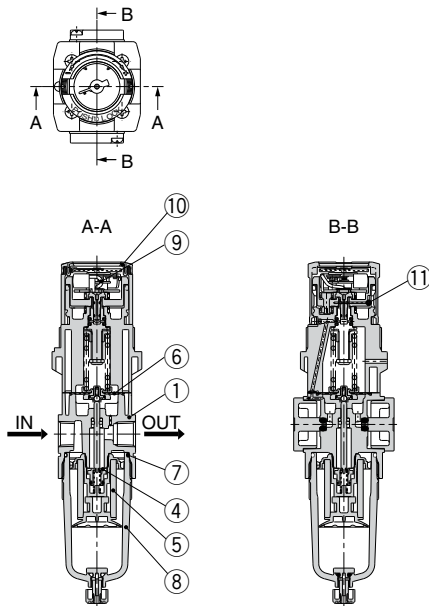

AWG30/40

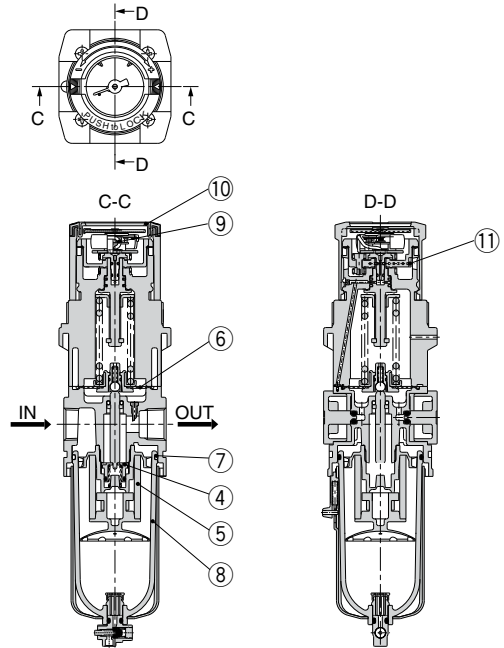

*[BLUE](#) links will lead to purchase pages.

* The numbers are the same as the "Construction" of the Best Pneumatics No.5 Series AWG.

Replacement Parts

No.	Description	Material	Qty.	Part no.			Note
				AWG20	AWG30	AWG40	
4	Valve assembly	Brass, HNBR	1	AW20P-340AS	AW30P-340AS	AW40P-340AS	
5	Filter element	Non-woven fabric	1	AF20P-060S	AF30P-060S	AF40P-060S	
6	Diaphragm assembly	Weather resistant NBR	1	AR20P-150AS	AR30P-150AS	AR40P-150AS	
7	Bowl O-ring	NBR	1	C2SFP-260S	C3SFP-260S	C4SFP-260S	
8	Bowl assembly ^{Note 1)}	PC	1	C2SF	C3SF ^{Note 2)}	C4SF ^{Note 2)}	
9	Pressure gauge ^{Note 3)}	—	1	GB2-10AS	GB3-10AS	GB4-10AS	
10	Pressure gauge cover	PC	1	ARG20P-400S	ARG30P-400S	ARG40P-400S	
11	Clip	Stainless steel	1	ARG20P-420S	ARG30P-420S	ARG40P-420S	

Note 1) Including O-ring. Contact SMC regarding the bowl assembly supply for psi and °F unit specifications.

Note 2) Bowl assembly for AWG30/40 includes a bowl guard (steel band material).

Note 3) Only the standard part numbers are listed in the pressure gauges. For the semi-standard part numbers, refer to the optional part numbers.

Options/Part No.

Option		Applicable model		AWG20	AWG30	AWG40
Bracket assembly ^{Note 1)}				ARG20P-270AS	ARG30P-270AS	ARG40P-270AS
Set nut				ARG20P-260AS	ARG30P-260AS	ARG40P-260AS
Pressure gauge	Pressure gauge display range	Standard	0 to 1.0 MPa	GB2-10AS	GB3-10AS	GB4-10AS
			0 to 0.3 MPa	GB2-3AS	GB3-3AS	GB4-3AS
		Optional	0 to 150 psi	GB2-P10AS	GB3-P10AS	GB4-P10AS
			0 to 45 psi	GB2-P3AS	GB3-P3AS	GB4-P3AS
Float type auto drain ^{Note 2)}			N.O.	—	AD38	AD48
			N.C.	AD27	AD37	AD47

Note 1) Assembly includes a bracket and set nuts.

Note 2) Minimum operating pressure: N.O. type–0.1 MPa; N.C. type–0.1 MPa (AD27) and 0.15 MPa (AD37/47). Contact SMC regarding the specifications for psi unit and °F.

Filter Regulator with Built-in Pressure Gauge with Backflow Function

AWG20K/30K/40K

Construction

AWG20K

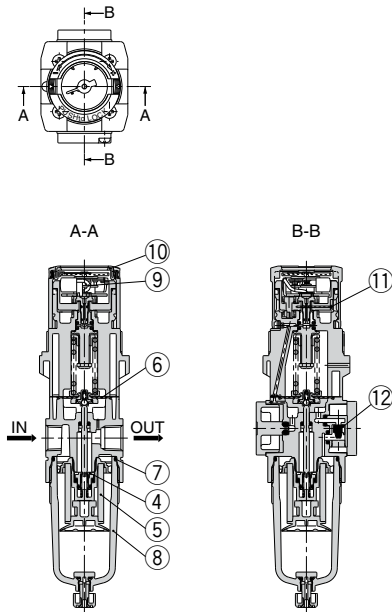

AWG30K/40K

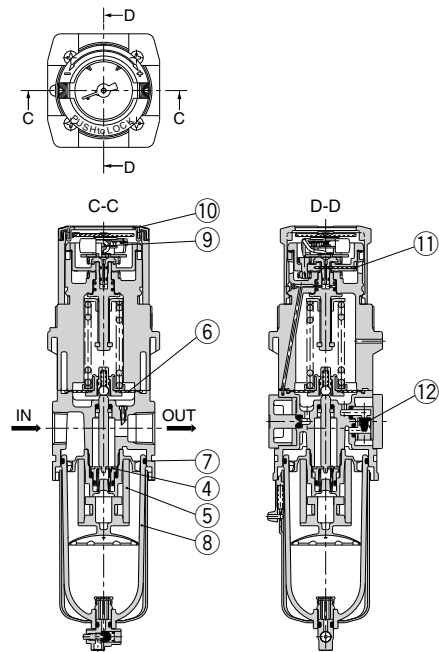

* The numbers are the same as the "Construction" of the Best Pneumatics No.5 Series AWG.

*[BLUE](#) links will lead to purchase pages.

Replacement Parts

No.	Description	Material	Qty.	Part no.			Note
				AWG20K	AWG30K	AWG40K	
4	Valve assembly	Brass, HNBR	1	AW20P-340AS	AW30P-340AS	AW40P-340AS	
5	Filter element	Non-woven fabric	1	AF20P-060S	AF30P-060S	AF40P-060S	
6	Diaphragm assembly	Weather resistant NBR	1	AR20P-150AS	AR30P-150AS	AR40P-150AS	
7	Bowl O-ring	NBR	1	C2SFP-260S	C3SFP-260S	C4SFP-260S	
8	Bowl assembly ^{Note 1)}	PC	1	C2SF	C3SF ^{Note 2)}	C4SF ^{Note 2)}	
9	Pressure gauge ^{Note 3)}	—	1	GB2-10AS	GB3-10AS	GB4-10AS	
10	Pressure gauge cover	PC	1	ARG20P-400S	ARG30P-400S	ARG40P-400S	
11	Clip	Stainless steel	1	ARG20P-420S	ARG30P-420S	ARG40P-420S	
12	Check valve assembly	—	1	AR20KP-020AS			

Note 1) Including O-ring. Contact SMC regarding the bowl assembly supply for psi and °F unit specifications.

Note 2) Bowl assembly (AWG30K/40K) includes a bowl guard (steel band material).

Note 3) Only the standard part numbers are listed for the pressure gauges. For the semi-standard part numbers, refer to the optional part numbers.

Options/Part No.

Option		Applicable model		AWG20K	AWG30K	AWG40K
Bracket assembly ^{Note 1)}				ARG20P-270AS	ARG30P-270AS	ARG40P-270AS
Set nut				ARG20P-260AS	ARG30P-260AS	ARG40P-260AS
Pressure gauge	Pressure gauge display range	Standard	0 to 1.0 MPa	GB2-10AS	GB3-10AS	GB4-10AS
			0 to 0.3 MPa	GB2-3AS	GB3-3AS	GB4-3AS
		Optional	0 to 150 psi	GB2-P10AS	GB3-P10AS	GB4-P10AS
			0 to 45 psi	GB2-P3AS	GB3-P3AS	GB4-P3AS
Float type auto drain ^{Note 2)}		N.O.	—	AD38	AD48	
		N.C.	AD27	AD37	AD47	

Note 1) Assembly includes a bracket and set nuts.

Note 2) Minimum operating pressure: N.O. type—0.1 MPa; N.C. type—0.1 MPa (AD27) and 0.15 MPa (AD37/47). Contact SMC regarding the specifications for psi unit and °F.

Pilot Operated Regulator

AR425 to 935

Replacement
Procedure is
p.444

Construction

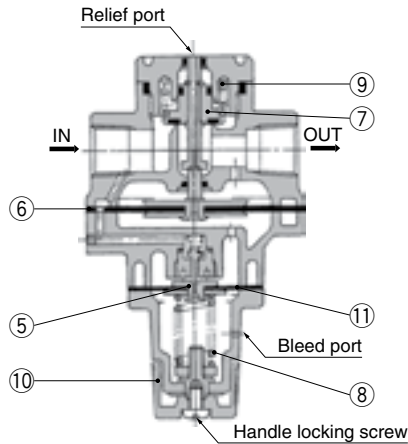

* The numbers are the same as the "Construction" of the Best Pneumatics No.5 Series AR.

*[BLUE](#) links will lead to purchase pages.

Replacement Parts

No.	Description	Material	Qty.	Part no.				Note
				AR425/435	AR625/635	AR825/835	AR925/935	
5, 11	Exhaust valve assembly ^{Note 1)}	—	1	132586A	132586A	132586A	132586A	
6	Main valve side diaphragm assembly	—	1	132581A	132659A	13275A	13285A	
7	Valve assembly	—	1	132572A	132653A	132752A	132829A	
8	Adjusting spring	Steel wire	1	135053 (AR425) 135025 (AR435)	135053 (AR625) 135025 (AR635)	135053 (AR825) 135025 (AR835)	135053 (AR925) 135025 (AR935)	
9	Valve spring	Stainless steel	1	135211	132656	132713	132829	
10	Handle	ABS	1	13414				

Note 1) Diaphragm is included.

Options/Part No.

Description	Model	Part no.			
		AR4□5	AR6□5	AR8□5	AR9□5
Bracket		B24P	B25P	—	—
Pressure gauge with limit indicator ^{Note 1)}		G46-10-□02 (Max. 1.0 MPa), G46-2-□02 (Max. 0.2 MPa)			

Note 1) • In the gauge part no. (e.g. G46-10-□02), □ indicate kind of the connecting thread. Put nothing for Rc and "N" for NPT thread.

• Please consult with SMC for NPT pressure gauge.

Note 2) Use caution not to tighten excessively when mounting a pressure gauge, otherwise it may result in a breakdown. Use a pipe tape for sealing.
Recommended torque: 12 to 14 N·m.

Actuators

Modular FRL
Pressure Control Equipment

Air Preparation
Equipment

Industrial Filters

Replacement
Procedure

Actuators

Modular FRL
Pressure Control Equipment

Industrial Filters

AMR3000 to 6000

Replacement
Procedure is
p.448

Construction

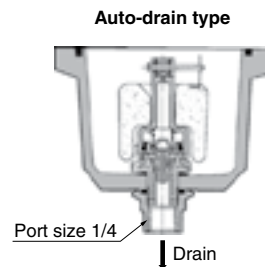
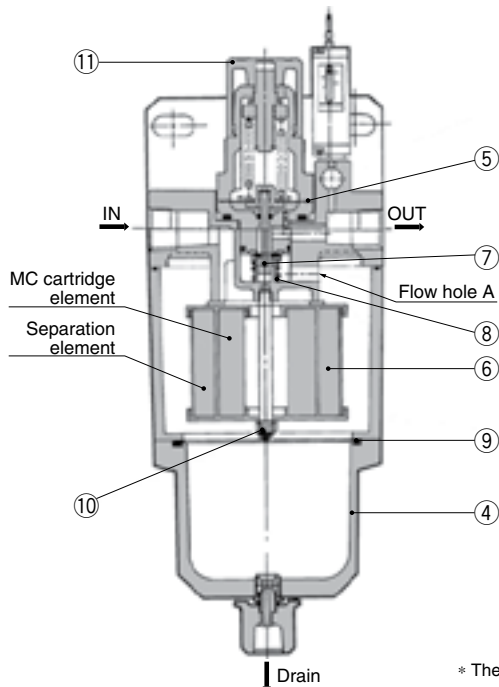

* The numbers are the same as the "Construction" of the Best Pneumatics No.5 Series AMR.

Replacement Parts [*BLUE links will lead to purchase pages.](#)

No.	Description	Material	Qty	Part no.				Note
				AMR3000	AMR4000	AMR5000	AMR6000	
4	Bowl assembly	Aluminum die-casted	1	13573A	13553A	13583A	13563A	
5	Diaphragm assembly	Weather resistant NBR	1	1349161A	131515A	131515A	131614A	
6	Element ^{Note)}	—	1	13579	135511	13589	13569	
7	Valve assembly	Brass, HNBR	1	135711A	13154A	135811A	135614-1A	
8	Valve spring	Stainless steel	1	135011	131514	131613	135413	
9	O-ring	NBR	1	G75	G90	G100	G115	
10	Gasket	Fiber	1	135714	635327	635327	63555	
11	Handle	POM	1	1349167	131534	131534	131634	

Note) The MC cartridge element and the separation element are integrated.

Accessory (Standard)/Part No.

Model name	Model	AMR3000	AMR4000	AMR5000	AMR6000
Bracket		13576	13556	13587	13568
Pressure gauge ^{Note 5, 6)}	1.0MPa	G36-10-□01		G46-10-□02	

Accessory (Option)/Part No.

Model name	Model	AMR3000	AMR4000	AMR5000	AMR6000
Adapter assembly ^{Note 7)}		1/4:E3-□02 3/8:E3-□03	1/4:E4-□02 3/8:E4-□03 1/2:E4-□04	1/2:E5-□04 3/4:E5-□06	3/4:E6-□06 1:E6-□10
Float style auto drain (AMR□100) ^{Note 8)}		AD33-X203	AD33X202	AD33-X210	AD33-X201
Compact pressure switch		(0.4 MPa setting)			
Elbow (R x Rc) ^{Note 9)}		135510		135613	

Note 5) □ in the gauge part number (e.g. G36-10-□01) indicates thread. Specify no symbol for "Rc", and "N" for "NPT".

• Please consult with SMC if "NPT" gauge is required.

Note 6) Use caution not to tighten excessively when mounting a pressure gauge, otherwise it may result in a breakdown. Use a pipe tape for sealing.

Recommended tightening torque for pressure regulator: R 1/8 = 7 to 9 N·m, R 1/4 = 12 to 14 N·m

Note 7) Piping adapter, O-ring, Hexagon socket bolt, Hexagon socket bolt assembly. These are shipped together with products. "□" in the gauge part number indicates thread type. Specify no symbol for "RC", "N" for "NPT", and "G" for "F".

Note 8) Min. operating pressure = 0.1 MPa

Note 9) If a compact pressure switch is mounted later on, an elbow (R x Rc) is necessary.

Series ARM5A

Replacement
Procedure is
p. 449

Construction

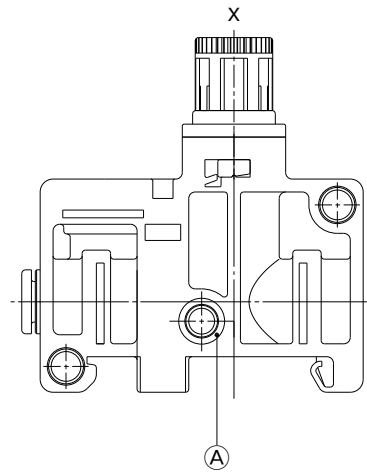
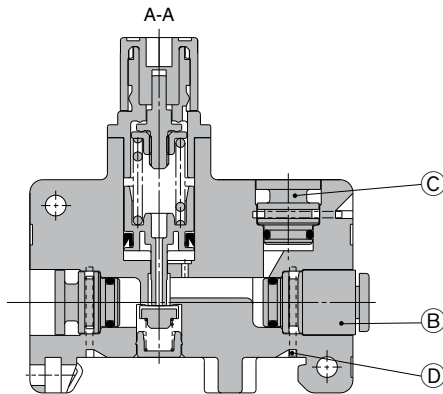
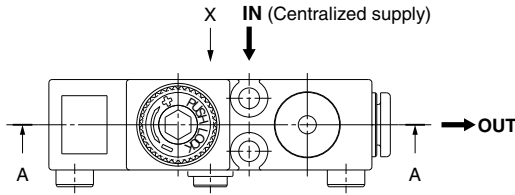

*BLUE links will lead to purchase pages.

Replacement Parts

No.	Description	Material	Qty.	Part no.
A	O-ring	NBR	1	136019
B	Fitting assembly	—	1	See below
C	Port plug	PBT, HNBR	1	See below
D	Clip	Stainless steel	3	136010

* The numbers are the same as the "Construction" of the Best Pneumatics No.5 Series ARM5A.

One-touch Fittings for Centralized Supply Block

VVQ1000-51A - **C6**

One-touch fittings for centralized supply block

Fitting type

Nil	Straight
L1	Elbow

Fitting size

Symbol	Size
C6	ø6
C8	ø8
N7	ø1/4
N9	ø5/16



Straight type

Elbow type

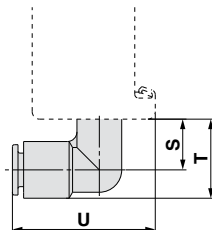
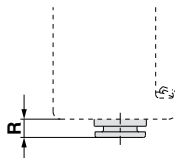

Port Plug

VVQ0000-58A

Single unit regulator/
Port plug for regulator block

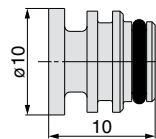

Note) The O-ring is attached. Refer to page 449 for details of the replacement.

Fitting size	One-touch fittings for centralized supply block			
	Straight	Elbow	Elbow	Elbow
	R	S	T	U
ø4, ø5/32	—	—	—	—
ø6	3	12.5	19	35.5
ø1/4	3	12.5	19	35.5
ø8, ø5/16	5	13.5	21	38.5

Note) The O-ring is attached. Refer to page 449 for details of the replacement.

Compact Manifold Regulator/Individual Supply Type

Series ARM5B

Replacement
Procedure is
p.449

Construction

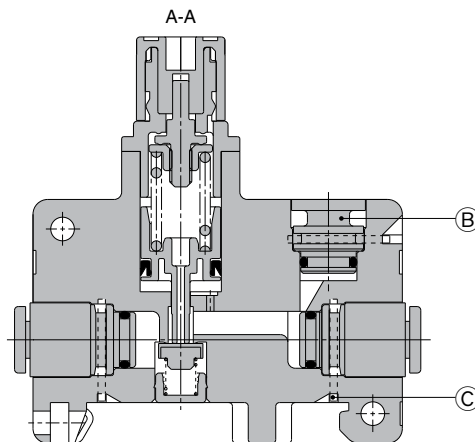
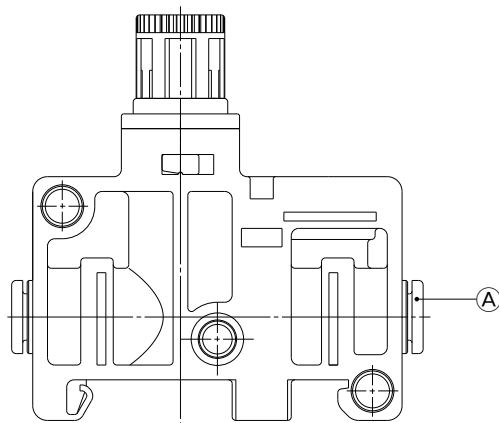
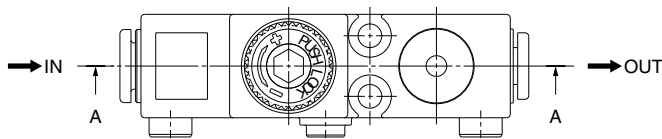

*BLUE links will lead to purchase pages.

Replacement Parts

No.	Description	Material	Qty.	Part no.
A	Fitting assembly	—	2	See below
B	Port plug	PBT, HNBR	1	See below
C	Clip	Stainless steel	3	136010

* The numbers are the same as the "Construction" of the Best Pneumatics No.5 Series ARM5B.

One-touch Fittings for Regulator Block

VVQ1000-50A - [] C4

One-touch fittings for regulator block

Fitting type	
Nil	Straight
L1	Elbow



Straight type

Fitting size	
Symbol	Size
C4	ø4
C6	ø6
N3	ø5/32
N7	ø1/4

Elbow type

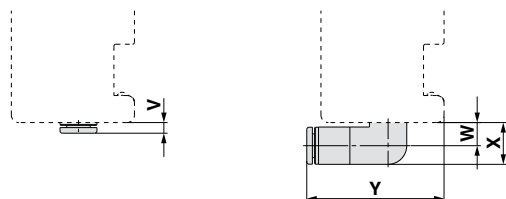

Port Plug

VVQ000-58A

Single unit regulator/
Port plug for regulator block

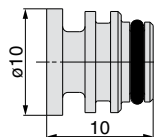

Note) The O-ring is attached. Refer to page 449 for details of the replacement.

Fitting size	One-touch fittings for regulator block			
	Straight	Elbow	Elbow	Elbow
	V	W	X	Y
ø4, ø5/32	2.5	6	11	35.5
ø6	3	6.5	11	36
ø1/4	6.5	6	11.5	38.5
ø8, ø5/16	—	—	—	—

Note) The O-ring is attached. Refer to page 449 for details of the replacement.

Series ARM5S

Replacement
Procedure is
p.449

Construction

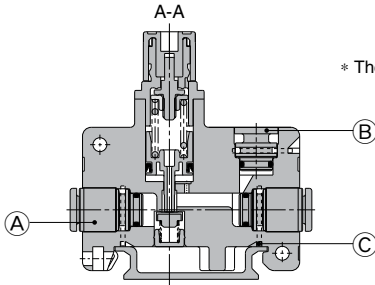
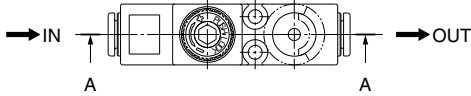

* The numbers are the same as the "Construction" of the Best Pneumatics No.5 Series ARM5S.

*[BLUE](#) links will lead to purchase pages.

Replacement Parts

No.	Description	Material	Qty.	Part no.
A	Fitting assembly	—	2	See below
B	Port plug	PBT, HNBR	1	See below
C	Clip	Stainless steel	3	136010

One-touch Fittings for Regulator

VVQ1000-50A - [] C4

One-touch fittings
for regulator

Fitting type

Nil	Straight
L1	Elbow

Fitting size

C4	ø4
C6	ø6
N3	ø5/32
N7	ø1/4

Straight type

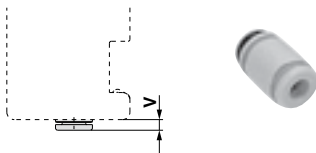

Elbow type

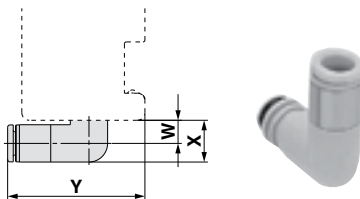

Port Plug

VVQ0000-58A

Single unit regulator/
Port plug for regulator block

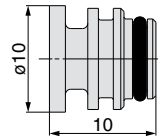

Note) The O-ring is attached.
Refer to page 449 for details of the replacement.

Fitting size	One-touch fittings for regulator			
	Straight	Elbow	Elbow	Elbow
	V	W	X	Y
ø4, ø5/32	2.5	6	11	35.5
ø6	3	6.5	11	36
ø1/4	6.5	6	11.5	38.5
ø8, ø5/16	—	—	—	—

Note) The O-ring is attached.
Refer to page 449 for details of the replacement.

Series ARM10

Replacement
Procedure is
P.453

Construction

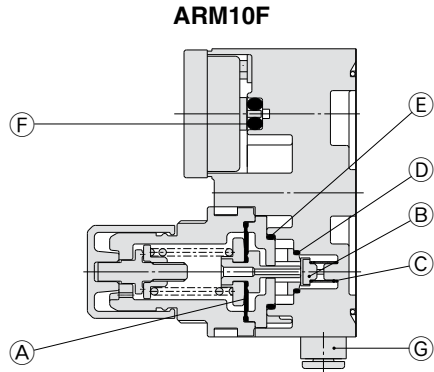
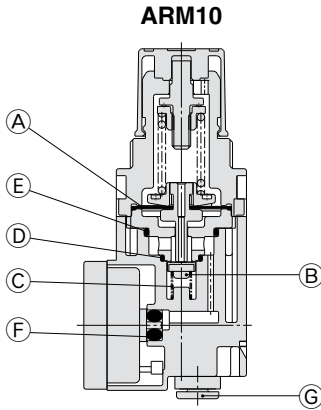

*[BLUE](#) links will lead to purchase pages.

Replacement Parts

No.	Description	Material	Part no.	Note
A	Diaphragm assembly	Weather resistant	136126A	Relieving type
		NBR, POM	136126-1A	Non-relieving type
B	Valve	HNBR, Aluminum alloy	136127-30#1	
C	Valve spring	Stainless steel	136131	
D	O-ring	NBR	136146	Standard model
		HNBR	136146-30	Oil-free specification
E	O-ring	NBR	136147	Standard model
		HNBR	136147-30	Oil-free specification
F	O-ring	NBR	136148	Standard model
		HNBR	136148-30	Oil-free specification
		NBR	KA01731	Standard model for digital pressure switch
		HNBR	KA01613	Oil-free spec. for digital pressure switch
G	Fitting assembly	—	The right reference	

* The numbers are the same as the "Construction" of the Best Pneumatics No.5 Series ARM10.

One-touch Fittings for Regulator

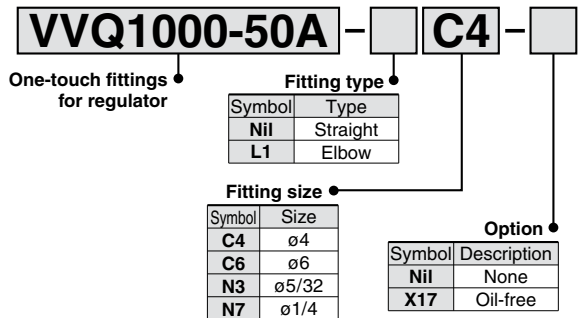

ARM10

Straight type

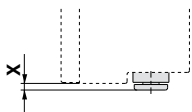

Fitting size	X
ø4, ø5/32	2
ø6	2
ø1/4	6

Elbow type

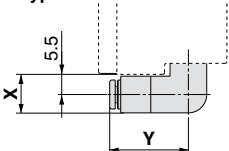

Fitting size	X	Y
ø4, ø5/32	10.5	21.5
ø6	10.5	22
ø1/4	10.5	24.5

ARM10F

Straight type

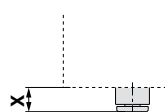

Fitting size	X
ø4, ø5/32	7
ø6	7
ø1/4	11

Elbow type

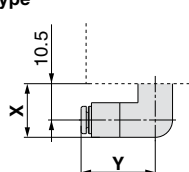

Fitting size	X	Y
ø4, ø5/32	15.5	21.5
ø6	15.5	22
ø1/4	15.5	24.5

Compact Manifold Regulator/Common Supply Type

Series ARM11A

Replacement
Procedure is
p.453

Construction

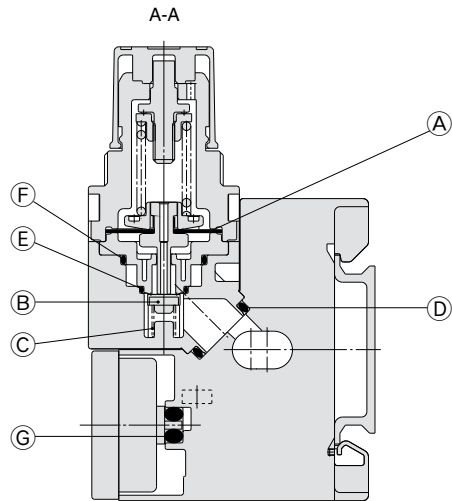
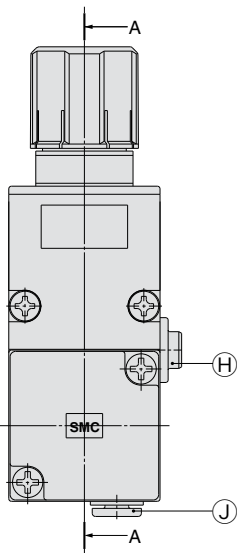
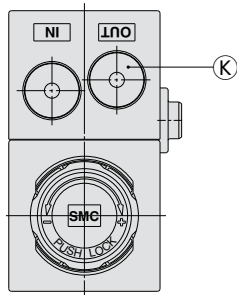

*[BLUE links](#) will lead to purchase pages.

* The numbers are the same as the "Construction" of the Best Pneumatics No.5 Series ARM11A.

Replacement Parts

No.	Description	Material	Part no.	Note
A	Diaphragm assembly	Weather resistant NBR, POM	136126A	Relieving type
			136126-1A	Non-relieving type
B	Valve	HNBR, Aluminum alloy	136127-30#1	
C	Valve spring	Stainless steel	136131	
D	Gasket	HNBR	136137-30	
E	O-ring	NBR	136146	Standard model
		HNBR	136146-30	Oil-free specification
F	O-ring	NBR	136147	Standard model
		HNBR	136147-30	Oil-free specification
G	O-ring	NBR	136148	Standard model
		HNBR	136148-30	Oil-free specification
		NBR	KA01731	Standard model for digital pressure switch
		HNBR	KA01613	Oil-free spec. for digital pressure switch
H	O-ring	NBR	136149	Standard model
		HNBR	136149-30	Oil-free specification
J	Fitting assembly	—	Refer to page 239.	
K	Port plug	PBT/HNBR	Refer to page 239.	

Compact Manifold Regulator/Individual Supply Type

Series ARM11B

Replacement
Procedure is
p.453

Construction

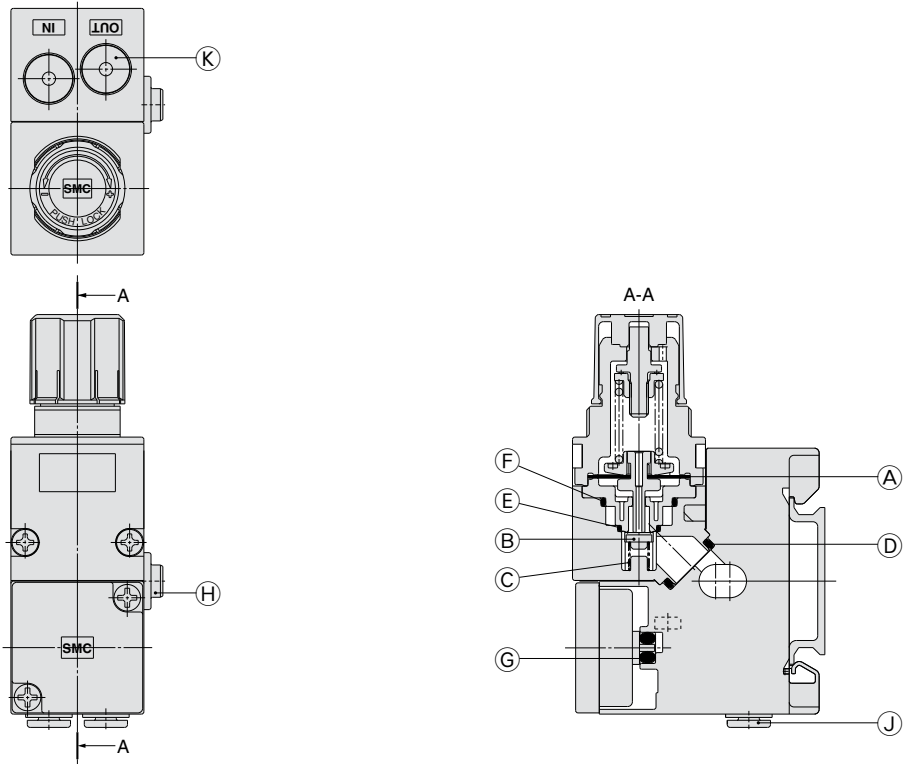

* The numbers are the same as the "Construction" of the Best Pneumatics No.5 Series ARM11B.

*[BLUE](#) links will lead to purchase pages.

Replacement Parts

No.	Description	Material	Part no.	Note	
A	Diaphragm assembly	Weather resistant NBR, POM	136126A	Relieving type	
			136126-1A	Non-relieving type	
B	Valve	HNBR, Aluminum alloy	136127-30#1		
C	Valve spring	Stainless steel	136131		
D	Gasket	HNBR	136137-30		
E	O-ring	NBR	136146	Standard model	
			HNBR	136146-30	Oil-free specification
F	O-ring	NBR	136147	Standard model	
			HNBR	136147-30	Oil-free specification
G	O-ring	NBR	136148	Standard model	
			HNBR	136148-30	Oil-free specification
			NBR	KA01731	Standard model for digital pressure switch
H	O-ring	HNBR	KA01613	Oil-free spec. for digital pressure switch	
			NBR	136149	Standard model
J	Fitting assembly	HNBR	136149-30	Oil-free specification	
K	Port plug	—	Refer to page 239.		
		PBT/HNBR	Refer to page 239.		

Compact Manifold Regulator Series ARM11A/B

Options

Replacement Procedure is p.453

One-touch Fittings for Regulator Block

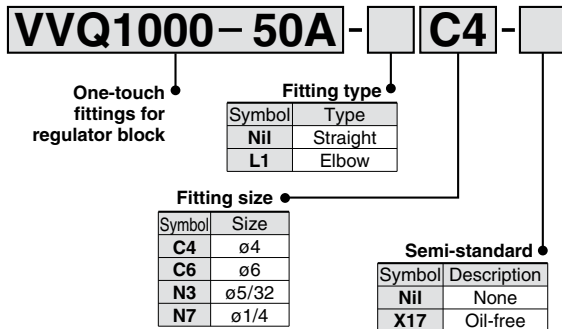

Straight type

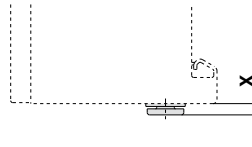

Fitting size	X
ø4, ø5/32	3
ø6	3
ø1/4	7

Elbow type

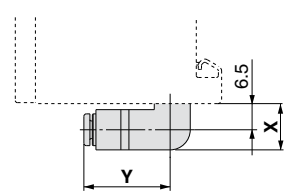

Fitting size	X	Y
ø4, ø5/32	11.5	19
ø6	11.5	19.5
ø1/4	11.5	22

One-touch Fittings for Common Supply Block

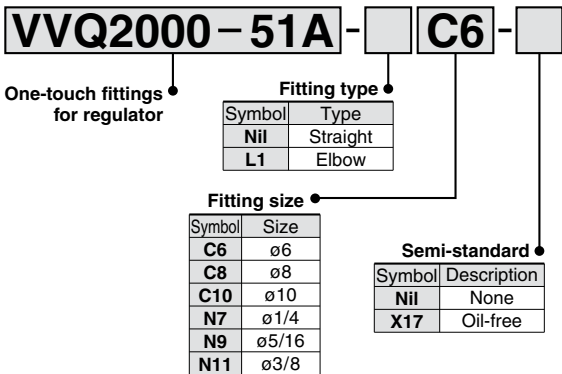

Straight type

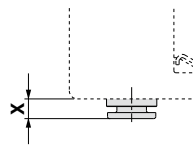

Fitting size	X
ø6	5
ø8, ø5/16	5
ø10, ø3/8	5.5
ø1/4	5

Elbow type

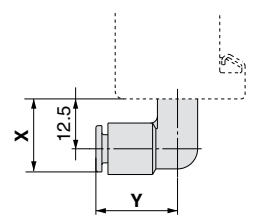

Fitting size	X	Y
ø6	19	20
ø8, ø5/16	20	23
ø10, ø3/8	22	26
ø1/4	19	20.5

Port Plug

VVQ0000-58A -

Single unit regulator/
Port plug for regulator block

Semi-standard	
Symbol	Description
Nil	None
X17	Oil-free

