

Air Cylinder



ø125 newly introduced

Series MB

ø32, ø40, ø50, ø63, ø80, ø100, ø125

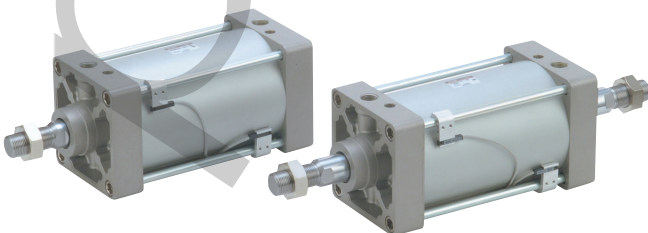

Series MB, MBW, MBK,

ø125 newly introduced
(Double acting single rod, Double acting double rod)

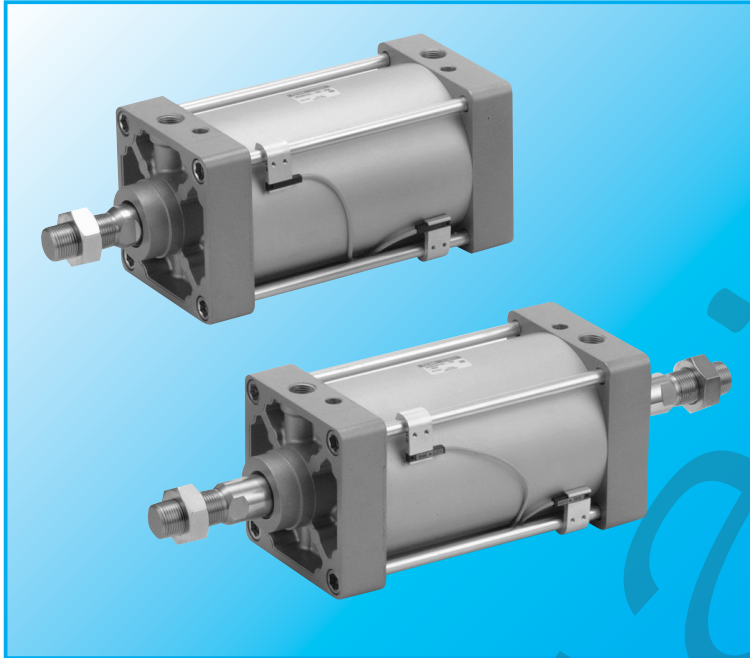

Increased kinetic energy absorption

Elevated cushion volume and the adoption of a new cushion seal design permit about 30% more allowable kinetic energy over the CA1 series. In addition, service life of cushion seal is about 5 times greater.

Improved cushion capacity

"Floating" cushion seal design eliminates piston rod "bouncing" due to cracking pressure at beginning of stroke.

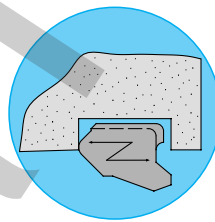

Compact and lightweight design

The square cover is made more compact than the CA1 series. In addition, die cast covers yield 10 to 25% weight reduction over the CA1 series.



Minimal rod deflection

Improved bushing and piston rod dimensional accuracy achieves tighter clearances and reduced piston rod deflection.

Accurate mounting

The cylinder cover and mounting bracket with high dimensional accuracy simplifies installation and extends service life.

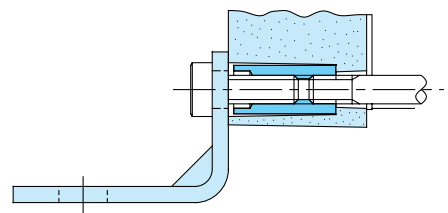

Air Cylinder/Single Rod

Series MB

ø32, ø40, ø50, ø63, ø80, ø100, ø125

How to Order

Standard

With auto switch

MB L 32 50

MDB L 32 50 Y7BW

Number of auto switches

—	2
S	1
3	3
n	n

Built-in magnet

Mounting

B	Basic/Without bracket
L	Axial foot
F	Front flange
G	Rear flange
C	Single clevis
D	Double clevis
T	Center trunnion

Bore size

32	32mm
40	40mm
50	50mm
63	63mm
80	80mm
100	100mm
125	125mm

Auto switch

—	Without auto switch
---	---------------------

* Refer to table below for selection of applicable auto switch.
* The auto switches for D-Z7□, Z80, Y59□, Y69□, Y7□□ are included but unmounted.
(Only the switch mounting brackets for the above models are mounted.)

Port thread type

Symbol	Type
—	Rc
TN	NPT
TF	G

Stroke (mm)

Refer to page 2 for standard stroke table.

Rod boot/Cushion

Rod boot	—	None
	J	Nylon tarpaulin
Cushion	K	Heat resistant tarpaulin
	—	Both ends
	N (Note 1)	None

Note 1) Model without air cushion is designed to include rubber bumpers. The overall length is longer than the cylinder with air cushions because the bumpers are attached to the both sides of the piston as follows.
ø32, ø40: +6mm, ø50, ø63: +8mm, ø80, ø100: +10mm, ø125: +12mm

Applicable Auto Switches/ For detailed specifications, please refer to Best Pneumatics Vol.2 page 5.3-2.

Style	Special function	Electrical entry	Indicator	Wiring (Output)	Load voltage		Auto switch model		Lead wire length*(m)			Pre-wired connector	Applicable load				
					DC	AC	Tie rod mounting	Band mounting	0.5 (-)	3 (L)	5 (Z)						
Reed switch	—	Grommet	Yes	3-wire (NPN)	—	5V	—	Z76	—	●	●	—	—	IC circuit			
				2-wire	24V	12V	100V	—	Z73	—	●	●	●	—	—	Relay	
							100V,200V	—	A54	—	●	●	●	—	—	PLC	
							—	—	A33	—	—	—	—	—	—	PLC	
Diagnostic indication (2-color display)	Grommet	Yes	2-wire	24V	—	—	100V,200V	—	—	—	—	—	—	Relay			
							—	—	A34	—	—	—	—	—	PLC		
Solid state switch	—	Grommet	Yes	3-wire (NPN)	24V	5V,12V	—	Y59A	—	●	●	○	○	IC circuit			
				3-wire (PNP)				Y7P	—	●	●	○	○	—	—		
				2-wire	12V	100V,200V	J51	—	●	●	○	○	—	—			
				2-wire			Y59B	—	●	●	○	○	—	—			
				Terminal conduit	Yes	3-wire (NPN)	24V	5V,12V	—	—	—	G39	—	—	—	—	IC circuit
						2-wire					—	K39	—	—	—	—	—
		Grommet	Yes	3-wire (NPN)	24V	5V,12V	—	—	Y7NW	—	●	●	○	○	IC circuit		
				3-wire (PNP)					Y7PW	—	●	●	○	○	IC circuit		
				2-wire					Y7BW	—	●	●	○	○	—		
				2-wire					Y7BA	—	—	●	○	○	—		
				4-wire (NPN)					F59F	—	●	●	○	○	IC circuit		
				2-wire					F5LF	—	●	●	○	○	—		
Water resistance (2-color display)	Grommet	Yes	2-wire	24V	12V	—	Y7BA	—	—	●	○	○	—				
Diagnostic output (2-color display)							F59F	—	●	●	○	○	IC circuit				
Latch type diagnostic output (2-color display)	Grommet	Yes	2-wire	24V	5V,12V	—	F59F	—	●	●	○	○	IC circuit				
Strong magnetic field resistance							F5LF	—	●	●	○	○	—				
				2-wire	—	—	—	P5DW	—	—	●	●	○	○	—		

* Lead wire length 0.5m..... — (Example): A54
3m..... L (Example): A54L
5m..... Z (Example): A54Z

** Solid state switches marked with a "○" are produced upon receipt of order.

• Besides the above models, there are some other auto switches that are applicable. For detailed information, please refer to page 11.



JIS Symbol
Double acting

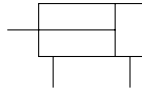

Made to Order

Refer to page 38 for made to order products of series MB.

Symbol	Specifications/Descriptions
—XA□	Change of rod end shape
—XB5	Oversized rod cylinder
—XB6	Heat resistant cylinder (150°C)
—XB13	Low speed cylinder (5 to 50mm/s)
—XC3	Special port position
—XC4	With heavy duty scraper
—XC5	Heat resistant cylinder (110°C)
—XC6	Piston rod and rod end nut made of stainless steel
—XC7	Tie rod, cushion valve, tie rod nut, etc. made of stainless steel
—XC8	Adjustable stroke cylinder/Adjustable extend stroke
—XC9	Adjustable stroke cylinder/Adjustable retract stroke
—XC10	Dual stroke cylinder/Double rod
—XC11	Dual stroke cylinder/Single rod
—XC12	Tandem cylinder
—XC14	Change of trunnion bracket mounting position
—XC22	Fluorine rubber seals
—XC27	Double clevis pin and double knuckle pin made of stainless steel
—XC29	Double knuckle joint with spring pin
—XC30	Front trunnion
—XC35	With coil scraper

Specifications

Bore size (mm)	32	40	50	63	80	100	125
Action	Double acting single rod						
Fluid	Air						
Proof pressure	1.5MPa						
Max. operating pressure	1.0MPa						
Min. operating pressure	0.05MPa						
Ambient and fluid temperature	Without auto switch: -10 to 70°C (No freezing)						
	With auto switch: -10 to 60°C (No freezing)						
Lubrication	Not required (Non-lube)						
Operating piston speed	50 to 1000mm/s						50 to 700mm/s
Allowable stroke tolerance	up to 250: $^{+1.0}_0$, 251 to 1000: $^{+1.4}_0$, 1001 to 1500: $^{+1.8}_0$						
Cushion ^{Note 1)}	Both ends (Air cushion)						
Thread tolerance	JIS class 2						
Port size (Rc, NPT, G)	1/8	1/4	1/4	3/8	3/8	1/2	1/2
Mounting	Basic, Foot, Front flange, Rear flange, Single clevis, Double clevis, Center trunnion						

Note 1) When requesting a cylinder without air cushion, cylinder utilizes rubber bumpers which increases cylinders overall length.

Standard Stroke

Bore (mm)	Standard stroke (mm)	Max. stroke
32	25, 50, 75, 100, 125, 150, 175, 200, 250, 300, 350, 400, 450, 500	700
40	25, 50, 75, 100, 125, 150, 175, 200, 250, 300, 350, 400, 450, 500	800
50	25, 50, 75, 100, 125, 150, 175, 200, 250, 300, 350, 400, 450, 500, 600	1200
63	25, 50, 75, 100, 125, 150, 175, 200, 250, 300, 350, 400, 450, 500, 600	1200
80	25, 50, 75, 100, 125, 150, 175, 200, 250, 300, 350, 400, 450, 500, 600, 700, 800	1400
100	25, 50, 75, 100, 125, 150, 175, 200, 250, 300, 350, 400, 450, 500, 600, 700, 800	1500
125	25, 50, 75, 100, 125, 150, 175, 200, 250, 300, 350, 400, 450, 500, 600, 700, 800	1500

Intermediate strokes are available. (No spacer is used.)

Accessories

Mounting		Basic	Foot	Front flange	Rear flange	Single clevis	Double clevis	Center trunnion
Standard	Rod end nut	●	●	●	●	●	●	●
	Clevis pin	—	—	—	—	—	●	—
Option	Single knuckle joint	●	●	●	●	●	●	●
	Double knuckle joint (with pin)	●	●	●	●	●	●	●
	Rod boot	●	●	●	●	●	●	●

Material of Rod Boot

Symbol	Material	Max. ambient temp.
J	Nylon tarpaulin	70°C
K	Heat resistant tarpaulin	110°C *

* Max. ambient temperature for rod boot itself.

Mounting Bracket Part No.

Bore size (mm)	32	40	50	63	80	100	125
Foot ^{Note 1)}	MB-L03	MB-L04	MB-L05	MB-L06	MB-L08	MB-L10	MB-L12
Flange	MB-F03	MB-F04	MB-F05	MB-F06	MB-F08	MB-F10	MB-F12
Single clevis	MB-C03	MB-C04	MB-C05	MB-C06	MB-C08	MB-C10	MB-C12
Double clevis	MB-D03	MB-D04	MB-D05	MB-D06	MB-D08	MB-D10	MB-D12

Note 1) Two foot brackets required for one cylinder.

Note 2) Accessories for each mounting bracket are as follows.

Foot, Flange, Single clevis: Mounting bolts

Double clevis: Clevis pin, Cotter pin → Refer to page 8 for details.

Series MB

Theoretical Force

(Unit: N) OUT IN

Bore size (mm)	Rod diameter (mm)	Operating direction	Piston area (mm ²)	Operating pressure (MPa)								
				0.2	0.3	0.4	0.5	0.6	0.7	0.8	0.9	1.0
32	12	OUT	804	161	241	322	402	482	563	643	724	804
		IN	691	138	207	276	346	415	484	553	622	691
40	16	OUT	1257	251	377	503	629	754	880	1006	1131	1257
		IN	1056	211	317	422	528	634	739	845	950	1056
50	20	OUT	1963	393	589	785	982	1178	1374	1570	1767	1963
		IN	1649	330	495	660	825	989	1154	1319	1484	1649
63	20	OUT	3117	623	935	1247	1559	1870	2182	2494	2805	3117
		IN	2803	561	841	1121	1402	1682	1962	2242	2523	2803
80	25	OUT	5027	1005	1508	2011	2514	3016	3519	4022	4524	5027
		IN	4536	907	1361	1814	2268	2722	3175	3629	4082	4536
100	30	OUT	7854	1571	2356	3142	3927	4712	5498	6283	7069	7854
		IN	7147	1429	2144	2859	3574	4288	5003	5718	6432	7147
125	32	OUT	12272	2454	3682	4909	6136	7363	8590	9818	11045	12272
		IN	11468	2294	3440	4588	5734	6881	8028	9174	10321	11468

(Note) Theoretical force (N)=Pressure (MPa) X Piston area (mm²)

Allowable Kinetic Energy

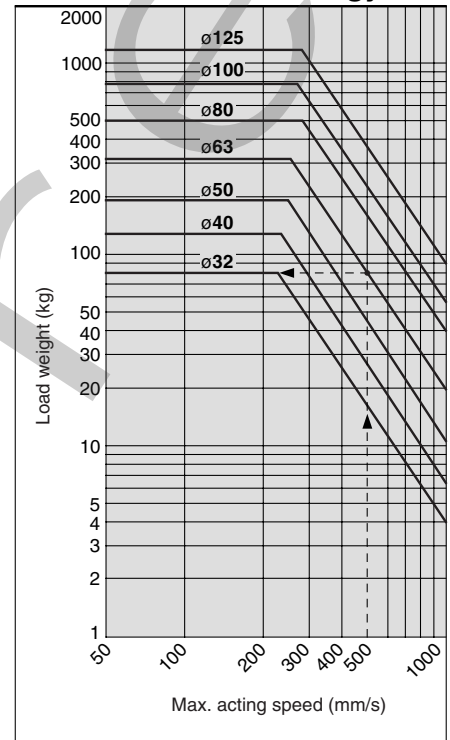

Example: Load limit at rod end when air cylinder ø63 is actuated with max. acting speed 500mm/s. See the intersection of lateral axis 500mm/s and ø63 line, and extend the intersection to left. Thus the allowable load is 80kg.

Weight/Aluminum Tube

(kg)

Bore size (mm)		32	40	50	63	80	100	125
Basic weight	Basic	0.50	0.69	1.19	1.47	2.73	3.70	5.48
	Foot	0.62	0.83	1.41	1.75	3.23	4.36	7.56
	Flange	0.79	1.06	1.64	2.26	4.18	7.01	9.64
	Single clevis	0.75	0.92	1.53	2.10	3.84	6.87	8.05
	Double clevis	0.76	0.96	1.62	2.26	4.13	7.39	8.25
	Trunnion	0.79	1.05	1.67	2.27	4.28	7.37	8.46
Additional weight per 50 stroke	All mounting bracket	0.11	0.16	0.26	0.27	0.42	0.56	0.71
Accessories	Single knuckle joint	0.15	0.23	0.26	0.26	0.60	0.83	1.10
	Double knuckle joint (with pin)	0.22	0.37	0.43	0.43	0.87	1.27	0.91
Square tube	Additional weight to the basic weight*	0.03	0.03	0.05	0.07	0.11	0.13	—
	Additional weight per 50 stroke	0.16	0.21	0.33	0.37	0.56	0.72	—

Calculation example: **MBB32-100** (Basic, ø32, 100st)

- Basic weight 0.50 (Basic, ø32)
 - Additional weight ... 0.11/50 stroke
 - Cylinder stroke 100 stroke
- 0.50+0.11X100/50=0.72kg

Auto Switch Mounting Bracket Part No.

(mm)

Auto switch model	Bore size						
	32	40	50	63	80	100	125
D-A3□/A44 D-G39/K39	BMB2-032	BMB2-040	BMB1-050	BMB1-063	BMB1-080	BMB1-100	BS1-125
D-A5□/A6□ D-A59W D-F5□/J5□ D-F5□W/J59W D-F5□F D-F5BAL D-F5NTL	BT-03	BT-03	BT-05	BT-05	BT-06	BT-06	BT-08
D-P5DWL	BMB3T-040	BMB3T-040	BMB3T-050	BMB3T-050	BMB3T-080	BMB3T-080	BAP2T-080
D-Z7□/Z80 D-Y59□/Y69□ D-Y7P/Y7PV D-Y7□W D-Y7□WV D-Y7BAL	BMB4-032	BMB4-032	BMB4-050	BMB4-050	BA4-063	BA4-063	BA4-080

[A set of stainless steel mounting screws]
A set of following stainless steel mounting screws is attached. (A mounting bracket itself is not attached. Please order it separately.)

BBA1: D-A5/A6/F5/J5 types
*D-F5BAL" switch is set on the cylinder with the screws above when shipped. When a switch only is shipped, "BBA1" screws are attached.

Construction

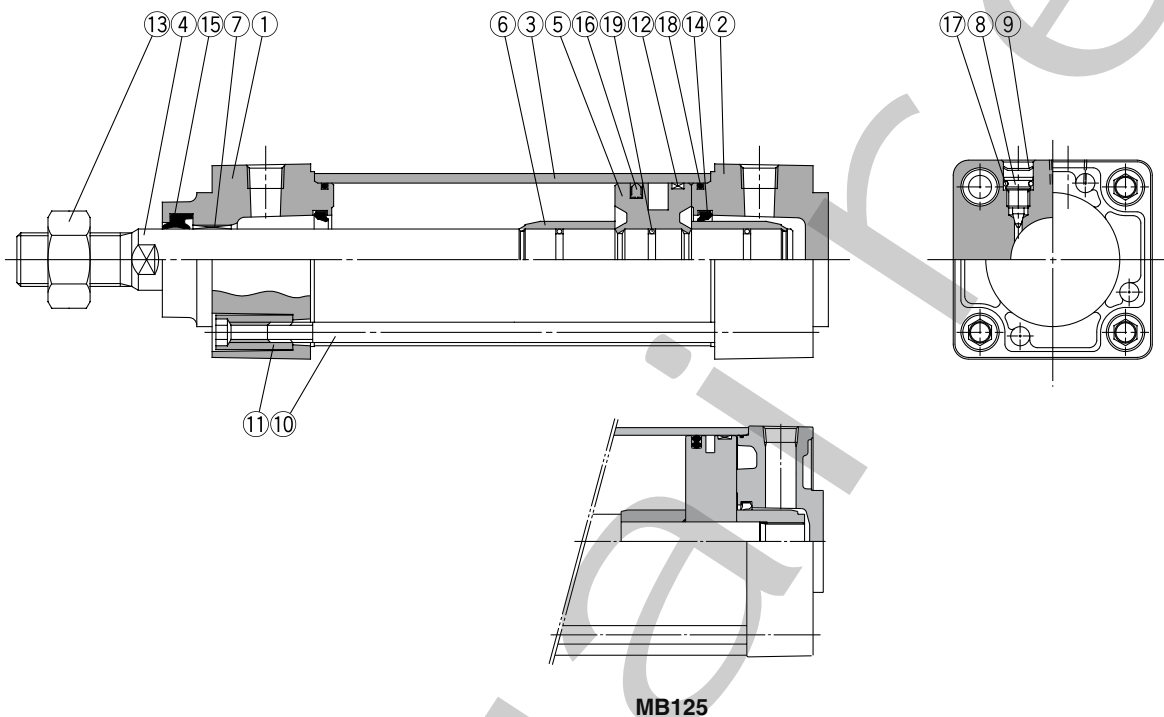

Component Parts

No.	Description	Material	Note
1	Rod cover	Aluminum die-cast	Metallic painted
2	Head cover	Aluminum die-cast	Metallic painted
3	Cylinder tube	Aluminum alloy	Hard anodized
4	Piston rod	Carbon steel	Hard chrome plated
5	Piston	Aluminum alloy	Chromated
6	Cushion ring	Brass	
7	Bushing	Lead bronze cast	
8	Cushion ring	Steel wire	Nickel plated
9	Snap ring	Steel for spring	ø40 to ø100
10	Tie rod	Carbon steel	Uni-chromated
11	Tie rod nut	Carbon steel	Nickel plated
12	Wear ring	Resin	
13	Rod end nut	Carbon steel	Nickel plated

No.	Description	Material	Note
14*	Cushion seal	Urethane	
15*	Rod seal	NBR	
16*	Piston seal	NBR	
17	Cushion valve seal	NBR	
18*	Cylinder tube gasket	NBR	
19	Piston gasket	NBR	

Copper-free air cylinder

20 – MB

↓ Copper-free

Copper material has been replaced with non-copper material to prevent generation of copper ions. This is to eliminate influence of copper ions and fluoro-resin upon color CRT.

Replacement Parts: Seal Kit

Bore size (mm)	Kit No.	Contents
32	MB32-PS	Set of the No. 14, 15, 16 and 18
40	MB40-PS	
50	MB50-PS	
63	MB63-PS	
80	MB80-PS	
100	MB100-PS	
125	MB125-PS	

* Seal kits consist of items 14, 15, 16 and 18, and can be ordered by using the seal kit number corresponding to each bore size.

Water resistant air cylinder

Water resistant air cylinders are also available in Series MB, which are suitable for use on machine tools, where exposure to coolant is possible and applicable for food machinery and automobile washing equipment in an environment where water splashes. Please consult P/A for more information.

Specifications

Action	Double acting single rod
Bore size	ø32, ø40, ø50, ø63, ø80, ø100
Max. operating pressure	1MPa
Min. operating pressure	0.05MPa
Cushion	Air cushion <small>Note 1)</small>
Piping	Screw-in piping
Operating piston speed	50 to 1000mm/s
Mounting bracket	Basic, Axial foot, Front flange, Rear flange, Single clevis, Double clevis, Center trunnion

*Auto switch capable.

★ The cylinder should be operated within its allowable kinetic energy. (Refer to page 3.)
Note 1) In case of types with no air cushion, a rubber bumper is used.

With Mounting Bracket

Front flange/(F)

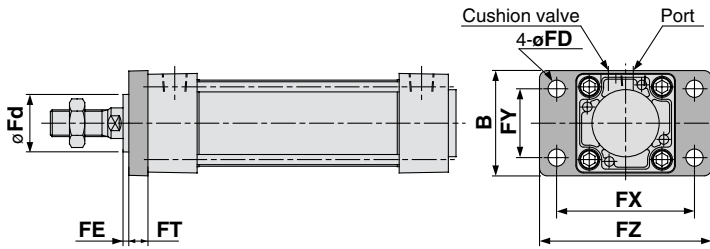

Front flange

Bore size (mm)	Stroke range	B	FD	FE	FT	FX	FY	FZ	Fd
32	to 700	50	7	3	10	64	32	79	25
40	to 800	55	9	3	10	72	36	90	31
50	to 1000	70	9	2	12	90	45	110	38.5
63	to 1000	80	9	2	12	100	50	120	39.5
80	to 1000	100	12	4	16	126	63	153	45.5
100	to 1000	120	14	4	16	150	75	178	54
125	to 1400	138	14	7	20	180	102	216	57.5

Without air cushion

Bore size (mm)	ZZ
32	147
40	151
50, 63	172
80, 100	212
125	249

Rear flange/(G)

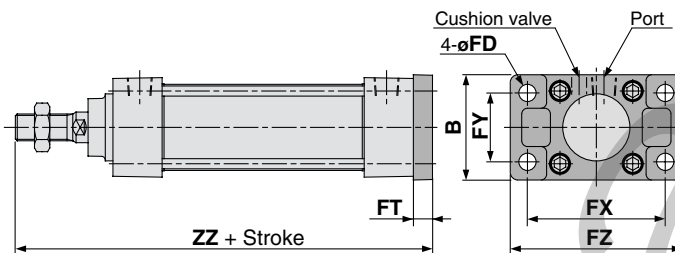

Rear flange

Bore size (mm)	Stroke range	B	FD	FT	FX	FY	FZ	ZZ*
32	to 500	50	7	10	64	32	79	141
40	to 500	55	9	10	72	36	90	145
50	to 600	70	9	12	90	45	110	164
63	to 600	80	9	12	100	50	120	164
80	to 800	100	12	16	126	63	153	202
100	to 800	120	14	16	150	75	178	202
125	to 1000	138	14	20	180	102	216	237

Without air cushion

Bore size (mm)	Z	ZZ
32	160	170.5
40	164	175
50, 63	190	205
80, 100	238	261
125	279	307

Single clevis/(C)

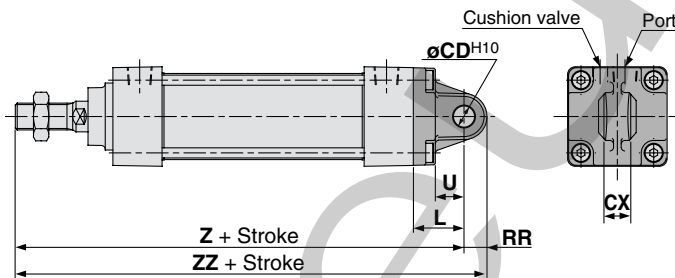

Single clevis

Bore size (mm)	Stroke range	L	RR	U	CD ^{H10}	CX ^{-0.1/-0.3}	Z*	ZZ*
32	to 500	23	10.5	13	10	14	154	164.5
40	to 500	23	11	13	10	14	158	169
50	to 600	30	15	17	14	20	182	197
63	to 600	30	15	17	14	20	182	197
80	to 800	42	23	26	22	30	228	251
100	to 800	42	23	26	22	30	228	251
125	to 1000	50	28	30	25	32	267	295

*** Front/Rear flange, Single/Double clevis**

Model without air cushion is designed to include rubber bumpers. The overall length is longer than the cylinder with air cushion as follows because the bumpers are attached to the both sides of the piston; ø32, ø40: +6mm, ø50, ø63: +8mm, ø80, ø100: +10mm, ø125: +12mm

Without air cushion

Bore size (mm)	Z	ZZ
32	160	170.5
40	164	175
50, 63	190	205
80, 100	238	261
125	279	307

Double clevis/(D)

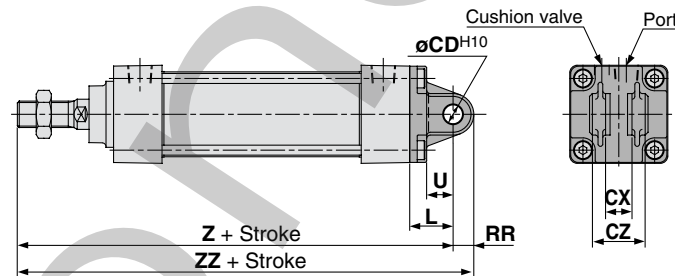

Double clevis

Bore size (mm)	Stroke range	L	RR	U	CD ^{H10}	CX ^{+0.1}	CZ	Z*	ZZ*
32	to 500	23	10.5	13	10	14	28	154	164.5
40	to 500	23	11	13	10	14	28	158	169
50	to 600	30	15	17	14	20	40	182	197
63	to 600	30	15	17	14	20	40	182	197
80	to 800	42	23	26	22	30	60	228	251
100	to 800	42	23	26	22	30	60	228	251
125	to 1000	50	28	30	25	32	64	267	295

****Center trunnion**

Model without air cushion is designed to include rubber bumpers. The overall length is longer than the cylinder with air cushion as follows because the bumpers are attached to the both sides of the piston; ø32, ø40: +3mm, ø50, ø63: +4mm, ø80, ø100: +5mm, ø125: +6mm

Without air cushion

Bore size (mm)	Z
32	92
40	96
50, 63	109
80, 100	134
125	163

Center trunnion/(T)

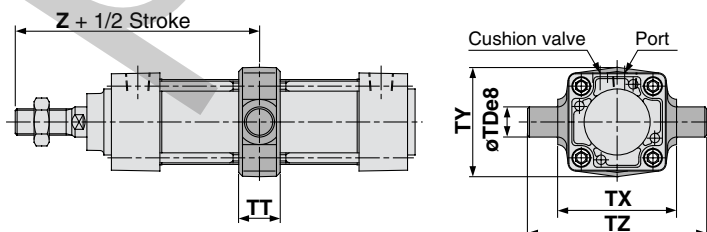

Center trunnion

Bore size (mm)	Stroke range	TDe8	TT	TX	TY	TZ	Z**
32	to 500	12	17	50	49	74	89
40	to 500	16	22	63	58	95	93
50	to 600	16	22	75	71	107	105
63	to 600	20	28	90	87	130	105
80	to 800	20	34	110	110	150	129
100	to 800	25	40	132	136	182	129
125	to 1000	25	50	160	160	210	157

Series MB

Trunnion/Double Clevis Pivot Bracket

Part No.

Cylinder model	MB□32	MB□40	MB□50	MB□63	MB□80	MB□100	MB□125
Description							
Trunnion pivot bracket Note 1)	MB-S03	MB-S04		MB-S06		MB-S10	MB-S12
Double clevis pivot bracket	MB-B03		MB-B05		MB-B08		MB-B12

Note 1) When ordering a trunnion pivot bracket, order 2 pcs. for 1 cylinder.

Trunnion pivot bracket

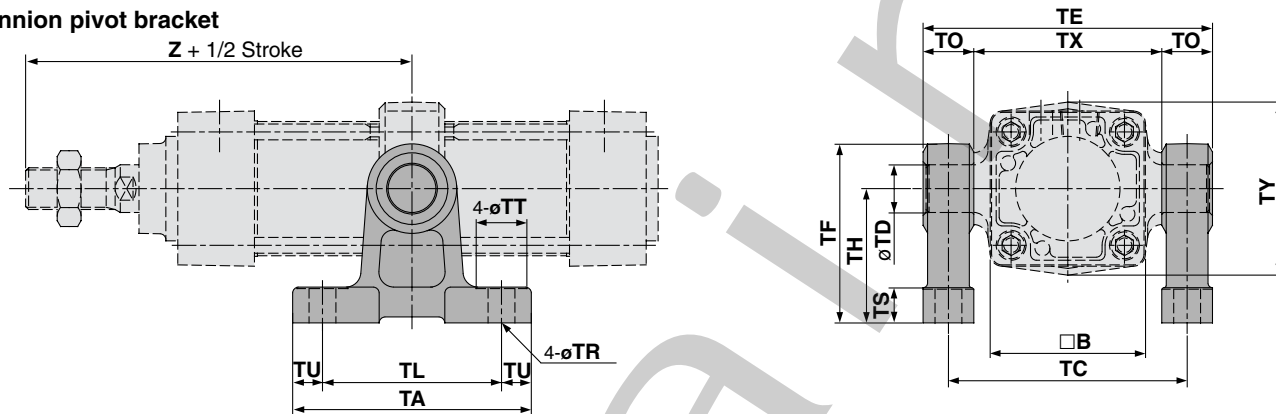

(mm)

Part No.	Bore size (mm)	B	TA	TL	TU	TC	TX	TE	TO	TR	TT	TS	TH	TF	Z**	TDH10
MB-S03	32	46	62	45	8.5	62	50	74	12	7	13	10	35	47	89	12 ^{+0.070} ₀
MB-S04	40	52	80	60	10	80	63	97	17	9	17	12	45	60	93	16 ^{+0.070} ₀
	50	65	80	60	10	92	75	109	17	9	17	12	45	60	105	16 ^{+0.070} ₀
MB-S06	63	75	100	70	15	110	90	130	20	11	22	14	60	80	105	20 ^{+0.084} ₀
	80	95	100	70	15	130	110	150	20	11	22	14	60	80	129	20 ^{+0.084} ₀
MB-S10	100	114	120	90	15	158	132	184	26	13.5	24	17	75	100	129	25 ^{+0.084} ₀
MB-S12	125	136	142	105	18.5	186	160	212	26	13.5	24	25	85	115	157	25 ^{+0.084} ₀

Without air cushion

Bore size (mm)	Z
32	92
40	96
50	109
63	109
80	134
100	134
125	163

Double clevis pivot bracket

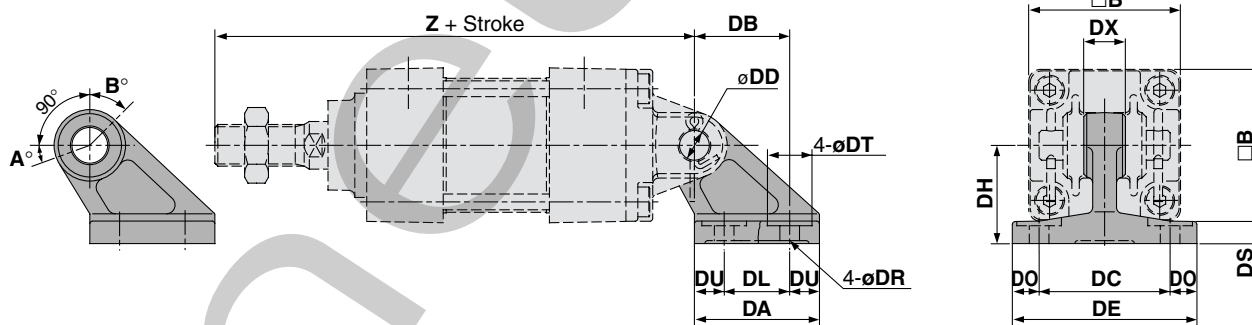

(mm)

Part No.	Bore size (mm)	B	DA	DB	DL	DU	DC	DX	DE	DO	DR	DT	DS	DH	Z*	DDH10
MB-B03	32	46	42	32	22	10	44	14	62	9	6.6	15	7	33	154	10 ^{+0.058} ₀
	40	52	42	32	22	10	44	14	62	9	6.6	15	7	33	158	10 ^{+0.058} ₀
MB-B05	50	65	53	43	30	11.5	60	20	81	10.5	9	18	8	45	182	14 ^{+0.070} ₀
	63	75	53	43	30	11.5	60	20	81	10.5	9	18	8	45	182	14 ^{+0.070} ₀
MB-B08	80	95	73	64	45	14	86	30	111	12.5	11	22	10	65	228	22 ^{+0.084} ₀
	100	114	73	64	45	14	86	30	111	12.5	11	22	10	65	228	22 ^{+0.084} ₀
MB-B12	125	136	90	78	60	15	110	32	136	13	13.5	24	14	75	267	25 ^{+0.084} ₀

Without air cushion

Bore size (mm)	Z
32	160
40	164
50	190
63	190
80	238
100	238
125	279

Rotating angle

Bore size (mm)	A°	B°	A°+B°+90°
32, 40	25°	45°	160°
50, 63	40°	60°	190°
80, 100	30°	55°	175°
125	30°	50°	170°

* Mounting plate

Model without air cushion is designed to include rubber bumpers. The overall length is longer than the cylinder with air cushion as follows because the bumpers are attached to the both sides of the piston; ø32, ø40: +6mm, ø50, ø63: +8mm, ø80, ø100: +10mm, ø125: +12mm

** Trunnion pivot bracket

Model without air cushion is designed to include rubber bumpers. The overall length is longer than the cylinder with air cushion as follows because the bumpers are attached to the both sides of the piston; ø32, ø40: +3mm, ø50, ø63: +4mm, ø80, ø100: +5mm, ø125: +6mm

Dimensions for Accessories

Rod end nut (Standard)

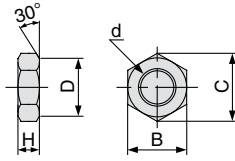

Part No.	Bore size (mm)	d	H	B	C	D
NT-03	32	M10 X 1.25	6	17	19.6	16.5
NT-04	40	M14 X 1.5	8	22	25.4	21
NT-05	50, 63	M18 X 1.5	11	27	31.2	26
NT-08	80	M22 X 1.5	13	32	37.0	31
NT-10	100	M26 X 1.5	16	41	47.3	39
NT-12M	125	M27 X 2.0	16	41	47.3	39

Knuckle joint pin Clevis pin

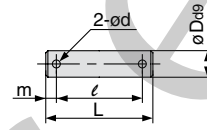

Part No.	Bore size (mm)		D _ø	L	l	m	d (Through hole diameter)	Note 1)
	Clevis	Knuckle						
CD-M03	32, 40		10 ^{+0.040} _{-0.076}	44	36	4	3	ø3 X 18 ℓ
CD-M05	50, 63		14 ^{+0.050} _{-0.093}	60	51	4.5	4	ø4 X 25 ℓ
CD-M08	80, 100		22 ^{+0.065} _{-0.117}	82	72	5	4	ø4 X 35 ℓ
IY-12	125		25 ^{+0.065} _{-0.117}	79.5	69.5	5	4	ø4 X 40 ℓ

Note 1) When using cotter pin, flat washer is used together.

I type Single knuckle joint

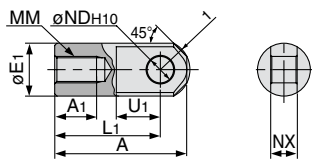

Part No.	Bore size (mm)	A	A ₁	E ₁	L ₁	MM	R ₁	U ₁	NDH ₁₀	NX
I-03M	32	40	14	20	30	M10 X 1.25	12	16	10 ^{+0.058} ₀	14 ^{-0.10} _{-0.30}
I-04M	40	50	19	22	40	M14 X 1.5	12.5	19	10 ^{+0.058} ₀	14 ^{-0.10} _{-0.30}
I-05M	50, 63	64	24	28	50	M18 X 1.5	16.5	24	14 ^{+0.070} ₀	20 ^{-0.10} _{-0.30}
I-08M	80	80	26	40	60	M22 X 1.5	23.5	34	22 ^{+0.084} ₀	30 ^{-0.10} _{-0.30}
I-10M	100	80	26	40	60	M26 X 1.5	23.5	34	22 ^{+0.084} ₀	30 ^{-0.10} _{-0.30}
I-12M	125	119	36	46	92	M27 X 2.0	28.5	34	25 ^{+0.084} ₀	32 ^{-0.10} _{-0.30}

Y type Double knuckle joint

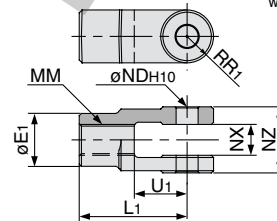

Part No.	Bore size (mm)	E ₁	L ₁	MM	R ₁	U ₁	NDH ₁₀	NX	NZ
Y-03M	32	20	30	M10 X 1.25	10	16	10 ^{+0.058} ₀	14 ^{+0.30} _{+0.10}	28 ^{-0.10} _{-0.30}
Y-04M	40	22	40	M14 X 1.5	11	19	10 ^{+0.058} ₀	14 ^{+0.30} _{+0.10}	28 ^{-0.10} _{-0.30}
Y-05M	50, 63	28	50	M18 X 1.5	14	24	14 ^{+0.070} ₀	20 ^{+0.30} _{+0.10}	40 ^{-0.10} _{-0.30}
Y-08M	80	40	65	M22 X 1.5	20	34	22 ^{+0.084} ₀	30 ^{+0.30} _{+0.10}	60 ^{-0.10} _{-0.30}
Y-10M	100	40	65	M26 X 1.5	20	34	22 ^{+0.084} ₀	30 ^{+0.30} _{+0.10}	60 ^{-0.10} _{-0.30}
Y-12M	125	46	100	M27 X 2	27	42	25 ^{+0.084} ₀	32 ^{+0.30} _{+0.10}	64 ^{-0.10} _{-0.30}

Note) For a double clevis, a pin (cotter pin) and a flat washer are equipped as standard.

Combinations of Support Brackets

Available combinations Refer to below picture together.

Bracket for cylinder	Bracket for work	Single clevis	Double clevis	Single knuckle joint	Double knuckle joint	Pivot bracket
Single clevis		-	①	-	②	-
Double clevis		③	-	④	-	⑨
Single knuckle joint		-	⑤	-	⑥	-
Double knuckle joint		⑦	-	⑧	-	⑩

No.	Appearance	No.	Appearance
①	Single clevis + Double clevis	⑥	Single knuckle joint + Double knuckle joint
②	Single clevis + Double knuckle joint	⑦	Double knuckle joint + Single clevis
③	Double clevis + Single clevis	⑧	Double knuckle joint + Single knuckle joint
④	Double clevis + Single knuckle joint	⑨	Double clevis + Pivot bracket
⑤	Single knuckle joint + Double clevis	⑩	Double knuckle joint + Pivot bracket

Series MB

Auto Switch Mounting Position/Mounting Height

Band mounting

D-A3□/G39/K39

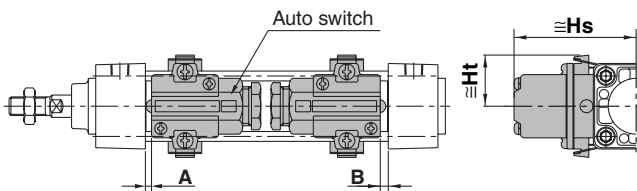

D-A44

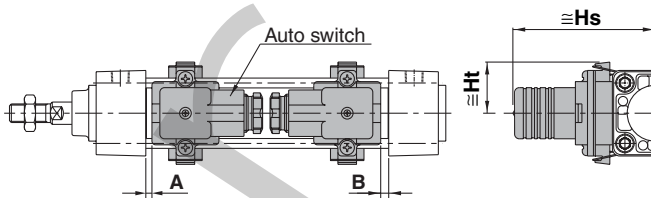

Tie Rod Mounting

D-F5□/J5□

D-F5□W/J59W/F5BAL

D-F5□F/F5NTL

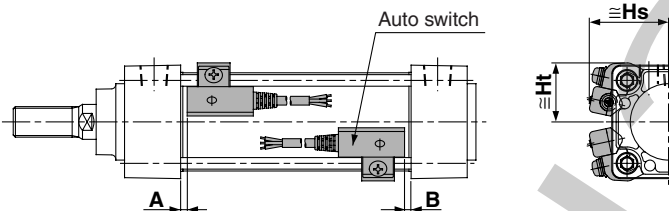

D-A5□/A6□

D-A59W

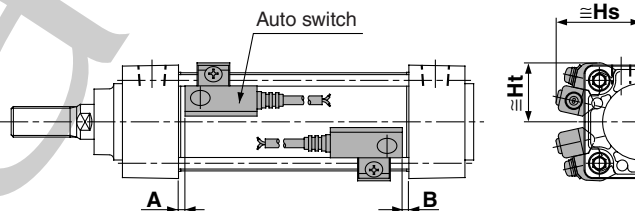

D-Z7□/Z80

D-Y59□/Y69□/Y7P/Y7PV

D-Y7□W/Y7□WV/Y7BAL

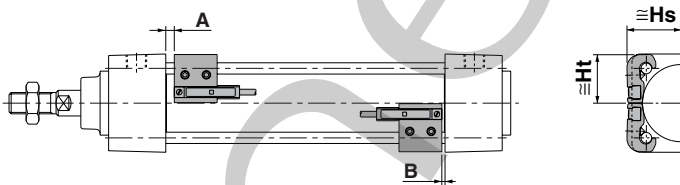

D-P5DWL

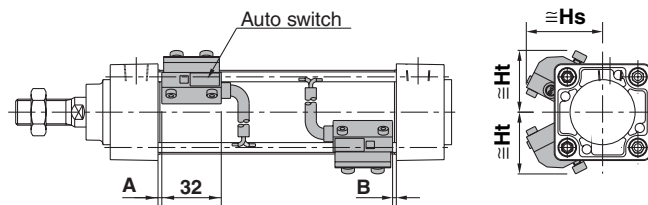

Auto Switch Mounting Position/Mounting Height

Auto Switch Mounting Position

(mm)

Bore size (mm)	D-A5□ D-A6□		D-A59W		D-F5□W D-J59W D-F5□ D-J5□ D-F5BAL D-F59F		D-F5LF		D-F5NTL		D-A3□ D-A44 D-G39 D-K39		D-Z7□, Z80 D-Y59□, Y69□ D-Y7P, Y7PV D-Y7□W, D-Y7□WV D-Y7BAL		D-P5DWL	
	A	B	A	B	A	B	A	B	A	B	A	B	A	B	A	B
32	0.5	0	4.5	2	7	4.5	11	8.5	12	9.5	0.5	0	4	1.5	3.5	1
40	0.5	0	4.5	2	7	4.5	11	8.5	12	9.5	0.5	0	4	1.5	3.5	1
50	1	0	5	2.5	7.5	5	11.5	9	12.5	10	1	0	4.5	2	4	1.5
63	1	0	5	2.5	7.5	5	11.5	9	12.5	10	1	0	4.5	2	4	1.5
80	4	2.5	8	6.5	10.5	9	14.5	13	15.5	14	4	2.5	7.5	6	7	5.5
100	4	2.5	8	6.5	10.5	9	14.5	13	15.5	14	4	2.5	7.5	6	7	5.5
125	6	6	10	10	12.5	12.5	16.5	16.5	17.5	17.5	6	6	9.5	9.5	9	9

* Types without air cushion have different values for auto switch mounting positions. Add the following values to values A and B each.
3 mm (ø32 and ø40), 4 mm (ø50 and ø63), 5 mm (ø80 and ø100) and 6 mm (ø125).

Auto Switch Mounting Height

(mm)

Bore size (mm)	D-A5□ D-A6□ D-A59W		D-F5□, D-J5□ D-F5□F D-F5□W, D-J59W D-F5BAL, D-F5NTL		D-A3□ D-G39 D-K39		D-A44		D-Z7□, Z-80 D-Y59□ D-Y7P D-Y7□W		D-Y69□ D-Y7PV D-Y7□WV		D-Y7BAL		D-P5DWL	
	Hs	Ht	Hs	Ht	Hs	Ht	Hs	Ht	Hs	Ht	Hs	Ht	Hs	Ht	Hs	Ht
32	35	24.5	32.5	25	67	27.5	77	27.5	25.5	23	26.5	23	30	23	38	31
40	38.5	27.5	36.5	27.5	71.5	27.5	81.5	27.5	29.5	26	30	26	34	26	42	33
50	43.5	34.5	41	34	77	—	87	—	33.5	31	34.5	31	38	31	46.5	39
63	48.5	39.5	46	39	83.5	—	93.5	—	39	36	40	36	43	36	51.5	44
80	55	46.5	52.5	46.5	92.5	—	103	—	47.5	45	48.5	45	52	45	58	51.5
100	62	55	59.5	55	103	—	113.5	—	55.5	53.5	56.5	53.5	60	53.5	65.5	60.5
125	71.5	66.5	70.5	66.5	115	—	125	—	67.5	65	68.5	65	72	65	76.5	72

Operating range

(mm)

Auto Switch type	Bore size						
	32	40	50	63	80	100	125
D-Z7□, Z80	7.5	8.5	7.5	9.5	9.5	10.5	13
D-A5□, A6□	9	9	10	11	11	11	10
D-A59W	13	13	13	14	14	15	17
D-A3□, A44	9	9	10	11	11	11	10
D-Y59□, Y69□ D-Y7P, Y7□V D-Y7□W, Y7□WV	5.5	5.5	7	7.5	6.5	5.5	7
D-Y7BAL	3.5	3.5	3.5	4	4.5	5	6
D-F5□, J5□ D-F5□W, J59W D-F5BAL, F5NTL D-F59F	3.5	4	4	4.5	4.5	4.5	5
D-F5LF	5	5.5	5.5	6	6	6	6
D-G39, K39	9	9	9	10	10	11	11
D-P5DWL	4	4	4	4.5	4	4.5	4.5

* These values are given as guidelines including the hysteresis and are not guaranteed. They may vary significantly depending on the environment (with ±30% variations).

Series MB

Minimum Strokes for Auto Switch Mounting

Auto switch model	No. of auto switches	Center trunnion (mm)					
		ø32	ø40	ø50	ø63	ø80	ø100
D-A3 □ D-G39 D-K39	2 (different side)	60	65	75	80	85	90
	2 (same side)	90	95	100	105	110	125
	n (different side) n = 2,4,6,8...	60 + 30 (n-2) n = 2,4,6,8...	65 + 30 (n-2) n = 2,4,6,8...	75 + 30 (n-2) n = 2,4,6,8...	80 + 30 (n-2) n = 2,4,6,8...	85 + 30 (n-2) n = 2,4,6,8...	90 + 30 (n-2) n = 2,4,6,8...
	n (same side) n = 2,4,6,8...	90 + 100 (n-2) n = 2,4,6,8...	95 + 100 (n-2) n = 2,4,6,8...	100 + 100 (n-2) n = 2,4,6,8...	105 + 100 (n-2) n = 2,4,6,8...	110 + 100 (n-2) n = 2,4,6,8...	125 + 100 (n-2) n = 2,4,6,8...
D-A44	1	60	65	75	80	85	90
	2 (different side)	70	75	80	85	90	
	2 (same side)	70	75	80	85	90	
	n (different side) n = 2,4,6,8...	70 + 30 (n-2) n = 2,4,6,8...	75 + 30 (n-2) n = 2,4,6,8...	80 + 30 (n-2) n = 2,4,6,8...	85 + 30 (n-2) n = 2,4,6,8...	90 + 30 (n-2) n = 2,4,6,8...	
D-A5 □ D-A6 □	n (same side)	70 + 50 (n-2) n = 2,4,6,8...	75 + 50 (n-2) n = 2,4,6,8...	80 + 50 (n-2) n = 2,4,6,8...	85 + 50 (n-2) n = 2,4,6,8...	90 + 50 (n-2) n = 2,4,6,8...	
	1	70	75	80	85	90	
D-A59W	2 (different side or same side)	60	70	85	110	115	120
	n (same side) n = 4,8,12,16...	60 + 55 $\frac{(n-4)}{2}$ n = 4,8,12,16...	70 + 55 $\frac{(n-4)}{2}$ n = 4,8,12,16...	85 + 55 $\frac{(n-4)}{2}$ n = 4,8,12,16...	110 + 55 $\frac{(n-4)}{2}$ n = 4,8,12,16...	115 + 55 $\frac{(n-4)}{2}$ n = 4,8,12,16...	120 + 55 $\frac{(n-4)}{2}$ n = 4,8,12,16...
	1	60	70	85	110	115	120
D-F5 □ D-J5 □ D-F5 □ W D-J59W D-F5BAL D-F59F	2 (different side or same side)	90	95	110	115	120	130
	n (same side) n = 4,8,12,16...	90 + 55 $\frac{(n-4)}{2}$ n = 4,8,12,16...	95 + 55 $\frac{(n-4)}{2}$ n = 4,8,12,16...	110 + 55 $\frac{(n-4)}{2}$ n = 4,8,12,16...	115 + 55 $\frac{(n-4)}{2}$ n = 4,8,12,16...	120 + 55 $\frac{(n-4)}{2}$ n = 4,8,12,16...	130 + 55 $\frac{(n-4)}{2}$ n = 4,8,12,16...
	1	90	95	110	115	120	130
D-F5NTL D-F5LF	2 (different side or same side)	100	105	120	125	130	140
	n (same side) n = 4,8,12,16...	100 + 55 $\frac{(n-4)}{2}$ n = 4,8,12,16...	105 + 55 $\frac{(n-4)}{2}$ n = 4,8,12,16...	120 + 55 $\frac{(n-4)}{2}$ n = 4,8,12,16...	125 + 55 $\frac{(n-4)}{2}$ n = 4,8,12,16...	130 + 55 $\frac{(n-4)}{2}$ n = 4,8,12,16...	140 + 55 $\frac{(n-4)}{2}$ n = 4,8,12,16...
D-Z7 □ D-Z80 D-Y59 □ D-Y7P D-Y7 □ W	2 (different side or same side)	80	85	90	95	100	105
	n	80 + 40 $\frac{(n-4)}{2}$ n = 4,8,12,16...	85 + 40 $\frac{(n-4)}{2}$ n = 4,8,12,16...	90 + 40 $\frac{(n-4)}{2}$ n = 4,8,12,16...	95 + 40 $\frac{(n-4)}{2}$ n = 4,8,12,16...	100 + 40 $\frac{(n-4)}{2}$ n = 4,8,12,16...	105 + 40 $\frac{(n-4)}{2}$ n = 4,8,12,16...
	1	80	85	90	95	100	105
D-Y69 □ D-Y7PV D-Y7 □ WV	2 (different side or same side)	60	65	70	75	85	85
	n	60 + 30 $\frac{(n-4)}{2}$ n = 4,8,12,16...	65 + 30 $\frac{(n-4)}{2}$ n = 4,8,12,16...	70 + 30 $\frac{(n-4)}{2}$ n = 4,8,12,16...	75 + 30 $\frac{(n-4)}{2}$ n = 4,8,12,16...	85 + 30 $\frac{(n-4)}{2}$ n = 4,8,12,16...	85 + 30 $\frac{(n-4)}{2}$ n = 4,8,12,16...
D-Y7BAL	2 (different side or same side)	85	90	100	105	110	115
	n	85 + 45 $\frac{(n-4)}{2}$ n = 4,8,12,16...	90 + 45 $\frac{(n-4)}{2}$ n = 4,8,12,16...	100 + 45 $\frac{(n-4)}{2}$ n = 4,8,12,16...	105 + 45 $\frac{(n-4)}{2}$ n = 4,8,12,16...	110 + 45 $\frac{(n-4)}{2}$ n = 4,8,12,16...	115 + 45 $\frac{(n-4)}{2}$ n = 4,8,12,16...
D-P5DWL	2 (different side or same side)	120	130	140	150		
	n	120 + 65 $\frac{(n-4)}{2}$ n = 4,8,12,16...	130 + 65 $\frac{(n-4)}{2}$ n = 4,8,12,16...	140 + 65 $\frac{(n-4)}{2}$ n = 4,8,12,16...	150 + 65 $\frac{(n-4)}{2}$ n = 4,8,12,16...		

Besides the applicable auto switches listed in How to Order, the following auto switches can be used. For detailed specifications, please refer to Best Pneumatics Vol. 2 page 5.3-2.

Style	Auto switch model	Electrical entry (Direction)	Feature
Reed switch	D-A53,A56	Grommet (In-line)	—
	D-A64,A67		Without indicator light
	D-Z80		
Solid state switch	D-F59,F5P,J59	Grommet (In-line)	—
	D-F59W,F5PW,J59W		2-color display
	D-F5BAL		2-color display, Water resistance
	D-F5NTL	Timer	
	D-Y69A,Y69B,Y7PV	Grommet (Perpendicular)	—
D-Y7NWV,Y7PWV,Y7BWV		2-color display	

Auto switch model	No. of auto switches	Support bracket except center trunnion (mm)		
		ø32,ø40,ø50,ø63	ø80,ø100	ø125
D-A3 □ D-G39 D-K39	2 (different side)	35		
	2 (same side)	100		
	n (different side)	35 + 30 (n-2) n = 2,3,4...		
	n (same side)	100 + 100 (n-2) n = 2,3,4...		
D-A44	1	10		
	2 (different side)	35		
	2 (same side)	55		
	n (different side)	35 + 30 (n-2) n = 2,3,4...		
	n (same side)	55 + 50 (n-2) n = 2,3,4...		
D-A5 □ D-A6 □	2 (different side or same side) 1	15	20	20
	n (same side)	$15 + 55 \frac{(n-2)}{2}$ n = 2,4,6,8...	$20 + 55 \frac{(n-2)}{2}$ n = 2,4,6,8...	$20 + 55 \frac{(n-2)}{2}$ n = 2,4,6,8...
D-A59W	2 (different side or same side)	20	25	25
	n (same side)	$20 + 55 \frac{(n-2)}{2}$ n = 2,4,6,8...	$25 + 55 \frac{(n-2)}{2}$ n = 2,4,6,8...	$25 + 55 \frac{(n-2)}{2}$ n = 2,4,6,8...
	1	15	25	25
D-F5 □ D-J5 □ D-F5 □ W D-J59W D-F5BAL D-F59F	2 (different side or same side)	15	25	25
	n (same side)	$15 + 55 \frac{(n-2)}{2}$ n = 2,4,6,8...	$25 + 55 \frac{(n-2)}{2}$ n = 2,4,6,8...	$25 + 55 \frac{(n-2)}{2}$ n = 2,4,6,8...
	1	10	25	25
	2 (different side or same side)	15	25	30
D-F5NTL D-F5LF	n (same side)	$15 + 55 \frac{(n-2)}{2}$ n = 2,4,6,8...	$25 + 55 \frac{(n-2)}{2}$ n = 2,4,6,8...	$30 + 55 \frac{(n-2)}{2}$ n = 2,4,6,8...
	1	10	25	30
	2 (different side or same side) 1	15		
D-Z7 □ D-Z80 D-Y59 □ D-Y7P D-Y7 □ W	n side	$15 + 40 \frac{(n-2)}{2}$ n = 2,4,6,8...		
	2 (different side or same side) 1	10		
D-Y69 □ D-Y7PV D-Y7 □ WV	n	$10 + 30 \frac{(n-2)}{2}$ n = 2,4,6,8...		
	2 (different side or same side) 1	20		
D-Y7BAL	n	$20 + 45 \frac{(n-2)}{2}$ n = 2,4,6,8...		
	2 (different side or same side) 1	15	20	
D-P5DWL	n	$15 + 65 \frac{(n-2)}{2}$ n = 2,4,6,8...	$20 + 65 \frac{(n-2)}{2}$ n = 2,4,6,8...	